

PEARL MX-T FRAME CARRIER

ASSEMBLY MANUAL

Congratulations on your purchase! To get optimum performance of your MX-T FRAME CARRIER, please read this Instruction Manual before playing.

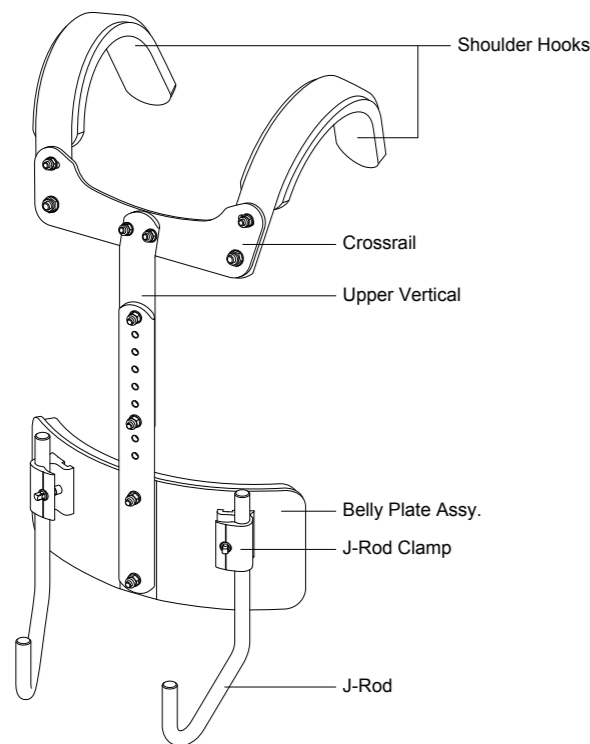

Assembling the Carrier

Locate the (6) M6x25mm and (2) M8x25mm Carriage Bolts with Washers and Hex Nuts. Assemble the MX Carrier per Fig.1 making sure the Carriage Bolts are in the appropriate holes and are facing in the direction shown.

For the MXB-1 Bass Carrier, assemble the J-Bolts as shown in Fig.2.

Tighten the nuts securely with the provided wrench (don't over tighten).

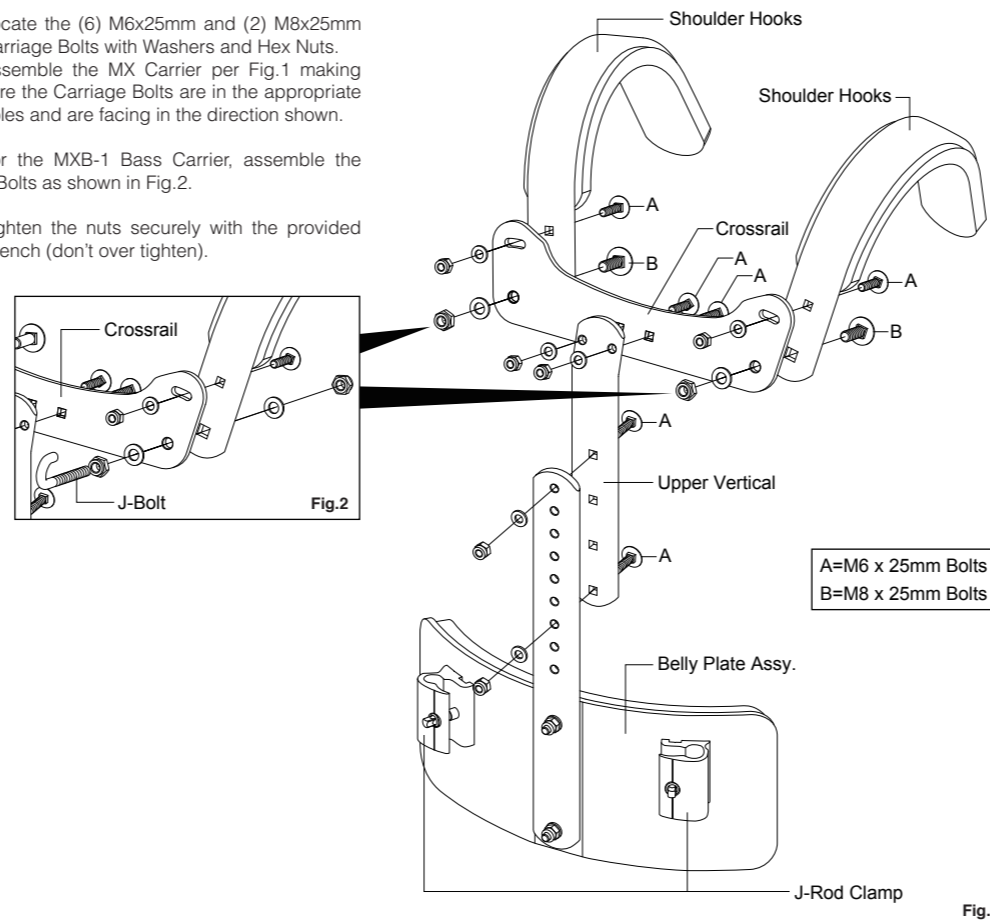

Assembling the Snare Attachment

When using the Snare Attachment on FFX or CMSX Snare Drums, remove the Clip Bracket Tongue before attaching. When using the Snare Attachment on CMS Snare Drums, remove the two Claws before attaching.

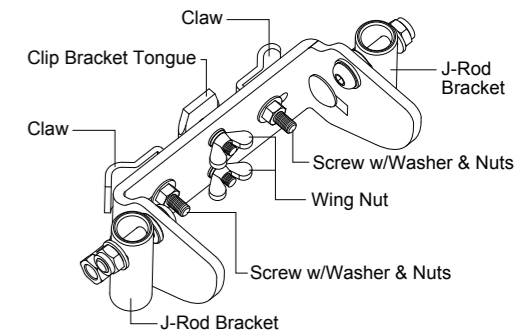

Installing on FFX, CMSX Snare Drums

Remove the two Claws from the Snare Attachment and position them on the snare drum tension posts as shown in Fig. 4. Hold them in place and fit the bolts into the appropriate holes in the Snare Attachment. Tighten the nuts securely with the provided wrench (don't over tighten).

Note: MXSP-1 Pipe Drum Carriers come with a CXSA-1 attachment (not shown) which uses the same procedure for installation.

Installing on CMS Snare Drums

Make sure the two Wing Nuts are tight on the Clip Bracket Tongue and insert the Clip Bracket Tongue into the Clip Bracket on the Snare Drum as shown in Fig. 5.

The Snare Drum can be angled by loosening the Wing Nuts and rotating the attachment along the curved slot. Tighten the Wing Nuts after the angle is set.

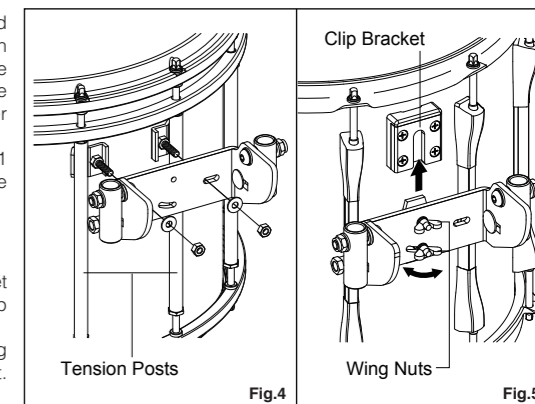

Assembling the Back Bar for Tenor Drums

Locate the (4) M8x20mm Bolts with Washers and Hex Nuts. Assemble the Swivel Arms per Fig. 6 making sure the Carriage Bolts are in the appropriate holes and are facing in the direction shown. Tighten the nuts securely with the provided wrench (don't over tighten).

Locate the (4) M8x30mm Bolts with Washers and Hex Nuts and position the Bolts as shown in Fig. 6. Attach the toms with the Bolts then tighten the Nuts securely with the provided wrench (don't over tighten). Note that the washers go inside the toms against the Hex Nuts.

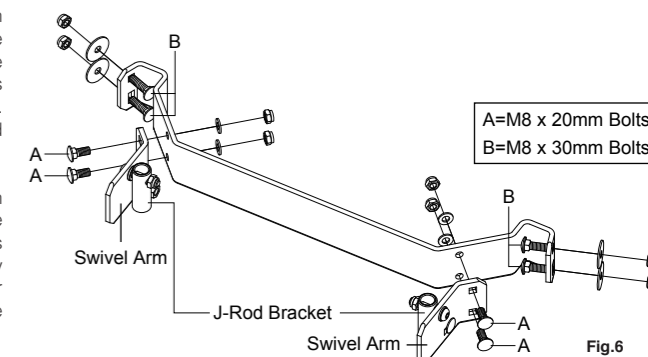

CONTENTS

	MXS-1	MXSP-1	MXT3-1	MXT4-1	MXB-1
M8 x 20mm Bolt w/Washer & Nut (x4)	---	---	●	●	---
M8 x 25mm Bolt w/Washer & Nut (x2)	●	●	●	●	---
M8 x 30mm Bolt w/Washer & Nut (x4)	---	---	●	●	---
M6 x 25mm Bolt w/Washer & Nut (x6)	●	●	●	●	●
J-Bolt w/Washers & Nuts (x2)	---	---	---	---	●
J-Rod, Short (AL-40, x2)	●	---	---	---	---
J-Rod, Extra Short (AL-72, x2)	---	●	---	---	---
J-Rod, Long (AL-65, x2)	---	---	●	●	---
Stabilizer Rod (AL-70, x2)	---	---	---	---	●
Back Bar	---	---	● (MX3BB-1)	● (MX4BB-1)	---
Snare Attachment	● (MXSA-1)	● (CXSA-1)	---	---	---

For MXS-1, MXSP-1, MXT3-1, and MXT4-1 Carriers, assemble the J-Rods to the J-Rod Clamps per Fig. 3 and tighten the Key Bolts securely using a drum key (don't over tighten). For MXB-1 Carriers, assemble the Stabilizer Rods to the J-Rod Clamps per Fig. 3 and tighten the Key Bolts securely (don't over tighten).

The Shoulder Hooks on all MX Carriers are adjustable laterally for a customized fit. To adjust, loosen the nuts that attach the Shoulder Hooks to the Crossrail and adjust the angle of the Shoulder Hooks to your preference and retighten the nuts.

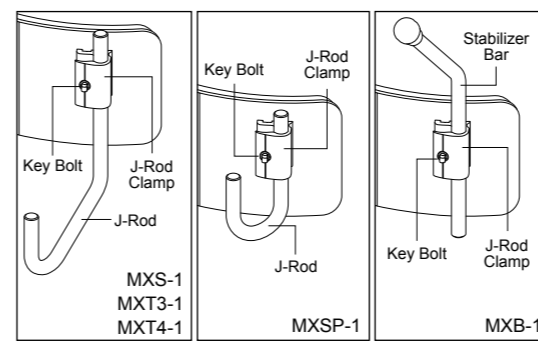

Fig.3



<http://www.pearldrums.com>
Products and specifications are subject to change without notice.

Printed in Taiwan
-1002-