

Base Section Assembly (Fig.1)

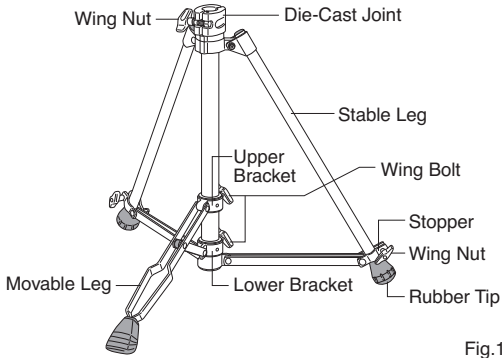

Fig.1

a) Using on Flat Surface (As shown in Fig. 2)

1. Loosen the Wing Nuts on the Stoppers of the Stable Legs.
2. Slide the Stoppers to the end of the Legs to the Rubber Tip, and tighten the Wing Nuts.
3. Loosen the Wing Bolt on the Upper Bracket of the Movable Leg.
4. Slide the Upper Bracket up and adjust the position until the base stands straight up, and tighten the Wing Bolt.

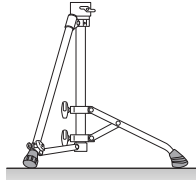

Fig.2

b) Using on Uneven Surface (As shown in Fig. 3)

1. Loosen the Wing Nuts on the Stoppers of the Stable Legs.
2. Slide the Stoppers to the end of the Legs to the Rubber Tip, and tighten the Wing Nuts.
3. Loosen the Wing Bolts on the Upper and Lower Bracket of the Movable Leg.
4. Slide the Upper Bracket to the top of the pipe, and tighten the Wing Bolt.
5. Slide the Lower Bracket and adjust the position until the base stands straight up, and tighten the Wing Bolt.

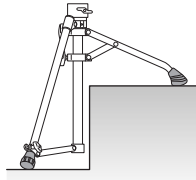

Fig.3

Note

If the distance between the Rubber Tip of the Movable Leg and the center of the pipe becomes shorter than 30 cm, slide both the Upper and Lower Bracket and adjust their positions. Make sure to adjust the position so that the base stands straight up. (Fig. 4)

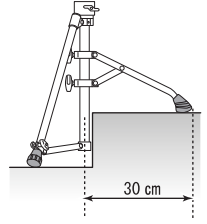

Fig.4

Top Section Assembly (Fig.5)

1. Loosen the Wing Nut of the Die-Cast Joint of the Base.
2. Insert the top section as shown, and tighten the Wing Nut and the Key Bolt on the Stop Lock.

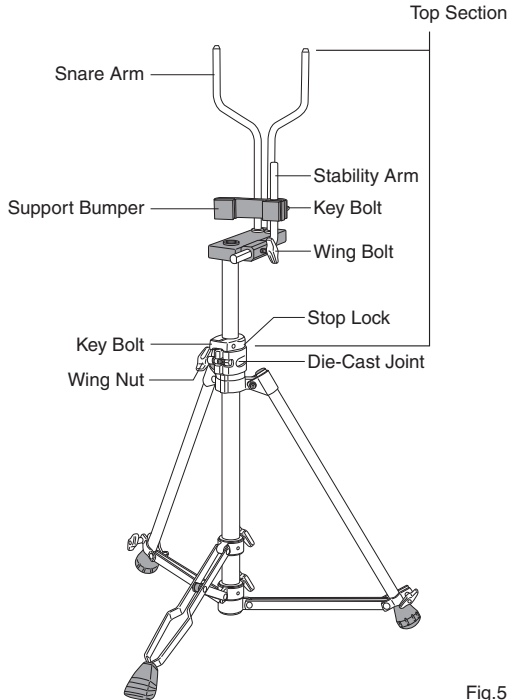

Fig.5

Note

For height adjustment, loosen the Wing Bolt on the Die-Cast Joint and the Key Bolt on the Stop Lock, and slide the Top Section. Tighten the Wing Bolt on the Die-Cast Joint and the Key Bolt on the Stop Lock when desired height is achieved. Do NOT make height adjustment with the Snare Drum mounted on the stand.

Setting the Snare Drum

1. Adjust the position of the Stability Arm so that the Support Bumper is just in front of the Snare Arms as shown. (Fig.6)

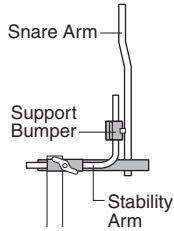

Fig.6

2. Spread the Snare Arms and attach the Snare Drum facing the direction shown in Fig. 7-B.
3. Loosen the Key Bolt on the Support Bumper and adjust its position up or down so that it is touching the bottom hoop of the snare drum. (Fig.7-A, 7-B)

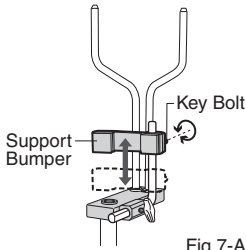

Fig.7-A

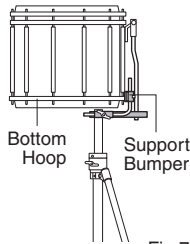

Fig.7-B

4. Press the Support Bumper against the bottom hoop and tighten the Wing Bolt. (Fig.8)

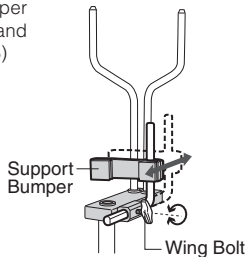

Fig.8

Note

- This stand is designed to be used with snare drums with CXSA-1 or MXSA-1 attachment. Snare drums other than these could result in unstable settings and should not be used.
- Do not overtighten the Key Bolt on the Support Bumper. The Support Bumper will deform and would become stuck on the Stability Arm.

CAUTION

- Do not use on unstable or sloped surfaces, as it could cause the stand to fall, resulting in damage and/or injury.
- Do not make adjustments on the Base Section with the Top Section inserted.
- Do not move the stand with the Snare Drum mounted on the stand.
- Before use, check all Stop Locks to assure they are properly positioned and secured.
- Do not mount the Snare Drum without the Support Bumper. The Snare Drum could become unstable and could cause damage and/or injury.
- Periodically check all Wing Nuts, Wing Bolts and the nuts under the Snare Arm to assure they are tightened securely.
- When making adjustments, support and control the parts being adjusted to prevent them from falling or pinching fingers that may be in the way.
- When folding the legs, be careful not to pinch your fingers between the leg and the stand.
- When handling tubular hardware, do not put your fingers into the tubes top prevent injury to your fingers.

Pearl[®]

<http://www.pearldrums.com>

Products and specifications are subject to change without notice.

Printed in China

-1406-