

# PEARL SNARE STAND S-150S

## Instruction Manual

Congratulations on your purchase!  
To get optimum performance of your S-150S Snare Stand, please read this Instruction Manual before playing.

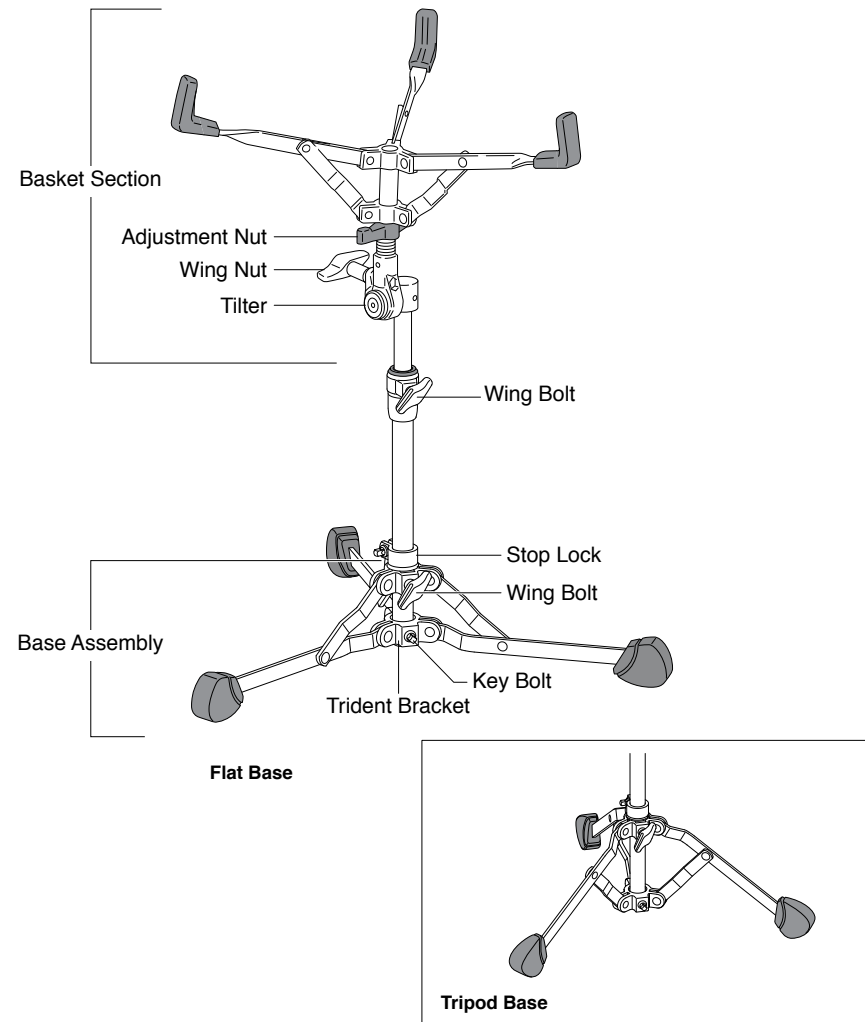

### Converting the Base from Flat Base to Tripod Base

The S-150S Snare Stand come pre-packed from the factory in a Flat Base, and can be converted to a regular Tripod Base. To convert, loosen the Wing Bolt and the Key bolt using a tuning Key of the base, then, slide the legs off from the Base Pipe (Fig.1).

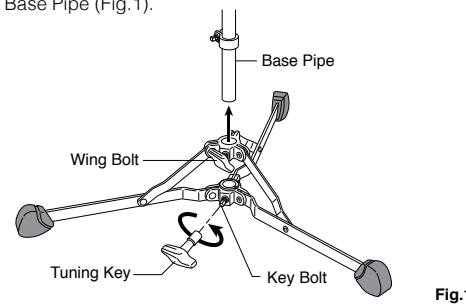

**Note**

- Make sure to remove the snare drum from the stand before converting the stand.
- Support the Base Pipe with one hand to prevent the stand from falling.

Turn the Base Assembly over from Flat Base to Tripod Base, and change the Wing Bolt and the Key Bolt so that the Key Bolt is always at the bottom (Fig.2).

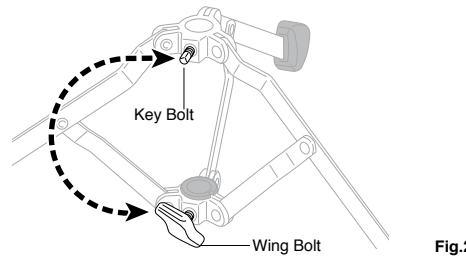

Spread the legs and insert the Base Pipe. Make sure that the bottom of the pipe and the Trident Bracket are set flush, (Fig.8) and tighten the Wing Bolt and the Key Bolt using a tuning Key (Fig.3). Loosen the Key Bolt of the Stop Lock using a Tuning Key and adjust the position of the Stop Lock. Make sure that the Stop Lock is set against the Base and tighten the Key Bolt to secure (Fig.9).

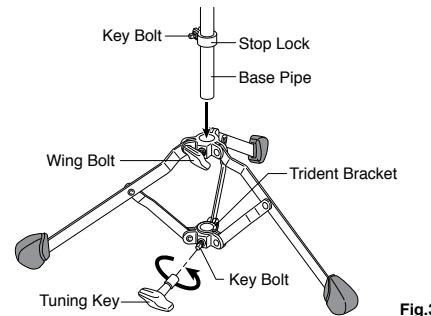

### Converting the Base from Tripod Base to Flat Base

Follow the instruction below to convert the Tripod Base to a Flat Base. Loosen the Wing Bolt and the Key bolt using a tuning Key of the base, then, slide the legs off from the Base Pipe (Fig.4).

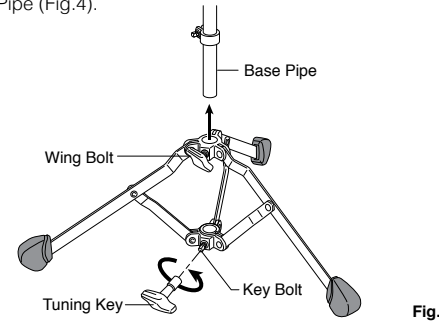

**Note**

- Make sure to remove the snare drum from the stand before converting the stand.
- Support the Base Pipe with one hand to prevent the stand from falling.

Turn the Base Assembly over from Tripod Base to Flat Base, and change the Wing Bolt and the Key Bolt so that the Key Bolt is always at the bottom (Fig.5).

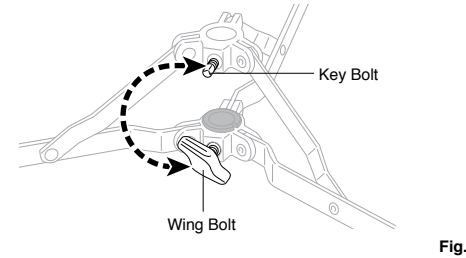

Spread the legs and insert the Base Pipe. Make sure that the bottom of the pipe and the Trident Bracket are set flush, (Fig.7) and tighten the Wing Bolt and the Key Bolt using a tuning Key (Fig.6). Loosen the Key Bolt of the Stop Lock using a Tuning Key and adjust the position of the Stop Lock. Make sure that the Stop Lock is set against the Base and tighten the Key Bolt to secure (Fig.9).

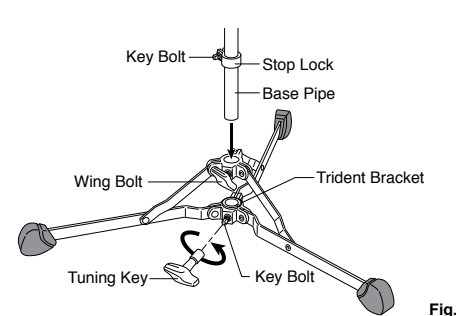

### CAUTION

Make sure that the bottom of the pipe and the bottom of the Trident Bracket are set flush, and that the Key Bolt is at the bottom, with both the Flat Base and the Tripod Base (Fig.7,8).

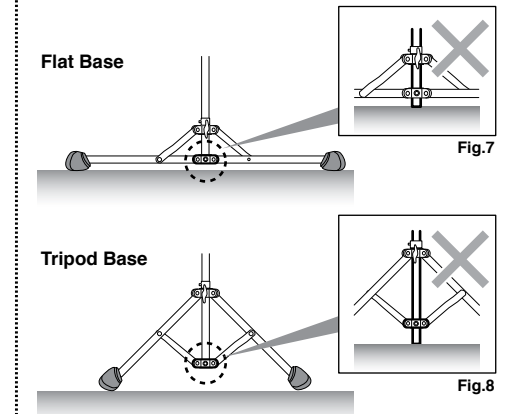

Make sure that the Stop Lock is set against the Base (Fig.9).

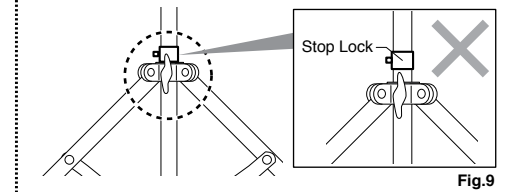

### CAUTION

- When making any adjustment, use one hand to support and make the adjustment while using your other hand to control the tension of the wing nut or wing bolt to prevent the stand from falling and pinching fingers that may be in the way.
- When folding the tripod legs, be careful not to pinch your fingers between the legs and the stand.
- When handling tubular hardware do not put your fingers into the tubes to prevent injury to your fingers.
- Do not tighten the bolts without the pipes inserted to prevent damage to the stand.
- Test the stability of the stand before using.

**Pearl**

<http://www.pearldrums.com>  
Products and specifications are subject to change without notice.  
Printed in China  
-1801-