

*Pearl*<sup>®</sup>

2022

GENERAL CATALOG





## INSPIRATION AWAITS!

For over 75 years, Pearl's sound sculpting drum set options have given countless drummers their defining voice. Our lineup of premium percussion instruments has a fit for practically any playing style and budget. Our comprehensive Warranty promise lets you play with unparalleled confidence.

No matter where the drumming road takes you, Pearl has you covered - so explore, discover, and *prepare to be inspired.*



### MASTERWORKS

A custom made heirloom instrument tailored to your exacting specifications.

**SHELL RECIPE:** Choice/Combination of Birch, Maple, Gum, and/or Mahogany.

**SOUND:** Your dreams. It literally sounds like the drum set of your dreams.

p. 3 - 11



### REFERENCE

Made with premium Masterworks materials and individually engineered for articulate power and projection.

**SHELL RECIPE:** Reference Recipe Birch, Maple, and Mahogany hybrid.

**SOUND:** Built to fill arenas. Enhanced projection with cutting highs and powerful lows.

p. 12 - 13



### REFERENCE PURE

Reference Recipe shell engineering in a lighter format for increased body and sustain.

**SHELL RECIPE:** EvenPly Birch, Maple, and Mahogany hybrid.

**SOUND:** Expressive, open tonality with responsive bottom-end boost.

p. 14 - 15



### MASTERS MAPLE RESERVE

The vintage flair of the original Masters sound for a refined playing experience.

**SHELL RECIPE:** 4-ply Maple w/ 4-ply Reinforcement Rings.

**SOUND:** Balance of powerful midrange and smooth resonant attack.

p. 16 - 17



### MASTERS MAPLE/GUM

Optimized for the recording studio. Vital tone derived from the Masterworks: Studio shell recipe.

**SHELL RECIPE:** EvenPly-Six Maple (4-ply outer) and Gum (2-ply inner).

**SOUND:** Explosive midrange tonality with full low-end and precise decay.

p. 18 - 19



### MASTERS MAPLE COMPLETE

Professional gear for independent touring. A sonic powerhouse with inspired custom appointments.

**SHELL RECIPE:** EvenPly-Six, 5.4mm North American Maple.

**SOUND:** Booming projection with equalized Low/Mid/High frequency mix.

p. 20 - 21



### SESSION STUDIO SELECT

Radically unique from Stage to Studio. Blends pre-EQ'd warmth and articulate punch.

**SHELL RECIPE:** EvenPly-Six Birch (4-ply outer), African Mahogany (2-ply inner).

**SOUND:** Deep, rich bass frequencies. Top-end tonal spike.

p. 22 - 23



### PRESIDENT SERIES DELUXE

The darkly, dry "MIJ" sound with classically controlled tonality.

**SHELL RECIPE:** 6-ply, 7.5mm Lauan.

**SOUND:** A slick locomotive of subdued, vintage punch with singular low-range overtone.

p. 24 - 25



### CRYSTAL BEAT

The original seamless Acrylic drum shell creates a striking visual and sonic showcase.

**SHELL RECIPE:** 7mm Seamless Molded Acrylic.

**SOUND:** Loud and immediate, delivers pummeling straight tone and yielding feel.

p. 26 - 27



### DECADE MAPLE

An upscale playing experience for the rising drummer, with prime lacquered shells and pro level elements.

**SHELL RECIPE:** EvenPly-Six, 5.4mm Maple.

**SOUND:** Full Maple tone with lively midrange and smooth sustain.

p. 28 - 29



### EXPORT / EXPORT LACQUER

The Best Selling Drum Set of All Time gives the student drummer a strong beginning.

**SHELL RECIPE:** 6-Ply 7.5mm Poplar/Asian Mahogany Blend

**SOUND:** Crisp attack with dark, formidable bottom-end vibrance.

p. 30 - 31



### MIDTOWN

An ultra portable shell pack for full sized play and powerful grooves in a small footprint.

**SHELL RECIPE:** 6-ply 7.5mm Poplar.

**SOUND:** Tight, responsive tonal bite with enough bottom to fill the pocket.

p. 32



### ROADSHOW

A drum set package complete with everything needed to kickstart your rhythmic journey.

**SHELL RECIPE:** 9-ply 7mm Poplar.

**SOUND:** Piercing, open cut with full sub-bass rumble.

p. 33

## 2022 GENERAL CATALOG

#### DRUM SETS

- 3-11 Masterworks
- 12-13 Reference
- 14-15 Reference Pure
- 16-17 Masters Maple Reserve
- 18-19 Masters Maple/Gum
- 20-21 Masters Maple Complete
- 22-23 Session Studio Select
- 24-25 President Series Deluxe
- 26-27 Crystal Beat
- 28-29 Decade Maple
- 30-31 Export / Export Lacquer
- 32 Midtown
- 32 Rocket Toms
- 32 Compact Traveler
- 33 Roadshow / Jr.

#### SNARE DRUMS

- 34-36 Series Component
- 37 Free Floating
- 38 SensiTone Heritage Alloy
- 39-41 Signature
- 42-43 Hybrid Exotic
- 42 DuoLuxe
- 43 StaveCraft
- 44 Modern Utility
- 45 Utility & Effects
- 46-47 e/MERGE
- 48 MIMIC PRO
- 49 malletSTATION

#### ELECTRONIC SERIES

#### HARDWARE

- 50 Demon Drive
- 51 Demon Chain
- 52-53 Eliminator Redline
- 54-55 Eliminator Solo
- 56 P930 / P932
- 57 P530 / P830
- 58-59 Hi-Hat Stands
- 60 Snare Stands
- 61 Drum Thrones
- 62-63 Cymbal Stands
- 64-65 Racks
- 66 Rack Accessories
- 67 Tom Stands
- 67 Tom Arms

#### PERCUSSION

- 68 Percussion Artists
- 69 Signature Series
- 70-71 Congas & Bongos
- 72-73 Travel (Congas, Bongos, Timbales)
- 73 Timbales
- 73 Cowbells
- 74 Djembes
- 75 Folkloric / Brazilian
- 76-77 Cajons & Accessories
- 78 Handpans
- 79 Tongue Drums
- 80 Rainsticks / Nut Shakers
- 81 Concert Percussion
- 82-83 Hand Percussion
- 84 Percussion Stands
- 85 Bags, & Holders

86-89 Replacement Parts

90-93 Pearl Artists

94-BACK Config. & Color Chart

# MASTERWORKS



*Masterworks*

## IMAGINE...

...owning the drum set you've always dreamed of playing. A totally custom-tailored expression of your musical identity, crafted with heirloom precision to elevate your drumming persona.



*“When I heard the Studio Recipe and the Maple/Gum shells, I sort of realized this might be a better tool for my situation, because I have to live in both a studio world and a live environment simultaneously. This Masterworks kit allows me to do that.”*

**NATE MORTON**  
The Voice

NATE MORTON'S "VOICE SEASON 23"  
**MASTERWORKS SONIC SELECT STUDIO RECIPE KIT**  
IN LIME/MINT/ICE SPARKLE LACQUER FINISH W/ CHROME HARDWARE

Handcrafted To Inspire



# MASTERWORKS

Completely Custom, Totally Handmade



## DRUMMING WITHOUT LIMITS

A Masterworks drum set is a timeless expression; custom tailored with heirloom precision to elevate your drumming persona, and fully reflect your musical identity.

## THE MASTERWORKS DIFFERENCE

Selecting the right combination of our finest hand selected shell veneers with the precision engineering of our premium hardware appointments, Masterworks gives you the freedom to customize a sound that is completely your own.

### DRUM SHELL TONE WOODS

Choose one or a combination of our premium shell materials to sculpt the sound of each drum.

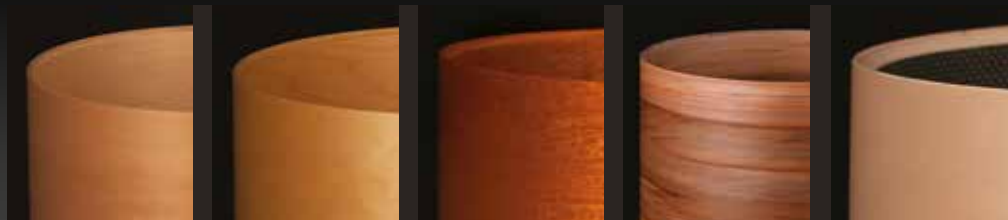

#### MAPLE

Tonally equal in highs, mids, and lows for prime, full bodied attack and sustain.

#### BIRCH

Boosted attack with "Built-in EQ" for articulate and evenly reduced decay.

#### AFRICAN MAHOGANY

Dark, elegant tone with powerful bottom-end emphasis.

#### GUMWOOD

As a core or interior ply, Gum enhances tone in surrounding plies.

#### CUSTOM INTERIOR

Choose any of Pearl's Artisan Exotic veneers, carbon fiber, or hand applied fiberglass for boutique tones and visuals.

### SHELL SIZE AND THICKNESS

For precise tonal character, sustain, and projection.

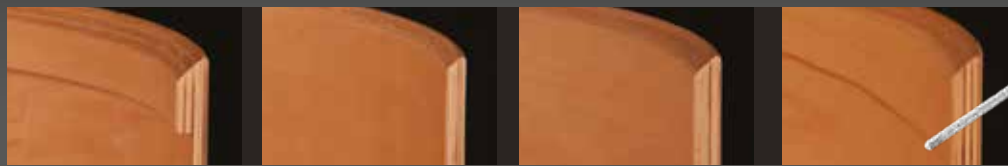

**THIN** (4-ply, 5mm w/ 4-ply Reinforcement Rings) Increased sustain and low-end.

**MEDIUM** (EvenPly-Six, 5.4mm) Expanded tonal purity and resonant punch.

**STANDARD** (6-ply, 7.5mm) Full-bodied tonal projection ideal for general purpose.

**THICK** (8-ply, 10mm and 10-ply, 12.5mm) Maximum projection and quick decay.

### FINISHES

Craft an inspired visual statement with drums hand finished and configured to your specifications.

#### LUXURY

Includes a choice of High Gloss, Satin Stain, and Sparkle Lacquer.

#### CUSTOM

Includes Pinstriping, Banding, Artisan II Custom Graphics.

#### ARTISAN

Choose from a selection of Exotic veneers (below) or hand applied Carbonply.



CAMEROON BLACK LIMBA

FLAME MAPLE

AFRICAN ZEBRA WOOD

TAMO ASH

WATERFALL BUBINGA



EUCALYPTUS

BURL MAHOGANY

CARBONPLY

SYCAMORE w/ EBONY INLAY\*

\*Ebony Inlay available on all Masterworks finishes



**MASTERWORKS SONIC-SELECT STADIUM RECIPE SHELLS WITH ARTISAN FLAME MAPLE AMBER EXOTIC GLOSS FINISH AND CHROME HARDWARE**

### BEARING EDGE

Masterworks offers a choice of five sonically tested edges - configurable by drum, application, and shell side.



**STANDARD 45°**  
Provides the perfect blend of attack and warmth.

**OUTER 60°**  
Pulls brighter overtones and increases punch.

**INNER 45°** Edge apex focused to inner shell plies for controlled sustain.

**ROUNDED 45°** Increased head-to-shell contact boosts mids and highs.

**FULLY ROUNDED**  
Boosts mid-to-low range response and reduces decay.

**HARDWARE FINISH, LUG, AND HOOP OPTIONS**

A choice of five plating options comes standard on your selection of our precision tuning lugs, hoops, and drum hardware.

**FINISHES**



**CHROME**  
(Shown w/  
CL100 Lug)



**NICKEL**  
(Shown w/  
STL100 Lug)



**GOLD**  
(Shown w/  
STL150 Lug)



**BLACK CHROME**  
(Shown w/  
BRL100 Lug)



**BLACK NICKEL**  
(Shown w/  
STL150 Lug)

**HOOPS**



**MASTERCAST DIE-CAST**



**2.3MM SUPERHOOP II**



**FATTONE**

**LUGS**

- Bridge (CL100)
- Swivel Tube (STL150)
- Single Swivel (STL100)
- Swivel Arch (BRL100)



**WHAT'S INSIDE**

Discover the elements of superior drum tone.



**DIFFERENCE - The Ultimate in Strength, Resonance, and Tone.**

Using the world's first high temperature hydraulic curing system, the SST method was developed to craft a multi-ply, bonded drum shell with single-ply resonance and strength.

All shells are formed in a bonded combination of cross-laminated 2-ply veneer panels; precision milled with overlapping scarf joint seams and cured with our exclusive AcoustiGlue at 1000 PSI of hydraulic pressure.

# MASTERWORKS

*Sonic-Select Shell Recipe*



**CHOOSE YOUR ARENA. CREATE YOUR DREAM. DEFINE YOUR SOUND.**  
Our Sonic-Select Shell Recipes narrow the nearly endless scope of Masterworks choices down to five sonically proven shell and hardware combinations.

## STUDIO



**MASTERWORKS SONIC-SELECT STUDIO** RECIPE SHELLS WITH ARTISAN BLACK LIMBA-BURST EXOTIC GLOSS FINISH AND CHROME HARDWARE

### STUDIO

- SHELL EvenPly-Six (5.4mm), 4-ply Maple Outer with 2-ply Gumwood Inner
- BEARING EDGE Outer 60° Gives increased power and bite to a thinner hybrid shell
- HOOPS MasterCast Hoops
- LUGS CL Bridge Lug  
CL100 (Toms)  
CL250 (Bass Drum)
- SPURS SP300 w/ Retractable Spike
- FT BRACKETS LB200

### A POWERFUL SONIC FOUNDATION TUNED FOR THE RECORDING ENVIRONMENT.

This commanding shell/edge combination of hard exterior and milder tone woods yields explosive midrange projection and extended low end punch.



**SHELL**  
Thin, resonant combination of a hard exterior with milder tonewood for explosive low-range warmth.



**BEARING EDGE**  
Outer 60° Gives increased power and bite to a thinner hybrid shell.



**HOOPS**  
MasterCast Hoops. Escalates weight for tonal body. Increases volume in high velocity play.



**LUGS**  
CL Bridge Lug. A classic look with minimal shell contact for precise vibration control.



## CUSTOMIZED TO FIT YOUR CREATIVE VISION

Like a blank canvas for your drumming ideal, modify any Sonic-Select Shell Recipe shell or hardware option to give it your own spin or use our exclusive Artisan II process to embed your choice of high definition graphics directly onto the outer shell.

### STUDIO

Explosive tonal clarity and articulation for recording.  
pg. 6

### URBAN

A thin, powerful blend for the precise metropolitan drummer.  
pg. 7

### STADIUM

Pearl's thick CZX Maple shell for high-volume power.  
pg. 8 - 9

### HERITAGE

Classic drum feel with enhanced lows and fat top-end slap.  
pg. 8

### MODERN DRY

Quick, top-heavy articulation with controlled low-end.  
pg. 9

## URBAN



MASTERWORKS SONIC-SELECT URBAN RECIPE SHELLS WITH ARTISAN BLACK LIMBA BLUEBURST EXOTIC GLOSS FINISH AND BLACK CHROME HARDWARE

### URBAN

SHELL	EvenPly-Six (5.4mm Toms/Bass) 2-Birch/2-Gumwood/2-Birch with 4-ply Maple Re-Rings 8-ply Snare Drums 2 Birch/4 Gumwood/2 Birch
BEARING EDGE	Rounded 45° on Toms Fully Rounded edge on bass drums Standard 45° on snare drums
HOOPS	2.3mm SuperHoop II*
LUGS	STL Swivel Tube Lugs* STL150* (Toms) STL300* (Bass Drum)
SPURS	SP300 w/ Retractable Spike
FT BRACKETS	LB200

\*Recommended

### A FRESH SONIC DRUM BLEND FOR THE METROPOLITAN PLAYER.

From sold out tours to sanctuary halls, the tonal dichotomy of three proven hardwoods projects with a defiant top end and fills the bass frequencies with thunderous, shaking lows.



**SHELL**  
Dense, thin shell hybrid for precise punch and quick, even decay.



**HOOPS**  
2.3mm SuperHoop II Hoops - Made for heavy play without limiting tuning range performance.



**BEARING EDGE**  
Rounded 45° on Toms (Fully Rounded edge on bass drums, Standard 45° on snare drums).



**LUGS**  
A medium-weight lug with pivoting tension casing for increased projection and reduced overtone. STL150 / 300

# MASTERWORKS

Sonic-Select Shell Recipe



**SONIC-SELECT**  
SHELL RECIPES

**MASTERWORKS:**  
COMPLETELY CUSTOM,  
TOTALLY YOU



### STADIUM

**SHELL** 10-ply Maple BD, 10-ply Maple FT, 8-ply Maple Toms and Snares  
**BEARING EDGE** Outer 60° For increased power and controlled overtone  
**HOOPS** 2.3mm SuperHoop II\*  
**LUGS** Swivel Bridge Lugs to maintain attack and tuning integrity. BRL100\* (Toms) BRL300\* (BD)  
**SPURS** SP300 w/ Retractable Spike  
**FT BRACKETS** LB200

\*Recommended

### THE CZX SOLUTION FOR HIGH VOLUME, RHYTHMIC COMMAND.

Pearl's legendary high density CZX Maple shell is reborn! Our classic 10-ply / 8-ply shell combination delivers penetrating volume, articulate midrange attack, and focused low end.



### SHELL

A thick shell for dominating volume and articulate attack.



### BEARING EDGE

Outer 60° Increases brightness and power with controlled overtone.



### HOOPS

2.3mm SuperHoop II Hoops - Made to withstand heavy play while allowing the shell to breathe.



### LUGS

Heavier weight increases attack and assures the ultimate in tuning integrity.

## HERITAGE

### TIMELESS, ORGANIC TONE WITH SMOOTH LOW-END GROWL

The Heritage Recipe's robust blend of reinforced Maple/Mahogany delivers solid midrange punch with exceptional sustain and thunderous sub bass frequencies.

### HERITAGE

**SHELL** 4-ply Maple (2-ply outer) Mahogany (2-ply inner) w/ 4-ply Maple Re-Rings  
**BEARING EDGE** Standard 45° Low contact edge for added projection and resonance  
**HOOPS** 1.6mm FatTone\*  
**LUGS** STL100\* (Toms) STL200\* (Bass Drum)  
**SPURS** SP300 w/ Retractable Spike  
**FT BRACKETS** LB200

\*Recommended



**MASTERWORKS SONIC-SELECT HERITAGE**  
RECIPE SHELLS WITH ARTISAN TAMO RUBY GLOSS LACQUER WITH NATURAL/BLACK RALLY STRIPES, AND BLACK NICKEL HARDWARE



### SHELL

A traditional blend of midrange punch and boosted low-end.



### BEARING EDGE

Standard 45° - Precise, low-contact edge for added projection and resonance.



### HARDWARE

FatTone Hoops - The light, rigid design of its exclusive hemmed edge increases resonance and tuning stability.



### LUGS

Our lightest and most efficient tuning lug reduces hardware contact and weight on the shell.

# STADIUM



**MASTERWORKS SONIC-SELECT STADIUM**  
 RECIPE SHELLS WITH ARCTIC GLOSS WHITE LACQUER OVER  
 CARBONPLY INNER/OUTER AND BLACK CHROME HARDWARE

19" CUSTOM AUTO RIM COURTESY OF AUTO CENTER INC., NASHVILLE, TN

# MODERN DRY

## DARKLY ORGANIC PUNCH FOR DRIVING, ORGANIC BEAT MAKING.

The Modern Dry Recipe blends three sonically unique tone woods for dark, controlled tone, and pillowy response. Its unique blend of shell and hardware elements adds bottom end focus and throaty punch.

### MODERN DRY

SHELL	2-ply Maple outer/2-ply Gumwood inner with 4 ply Mahogany Re-Rings
BEARING EDGE	Inner 45°
HOOPS	MasterCast Hoops
LUGS	Single Swivel Lugs
SPURS	STL100 (Toms) STL200 (BD)
FT BRACKETS	SP300 w/ Retractable Spike LB200

**MASTERWORKS SONIC-SELECT MODERN DRY**  
 RECIPE KIT IN SATIN AZURE FADE LACQUER FINISH  
 OVER ARTISAN ZEBRAWOOD VENEER  
 WITH GOLD-PLATED HARDWARE



**SHELL**  
 A unique blend of yielding tone woods and rigid exterior for added bottom-end focus.



**BEARING EDGE**  
 Inner 45° - Its inner shell apex contacts the head inside the shoulder for focused control in low tunings.



**HOOPS**  
 MasterCast Hoops - Gives each drum added weight for increased volume and controlled sustain.



**LUGS**  
 Single Swivel Lugs  
 Our lightest and most efficient tuning lug for reduced shell contact. STL100 / 200

# REFERENCE

*Sonically Select Drum Performance*

## DELIVERING OPTIMUM SOUND AND PROJECTION FOR THE POWER PLAYER

Utilizing the nearly limitless selection of materials and options from our Masterworks Custom Shop, each Reference tom, snare, and bass drum is individually-optimized with its own shell, hardware, and edge "Recipe" to best capture its intended voice.

Just as single notes combine to make a piano, the total Reference kit's singular, unified voice perfectly captures every nuance of your unique drumming ideal.



#376 Ultra Blue Fade  
RF943XP/C

Pearl offers Reference Pure in 3 stocking colors and 23 special order colors in different varieties of Lacquer or Premium Wrap finishes - see back cover.



#103 Piano Black



#393 Purple Craze II



#736 Turquoise Pearl

RF904XEP/C

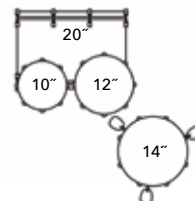

RF924XEP/C

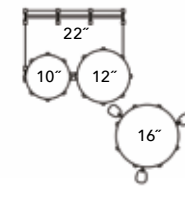

RF943XEP/C  
(Special Order Only)

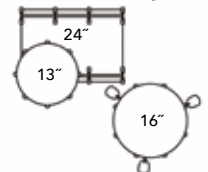



#839 Red Burst Triband  
RF923XSP/C

## REFERENCE

**SHELL** Maple, Birch & African Mahogany  
**SNARE** 20 Ply Matching 13 x 6.5, 14 x 5 or 14 x 6.5\*  
**FINISH** Super High Gloss Lacquer / Lacquer Sparkles  
**HEADS** Remo Clear Emperor Tom, Powerstroke3 Bass  
**TOM MOUNTS** Aluminum OptiMount Suspension System  
**TOM ARMS** Sold Separately  
**HARDWARE** Chrome (Standard)\*\*  
**HOOPS** MasterCast Die-Cast Hoops  
**LUGS** BRL Bridge Lugs with Swivel Function  
*\*Sold Separately \*\*Nickel, Black Chrome, Black Nickel, and Gold Hardware (Special Order)*



### MASTERCAST HOOP

Enhance the overall weight and volume of each shell and stay true under constant play.

### BRL SWIVEL LUGS

Feature pivoting internal brass tension casings to assure tuning integrity and reduce shell stress.

**SHELLS** Individually engineered for power, tone, and distinction, the total Reference kit perfectly captures every nuance of your unique drumming identity with a singular, prestigious sound.



**SP300 SPUR**  
 Pearl's SP300 bass drum spur features retractable high grip rubber tip and recessed spike for high impact, slip free play.

REFERENCE RECIPE	SHELL TYPE	BEARING EDGE	SONIC OUTPUT
8" and 10" Toms	 <b>Maple(4)/Birch(2)</b> 6-ply (RF 7.5mm / RFP 5.4mm)	Rounded 45°	Cutting projection for high-note pitch
12" Toms	 <b>Maple(6)</b> 6-ply (RF 7.5mm / RFP 5.4mm)	Rounded 45°	Transitional mid-note; blend of warmth and cut
13" Toms	 <b>Maple(4)/Mahogany(2)</b> 6-ply (RF 7.5mm / RFP 5.4 mm)	Rounded 45°	Top-end slap with added low/bottom end
14" and 15" Toms	 <b>Maple(4)/Mahogany(2)</b> 6-ply (RF 7.5mm / RFP 5.4 mm)	Fully Rounded	Bracing low-end with controlled punch
16" Toms	 <b>Maple(2)/Mahogany(4)</b> 6-ply (RF 7.5mm / RFP 5.4mm)	Fully Rounded	Full, rounded sustain and gated attack
14" Floor Toms	 <b>Maple(4)/Mahogany(4)</b> 8-ply (RF 10mm / RFP 7.2mm)	Fully Rounded	Fat, controlled low-end with smooth roll-off
16" and 18" Floor Toms	 <b>Maple(2)/Mahogany(6)</b> 8-ply (RF 10mm / RFP 7.2mm)	Fully Rounded	Fat, controlled low-end with resonant warmth
18" and 20" Bass Drums	 <b>Maple(2)/Mahogany(4)</b> 6-ply (RF 7.5mm / RFP 5.4mm)	Fully Rounded	Quick and Punchy with Powerful low-end
22" and 24" Bass Drums	 <b>Maple(2)/Mahogany(6)</b> 8-ply (RF 10mm / RFP 7.2mm)	Fully Rounded	Booming bass tone with articulate punch

# REFERENCE PURE

*Unrestricted Tonal Response*

**THE EVENPLY DIFFERENCE** lies in thinner shell layers. Using the same hybrid wood composition as the Reference Recipe with thinner plies gives the Reference Pure shell a lean profile with increased strength. Combining the ultra thin EvenPly shell with more efficient shell hardware reduces overall drum weight by 30% for increased resonance, improved bottom end, and a more nuanced near field playing experience.



#124 Matte Black  
RFP943XEP/C

## REFERENCE PURE

SHELL	Low Mass EvenPly Maple, Birch & African Mahogany
SNARE	EvenPly-Six Matching 13 x 6.5, 14 x 5, 14 x 6.5*
FINISH	Super High Gloss Lacquer / Lacquer Sparkles
HEADS	Remo Clear Emperor Tom, Powerstroke3 Bass
TOM MOUNTS	Aluminum OptiMount Suspension System
TOM ARMS	Sold Separately
HARDWARE	Chrome (Standard)**
HOOPS	Low Mass FatTone Hoops
LUGS	Low Mass STL Swivel Tube Lugs

\*Sold Separately \*\*Nickel, Black Chrome, Black Nickel, and Gold Hardware (Special Order)

Nickel (N), Gold (G) Black Chrome (B) Or Black Nickel (BN)  
Plated Hardware Available By Special Order For A Premium Charge



**SHELLS**  
Boasting the same shell construction that made Reference drums a professional standard, Reference Pure's uninhibited, shell-focused tonality excels in any playing environment.

RFP904XEP/C

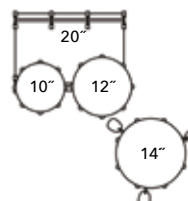

RFP924XEP/C

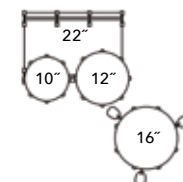

RFP943XEP/C  
(Special Order Only)

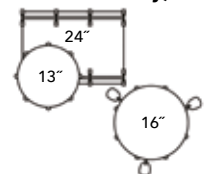



#843 Osiria Rose Stripe  
RFP904XEP/C



#844 SATIN ROSE GOLD  
RFP904XEP/C

Pearl offers Reference Pure in 3 stocking colors and 23 special order colors in different varieties of Lacquer or Premium Wrap finishes - see back cover.



#124 Matte Black

#843 Osiria Rose Stripe

#844 Satin Rose Gold



#### 1.6MM FATTONE HOOPS

Exclusive hemmed/welded edge (U.S. Pat. #8367917) gives increased strength to low mass design.



#### STL SWIVEL TUBE LUGS

Allow for increased resonance, minimal shell contact, and precisely aligned, no bind tuning.

#### OPTIMOUNT

Aluminum Tom Mounts suspend the drum evenly across four tension points to allow resistance-free resonance in play.



#### AIR SUSPENSION RUBBER TIP

(U.S. Patent #5881981) Isolates the tom from the floor, preventing tonal choke and increasing resonance.



#### GOLDEN RATIO AIR VENT

(U.S. Patent #7485791) is precision placed in the Fibonacci Spiral on toms to increase low-end response.



#### SNARE DRUMS

A thin EvenPly-Six shell with four outer Maple and two inner Birch plies for cut, projection, and smooth, balanced sound. 45° bearing edges provide superbly articulate sensitivity.



#### SR1000

SR1000 Glide-Lock Strainer's locking throw off lever and tension knob assures slip-free performance. (U.S. Patent #7220905, #7301087, #7365256)

# MASTERS MAPLE RESERVE

A Classic Formula  
for Sonic Greatness

## THE MASTERS LEGACY

Derived from Pearl's original Masters shell recipe, Masters Maple Reserve Drums deliver a sophisticated, balanced tonal combination of powerful midrange and sustained resonant shimmer. Projecting vintage flair, centered sonic character, and rich, tonal balance, Masters Maple Reserve is truly something to be experienced.



\*\*\*Nickel (N), Gold (G) Black Chrome (B) Or Black Nickel (BN)  
Plated Hardware Available By Special Order For A Premium Charge

#839 Red Burst Triband  
MRV943XP/G

*Masters*  
MAPLE RESERVE

## MASTERS MAPLE RESERVE

SHELL	4-ply (5mm) 100% Maple w/ 4-ply Maple Re-Rings
SNARE	Matching 14x5.5 or 14x6.5*
FINISH	Super High Gloss and Matte Lacquer**
HEADS	Coated/Ported Powerstroke3 Bass (Front) Clear Powerstroke3 (Batter)
TOM MOUNTS	Aluminum OptiMount Suspension System
HARDWARE	Chrome***
HOOPS	Low Mass FatTone Hoops
LUGS	CL Bridge Lugs
BD MUFFLER	BDMF (Full Size) *Sold Separately



#824 Satin Charred Oak  
MRV924XEP/BN

## SHELLS

4-ply Maple shell with 4-ply Maple Reinforcement Rings.  
A classic shell fusion delivering rich, sustained lows and controlled sonic punch.



Pearl offers Masters Maple Reserve in 4 stocking colors  
and 22 special order colors in different varieties of Lacquer  
or Premium Wrap finishes - see back cover.



#415 Bronze Oyster



#824 Satin  
Charred Oak



#850 Aqua  
Turquoise Stripe



#839 Red Burst  
Triband







**ALUMINUM OPTIMUM SUSPENSION SYSTEM**

Light and efficient four-point contact design delivers secure tom mounting without penetrating the shell.



**HARDWARE FatTone Hoops**  
- Rigid 1.6mm hemmed/welded edge extends sustain with punchy projection.



**CL BRIDGE LUGS**  
A classic lug with a minimal contact arc for precise vibration control.



**BEARING EDGE**  
Standard 45°



#850 Aqua Turquoise Stripe  
**MRV943XEP/BN**

**MRV904XEP/**

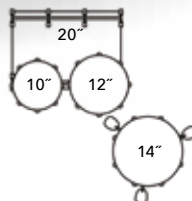

**MRV924XEP/**

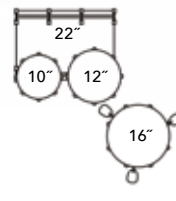

**MRV923XSP/**

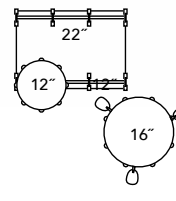

**MRV943XEP/**  
**(Special Order Only)**

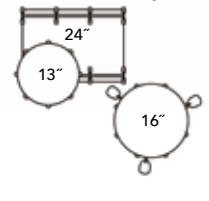

# MASTERS MAPLE/GUM

*The Evolution of  
Premium Studio Tone*

## THE MASTERWORKS STUDIO RECIPE, SIMPLIFIED.

Delivering arguably the greatest drum tones ever recorded, Pearl's fresh take on the legendary Maple/Gum shell recipe reaches new levels in dynamic sonic warmth and explosive low-end response.

Now, Pearl expands Masters Maple/Gum with updated finish and component options; making our first production Masterworks kit a true prize for the owner.



#418 Blue Abalone  
MMG924XSP/C

MMG904XP/C

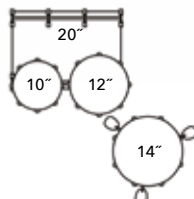

MMG923XSP/C

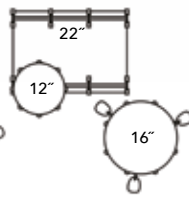

MMG924XSP/C

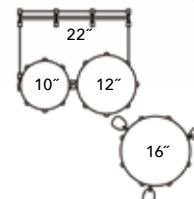

MMG983XP/C  
(Special Order Only)

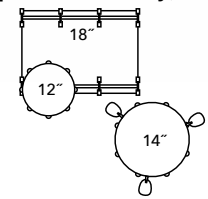

# Masters

MAPLE/GUM



#186 Hand Rubbed  
Natural Maple



#418 Blue  
Abalone



#453 Platinum  
Gold Oyster

Pearl offers Masters Maple/Gum in 3 stocking colors and 23 special order colors in different varieties of Lacquer or Premium Wrap finishes - see back cover

\*Shell Packs: Stock, Components: Special Order.  
Added components in #186 can be special ordered.

## MASTERS MAPLE/GUM

SHELL	EvenPly Six (6-ply, 5.4mm) North American Maple/Gum
FINISH	Hand-Rubbed Natural Wax or Premium USA Wrap
HEADS	Remo Coated Ambassador, Powerstroke3 Bass
TOM MOUNTS	OptiMount Aluminum Suspension System
HARDWARE	Chrome
HOOPS	MasterCast Die-Cast
LUGS	CL Bridge Lugs



#186 Hand Rubbed Natural Maple  
MMG924XSP/C MUS1410FM

**SHELLS**  
EvenPly-Six, 4-ply Maple outer  
with 2-ply Gumwood inside -  
The natural warmth of Maple  
is enhanced by Gumwood's  
dense, controlling character.



**MASTERCAST  
HOOPS**  
Escalates weight  
for tonal body and  
increases volume in  
high velocity play.



**BEARING EDGE**  
Outer 60° - Gives  
increased power  
and bite to a thinner  
hybrid shell.



**CL BRIDGE  
LUGS**  
A classic look  
with minimal shell  
contact for precise  
vibration control.  
CL100 / 250

# MASTERS MAPLE COMPLETE

An All Maple Drum Shell Fit for the Masters Legacy

**UNPARALLELED SOUND. ATTAINABLE PRICE.**

Fully loaded with all the elements that made Pearl's Masters Series a must for the touring drummer, Masters Maple Complete offers a tonally superior percussive statement for the road ready pro.

## MASTERS MAPLE COMPLETE

SHELL	EvenPly Six (6-ply, 5.4mm) 100% Maple
SNARE	Matching 14x5.5 or 14x6.5*
FINISH	Super High Gloss Lacquer or Premium USA Wraps
HEADS	Remo UT Pinstripe Tom, Ported UT Powerstroke3 Bass
TOM MOUNTS	OptiMount Suspension System
HARDWARE	Chrome
HOOPS	SuperHoop II
LUGS	2.3mm Triple Flanged CL Bridge Lugs

\*Sold Separately



### SHELLS

EvenPly-Six (5.4mm) North American Maple - Fuses reduced thickness, cross laminated ply panels for expanded tonal purity and increased resonance.

#836 Red Burst Stripe  
MCT923XSP/C



Six premium finishes are available in four preconfigured shell packs, as well as a host of component and add-on drums.

### MCT904XEP/C

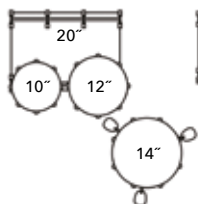

### MCT923XSP/C

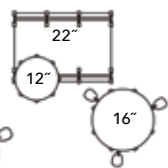

### MCT924XEP/C

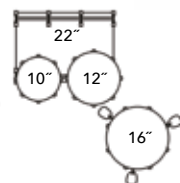

### MCT925XEP/C

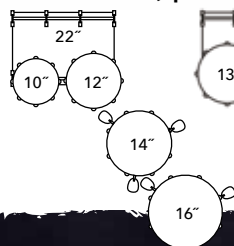

### MCT943XEP/C

(Special Order Only)

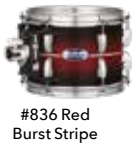
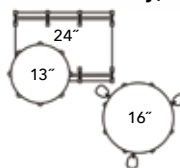



#414 Ice Blue Oyster  
MCT924XEP/C



**BEARING EDGE**  
Standard 45° - Pearl's original precision edge adds sustain through reduced shell-to-head contact.



**CL BRIDGE LUGS**  
A classic look with minimal shell contact at separate points for precise vibration control.



**HARDWARE**  
2.3mm SuperHoop II Hoops - Made to maintain tuning integrity in heavy play while delivering maximum shell resonance.

*Masters*  
**MAPLE COMPLETE**

# SESSION STUDIO SELECT

*A Completely New Take  
on the Full Spectrum Sound*

**A TRUE PEARL ORIGINAL, WITH  
A FRESH, GROOVE INSPIRING VIBE.**

Taking a tip from the Masterworks spectrum, Session Studio Select's unparalleled combination of Masters-grade Birch and African Mahogany deliver a refined standout for recording and gigging.



#851 Emerald Ash  
ST924XSP/C

# SESSION STUDIO SELECT



**BEARING EDGE**  
Outer 60-Degree.  
Increases volume and punch without harsh overtones.



**HARDWARE**  
SuperHoop II, 2.3mm Triple-Flanged hoops for rigid tuning stability without robbing the shell of sustain.

## HIGH GLOSS & SATIN LACQUER

## PREMIUM DELMAR WRAP



#851 Emerald Ash



#314 Gloss Barnwood Brown



#847 Scarlet Ash



#766 Black Mirror Chrome



#405 Nicotine White Marine Pearl (Large)



#405 Nicotine White Marine Pearl **STS925XSP/C** w/ added 8x7 Tom and 20x14 Gong Drum

### SESSION STUDIO SELECT

- SHELL EvenPly-Six (6-ply, 5.4mm) Birch/African Mahogany
- SNARE 14x5.5, 14x6.5, or 14x8 Matching Wood\*
- FINISH Premium Wrapped or High Gloss Lacquer
- HEADS Remo Pinstripe Clear Tom, Powerstroke3 Bass, UT Coated Snare
- TOM MOUNTS OptiMount Suspension System
- TOM ARMS Sold Separately
- HARDWARE Chrome
- HOOPS SuperHoop II 2.3mm Triple Flanged
- LUGS RL Lugs

\*Sold Separately

**SHELLS**  
EvenPly-Six Birch/African Mahogany. A unique sonic dichotomy of piercing projection, smooth low-end and pre-EQ'd punch.



**STS904XP/C**

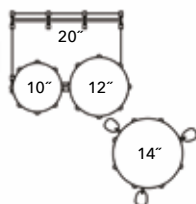

**STS924XSP/C**

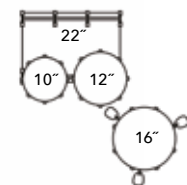

**STS925XSP/C**

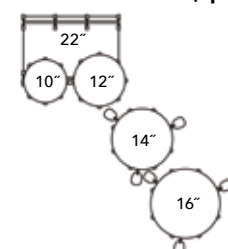

**STS943XP/C**  
(Special Order Only)

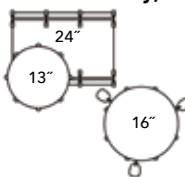

**STS983XP/C**  
(Special Order Only)

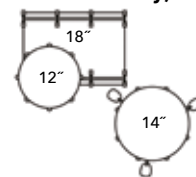

# PRESIDENT SERIES DELUXE

*A Modern Revival of The Darkly Unique Lauan Sound*

## DELIVERING A DISTINCTLY CLASSIC PLAYER'S GROOVE.

A modern take on a familiar favorite, President Series Deluxe drums revive our original 6-ply Lauan shell, the source of the original "MIJ" (Made in Japan) sound. This darker toned medium/hardwood was the basis of thousands of shells made by Mitsuo Yanagisawa in Pearl's Chiba, Japan-based drum factory starting in 1961.

Presenting prime vintage style without the shortcomings of yesterday's fittings, President Series Deluxe features a recasting of our classic "BattleShip" lug and adjustable tone mufflers on each drum. The elegant identity of Pearl's original script badge and classic bass drum logo augment the swirling flash of a choice of our Ripple covered finishes.

Each President Series Deluxe drum kit comes standard with Remo CS "Black Dot" UT heads, classic felt bass drum muffling strip, shell-mounted cymbal holder, and adjustable "Gullwing" style bass drum spurs.



#769 Sunset Ripple  
PSD924XP





**BEARING EDGE**  
Rounded 45° - Increased head-to-shell contact boosts mids and highs and helps control overtone spread.



**HARDWARE**  
2.3mm SuperHoop II Hoops - Made to maintain tuning integrity in heavy play while delivering maximum shell resonance.



**BSL LUGS**  
Cast in 1969 as "C043" for Pearl's professional outfits, it has since been dubbed "The Battleship Lug" by collectors for its angular profile. The new BSL100 features the same striking look and self-aligning design with a more robust casting for better tuning integrity.



#768 Desert Ripple  
**PSD943XP/C**

Drawing from the very origins of Pearl's drum manufacturing history, President Deluxe Series revives the warm subtlety of our original tone wood for a traditionally full, controlled playing experience.



#767 Ocean Ripple #768 Desert Ripple #769 Sunset Ripple

**PSD903XP/C**

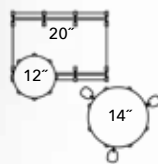

**PSD904XP**

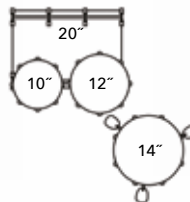

**PSD923XP/C**

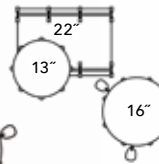

**PSD924XP**

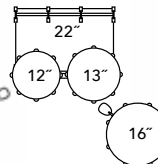

**PSD943XP**

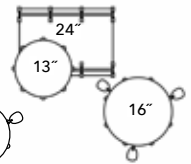

# PEARL

## PRESIDENT SERIES DELUXE

SHELL	6-ply 7.5mm Lauan
SNARE	14" x 5.5"*
FINISH	Premium USA Ripple Coverings Remo UT CS Black Dot Batters
HEADS	Anniversary Ed. Smooth White Coated Ambassador w/ Classic Pearl Logo BSP835 "Gullwing" Style
SPURS	CHB75LB
BD CYMBAL MOUNT	SuperHoop II 2.3mm Triple-Flanged
HOOPS	BSL100/BSL200/BSL55
LUGS	BDMF and Resonant Felt Strip
BD MUFFLER	

\*Sold Separately



#767 Ocean Ripple  
**PSD0810P/C**



Single-braced  
stand included.

### SINGLE-HEADED CONCERT TOM SET

A period-correct companion to President Series Deluxe shell packs. Includes 8"x6" and 10"x7" single headed toms with Traditional Slide/Clip mounts.



**SHELLS**  
6-ply 7.5mm Lauan. Loud yet subdued with deep, punchy wallop and plenty of top-end attack.

# CRYSTAL BEAT

The Original Seamless Acrylic Drum Shell



Originating in 1973, Pearl's Crystal Beat Acrylic drums feature a 7mm molded/seamless Acrylic shell for a vivid combination of cutting tonal power and stunning visual appeal.

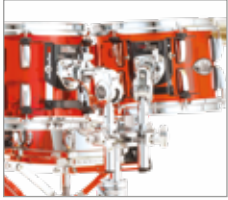

**HARDWARE**  
Toms include the OptiMount suspension system for increased sustain and 1.6mm triple-flanged hoops for attack and punchy tonal body.



#732 Tangerine Glass  
CRB543P/C



#731 Ruby Red  
CRB503P/C



**SHELLS**  
Loud and immediate, delivers pummeling straight tone and yielding feel. Dual 45° bearing edge with a rounded apex, adding control and increased articulation to acrylic's sonic signature.

## CRYSTAL BEAT

SHELL	6mm (7mm on Bass Drums) Seamless Molded Acrylic Matching Free Floater*
SNARE	Matching Free Floater*
FINISH	Transparent
HEADS	Transparent 2-Ply on Tom Batters Single-Ply Resonant
TOM MOUNTS	OptiMount Suspension System
TOM ARMS	Sold Separately
HARDWARE	Chrome
HOOPS	Chrome 1.6mm Triple-Flanged CB Mid-Lugs on Toms, CB Fat-Lugs on Bass
LUGS	

\*Sold Separately

CRB524P/C

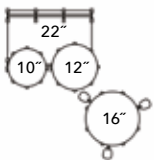

CRB524FP/C

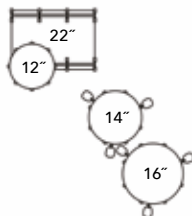

CRB504P/C

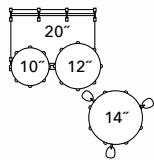

Individual components also available. For sizes, visit [www.pearldrums.com](http://www.pearldrums.com)



#730 Ultra Clear

#731 Ruby Red

#732 Tangerine  
Glass

# CRYSTAL BEAT



#730 Ultra Clear

# DECADE MAPLE

*A Drum Kit 10 Years in the Making*



#207 Ultramarine Velvet  
DMP926S/C

## DECADE MAPLE

**BUILT TO PUSH THE BOUNDARIES OF PERFORMANCE AND PRICE**

Decade Maple Series drums elevate the playing field for the advancing drummer with pro features and unbeatable value.

### DECADE MAPLE

SHELL	EvenPly-Six (5.4mm) 100% Maple
SNARE	Matching 14x5.5
FINISH	High-Gloss / Matte Lacquer
HEADS	Remo UT Clear Ambassador Tom, Ported UT Powerstroke3 Bass
TOM MOUNTS	Opti-Loc Mounting System
HARDWARE	Chrome
HOOPS	1.6mm Steel Triple Flanged
LUGS	NDL Lugs
BD MUFFLER	BDMM (Mini)



#261 Gloss Deep Red Burst  
DMP905P/C



#207 Ultramarine Velvet



#215 Satin Gold Meringue



#227 Satin Slate Black



#262 Satin Black Burst



#260 Satin Brown Burst



#261 Gloss Deep Red Burst

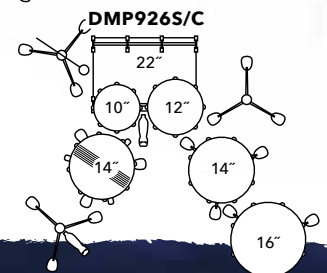
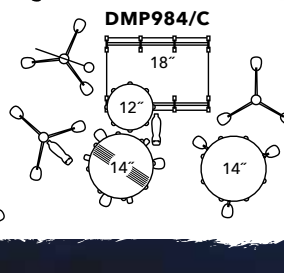
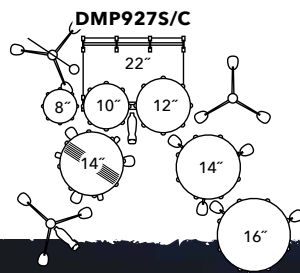
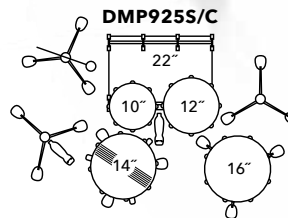
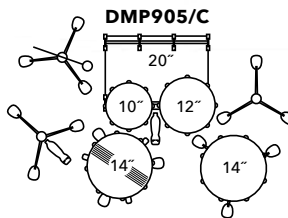



#### OPTI-LOC MOUNTING SYSTEM

This three-point isolation mount suspends the drum at two tuning points and one of the drum's air vents for solid, stable play.



#### HARDWARE

- Uni-Lock gearless Tom Arms.
- R40 Air Suspension Floor Tom feet.
- NDL Mini Lugs: For reliable, rock solid durability and sound.



#### SHELLS

6-ply/5.4mm Maple - Thin (but powerfully strong) Pearl's SST shell reacts quickly to the stroke with beautifully resonant highs and thundering lows.



#262 Satin Black Burst  
DMP927SP/C

# EXPORT LACQUER

*The Legends of Tomorrow, Play Export Today*



#217 Raspberry Sunset  
EXL725S/C

## EXPORT LACQUER

SHELL	6 Ply 7.5mm Birch/Poplar & Asian Mahogany Blend
SNARE	14 x 5.5 Matching Wood Snare
FINISH	Choice of 4 High Gloss Lacquer Finishes and 1 Satin Finish
HEADS	Remo Clear Tom Head, Powerstroke Bass Head
TOM MOUNTS	Opti-Loc Mounting System
DRUM	TH701
HARDWARE	Chrome
HARDWARE	P930, BC830, C830, H830, S830
BD MUFFLER	BDMM (Mini)



#211 Azure Daybreak



#217 Raspberry Sunset



#218 Ember Dawn



#219 Indigo Night

#31 Jet Black  
EXX725/C + EXX8P/C



### 830 SERIES HARDWARE

Sophisticated, sturdy, and efficient, Export's 830 Series Boom (BC830), Cymbal (C830), and Snare (S830) stands all feature gearless Uni-Lock Tilters for pinpoint positioning, and robust double-braced tripods for secure stability in play. The H830 Hi-Hat stand also features swivel legs that accommodate double pedals.

Drum Pedal  
P930



### P930 PEDAL

Featuring the longboard styling and feel of Pearl's Demon Drive pedal, the P930 offers two chain drive cam options for power, speed, and control.

### OPTI-LOC MOUNTING SYSTEM

Pearl's three way tom mount delivers wobble free stability by suspending the drum at two tuning points and one of the drum's two air vents.



# EXPORT

The Best Selling Drum Set of All Time



The Export Series 30 year pedigree of unbeatable quality and value shines on with Reference-inspired shell woods and high impact hardware, giving the rising player a truly high end playing platform.



#21 Smokey Chrome    #31 Jet Black    #735 Satin White    #704 Black Cherry Glitter    #717 High Voltage Blue

Export Series drums are available in three preconfigured packages with our robust 830 Series hardware; and feature a choice of gorgeous lacquer (EXL) or durable wrapped (EXX) finishes.



## EXPORT

SHELL	6-Ply 7.5mm Poplar/ Asian Mahogany Blend
SNARE	14 x 5.5 Matching Wood Snare
FINISH	Choice of 6 Covered Finishes
HEADS	Remo Clear Tom Head, Powerstroke Bass Head
TOM MOUNTS	Opti-Loc Mounting System
TOM ARMS	TH701
DRUM	Hardware
HARDWARE	Chrome
HARDWARE	P930, BC830, C830, H830, S830
BD MUFFLER	BDMM (Mini)

## SHELLS

6-ply/7.5mm Poplar/Asian Mahogany. A Pearl SST (Superior Shell Technology) blend for high volume resonance and sustained low-end punch.



## EXX725S/C EXL725S/C

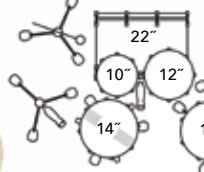

## EXX725/C EXL725/C

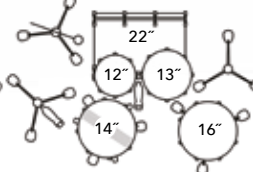

## EXX705N/C EXL705N/C

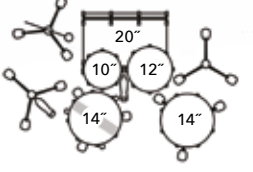

INCLUDES HWP830 HARDWARE PACK

# MIDTOWN

Big Gig, Small Rig, Huge Sound

## SETTING THE PULSE FOR THE METROPOLITAN GROOVE

Pearl's ultra portable Midtown Kit is the perfect sounding board for full size sound and play in a smaller footprint. Ideal for tight giggering spaces on a budget.

MDT764P/C

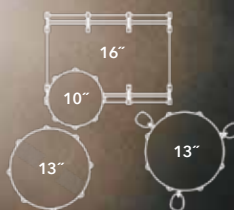

### MIDTOWN

SHELL	6 Ply (7.5 mm) Poplar
SNARE	Matching 13x5.5 Wood Snare Drum
FINISH	Choice of 3 Covered Finishes Remo UC Clear Tom
HEADS	Remo UC Clear Powerstroke Batter Bass Remo UC Coated Snare
TOM ARMS	TH701
HARDWARE	Chrome

**SHELLS**  
6 Ply (7.5 mm) Poplar. Quick and biting attack with lively overtones.

**INSTANTLY PORTABLE**  
The Midtown Kit's compact size quickly breaks down into two optional gig bags (PMTBG) for quick transport.

#33 Pure White  
MDT764P/C

Lift used on Midtown raises the drum to the optimal position for your pedal.

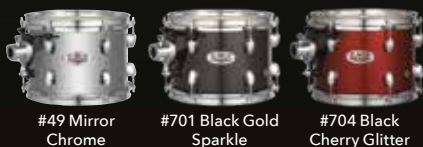

#49 Mirror Chrome #701 Black Gold Sparkle #704 Black Cherry Glitter

## ROCKET TOMS

For striking staccato tone that's both melodic and piercing, Pearl's Rocket Toms are 6" pitched toms in varying lengths made to expand the sonic palette of any drum kit.

Available in sets or as individual components in Aluminum. Finishes: #103 Piano Black, #109 Arctic White, or #730 Ultra Clear Acrylic.



AL0612	6" x 12"
AL0615	6" x 15"
AL0618	6" x 18"
AL0621	6" x 21"
ALX1215	6" x 12", 6" x 15" (w/ T890)
ALX1821	6" x 18", 6" x 21" (w/ T890)
CRB612/C	6" x 12" (Acrylic #730 Ultra Clear)
CRB615/C	6" x 15" (Acrylic #730 Ultra Clear)
CRB618/C	6" x 18" (Acrylic #730 Ultra Clear)
CRB621/C	6" x 21" (Acrylic #730 Ultra Clear)

## COMPACT TRAVELER

### COMPACT TRAVELER

BASS DRUM	18" w/ Base Frame & L-Arm Handle
SNARE	10" w/ Adjustable Snare Rake
STANDS	Sold Separately
CARRYING CASE	PSCPCTK (Sold Separately)
ADD ON PACK	PCTK1014 Includes 10" & 14" Toms w/ Mounting Hardware

Take the rhythm on the road with Pearl's totally portable, super playable, ultra affordable beat maker. Perfect for School, Street, Practice, and Stage.



Shown with PCTK1014 add on pack\* PCTK1810

Pedal sold separately PCTK1810

Add on pack (10" & 14" toms w/ mounting hardware) PCTK1014

Optional Compact Traveler Bag PSCPCTK

Optional Compact Traveler Add on Bag PSCPCTKADD

\*HW/Cymbals sold separately



# ROADSHOW



*It's Your Time to Play. Start the Right Way!*

## THE RHYTHM IS IN YOU

Drumming knows no age limit. Regardless of when your rhythmic journey starts, Pearl's Roadshow Series has a drum set package scaled for players of all ages that includes everything you need to get on the road to drumming greatness.

**SHELLS**  
Featuring a 9 ply Poplar shell for optimum tonal power.



## ROADSHOW

SHELL	9 Ply 7mm Asian White Poplar
SNARE	Matching Wood Snare
FINISH	Choice of 5 Covered Finishes
HEADS	Clear Tom Heads, Coated Snare Head, Self-Muffled Bass Head
TOM ARMS	Individually Locking 7/8" Tube Joint Holders Dual-Chain Drive Bass Drum Pedal
HARDWARE	Double-Braced Cymbal*, Snare and Hi-Hat Stands, Double-Braced Throne
CYMBALS	16" Brass Cymbal, 14" Brass/Hybrid Hi-Hat Cymbals
ACCESSORIES	Pro Drum Stick Bag, Two pairs of Maple 5A Sticks

For additional info, testimonials, free assembly and instructional videos, and access to the largest drummer's community on the web, go to:

[WWW.MYFIRSTDRUMSET.COM](http://WWW.MYFIRSTDRUMSET.COM)



#33 Pure White  
RS525SC/C



#31 Jet Black



#91 Red Wine



#707 Bronze Metallic



#743 Royal Blue Metallic

Complete Sets with Hardware, Cymbals, and Throne.

RS505C/C

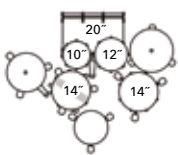

RS505BC/C

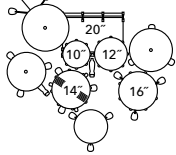

RS525SC/C

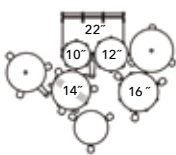

RS525BC/C

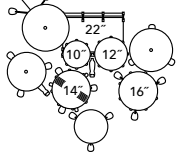

RS585C/C

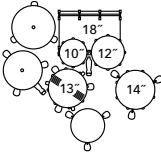

RS585BC/C

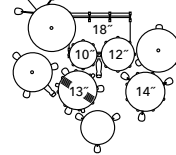

#743 Royal Blue Metallic  
RS525C/C

## ROADSHOW JR.

Pearl's Roadshow Jr. is NOT a toy. It's a serious, all-in-one, five piece drum set sized for kids under 8-years-old featuring hardware, cymbals, and sturdy White Poplar shell construction for an exceptionally powerful drumming start.

Complete with Hardware, Cymbals, and Throne for Drummers under 8.

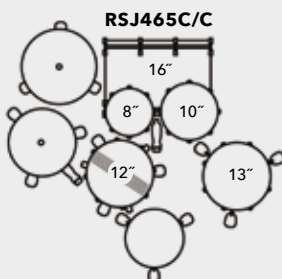

RSJ465C/C



#31 Jet Black  
RSJ465C/C

#708 Grindstone Sparkle  
RSJ465C/C

Also available in  
#33 Pure White

# SERIES COMPONENT

Reference, Reference Pure, President Series



**RF1450S/C** 14" x 5"

- SHELL 20 ply (25mm) Maple 14 + Birch 6
- HOOPS MasterCast (DC1410/1410S)
- LUGS BRL55
- RODS SST5047 Stainless Steel
- STRAINER SR1000 Glide-Lock Strainer
- SNARES SN1420D Ultra Sound "D" type



RF1450S/C



RFP1450S/C

**RFP1450S/C** 14" x 5"

- SHELL 6 ply (5.4 mm) Maple 4 + Birch 2
- HOOPS FatTone Hoops (FH1410/1410S)
- LUGS STL55L
- RODS SST5047 Stainless Steel
- STRAINER SR1000 Glide-Lock Strainer
- SNARES SN1420D Ultra-Sound "D" type

**RF1465S/C** 14" x 6.5"

- SHELL 20 ply (25mm) Maple 14 + Birch 6
- HOOPS MasterCast (DC1410/1410S)
- LUGS BRL65
- RODS SST5047 Stainless Steel
- STRAINER SR1000 Glide-Lock Strainer
- SNARES SN1420D Ultra Sound "D" type



RF1465S/C



RFP1465S/C

**RFP1465S/C** 14" x 6.5"

- SHELL 6 ply (5.4 mm) Maple 4 + Birch 2
- HOOPS FatTone Hoops (FH1410/1410S)
- LUGS STL65
- RODS SST5047 Stainless Steel
- STRAINER SR1000 Glide-Lock Strainer
- SNARES SN1420D Ultra-Sound "D" type

**RF1365S/C** 13" x 6.5"

- SHELL 20 ply (25mm) Maple 14 + Birch 6
- HOOPS MasterCast (DC1308/1308S)
- LUGS BRL65
- RODS SST5047 Stainless Steel
- STRAINER SR1000 Glide-Lock Strainer
- SNARES SN1320D Ultra Sound "D" type



RF1365S/C



RFP1365S/C

**RFP1365S/C** 13" x 6.5"

- SHELL 6 ply (5.4 mm) Maple 4 + Birch 2
- HOOPS FatTone Hoops (FH1308/1308S)
- LUGS STL65
- RODS SST5047 Stainless Steel
- STRAINER SR1000 Glide-Lock Strainer
- SNARES SN1320D Ultra-Sound "D" type

# PEARL

## PRESIDENT SERIES DELUXE

#767 DESERT RIPPLE



#767 Ocean Ripple  
PSD1455S/C



#768 Desert Ripple  
PSD1455S/C



#769 Sunset Ripple  
PSD1455S/C

**PSD1455SE/C** 14" x 5.5"

SHELL	6-ply 7.5mm Lauan
FINISH	#450 Silver Sparke #767 Desert Ripple #768 Ocean Ripple
HOOPS	SuperHoop II (SH1408B/1408S)
LUGS	BSL55
RODS	TO61L
MUFFLER	IM100W
STRAINER	SR17A / SR150E
SNARES	SN1420I



RFB1450



RFB1465

**RFB1450** 14" x 5"

SHELL	3mm Brass
HOOPS	MasterCast (DC1410/1410S)
LUGS	BRL55
RODS	SST5047 Stainless Steel
STRAINER	SR1000 Glide-Lock Strainer
SNARES	SN1420D Ultra-Sound "D" type

**RFB1465** 14" x 6.5"

SHELL	3mm Brass
HOOPS	MasterCast (DC1410/1410S)
LUGS	BRL65
RODS	SST5042 Stainless Steel
STRAINER	SR1000 Glide-Lock Strainer
SNARES	SN1420D Ultra-Sound "D" type



RFS1450



RFS1465

**RFS1450** 14" x 5"

SHELL	2.5mm Cast Steel / 2.5mm R-Ring
HOOPS	MasterCast (DC1410/1410S)
LUGS	BRL55
RODS	SST5047 Stainless Steel
STRAINER	SR1000 Glide-Lock Strainer
SNARES	SN1420D Ultra-Sound "D" type

**RFS1465** 14" x 6.5"

SHELL	2.5mm Cast Steel / 2.5mm R-Ring
HOOPS	MasterCast (DC1410/1410S)
LUGS	BRL65
RODS	SST5047 Stainless Steel
STRAINER	SR1000 Glide-Lock Strainer
SNARES	SN1420D Ultra-Sound "D" type



### GLIDE-LOCK STRAINER

All Reference snare drums feature Pearl's SR1000 Glide-Lock Strainer, which includes a locking throw off lever and tension knob that won't loosen no matter how hard you play. Low friction technology permits smooth gliding action for ultra quiet and super precise motion.

U.S. Patent #7220905, #7301087, #7365256

# SERIES COMPONENT

Masters, Session, & Decade  
Classic Pearl Sound



DRUM SET SERIES SNARE DRUMS Made to match the sound and feel of your Pearl drum set.

**MRV1455S/C** 14" x 5.5"

- SHELL 4 Ply Maple with 4 ply Maple Re-Rings
- HOOPS FatTone (FH1410/1410S)
- LUGS STL55
- RODS SST5055 Stainless Steel
- STRAINER SR017
- SNARES S022N



MRV1455S/C



MRV1465S/C

**MRV1465S/C** 14" x 6.5"

- SHELL 4 Ply Maple with 4 ply Maple Re-Rings
- HOOPS FatTone (FH1410/1410S)
- LUGS STL65
- RODS SST5047 Stainless Steel
- STRAINER SR017
- SNARES S022N

**MCT1455S/C** 14" x 5.5"

- SHELL 6 Ply Maple (5.4mm)
- HOOPS SuperHoop II (SH1410B/1410S)
- LUGS CL55
- RODS T062
- STRAINER SR017
- SNARES S022N



MCT1455S/C



MCT1465S/C

**MCT1465S/C** 14" x 6.5"

- SHELL 6 Ply Maple (5.4mm)
- HOOPS SuperHoop II (SH1410B/1410S)
- LUGS CL65
- RODS T061L
- STRAINER SR017
- SNARES S022N

**STS1480S/C** 14" x 8"

- SHELL 6-ply (5.4mm) Birch/African Mahogany
- HOOPS SuperHoop II (SH1410B/1410S)
- LUGS CL100
- RODS T061L
- STRAINER SR017
- SNARES S022N



STS1480S/C



STS1465S/C

**STS1465S/C** 14" x 6.5"

- SHELL 6-ply (5.4mm) Birch/African Mahogany
- HOOPS SuperHoop II (SH1410B/1410S)
- LUGS CL65
- RODS T061L
- STRAINER SR017
- SNARES S022N

**STS1455S/C** 14" x 5.5"

- SHELL 6-ply (5.4mm) Birch/African Mahogany
- HOOPS SuperHoop II (SH1410B/1410S)
- LUGS CL55
- RODS T062
- STRAINER SR017
- SNARES S022N



STS1455S/C



DMP1455S/C

**DMP1455S/C** 14" x 5.5"

- SHELL 6 Ply Maple (5.4mm)
- HOOPS 1.6mm Steel (RH1408/1408S)
- LUGS NDL55/C
- RODS TR5052
- STRAINER SR700
- SNARES SNW1420

# FREE FLOATING

The Ultimate Purity Of Sound

**TASK-SPECIFIC INNOVATION** Pearl's unique Free Floating Snare chassis removes all hardware from the shell to greatly improve resonance and projection.



By combining the tonal character of each shell type with its ideally matched depth, each Free Floating snare drum is engineered to fit a specific task by model and gives you a unique voice for any sonic situation.



**CLICK-LOCK THROW-OFF SYSTEM** Engineered with Polymer bearings for precise and smooth action. Unique nylon grip mechanism locks the snares into place.



**FTAL1480** Deep, rich snare power with short, even sustain decay.



**FTMH1480** Ultimate in throaty, deep snare growl. Shortened decay.

<b>FTAL1480</b>	14" x 8"
SHELL	1.2mm Seamless Aluminum
HOOPS	MasterCast (DC1410/DC1410S)
LUGS	FT80
RODS	SST5042
STRAINER	SR160F
SNARES	SN1442C

<b>FTMH1480</b>	14" x 8"
SHELL	8 ply (10mm) African Mahogany
HOOPS	MasterCast (DC1410/DC1410S)
LUGS	FT80
RODS	SST5042
STRAINER	SR160F
SNARES	SN1442C



**FTPB1465** Lower overtone body, preserves crisp top-end snare snap.



**FTMMH1465** Full, rounded bottom frequencies. Extra midrange body.

<b>FTPB1465</b>	14" x 6.5"
SHELL	1.2mm Phosphor Bronze
HOOPS	MasterCast (DC1410/DC1410S)
LUGS	FT65
RODS	SST5042
STRAINER	SR160F
SNARES	SN1420C

<b>FTMMH1465</b>	14" x 6.5"
SHELL	6 ply (7.5mm) 4 ply Maple w/ 2 ply Inner African Mahogany
HOOPS	MasterCast (DC1410/DC1410S)
LUGS	FT65
RODS	SST5042
STRAINER	SR160F
SNARES	SN1420C



**FTBR1450** Full-spectrum, both bright in punch and warm in tone.



**FTMM1450** Punchy and smooth. A perfect "go-to" snare.

<b>FTBR1450</b>	14" x 5"
SHELL	1mm Brass
HOOPS	MasterCast (DC1410/DC1410S)
LUGS	FT50
RODS	SST5042
STRAINER	SR160F
SNARES	SN1420I

<b>FTMM1450</b>	14" x 5"
SHELL	6 ply (7.5mm) Maple
HOOPS	MasterCast (DC1410/DC1410S)
LUGS	FT50
RODS	SST5042
STRAINER	SR160F
SNARES	SN1420I



**FTSS1435** 1mm shell for bright, open attack with ringy overtone.



**FTBB1435** Dense all Birch shell delivers bright, open attack.

<b>FTSS1435</b>	14" x 3.5"
SHELL	1mm Stainless Steel
HOOPS	MasterCast (DC1410/DC1410S)
LUGS	FT35
RODS	SST5035
STRAINER	SR160F
SNARES	SN1420D

<b>FTBB1435</b>	14" x 3.5"
SHELL	6 ply (5.4mm) Birch
HOOPS	MasterCast (DC1410/DC1410S)
LUGS	FT35
RODS	SST5035
STRAINER	SR160F
SNARES	SN1420D

# SENSITONE HERITAGE ALLOY

*Legendary Snare Tone  
from Studio to Stage*



The Sensitone sound has always been drawn from an amalgamation of The Heritage Alloys (Aluminum, Black-over-Brass, and Steel) for the necessary, immediate tones of yesterday's chart toppers with an undeniably modern sensibility.

Sensitone Heritage Alloy snare models employ these three original metal shell types to deliver essential tone and power with the right gig-ready touches.

**STH1465BR**

**STH1450AL** 14" x 5.5"

SHELL 1.2mm Seamless Aluminum  
HOOPS SuperHoop II (SH1410B/1410S)  
LUGS CL55  
RODS T061L  
STRAINER SR017  
SNARES SN1420I



**STH1450AL** Dry, focused crack with quick decay.



**STH1465AL** Full, guttural snare bellow with little overtone.

**STH1465AL** 14" x 6.5"

SHELL 1.2mm Seamless Aluminum  
HOOPS SuperHoop II (SH1410B/1410S)  
LUGS CL65  
RODS T061L  
STRAINER SR017  
SNARES SN1420I

**STH1450BR** 14" x 5.5"

SHELL 1mm Beaded Brass  
HOOPS SuperHoop II (SH1410B/1410S)  
LUGS CL55  
RODS T061L  
STRAINER SR017  
SNARES SN1420I



**STH1450BR** Perfect blend of attack and brassy body.



**STH1465BR** An elegant solution for punch and warmth.

**STH1465BR** 14" x 6.5"

SHELL 1mm Beaded Brass  
HOOPS SuperHoop II (SH1410B/1410S)  
LUGS CL65  
RODS T061L  
STRAINER SR017  
SNARES SN1420I

**STH1450S** 14" x 5"

SHELL 1mm Beaded Steel  
HOOPS SuperHoop II (SH1410B/1410S)  
LUGS CL55  
RODS T061L  
STRAINER SR017  
SNARES SN1420I



**STH1450S** Crisp, sensitive high-pitched snap.



**STH1465S** Belting crack with mild midrange overtone.

**STH1465S** 14" x 6.5"

SHELL 1mm Beaded Steel  
HOOPS SuperHoop II (SH1410B/1410S)  
LUGS CL65  
RODS T061L  
STRAINER SR017  
SNARES SN1420I

# SIGNATURE SNARES

Capturing The Exclusive Sound  
of Drumming Legends



MM1465S/C

## INTRODUCING THE WORLD'S FIRST "SMART" SNARE DRUM.

**MATT MCGUIRE**  
The Chainsmokers



*Any snare drum I play has to cut through and connect. Not just a sonic connection when it's played, but actual, exclusive interaction between players.*

*This is my Snare Drum. It's YOUR snare drum, and I can't wait for you to experience it.*

PHOTO: DANILLO LEWIS

### MATT MCGUIRE

**MM1465S/C** 14" x 6.5"

SHELL	1mm Steel/Black Shell
HOOPS	SuperHoop II (SH1410/1410S)
LUGS	CL65
RODS	TO61L
STRAINER	SR017
SNARES	SN1420I
FINISHES	Custom Black
VENTS	30x

Made to bring the arena-filling sound to any drummer who plays it, the Matt McGuire Signature Snare features a 1mm Rolled Steel shell with 30 reinforced vents around the bottom edge. This unique design channels the force of each hit through its 6.5" deep chamber and outward in every direction like a shock wave. Its powder coated Matte Black finish further tempers its uniquely bright tone and Pearl's reliably durable SuperHoop II 2.3mm Hoops and CL Bridge Lugs add weight for increased projection.



### NFC CHIP TECH

This Tour Edition drum is the first to feature imbedded NFC Chip technology. A simple tap with any Smartphone instantly unlocks exclusive content created by Matt himself.

# SIGNATURE SNARES



## MATT HALPERN

**MH1460B** 14" x 6"

- SHELL 1.5mm Black Powder-Coated Brass
- HOOPS MasterCast (DCB1410/1410S)
- LUGS STL55MH/B
- RODS SST5052
- STRAINER SR150
- SNARES SN14201
- FINISHES Custom Black
- VENTS AH03 (x3)

A Snare Drum from the Outer Limits of the Edge.



## BRIAN FRASIER-MOORE

**BFM1455S/C** 14" x 5.5"

- SHELL 12-Ply, 15mm Gum/Maple/Gum
- HOOPS MasterCast (DC1410/DC1410S)
- LUGS CL55
- RODS T062
- STRAINER SR150
- SNARES SN14421
- FINISHES Gloss Gumwood Naturalburst

A Truly Inspiring Snare Drum.



## DENNIS CHAMBERS

**DC1450S/N** 14" x 5"

- SHELL Cast Aluminum: 3mm w/ 2mm R. Rings
- HOOPS SuperHoop II (SHN1412B/1408S)
- LUGS STL100 (12 over 8)
- RODS SST5047 Stainless Steel (20)
- STRAINER SRO20 Multi-Trace Strainer System
- SNARES SN14201
- FINISHES Black Nickel Shell w/ Nickel Hardware

A Commanding Snare Sound Fit For Royalty.







**IAN PAICE**

**IP1465** 14" x 6.5"

- SHELL Beaded Steel Shell
- HOOPS SuperHoop II (SH1410B/1410S)
- LUGS TB65 w/ TL20
- RODS SST5042 Stainless Steel (10)
- STRAINER SR017
- SNARES S022N
- FINISHES Chrome-Plated

A Timeless, Innovative Collaboration with a True Rock Legend.



**OMAR HAKIM**

**OH1350** 13" x 5"

- SHELL 6 ply African Mahogany Shell
- HOOPS 2.3mm SuperHoop II (SH1308/1308S)
- LUGS CL55
- RODS SST5047 Stainless Steel (8)
- STRAINER SR015 Gladstone Style
- SNARES S029N
- FINISHES #140 Natural Mahogany

A "Power Piccolo" for a Sonic Blend of Power, Projection and Tonal Color.



**JOEY JORDISON**

**JJ1365N** 13" x 6.5"

- SHELL Steel/Black Shell
- HOOPS SuperHoop II (SHB1308/1308S)
- LUGS CL65B
- RODS SST5047 Stainless Steel (10)
- STRAINER SR017/B
- SNARES S029N
- FINISHES Custom Black

A Fierce, Ferocious, Fast Snare fit for a Metal Drumming Legend.



# HYBRID EXOTIC

For the ultimate in power and prestige. Shell choices include spun-composite, seamless Cast Aluminum, and Kapur/Fiberglass.

Space-Age Precision,  
Timeless Tone



## HEP1450 14" x 5"

SHELL VectorCast  
HOOPS SuperHoop II (SH1410B/1410S)  
LUGS STL100  
RODS SPT5047 (top) - SST5047 (bottom)  
STRAINER SR1000  
SNARES SN1420C



**HEP1450** Quick, yielding snap with heavy midrange overtones.

## HEP1465 14" x 6.5"

SHELL VectorCast  
HOOPS SuperHoop II (SH1410B/1410S)  
LUGS STL100  
RODS SPT5047 (top) - SST5047 (bottom)  
STRAINER SR1000  
SNARES SN1420C



**HEP1465** Full-Spectrum snare body with thick bottom-end tonality.

# DUOLUXE

The World's First Inlaid Brass Snare Drum



The Pearl Duoluxe is a modern take on our legendary, "interplanetary" snare drum sound. Featuring the chrome-over-brass shell alloy of our classic Jupiter snare, the rigidity of our trademark dual inverted shell beads is augmented with inlaid finish bands of Nicotine White Marine Pearl. This gives the shell a singular look and adds tonal control to its unbridled sound.

Each DuoLuxe snare is fitted with retro-perfect "Battleship" Lugs, smooth SR017 Strainer, and solid 2.3mm SuperHoop II triple-flanged hoops to balance out the package. Experience the Jupiter sound with a fresh, dynamic look for a totally graceful drumming presence.

## DUX1450BR 14" x 5"

SHELL 1mm Dual-Beaded Chrome/Brass  
HOOPS SuperHoop II (SH1410B/1410S)  
INLAY #405 Nicotine White Marine Pearl (x2)  
LUGS BSL55  
RODS SST5042  
STRAINER SR017  
SNARES SN1420I



**DUX1450BR** Bold and crisp with short midrange overtone.

## DUX1465BR 14" x 6.5"

SHELL 1mm Dual-Beaded Chrome/Brass  
HOOPS SuperHoop II (SH1410B/1410S)  
INLAY #405 Nicotine White Marine Pearl (x2)  
LUGS BSL55  
RODS SST5055  
STRAINER SR017  
SNARES SN1420I



**DUX1465BR** Fierce and centered mid-to-low sustain.

**GLIDE-LOCK THROW-OFF SYSTEM** Pearl's SR1000 Glide-Lock Strainer's locking throw-off lever and tension knob assures worry free, slip-free performance from all Hybrid Exotic Snare Drums. (U.S. Patent #7220905, #7301087, #7365256.)



**SPIN-TIGHT™ TENSION RODS** To maintain tuning tension across the batter head, all Hybrid Exotic snare drums feature Pearl's Spin-Tight tension rods. This elegantly simple innovation creates a tension rod-within-a-tension rod, that allows the rod to expand and lock into place within the swivel nut. Utilizing a special drum key, tunings can be controlled under high-impact play like never before.



**HEAL1450** Dry, high-pitched crack with little overtone.



**HEK1450** Articulate snare punch, best at higher tunings.

<b>HEAL1450</b>	14" x 5"
SHELL	Cast Aluminum: 3mm w/ 2mm R-Rings
HOOPS	SuperHoop II (SH1410B/1410S)
LUGS	STL100
RODS	SPT5047 (top) - SST5047 (bottom)
STRAINER	SR1000
SNARES	SN1420I

<b>HEK1450</b>	14" x 5"
SHELL	6 ply 7.5mm Kapur w/ Inner Fiberglass
HOOPS	SuperHoop II (SH1410B/1410S)
LUGS	STL100
RODS	SPT5047 (top) - SST5047 (bottom)
STRAINER	SR1000
SNARES	SN1420D

# STAVECRAFT

Featuring The Exclusive Dado-Loc Joint

A startling addition to any pro drummer's soundscape, each StaveCraft shell starts from two layers of meticulously beveled solid Makha or ThaiOak staves. Dado-Loc, an old world principal exclusive to these snares, inserts a segment of corresponding wood into the center Dado channel formed by each stave and increases total shell strength by 50%. This solid fusion of hardwoods is lathed to a perfectly round 25mm thickness for unparalleled volume and power.



StaveCraft available in #186 Hand Rubbed Satin Natural Finish



**SCD1450TO186** Quick, tight high-range tonal power.



**SCD1465TO186** Sensitive, centered low-overtone drive.

<b>SCD1450TO186</b>	14" x 5"
SHELL	25mm Dual Thai Oak Stave w/ Makha DadoLoc
HOOPS	MasterCast (DC1410/DC1410S)
LUGS	STL55L
RODS	SST5042
STRAINER	SR150 ClickLock
SNARES	SN1420I

<b>SCD1465TO186</b>	14" x 6.5"
SHELL	25mm Dual Thai Oak Stave w/ Makha DadoLoc
HOOPS	MasterCast (DC1410/DC1410S)
LUGS	STL65
RODS	SST5047
STRAINER	SR150 ClickLock
SNARES	SN1420I



**SCD1450MK186** Cracking tonal pop with short midrange hum.



**SCD1465MK186** Thick, cavernous sonic body with cutting punch.

<b>SCD1450MK186</b>	14" x 5"
SHELL	25mm Dual Makha Stave w/ Thai Oak DadoLoc
HOOPS	MasterCast (DC1410/DC1410S)
LUGS	STL55L
RODS	SST5042
STRAINER	SR150 ClickLock
SNARES	SN1420I

<b>SCD1465MK186</b>	14" x 6.5"
SHELL	25mm Dual Makha Stave w/ Thai Oak DadoLoc
HOOPS	MasterCast (DC1410/DC1410S)
LUGS	STL65
RODS	SST5047
STRAINER	SR150 ClickLock
SNARES	SN1420I

# UTILITY

**MODERN UTILITY** snare drums are vital instruments to make the gig great. Fusing reliability and flexibility for today's demanding gigging environment, Pearl has developed Modern Utility: a line of no-nonsense, well-appointed snare drums priced with the active working player in mind. Flexible enough to add to any setup and strong enough to stand up to constant play.



See Korn drummer Ray Luzier's performance test of each Modern Utility snare at [pearldrum.com](http://pearldrum.com)



Leg Brackets:  
FTB07 (x3)

Versatile Drums for Secondary Effects

## MUS1410FM 14" x 10"

SHELL 6 ply Maple (5.4mm)  
HOOPS 1.6mm Steel (RH1408/1408S)  
LUGS CL100  
RODS TR5052 (16)  
STRAINER SR017  
SNARES SNW1420  
FINISHES Satin Brown (#220)

## MUS1480M 14" x 8"

SHELL 6 Ply Maple (5.4mm)  
HOOPS 1.6mm Steel (RH1408/1408S)  
LUGS CL100  
RODS TR5052 (16)  
STRAINER SR017  
SNARES SNW1420  
FINISHES #224 Matte Natural, #227 Satin Black

## MUS1455M 14" x 5.5"

SHELL 6 ply Maple (5.4mm)  
HOOPS 1.6mm Steel (RH1408/1408S)  
LUGS CL55  
RODS TR5052 (16)  
STRAINER SR700  
SNARES SNW1420  
FINISHES #224 Matte Natural, #227 Satin Black

## MUS1465M 14" x 6.5"

SHELL 6 ply Maple (5.4mm)  
HOOPS 1.6mm Steel (RH1408/1408S)  
LUGS CL65  
RODS TR5047 (16)  
STRAINER SR700  
SNARES SNW1420  
FINISHES #224 Matte Natural, #227 Satin Black

## MUS1350M 13" x 5"

SHELL 6 ply Maple (5.4mm)  
HOOPS 1.6mm Steel (RH1308/1308S)  
LUGS CL55  
RODS TR5047 (16)  
STRAINER SR700  
SNARES SNW1316  
FINISHES #224 Matte Natural, #227 Satin Black

## MUS1270M 12" x 7"

SHELL 6 ply Maple (5.4mm)  
HOOPS 1.6mm Steel (RH1206/1206S)  
LUGS CL65  
RODS TR5057 (12)  
STRAINER SR017  
SNARES SNW1216  
FINISHES #224 Matte Natural, #227 Satin Black



MUS1410FM



MUS1480M



MUS1455M



MUS1465M



MUS1350M



MUS1270M

# EFFECTS

Added Voices, Timbres, and Sounds in Your Ever-Evolving Setup



**SFS10/C31** 10" x 4.5"

SHELL 6 Ply Poplar  
HOOPS 1.6mm Steel (RIM1006RSH/RIM1006RSH)  
LUGS MSFL35  
RODS RSHT3240 (12)  
STRAINER SR02MSFL/SR02EMSFL  
SNARES SN10MSFL



**M1060** 10" x 6"

SHELL 6 Ply Maple (7.5mm)  
HOOPS Super Hoop II (SH1006/1006S)  
LUGS CL65  
RODS SST5035 (12)  
STRAINER SR018  
SNARES S032N



**M1270** 12" x 7"

SHELL 8 Ply Maple (10mm)  
HOOPS 1.6mm Steel (RIM1208B/1208S)  
LUGS CL100  
RODS SST5047 Stainless Steel (16)  
STRAINER SR018  
SNARES S031N

EFFECTS SNARES



**B1330** 13" x 3"

SHELL 1.0mm Brass  
HOOPS 1.6mm Steel (RIM1308B/1308S)  
LUGS CL05  
RODS T055 (16)  
STRAINER SR018  
SNARES S029N



**S1330B** 13" x 3"

SHELL 1.0mm Black-finish Steel  
HOOPS 1.6mm Steel (RIM1308B/1308S)  
LUGS CL05  
RODS T055 (16)  
STRAINER SR018  
SNARES S029N



**M1330** 13" x 3"

SHELL 6ply Maple (7.5mm)  
HOOPS 1.6mm Steel (RIM1308B/1308S)  
LUGS CL05  
RODS T055 (16)  
STRAINER SR018  
SNARES S029N

PICCOLO



**FCP1250** 12" x 5"

SHELL 8 ply Poplar (10mm)  
HOOPS 1.6mm Steel (RIM1206/1206SL)  
LUGS CL50  
RODS T061L (12)  
STRAINER SR018  
SNARES S031



**FCS1050** 10" x 5"

SHELL 1.0mm Steel  
HOOPS 1.6mm Steel (RIM1006/1006SL)  
LUGS CL50  
RODS T061L (12)  
STRAINER SR018  
SNARES S032

FIRECRACKER

# COLLABORATION

CASEY COOPER @COOP3RDRUMM3R



**CC1450S/C** 14" x 5"

SHELL 6-ply 6.8mm Poplar/Maple  
HOOPS 1.6mm Steel (RH1408/1408S)  
LUGS CL55  
RODS TR5047 (16)  
STRAINER SR700  
SNARES SNW1420  
FINISHES Artisan II Flame Wrap



**THE IGNITER** To capture the searing energy of drumming for a new generation of players, Pearl collaborated with viral video drummer Casey Cooper to create The Igniter. Specifically created to instantly improve the sound of any student drum kit, it's a fantastic value to keep the fire of drumming burning bright!



# e/MERGE

Powered by  
KORG



10", 12" and 14" toms, a 14" snare, and PUREtouch Kick Pad. PUREtouch Cymbals, ICON e-Rack, MDL1 Module.  
**EM53T**

10", 12" and 14" toms, a 14" snare, and PUREtouch Kick Pad. PUREtouch Cymbals, ICON e-Rack, MDL1 Module + additional 15" CYMBAL PAD, Cymbalholder and Rackclamp.  
**EM53TC**



## e/TRADITIONAL CONFIGURATIONS

# e/MERGE

**NOT JUST A NEW STANDARD.  
A NEW SOUND. A NEW FEEL. AND, A  
COMPLETELY NEW E-DRUMMING EXPERIENCE.**

e/MERGE is about change, and change in the e-drum market has been way overdue. When we looked closely at every aspect of the current e-drumming experience with KORG, together we knew we could make a dramatic difference. And that difference begins with the all new e/MERGE module. Simple yet elegant in design, the e/MERGE MDL1 module features a full library of high definition, natural, organic and minimally processed acoustic Pearl drums. We then added the very best electronic, world, orchestral and specialty percussion sounds from KORG's vast library of pristine quality samples. But, the module is only part of the change.

There are three key elements that separate e/MERGE from anything that has come before. The MDL1 e/MERGE Module, KORG's amazing WAVE TRIGGER TECHNOLOGY and Pearl's acoustic-like PUREtouch electronic pads and cymbals combine to create an exceptional e-drumming experience.



MDL1

**e/MERGE MDL1 MODULE** Simple, straight forward yet extremely powerful, the MDL1 module offers, a pair of powerful multicore processors, a full library of acoustic Pearl drums recorded in one of the world's most renowned studios, pristine samples from KORG's library and the variety of routing options every e-drummer needs.

## EMHWP

The foundation of the e/MERGE electronic drum set is a custom designed, chrome plated ICON e-Rack system.



10", 12" and 14" toms, a 14" snare, and 18" acoustic bass drum. PUREtouch Cymbals, ICON e-Rack, MDL1 Module.  
**EM53HB**

10", 12" and 14" toms, a 14" snare, and 18" acoustic bass drum. PUREtouch Cymbals, ICON e-Rack, MDL1 Module + additional 15" CYMBAL PAD, Cymbalholder and Rackclamp.  
**EM53HBC**



## e/HYBRID CONFIGURATIONS



### WAVE TRIGGER TECHNOLOGY

This ultra-fast and highly sensitive technology partially based upon KORG's groundbreaking Wave Drum allows even your stick choice to make a discernible difference in the sound of your drum. Wave Trigger Technology speed adds a realism to the playing experience never before available to the e-drummer.



## PUREtouch

### PUREtouch PADS & CYMBALS

Perfectly sized pads designed to replicate the ultimate acoustic-like response. PUREtouch features layer upon layer of specially designed materials each selected for a specific quality that together create an e-experience never before possible. (PUREtouch Pads U.S. Patent #10475424) (PUREtouch Hi-Hats U.S. Patents #10475430, 10482855)



## MODULE SPECIFICATIONS



<b>SOUND GENERATOR</b>	2 CPU (4 core + 2 core) 128 Voices
<b>POLYPHONY</b>	700 HD Sound Library
<b>VOICE</b>	35 HD Kits
<b>DRUM KIT</b>	36
<b>EFFECTS</b>	44.1kHz, 16 Bit WAV
<b>SONG RECORDING TIME</b>	Approximately 12 Hours
<b>SONG RECORDING TIME</b>	BPM 30 - 300
<b>CLICK TEMPO</b>	1/2 - 24/2, 1/4 - 24/4, 1/8 - 24/8, 1 - 24/8T,
<b>BEAT</b>	1/16 - 24/16 (T=Triplet) 10
<b>CLICK VOICES</b>	Knobs and Ambient Slider Control
<b>CONTROLLERS</b>	3.25" x 1" Graphic LCD
<b>DISPLAY</b>	Master Out L/Mono & R
<b>CONNECTORS</b>	Direct Out (8) Headphones Out Aux In TRS Mini Main Trigger inputs (DB-25 Connector) Accessory Inputs (3) USB to PC Port (Transport USB Audio & MIDI Data) USB-A (for WAV files and Settings Data) MIDI Output
<b>MIDI</b>	
<b>POWER SUPPLY</b>	100-120V, 50-60Hz, Switching Power Supply
<b>DIMENSIONS, WEIGHT</b>	2.2lbs, 9" W x 7.5" D x 2" H

# MIMIC PRO



Download MIMIC PRO Software  
Updates and User Manual at  
[pearl-electronics-support.com](http://pearl-electronics-support.com)

Powered by Slate



MIMP24B

## MIMIC PRO POWERED BY SLATE

### STATE OF THE ART FEATURES:

- 7" IPS Touch Screen with Programmable Data Wheel
- 120 gig Solid State drive
- 16 Dual Zone Inputs
- 16 Programmable Audio Outputs
- MIDI In and Out
- High Quality Digital to Analog Converters
- Two completely separate mixers for headphone and Main outs (Drummer gets a personal mix with and without effects independent of Main outputs)
- Import Wave, Aiff or MP3 sound files
- Compatible with most pads on the market
- Steven Slate Drums 5 Library
- 24 bit multi channel sample library with separate adjustment of Close, Overhead and Room mics
- Onboard effects include EQ, Compression, Reverb with Room Sizes
- Individual Cymbal Volume Adjustments for Bell, Bow, Edge, Chik and Splash
- All AUX and Cymbal inputs have choke function
- Supports triple and dual zone cymbals and dual zone hi hat
- SD card slot and USB
- Additional Instruments and Libraries will be available
- Stereo Aux In and Onboard Metronome
- Internal Recording for Loops and/or Performances

**THE MOST AMAZING  
DRUM MODULE  
THE WORLD HAS  
EVER KNOWN.**

*SERIOUSLY,  
IT'S THAT GOOD.*



Superior sound, accurate triggering and connectivity are the most important features of a drum module. Pearl Drums and Steven Slate have joined forces to create "Mimic Pro" - the world's most advanced percussion sound source for studio and live performance applications.

At the heart of this ground breaking unit is the new Steven Slate 5 drum library that features multi-channel drum samples recorded in world class studios. Each instrument supports adjustment of Attack, Sustain, Release, Tune, Pan and volume. Instead of substituting digital effects to create ambience, these instruments use the actual ambient recordings with separate adjustment of close, overhead and room mics.

Mimic Pro is the first drum module to implement a 7" IPS touch screen and the first to offer 2 mixers for independent headphone and front house outputs. Now that the drummer is responsible for triggering loops and other sounds for a performance, Mimic Pro can import audio files to trigger from your pads.

Storage is no longer a problem with Mimic's 120GB Solid State Drive and lightning fast loading time. Speaking of connectivity, Mimic Pro is compatible with Pearl TruTrac pads and a host of pads from other manufacturers. Top that off with sixteen audio outs, 16 Trigger inputs, independent SD card Slot, USB and Midi In & Out, Stereo Aux input and you would be hard pressed to find a better option for today's musician.





# malletSTATION

The World's First 3.0 Octave Adjustable Range  
Electronic Mallet Controller

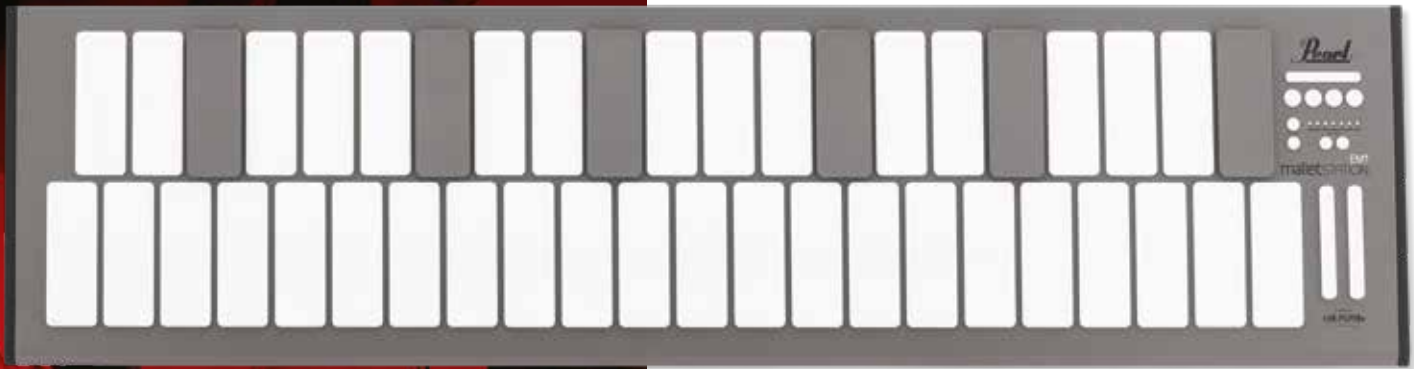

Shown Mounted on Vibraphone with Field Frame



Sleek, modern design with an ultra thin 1.6" profile



1.75" x 5" Soft Silicone Keys powered by KMI Smart Fabric Sensor Technology

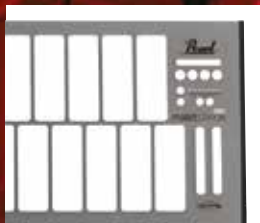

Software Assignable Control Panel with 3 Faders, 4 Buttons, plus Low Note and Octave Shift

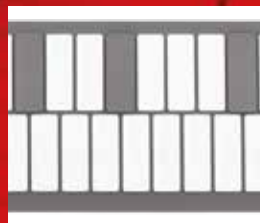

Moveable Accidental "Gap Caps" for visual cues when low note range is adjusted



Jack panel with USB MIDI, MIDI expander port, and 3 MIDI assignable 1/4" pedal inputs



Optional Dual Module Mounts allow malletSTATION to easily mount on racks, stands, and field frames

EM1

## malletSTATION™

**PRACTICE, PERFORM, COMPOSE ANYWHERE.**

- USB Powered MIDI Mallet Keyboard Controller
- Universal Compatibility through phone/tablet/laptop
- Tech-Forward Design featuring KMI Smart Fabric Sensors
- Low Note, Adjustable, User defined 3.0 Octave Range
- Customizable mallet dampening and aftertouch modes for realistic performance techniques
- Natural feeling soft silicone keys, all-weather playing surface
- Assignable buttons and faders for customized control and functions
- Three assignable pedal inputs for expression and sustain
- Hybrid Aluminum and Steel Chassis design for durability and stability
- Optional MIDI Expander to use external MIDI Hardware (sold separately)
- Flexible mounting on desktop, X-stand, or module mounts (sold separately)
- Mounting plates, stands, cases, covers, and other peripherals (available separately)

- 43, 1.75" x 5" soft silicone keys • 3 faders and 4 buttons, MIDI assignable
- 3 MIDI assignable 1/4" pedal inputs • Bottom Note Range Shift up/down buttons
- Octave up/down buttons • 1.6" H x 12.6" W x 49" L • 22.5 lbs

Pearl once again redefines the electronic percussion experience by introducing the revolutionary EM1 malletSTATION adjustable range electronic mallet controller.

The EM1 malletSTATION is a 3.0 octave adjustable range electronic mallet controller designed for all levels of player, from the beginning student through the gigging professional. The adjustable range function allows you to set the fundamental diatonic note of the instrument to what you need—low D xylophone? No problem! Powered exclusively by USB Bus Power, the malletSTATION is designed to be used with Mac, PC, iPad, iPhone, and Android devices, making it the first truly portable mallet percussion controller on the market.

Designed in collaboration with Keith McMillen Instruments, malletSTATION's tech-forward design features KMI's Smart Fabric Sensor technology allowing the silicone bar material to have an extremely sensitive, natural response, including mallet dampening and aftertouch control, and all can be easily tailored to your individual playing style. The EM1 features a master control section, with 3 programmable faders, 4 programmable buttons, and the fixed function low note and octave shift buttons. In addition, three assignable pedal inputs allow for flexibility in performance such as sustain, expression, or any MIDI parameter of your choice. These controls are fully programmable through a software editor so changing your configuration is as easy as clicking a mouse.

This is the controller that will grow with you throughout your playing career—from music apps on your phone or tablet, to professional digital audio workstations and sound libraries—your sounds and even the instruments you play are only limited by the software you run.

# DEMON PEDALS

The Fastest, Smoothest, Most Powerful Pedals in the World

## DEMON DRIVE UNLEASH THE DEMON

Demon Drive's lightning fast power and silky smooth finesse make it the choice of the drumming world's most prolific players. Featuring an amazing array of adjustable features, from beater angle, traction plate grip, and footboard height and angle, Demon Drive truly becomes an extension of your body. Its totally modular design makes it configurable in a variety of single and double pedal setups. Unleash the Demon and find out what custom feel is all about.



U.S. Patent #7579540

A choice of 2 positions for a finesse or power feel. Simply loosen the clamshell to change position.



**DIRECT LINK**  
Dual position adjustment for LIGHT or HEAVY feel, creating a seamless link between your foot and the bass drum.

### P3000D DEMON DRIVE

- |                           |                                   |
|---------------------------|-----------------------------------|
| DRIVE FOOT BOARD          | Direct Drive Duo-Deck Convertible |
| LINK ADJUSTMENT           | Dual Position Control Core        |
| BEATER TENSION ADJUSTMENT | Click-Lock                        |
| PEDAL HEIGHT              | Infinitely Adjustable             |
| BEATER ANGLE              | Infinitely Adjustable             |
| CASE                      | Included                          |



**CLICK-LOCK**  
Secures spring tension in high impact play. (U.S. Patent #7754953)



**DUO-DECK FOOTBOARD**  
The world's first convertible footboard can switch from a traditional shortboard to a longboard pedal in seconds. (U.S. Patent #7626107)



CONTROL CORE BEATERS

INDEPENDENT BEATER ANGLE AND FOOTBOARD HEIGHT ADJUSTMENTS



**DEMON DRIVE BEATER** w/ Control Core Elastomer Center: Reduces impact vibration. (U.S. Patent #7626108)



**NINJA BEARINGS**  
Designed for Pro Skateboarding, each bearing features micro-polished balls for minimal friction and unmatched speed.



Direct Drive Double Pedal (Shown In Longboard Setting) **P3002D**

- |  |                |
|--|----------------|
| Single Pedal Complete                      | <b>P3000D</b>  |
| Double Pedal Complete (right footed)       | <b>P3002D</b>  |
| Double Pedal Conversion Kit (right footed) | <b>P3001D</b>  |
| Double Pedal Complete (left footed)        | <b>P3002DL</b> |

ADJUSTABLE TRACTION PLATE

DUO-DECK FOOTBOARD

Demon Direct Drive (Shown in Shortboard Set Up) **P3000D**

# ELIMINATOR DEMON PEDALS

HEAVENLY FEEL... WICKEDLY FAST

## DEMON CHAIN

TRADITIONAL FEEL AND POWER OF A CHAIN

An innovative combination of Demon Drive speed and traditional chain drive feel, the Demon Chain's Perfect Circle cam delivers smooth, consistent response throughout the stroke for pinpoint accuracy and control. A high performance package for the driven power drummer.

PERFECT CIRCLE CAM

PIVOTING HOOP CLAMP

MULTI FUNCTION DRUM KEY

BEATER HEIGHT ADJUSTMENT

NiNJA BEARINGS

Demon Chain Drive  
(Shown in Longboard Set Up)  
**P3000C**



Chain Drive Double Pedal (Shown In Shortboard Setting)  
**P3002C**



**Z-LINK DRIVE SHAFT** Delivering the same precise action of the primary pedal in the secondary pedal, the Z-Link features hand assembled, CNC machined construction. Features Pearl's exclusive Zero Latency Universal Joints, and precision radial ball bearings.

Single Pedal Complete	<b>P3000C</b>
Double Pedal Complete (right footed)	<b>P3002C</b>
Double Pedal Conversion Kit (right footed)	<b>P3001C</b>
Double Pedal Complete (left footed)	<b>P3002CL</b>

**EQUIPMENT FAILURE IS NOT AN OPTION, END OF STORY.**

Pearl's hardware is LEGENDARY. Rugged, sure-footed, and built to last.

### P3000C DEMON CHAIN

DRIVE	Ultralight Chain
FOOT BOARD	Duo-Deck Convertible
DRIVE CAM	Perfect Circle "Linear Response" Cam
BEATER	Control Core
TENSION ADJUSTMENT	Click-Lock
DRIVE BEARINGS	NiNJA Low-Friction
PEDAL HEIGHT	Infinitely Adjustable



### PERFECT CIRCLE CAM

Its racing inspired lines transfer energy from your foot into the head with minimal mass and maximum speed.



### POWER CHAIN

This ultra lightweight, dual linkage Chain features low friction rollers for power and dependability.

# ELIMINATOR: REDLINE

The Key to Ultimate Bass Drum Performance



## ELIMINATOR REDLINE

### CHOOSE A CAM REDLINE YOUR PERFORMANCE

The world's only pedal featuring the Patented Interchangeable Cam System, Eliminator: Redline's virtually unlimited tunability lets you lock in personally tuned feel, power, and speed. Like having four pedals in one, Redline pushes the boundaries of bass drum performance by fusing the power and flexibility of Pearl's original Eliminator with the fluid speed of our Demon series pedals.

Eliminator: Redline  
Single Pedal, Chain Drive  
**P2050C**

#### CHAIN OR BELT DRIVE

\*Shown w/ Optional Red Cam



The sprocketless double chain drive on the Eliminator Redline (P2050C) provides super smooth action with powerful and precise feel. The Eliminator Belt Drive model (P2050B) provides a very comfortable, natural feel similar to a direct-drive system.

#### P2050C ELIMINATOR: REDLINE CHAIN

DRIVE	Sprocketless Double Chain
FOOT BOARD	Redline Reversible Traction Plate
DRIVE BEARINGS	NiNJA Low-Friction
BEATER	Control Core Quadbeater
TENSION ADJUSTMENT	Click-Lock
BEATER ANGLE	Uni-Lock Infinitely Adjustable
POWERSHIFTER	Three Position
CASE	Included
HEEL PLATE HINGE	Zero Play (U.S. Patent #7179978)

#### P2050B ELIMINATOR: REDLINE BELT

DRIVE	Belt-Reinforced Nylon Strap
FOOT BOARD	Redline Reversible Traction Plate
DRIVE BEARINGS	NiNJA Low-Friction
BEATER	Control Core Quadbeater
TENSION ADJUSTMENT	Click-Lock
BEATER ANGLE	Uni-Lock Infinitely Adjustable
POWERSHIFTER	Three Position
CASE	Included
HEEL PLATE HINGE	Zero Play (U.S. Patent #7179978)

**INTERCHANGEABLE CAM SYSTEM**

Provides a choice of 6 different color-coded cams (4 included and 2 more optional). Quickly changes the power and feel of the pedal to suit your individual playing needs. Changing the cam is as simple as pushing the release button and snapping another in place.

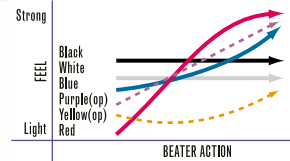

**BLACK CAMBK**  
Linear action cam



**WHITE CAMTWT**  
Oversized linear cam



**BLUE CAMTBL**  
Progressive cam



**RED CAMTRD**  
Radical progressive cam



**PURPLE CAMPL**  
Aggressive action cam  
(Optional)



**YELLOW CAMYL**  
Inverse action cam  
(Optional)

Eliminator: Redline  
Double Pedal, Belt Drive  
**P2052B**



Eliminator: Redline Double Pedal Chain Drive  
(Shown w/ Included Red Cam Attached)  
**P2052C**



Eliminator: Redline Series pedals come standard with Custom Carry bags.



**POWERSHIFTER FUNCTION** By moving the foot board forward or back, our revolutionary PowerShifter function provides 3 positions to fine tune the power and feel of the pedal. Instantly change the drive angle leverage to create a light, regular, or strong feel. *U.S. Patent #5574237*



**ZERO PLAY HINGE** Our proprietary stainless steel hinge provides maximum freedom of motion for blazing speed and prevents play between the footboard and heel. *U.S. Patent #7179978*



**NINJA BEARINGS** Developed by skateboarding engineers for the ultimate in fast, quiet performance, NiNJA Bearings incorporate state of the art micropolished steel balls for incredibly fast and smooth performance.



**ROLLER HOOP CLAMP** w/ Side Mount Adjustment. Quickly adapts to a wide range of hoop thicknesses for the smoothest, most secure grip possible. Easy side access to the hoop clamp makes set up and tear down a breeze.



**INDEPENDENT TRACTION GRIPS** Eliminator Redline's redesigned pedalboard features Pearl's exclusive reversible Traction Plate insert, allowing individual traction grip configuration to suit your exact playing requirements.



**THE CONTROL CORE QUADBEATER** Provides four beater surfaces (two hard plastic, two felt) with the added feel of the vibration-free Control Core elastomer center. *U.S. Patent #7626108*



**CLICK-LOCK SPRING ADJUSTMENT** w/ NEW Rotor Tension Cradle. Secures spring tension in high impact play. The counter spring adjustment's rolling cradle allows the spring to pivot with each stroke for less resistance. *U.S. Patent #7754953*



**UNI-LOCK BEATER ANGLE CAM** Grips the axle a full 360 degrees, allowing infinite beater angle adjustments. Floating Spring Pendulum design is perfectly centered on the clamp for full bearing movement and maximum smoothness.

# ELIMINATOR SOLO

*Singular Feel, Eliminator Speed, Priced to Perform. Fly Solo and Set Your Feet Free!*

## ELIMINATOR SOLO: BLACK

Delivering blinding speed and powerful performance, Eliminator Solo bass drum pedals put the fleet footed player in control with all the gliding velocity that made Pearl pedals revolutionary. These no nonsense, streamlined Eliminator models deliver singular, resistance free feel for effortless play and driving performance.

The Solo: Black pedal's even, slightly weighted feel delivers just the right amount of resistance without slowing your stroke - for increased power and less muscle fatigue.

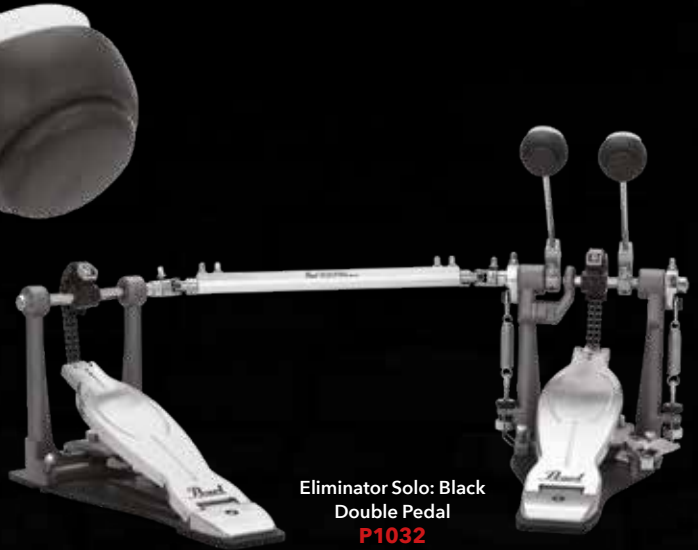

Eliminator Solo: Black  
Double Pedal  
**P1032**

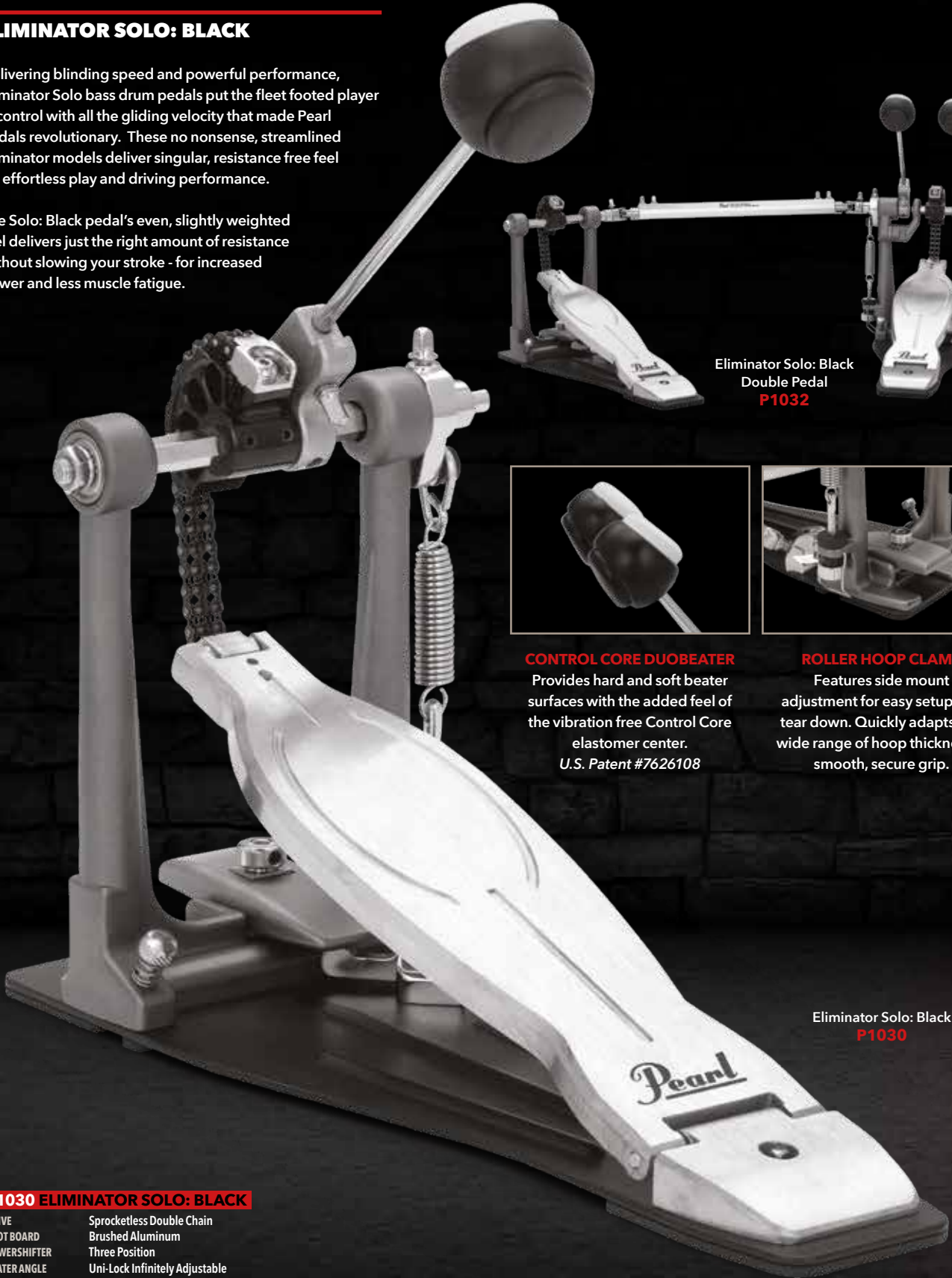

### CONTROL CORE DUOBEATER

Provides hard and soft beater surfaces with the added feel of the vibration free Control Core elastomer center.  
U.S. Patent #7626108



### ROLLER HOOP CLAMP

Features side mount adjustment for easy setup and tear down. Quickly adapts to a wide range of hoop thicknesses smooth, secure grip.

Eliminator Solo: Black  
**P1030**

### P1030 ELIMINATOR SOLO: BLACK

DRIVE	Sprocketless Double Chain
FOOT BOARD	Brushed Aluminum
POWERSHIFTER	Three Position
BEATER ANGLE	Uni-Lock Infinitely Adjustable
ROLLER HOOP CLAMP	Side Mount Adjustment
TENSION ADJUSTMENT	Click-Lock
BEATER	Control Core DuoBeater

# ELIMINATOR

## P1030R ELIMINATOR SOLO: RED

DRIVE	Sprocketless Double Chain
FOOT BOARD	Brushed Aluminum
POWERSHIFTER	Three Position
BEATER ANGLE	Uni-Lock Infinitely Adjustable
ROLLER HOOP CLAMP	Side Mount Adjustment
TENSION ADJUSTMENT	Click-Lock
BEATER	Control Core QuadBeater

## ELIMINATOR SOLO: RED

Delivering accurate speed and focused performance, the Eliminator Solo: Red bass drum pedal delivers no-nonsense Eliminator feel for the technically decisive player.

Focusing the drive on the accurate feel of the Radical Progressive Action of Eliminator: Redline Red Cam, its shape allows the double chain to better match the motion of your foot. This means smooth movement at the bottom of the stroke with an accelerated PUSH at the top, and quick rebound for reactive doubles.

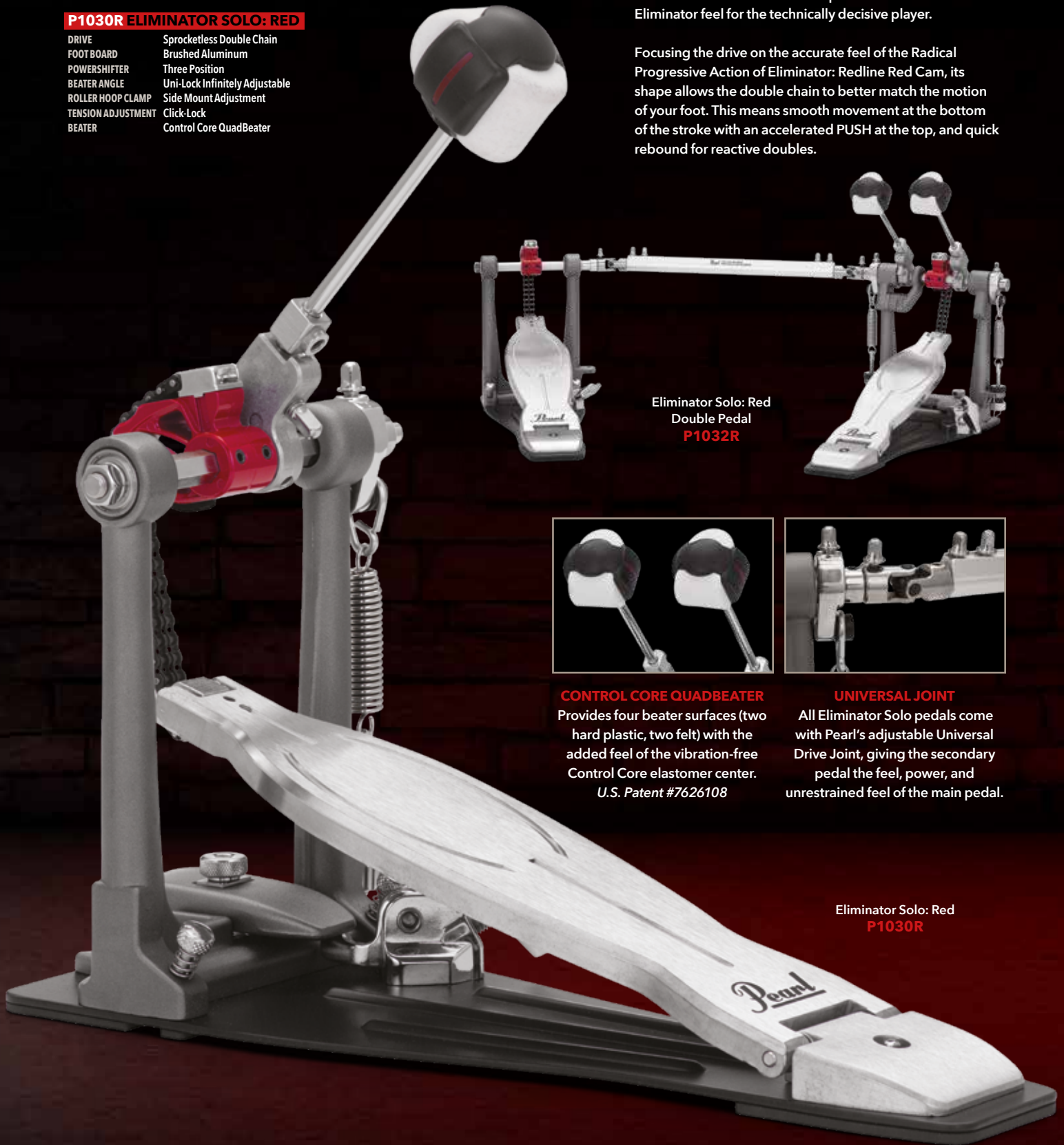

Eliminator Solo: Red  
Double Pedal  
P1032R



### CONTROL CORE QUADBEATER

Provides four beater surfaces (two hard plastic, two felt) with the added feel of the vibration-free Control Core elastomer center.  
U.S. Patent #7626108



### UNIVERSAL JOINT

All Eliminator Solo pedals come with Pearl's adjustable Universal Drive Joint, giving the secondary pedal the feel, power, and unrestrained feel of the main pedal.

Eliminator Solo: Red  
P1030R

# P930/P932 PEDALS

Speed and Control for the Masses

## SUPER SMOOTH, EXTREMELY FAST!

Merging quick rebound response of our flagship Demon Drive with the finely-tuned control of our award-winning Eliminator models, the P930 bass drum pedal offers high end performance at a player accessible price. Its longboard playing deck delivers a lighter feel for increased speed, and offers advanced performance control and tunability with two rotor cam options. The ultimate pedal for fast feet on a budget.

### P930 BASS DRUM PEDAL

DRIVE Single Chain Drive  
 DRIVE CAM Perfect Circle Cam w/  
 Removable Eliminator-  
 style Progressive Cam  
 FOOTBOARD Demon Style Long Board  
 BEATER Control Core DuoBeater  
 BEATER ANGLE Infinitely Adjustable  
 SPRING TENSION Click-Lock

### P932 DOUBLE BASS DRUM PEDAL

DRIVE Single Chain Drive  
 DRIVE CAM Perfect Circle Cam w/  
 Removable Eliminator-  
 style Progressive Cam  
 FOOTBOARD Demon Style Long Board  
 BEATER Control Core DuoBeater  
 BEATER ANGLE Infinitely Adjustable  
 UNIVERSAL JOINT Length and Position Adjustable

- Single Pedal Complete **P930**
- Double Pedal Complete (right footed) **P932**
- Double Pedal Conversion Kit (right footed) **P931**
- Double Pedal Complete (left footed) **P932L**



The P930 pedal is included as an upgrade in the 830 Series hardware pack and comes with Export and Export Lacquer drum sets.

Single Pedal Complete  
**P930**

2 POSITION  
 POWERSHIFTER  
 FUNCTION



CONTROL CORE  
 DUO BEATER

BEATER HEIGHT  
 ADJUSTMENT

INTERCHANGEABLE  
 CAM TECHNOLOGY

INFINITE BEATER  
 ANGLE ADJUSTMENT



Comes standard with Perfect Circle and removable Orange Progressive Cams, for fully tunable performance and increased control.

CLICK LOCK  
 SPRING TENSION



CLICK-LOCK SPRING TENSION maintains perfect tension gig after gig. Set it and forget it. (U.S. Patent #7754953)





**ORANGE PROGRESSIVE CAM**  
can be removed to reveal the Perfect Circle for further tunability to match your playing style. (U.S. Patent #6172291)

**CONTROL CORE DUO BEATER**  
(U.S. Patent #7626108) utilizes an elastomer center to minimize vibration and features two unique playing surfaces (rounded felt and convex hard plastic surface) for quick-shifting tone and feel.

**POWERSHIFTER FUNCTION**  
(U.S. Patent #5574237) further tunes the power, feel, and leverage of the pedal by shifting the chain angle forward for lighter feel, or back for increased power.



**P932 DOUBLE PEDAL COMPLETE**  
Double the speed, power and control with the P932 Double. Give your feet the gift of speed at a fraction of the cost of other "less innovative" pedals.

Double Pedal Complete  
**P932**

## Speed, Power, and Value **P530 / P830**



**P530**  
DRIVE Sprocketless Double Chain  
DRIVE CAM Round/Linear Action  
FOOTBOARD Standard Length  
BEATER DuoBeat Two-Surface (Hard Plastic/Felt.)  
HOOP CLAMP Side Tension

Single Pedal Complete  
**P530**

### **P530 DRUM PEDAL**

With all the speed and function of a pro bass drum pedal at half the price, Pearl's P530 Bass Drum Pedal features a dual chain and Linear Action cam drive for smooth, traditional pedal action and speed. The radius rod frame makes it highly portable for gigging, while features like a two surface DuoBeater and rotor tension axle clamp make it adaptable to virtually any feel or playing style.

**P830**  
DRIVE Single Chain  
DRIVE CAM Perfect Circle  
FOOTBOARD Demon Style Longboard  
BEATER DuoBeat Two-Surface  
BEATER ANGLE Infinite Angling  
SPRING ROLLER Nylon

Single Pedal Complete  
**P830**

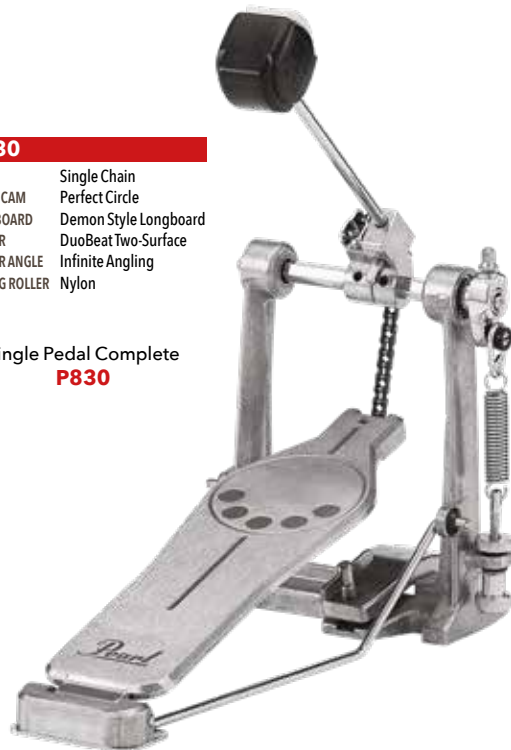

### **P830 DRUM PEDAL**

Light in weight but not in features, the P830's Demon-style longboard increases playing surface for maximum leverage and speed. Its fully adjustable beater angle, Perfect Circle single chain cam, and DuoBeat two-surface beater deliver customizable feel for the player on the move.

# HI-HAT STANDS

Biggest Advancement In Time-Keeping  
Since The Wristwatch

H2050

Sharing many of the key characteristics of Pearl's Eliminator Redline bass drum pedals, 2050 Series Hi-Hat Stands deliver unparalleled versatility and customization in hi-hat pedal control. The world's-only hi-hat stand featuring the Interchangeable Cam System, 2050 Series stands' customizable options are designed to eliminate resistance, reduce fatigue, and increase performance.

“Night in and night out, Pearl hardware keeps everything right where it should be, and without fail!”  
- OKWA ANDREWS

BRIAN FRASIER-MOORE  
Justin Timberlake / Pink

OKWA ANDREWS  
Brian's Tech

Pearl's Rapid Lock Super Grip's slip-proof clutch system features a patented 360° lock nut that provides vice-like clamping force for a super grip.  
(U.S. Patent #9355625)

H2050



RH2050

The RH2050 Remote Hi-Hat's low-friction cable produces smooth, lag-free performance with the lightning-fast action of the PosiLink Twin Cam drive system. Fast, natural-feeling cymbal play is finally accessible virtually anywhere on the kit, or to facilitate multiple hi-hat system setups.



H1050



## H2050

Rapid Lock Super Grip Clutch (U.S. Patent #9355625)  
Hi-Hat Cup (U.S. Patent #7078606)  
Swiveling Legs  
Precision Spring Tension Dial  
PosiLink Twin Cam Drive System with Interchangeable Cams  
Traction Plate Footboard Convertible Spike/Rubber Feet  
(U.S. Patent #7371953)  
Footboard Docking Station  
PowerShifter  
Height Range of 750 - 1030mm

## RH2050

Rapid Lock Clutch (U.S. Patent #9355625)  
Direct Pull Drive System  
Infinitely Adjustable Footboard Angle  
Double Braced Tripod w/ Swivel Function  
Spike/Rubber Tips  
Spring Tension Dial  
Hi-Hat Cup (U.S. Patent #7078606)

## H1050

Rapid Lock Clutch (U.S. Patent #9355625)  
Direct Pull Drive System  
Infinitely Adjustable Footboard Angle  
Double Braced Tripod w/ Swivel Function  
Spike/Rubber Tips  
Spring Tension Dial  
Hi-Hat Cup (U.S. Patent #7078606)  
Height range of 700 - 960mm



**INDEPENDENT TRACTION GRIPS** Features Pearl's exclusive reversible Traction Plate and individual traction grips, configurable to suit your individual taste.



**H2050 PRECISION SPRING TENSION DIAL** Allows perfect tension control for fine-tuned response.



**H1050 PEDAL HEIGHT ADJUSTMENT** The infinite footboard angle adjustment featured on the H2050 and H1050 allows precise height matching in multi-pedal setups.



**CLAMSHELL CLAMP** The H2050, H1050, H1030, H1030S, and H930 Hi-Hat Stand uses beefy 1" tubing and clamshell clamps with built-in memory locks for superior rigidity.



**CLA130**  
 Closed Hi-Hat  
 Bass Drum Hoop Mounted  
 Side-to-Side,  
 Forward/Back Adjustable  
 Ultragrip Wingnut  
 Spring Adjustable  
 Cymbal Spread



**CLH930**  
 Closed Hi-Hat  
 Uni-Lock Tilter  
 Knurled Boom Arm  
 UltraGrip Wing Nuts  
 / Wing Bolts



**CLH70**  
 Closed Hi-Hat  
 Multi-Angle Quickset Clamp  
 Gearless UniLock Tilter  
 Ultragrip Wingnut  
 Spring Adjustable Wash

Features Eliminator Solo traditional footboard, double braced swiveling tripod, and gigging weight tubing for touring professionals.

Features Eliminator Solo traditional footboard, single braced swiveling tripod, and reduced weight for gigging professionals.

Features an independent tripod positioned separately from the pedal frame, making it the only flat based hi-hat stand specifically for double pedals.



<p><b>H1030</b>          Direct Pull Drive System          Precision Spring Tension Dial          Double Braced Tripod w/ Swivel Function          SureGrip Oversize Rubber Feet          Smooth Traditional Footboard          Height range of 760 - 940mm</p>	<p><b>H1030S</b>          Direct Pull Drive System          Precision Spring Tension Dial          Single Braced Tripod w/ Swivel Function          Smooth Traditional Footboard          Height range of 760 - 940mm</p>	<p><b>H930</b>          Direct Pull Drive System          Precision Spring Tension Dial          Double Braced Tripod w/ Swivel Function          SureGrip Oversize Rubber Feet          Demon Style Long Board Footboard          Height range of 760 - 940mm</p>	<p><b>H830</b>          Demon Style Long Footboard          (Single Color Footboard)          Double Braced Tripod w/ Swivel Function          Height range of 610 - 910mm</p>	<p><b>H150S</b>          Light Weight (6.30 lbs.)          Stable Flat-Based Tripod          Swivel Function Allows Easy          Double-Pedal Positioning          Direct-Pull Drive System          Spring Tension Adjustment          Redline Traction Plate Footboard          Height range of 745 - 865mm</p>
---	---	--	--	--



**HA130**

**HA130** Positions your hi-hat next to your bass pedal in double bass set-ups for effortless transitions between pedals.



**H930 HI-HAT STAND**  
 H930 Hi-Hat Stand features our Demon style longboard, double braced tripod w/ swivel function, and precision tension dial.



**H830 HI-HAT STAND H830**  
 Hi-Hat Stand is standard equipment with our Export series and offers a monochromatic Demon Style longboard design and swivel tripod.



\*Toe Stopper Not Included

**H150S\* FLAT-BASED SWIVELING HI-HAT** The H150S independent tripod is positioned separately from the pedal frame making it the only flat-based hi-hat stand with swiveling legs.

# SNARE STANDS

Every Snare Should Be So Lucky

No matter the gig or the drum, Pearl has a stand to accommodate both with security, high function, and chameleon-like diversity.



**S1030**



**S1030D**



**S930**



**S1030**

GyroLock Tilter: Infinite Angle Adjustability  
Adjustable Snare Basket: Fits Snares 10" - 16"  
Air Suspension Rubber Tips  
Trident Tripod  
Height Range of 480 - 700mm  
Oversize Super Grip Rubber Feet

**S1030D**

Low Position Snare Stand (Height Range: 310 - 520mm)  
GyroLock Tilter: Infinite angle adjustability  
Adjustable Snare Basket: Fits 10" to 16" drums  
Air Suspension Rubber Tips  
Trident Tripod  
Oversize Super Grip Rubber Feet

**S930**

Uni-Lock Tilter  
Air Suspension Rubber Tips  
Double Braced Trident Style Tripod  
Fits Snares 10" - 14"  
Height Range of 470 - 670mm  
**S930S** drop basket version also available



**S1030 SNARE STAND**  
**GYROLOCK** Our premier S1030 model features Pearl's 360 degree infinitely adjustable GyroLock tilter for ease-of-use and pinpoint positioning.



**S1030 SNARE BASKET** The Pearl S1030 Snare Stand adjusts to fit virtually any size snare from 10" to 16". The Air Suspension rubber tips securely cradle your prized snares while allowing them to fully resonate.



**S930D SNARE BASKET** The S930D Snare Stand is a shorter version of the S930 Snare Stand, and is built to comfortably accommodate deeper snare drums.



**SPIKED / RUBBER FEET** (Sold Separately)  
Our CVT300/3 Push Button Spiked/Rubber Feet come in pack of 3 to retrofit on any of our 1030 Series hardware for sure-footed performance on any terrain. (U.S. Patent #7371953)

**S930D**



**S930S**



**S830**



**S150S**



S150S Convertible Tripod Base

**S930D**

Uni-Lock Tilter  
Air Suspension Rubber Tips  
Double Braced Trident Style Tripod  
Fits Snares 10" - 14"  
Height Range of 360 - 570mm

Drop basket for deeper snares

**S930S**

Uni-Lock Tilter  
Air Suspension Rubber Tips  
Single Braced Trident Style Tripod  
Fits Snares 10" - 14"  
Height Range of 420 - 610mm

**S830**

Uni-Lock Tilter  
Double Braced Tripod  
Fits Snares 13" - 14"  
Height Range of 440 - 650mm

Standard with Export Series drums, perfect for local gigging and easy transport

**S150S**

Light Weight (5.18 lbs.)  
Stable Flat-Based Tripod  
Gearless Uni-Lock Basket Tilter  
Convertible Tripod or Flat-Based Legs

Instantly convertible from flush-based to standard tripod

# DRUM THRONES

Sound Ergonomics

**MULTI-CORE FOAM TECHNOLOGY:** Roadster thrones now feature multiple layers of varied density foam which combine for a better playing foundation and improved feel.

**D3500BR**



**D3500**



**D1500TGL**



**D1500RGL**



**D3500BR**

Saddle-Style, Multi-Core Foam Cushion  
Detachable Backrest Mounts via Single Knob  
Lock/Spin System: Reversible StopLock  
allows cushion to be secured in place or free spinning depending on preference  
Height Range of 495-665mm

**D3500**

Saddle-Style, Multi-Core Foam Cushion  
Accepts Optional Backrest  
Lock/Spin Reversible StopLock System  
Height Range of 495 - 665mm

**D1500TGL**

15" Trilateral Multi-Core Foam Cushion  
Option of a Saddle or Round top feel  
Accepts Optional Backrest  
Gas Lift Height Adjustment  
Lightweight Aluminum Struts:  
Solid support with easier transport  
Height Range of 495 - 695mm

**D1500RGL**

15" Round Multi-Core Foam Cushion  
Accepts Optional Backrest  
Gas Lift Height Adjustment  
Lightweight Aluminum Struts  
Height Range 495 - 695mm

**D1500SP**



**D1500**



**D1500S**



**DTBR1535**



**D1500SP**

15" Vented Round Seat  
Multi-Core Foam Donut Cushion  
Accepts Optional Backrest  
Built-In Shock Absorber Post  
w/ Adjustable Spring Tension  
Lock/Spin Reversible StopLock System  
Height Range of 525 - 630mm

**D1500**

15" Vented Round Seat  
Multi-Core Foam Donut Cushion  
Accepts Optional Backrest  
Lock/Spin Reversible StopLock System  
Height Range 495 - 665mm

**D1500S**

15" Vented Round Seat  
Multi-Core Foam Donut Cushion  
Accepts Optional Backrest  
Lock/Spin Reversible StopLock System  
Height Range 445 - 615mm

**DTBR1535**

12.5" x 7" Optional Backrest  
Formfitting and Breathable  
Removable  
Dual Axis Adjustability

**D930**



**D790**



**D730S**



**D50**



**D930**

Round Vinyl Cushion  
Double Braced Legs  
Height Range of 470 - 660mm

**D790**

Round Vinyl Cushion  
Double Braced Legs  
Height Range of 430 - 650mm

**D730S**

Round Vinyl Cushion  
Single Braced Tripod  
Height Range of 405 - 605mm

**D50**

Round Vinyl Cushion  
Double Braced Tripod  
Height Range of 495 - 620mm

# CYMBAL STANDS

Welcome to Boom Town

**FOR EVERY CYMBAL, THERE IS A PLACE.**

Advancing Drum Hardware for Serious Working Drummers since 1946. Through constant setup, teardown, performance, practice, and transport, Pearl has you covered with cymbal stand solutions that are ready to endure constant abuse and keep going.

“ Pearl hardware is literally the only hardware that you’ll ever have to buy! ”  
- TRACY BROUSSARD

TRACY BROUSSARD  
Blake Shelton

The most technically advanced boom stand ever devised. Perfect for studio or live applications.

**BC2030**

Reversible Felt/  
Foam Washer.



**BC2030**

GyroLock Tilter  
WingLoc  
Reversible Cup Washer w/ O-ring  
Die Cast Joint w/ Stop Lock  
Trident Tripod  
Double Braced Legs  
Built in Percussion Post  
Nodal Point Resonance Enhancing System  
Height Range of 800 - 2150mm

**B1030C**



**B1030C**

GyroLock Tilter  
WingLoc  
Reversible Cup Washer w/ O-ring  
Convertible Boom Tilter  
Trident Tripod  
Double Braced Legs  
Reversible Felt/ Foam Washer  
Height Range of 820 - 1900mm

**B1030**



**B1030**

GyroLock Tilter  
WingLoc  
Reversible Cup Washer w/ O-ring  
Die Cast Joint  
Trident Tripod  
Double Braced Legs  
Built in Percussion Post  
Reversible Felt/Foam Washer  
Height Range of 820 - 1900mm

**BC930**



**BC930**

Uni-Lock Tilter  
Plastic Wingnut  
Plastic Cymbal Cup  
Die Cast Joint  
Trident Style Tripod  
Convertible Boom Tilter  
Double Braced Leg  
Height Range of 830 - 1800mm

Reduced weight for easy gigging transport.

**BC930S**



**BC930S**

Uni-Lock Tilter  
Plastic Wingnut  
Plastic Cymbal Cup  
Die Cast Joint  
Trident Tripod w/ Single Braced Legs  
Convertible Boom Tilter  
Height Range of 780 - 1800mm

Offers lighter weight with advanced appointment designs.

**BC830**



**BC830**

Uni-Lock Tilter  
Plastic Wingnut  
Plastic Cymbal Cup  
Die Cast Joint  
Convertible Boom Tilter  
Double Braced Legs  
Height Range of 780 - 1480mm

**BC820**



**BC820**

Uni-Lock Tilter  
2 Section Stand  
Plastic Wingnut  
Plastic Cymbal Cup  
Die Cast Joint  
Convertible Boom Tilter  
Double Braced Legs  
Height Range of 900 - 1740mm

**BC150S**

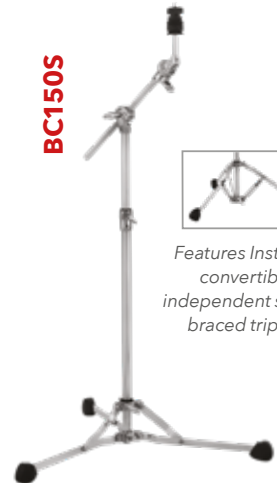

Features Instantly convertible independent single-braced tripod.

**BC150S**

Light Weight (5.42 lbs.)  
Uni-Lock Tilter  
Convertible Single-Braced Tripod  
Convertible Boom Tilter  
Plastic Wingnut and Cymbal Cup  
Reversible Felt/Foam Washer  
Height Range of 780 - 1300mm



**CLAMSHELL**

designed Die Cast joint on 2030, 1030, 930 series Boom and Straight cymbal stands, provides superhuman clamping force. Set your position, lock it down and wail away.



**830 SERIES STANDS**

offer lighter weight while incorporating many of the 1030 series designs. The tripod uses Trident style design with double braced legs. Large easy to use wingnuts and lateral struts for optimal stability.

Solid. Stable. Professional.

Exceptional stability for gigging and touring.

Built for rigid support and light transport.

Offers lighter weight with advanced appointment designs.

Features Instantly convertible independent single-braced tripod.



C1030	C930	C930S	C830	C150S
GyroLock Tilter WingLoc Reversible Cup Washer w/ O-ring Die Cast Joint Trident Tripod Double Braced Legs Height Range of 770 - 1530mm	Uni-Lock Tilter Plastic Wingnut Plastic Cymbal Cup Die Cast Joint Trident Style Tripod Double Braced Legs Height Range of 760 - 1500mm	Uni-Lock Tilter Plastic Wingnut Plastic Cymbal Cup Die Cast Joint Trident Tripod w/ Single Braced Legs Height Range of 780 - 1480mm	Uni-Lock Tilter Plastic Wingnut Plastic Cymbal Cup Die Cast Joint Double Braced Legs Height Range of 720 - 1480mm	Light Weight (4.80 lbs.) Uni-Lock Tilter Convertible Single-Braced Tripod Plastic Wingnut and Cymbal Cup Reversible Felt/Foam Washer Height Range of 670 - 1350mm



**REVERSIBLE FELT / FOAM CYMBAL WASHERS** allow four-way control of cymbal "ring" by mixing and matching the "hard" and "soft" surfaces of the washers.

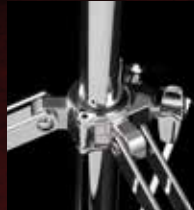

**THE TRIDENT TRIPOD** uses a full 360° of clamping force via the hinged collar. The inner tube rests in a nylon bushing to prevent metal to metal contact. Heavy duty legs feature lateral bracing for superior ultra quiet rigidity.



**REVERSIBLE CUP WASHER w/ O-RING (U.S. Patent #6940006)** Specially designed to "float" normally or "lock" to prevent noise during recording.



**WINGLOC** Quick Release Wing Nut (U.S. Patent #6884015) Secure, adjustable, spring loaded cymbal nuts for quick set up and tear down.



**NODAL POINT MARKINGS** Pearl's BC2030 features markings on the telescopic tubes that allow cymbals to achieve better clarity and sustain when the tubes are positioned at their respective Nodal Points. (U.S. Patent #9070348)



**GYROLOCK TILTERS** are infinitely adjustable and provide 360 degree range of motion for precise positioning with one-step convenience.

# ICON RACK SYSTEM

The Original Drum Rack, Expanded



EXPORT LACQUER  
#222 Gloss Tobacco Burst



Developed in 1983 with legendary Toto drummer Jeff Porcaro, Pearl's original DR1 Drum Rack was the first freestanding, frame based drum support system available.

Now, Pearl expands the **ICON** (short for **I**ndependent **CON**trol) Rack system with a fresh selection of upgrades and high function mounting options.

3-Sided Rack  
(\*also available DR008 Expansion Bar)  
**DR80**

<b>DR80</b>	
INCLUDES	(4) PC8 Pipe Clamps
RACK BAR	Black Anodized Aluminum 38mm Square, 91cm Length
RACK LEG	Black Anodized Aluminum 1.5" Diameter, 70.5cm Height



Single Drum Rack, Straight  
(w/ PCX100X2 & PCL100X2)  
**DR511**

<b>DR511</b>	
MAIN SUPPORT RAIL	Brushed Aluminum, 40mm Square
MOUNTING CLAMPS	PCX100 Clamps (x2) Fits 1/2" to 1 1/8"
RACK RAIL LENGTH	38" (From Center of Right to Left Clamp) 36" (Usable Area)
RACK PIPE/LEG	Steel 1.5" / 3.8cm Diameter, 34" / 86.5cm Height
SUPPORT FOOT	Rotating 1.5" Round w/ TLJ200 T-Clamp (P38475TA)
PIPE CLAMPS	PCL100 (x2) Accepts 7/8" Diameter Arms



Single Drum Rack, Curved  
(w/ PCX100X2 & PCL100X2)  
**DR511C**

<b>DR511C</b>	
MAIN SUPPORT RAIL	Brushed Aluminum, 40mm Square
MOUNTING CLAMPS	PCX100 Clamps (x2) Fits 1/2" to 1 1/8"
RACK RAIL LENGTH	46" (From Center of Right to Left Clamp / 44" (Usable Area)
RACK PIPE/LEG	Steel 1.5" / 3.8cm Diameter, 34" / 86.5cm Height
SUPPORT FOOT	Rotating 1.5" Round w/ TLJ200 T-Clamp (P38475TA)
PIPE CLAMPS	PCL100 (x2) Accepts 7/8" Diameter Arms



**RACKS** Preconfigured single and three-sided rack packages with rotating support feet.



**MASTERWORKS SERIES STUDIO SHELL RECIPE**  
in Gloss Natural Artisan Sycamore with Ebony inlay & Black Nickel Hardware



**MASTERWORKS SERIES with ICON RACK & e/MERGE**  
in Black Sparkle Burst to Granite Sparkle & Black Nickel Hardware



Three-Sided  
Drum Rack, Straight  
(w/ PCX100X4 & PCL100X2)  
**DR513**

**DR513**

RACK RAILS Pearl 40mm Square Anodized Aluminum  
SUPPORT LEGS/FEET 38"x2.5" Round Chrome w/ P38475TA Rotating Foot  
INCLUDED RAIL CLAMPS 4 PCX100  
INCLUDED PIPE CLAMPS 2 PCL100  
USABLE RAIL AREA 36" (38" from Center of Right to Left Clamp)



Three-Sided  
Drum Rack, Curved  
(w/ PCX100X4 & PCL100X2)  
**DR513C**

**DR513C**

RACK RAILS Pearl 40mm Square Anodized Aluminum  
SUPPORT LEGS/FEET 38"x2.5" Round Chrome w/ P38475TA Rotating Foot  
INCLUDED RAIL CLAMPS 4 PCX100  
INCLUDED PIPE CLAMPS 2 PCL100  
USABLE RAIL AREA 36" (38" from Center of Right to Left Clamp)



Straight Drum Rack Expansion Bar  
w/ Support Leg  
**DR511E**

**DR511E**

RACK RAIL Pearl 40mm Square Anodized Aluminium  
SUPPORT LEG/FOOT 34"x2.5" Round Chrome w/ P38475TA Rotating Foot  
USABLE RAIL AREA 36" (38" From Center of Right to Left Clamp)



Curved Drum Rack Expansion Bar  
w/ Support Leg  
**DR511CE**

**DR511CE**

RACK RAIL Pearl 40mm Square Anodized Aluminium  
SUPPORT LEG/FOOT 34"x2.5" Round Chrome w/ P38475TA Rotating Foot  
USABLE RAIL AREA 44" (46" From Center of Right to Left Clamp)



Drum Rack Moveable  
Support T-Leg  
**DR110T**

**DR110T**

SUPPORT LEG/FOOT 34"x2.5" Round Chrome w/ P38475TA Rotating Foot

# RACK ACCESSORIES

An Industry Icon - The Professional's Choice

## ICON RACK RECIPES

Check out Pearl's ICON Rack Recipe videos at [www.pearlrackrecipes.com](http://www.pearlrackrecipes.com) for step-by-step instructions on how to get the most from existing and available Pearl Rack parts.

## MOUNTING CLAMPS

Developed for the slip resistant ICON square rack rail and round support pipe. Each dramatically increases the level of setup flexibility and function variety.



Expandable Pipe Clamp  
Fits All Icon Rack Leg Posts  
**PCL100**



Dual Pipe Clamp  
**PCR100**



Pipe To Rail Clamp  
**PCR200**



Pipe To Rail Clamp  
**PCR200L**



Rotating Pipe Accessory Clamp  
**PCR50X**



Pipe Accessory Clamp  
**PCR50L**



Rotating Dual Pipe Clamp  
**PCR50R**



Curved Rack Rail  
Short w/ Clamp  
**AL86AC**



Curved Rack Rail  
Medium w/ End Caps  
**AL103A**



Icon Support Foot  
w/ TLJ200 T-Clamp  
**P38475TA**



Rail Accessory Clamp  
Clamp System  
w/ Adjustable Jaw  
**PCX100**



Rotating Rail Accessory  
Clamp Tilting Clamp  
System w/ Adjustable Jaw  
**PCX200**



Extended Rotating  
Rail Accessory Clamp  
**PCX300**



Pipe Clamp  
Fits 7/8" tubes, for DR80  
**PC8**



Icon  
6" Mini-Expansion Bar  
**RJ50**



Pipe Joint  
**RJ100**

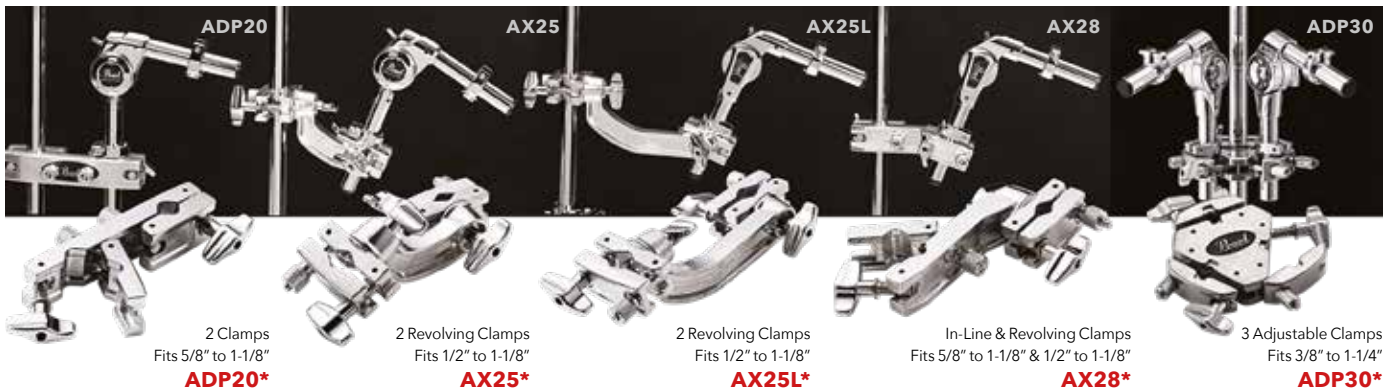

2 Clamps  
Fits 5/8" to 1-1/8"  
**ADP20\***

2 Revolving Clamps  
Fits 1/2" to 1-1/8"  
**AX25\***

2 Revolving Clamps  
Fits 1/2" to 1-1/8"  
**AX25L\***

In-Line & Revolving Clamps  
Fits 5/8" to 1-1/8" & 1/2" to 1-1/8"  
**AX28\***

3 Adjustable Clamps  
Fits 3/8" to 1-1/4"  
**ADP30\***

# TOM STANDS/ARMS

*Positioning Possibilities  
Never Before Attainable*

Our T/TC1030 Series features our GyroLock tilter for an infinite 360 degree range of movement. The T/TC930 Series use our Uni-Lock tilter for 180 degrees of motion. Our TH88 and TH70 Tom Arms Series use our dependable gear tilter.



**GYROLOCK**



**UNI-LOCK**



**GEAR TILTER**



**T1030**



**T930**



**TC1030B**



**TC930**



**CHB75CA**



**CHB75LB**



**CH1030B**



**CH930**



**CH830**



**Mic Holder**  
**MH830**



**TH1030**



**TH1030S**



**TH1030I**



**TH900S**



**TH900I**



**UX80S**

Features rotating infinitely adjustable clamps for multiple uses.



**TX100**  
13" Tube Height Extender

Accepts 7/8" dia. tubes. Ideal for extending snare stand height.



**TX125**  
Tube Extender for 1" Pipe

Accepts 1" dia. tubes. Ideal for extending travel conga stands.



**Chrome Multi Bass Drum Legs**  
**PMBDL3/C**

Multi-Bass Drum Legs allow any bass drum to be played horizontally. Height and tilt adjustable.



**CH1030BS**



**CH930S**



**CH830S**



**Boomerang Curved Boom Arm with Clamp and Tilter**  
**CHC200**

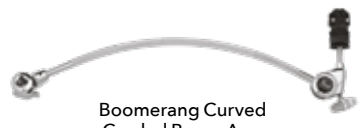

**Boomerang Curved Cymbal Boom Arm**  
**CHC100**



**Two Way Arm Clamp**  
**DCA180**



**Arm & Leg Cymbal Adapter (shown w/ DC180)**  
**CHA70**



**Boom Arm Cymbal Holder**  
**CH70**



**Mic Holder**  
**MH70A**



**Bass Drum Mount Cymbal Holder**  
**CHB830**

Mounts directly to the bass drum.

# PEARL PERCUSSION ARTISTS



**AARON DRAPER**  
John Mayer / Eminem / Adele



**ALAIN PEREZ**  
Alain Perez



**ANDY FARAG**  
Umpheys McGee



**ARCHIE PENA**  
Shakira



**BOBBY ALLENDE**  
Tito Nieves



**BRETT BAKER**  
Rihanna / Jay-Z



**CAMILO QUINONES**  
El Dusty



**CARLITO SOTO**  
Willie Colon



**CARLITOS PADRON**  
Rumberos Del Callejon



**CESAR ESPINOZA**  
Orchestra Tobacco Y Ron



**COLIN DOUGLAS**  
Aerosmith



**CHRISTIAN PEPIN**  
Independent



**DIMAS SANCHEZ**  
Fusion Beat / Trilogy Latin Jazz



**DOMINIQUE THOMAS**  
John Legend / Jill Scott



**EMRAH KOTAN**  
Independent



**ETIENNE FUENTES**  
Independent



**HORACIO HERNANDEZ**  
Independent



**JESSIE CARABALLO**  
Marc Anthony



**JESUS DIAZ**  
Independent



**JOSE ROSA**  
Independent



**LALO DAVILA**  
MTSU



**MARC QUIÑONES**  
The Doobie Brothers



**MARCO "ITO" ARGUINZONI**  
Independent



**MARVIN DIZ**  
Independent



**OG**  
Slightly Stoopid



**OMAR LEDEZMA**  
Independent



**PAPO PEPIN**  
N.Y. Conga Legend



**RAFA PERIEIRA**  
Janelle Monae



**RAVI JAKHOTIA**  
Ravi Drum



**ROBERTO VIZCAINO JR.**  
Orquesta Akokan



**ROLANDO MORALES MATOS**  
The Lion King / Curtis Institute



**SAMMY FIGUEROA**  
Master Percussionist



**SAMMY GARCIA**  
Independent



**TRILOK GURTU**  
Independent



**VALERIE DEE NARANJO**  
Saturday Night Live Band



**ZIG WALJER**  
Hands-On With Zig

# SIGNATURE SERIES

The Pros Play Pearl!

## BOBBY ALLENDE

### FIBERGLASS CONGAS AND BONGOS

Bobby Allende is a mainstay in the New York Latin Music Scene and he demands the best from his drums, that's why he plays Pearl. His Signature drums are fiberglass with no seams to inhibit vibration which allow the drums to resonate freely for the full, rich sound that Bobby is famous for. The congas are 28 inches tall, fitting the traditional seated player perfectly while adding extra width to the base for added projection and stability. A matching set of bongos is also available.



#617 Confetti  
Signature Fiberglass  
Congas and Bongos



<b>SHELL</b>	Seamless Fiberglass
<b>HEADS</b>	Remo Fiberskyn3
<b>RIMS</b>	Low-Rider Contour Crown
<b>HARDWARE</b>	Brushed Steel
<b>FINISH</b>	#617 Confetti
<b>BONGOS</b>	PBF300DXBA
<b>OPTIONAL BAGS</b>	PSC110CG 11" Quinto Conga Bag PSC117CGW 11.75" Conga Bag PSC125CG 12.5" Tumba Conga Bag

The Bobby Allende congas and bongos feature Remo Fiberskyn 3 heads for tuning stability and Pearl's Low-Rider crowns with a radical sloping edge that practically disappears under your hands for comfort you have to experience to believe.

If you demand excellence like Bobby, check out his Signature Fiberglass Congas and Bongos.

<b>CONGAS</b>	
<b>PCF110DXBA617</b>	11" QUINTO
<b>PCF117DXBA617</b>	11.75" CONGA
<b>PCF125DXBA617</b>	12.5" TUMBA

<b>BONGOS</b>	
<b>PBF300DXBA617</b>	7" & 8.5"

## JESUS DIAZ

### OAK CONGAS AND BONGOS

Cuban born Jesus Diaz is one of the most in demand percussionists and vocalists on the scene today. His active schedule provided the feature set for his signature series of congas and bongos. Designed for the seated player the Thai Oak drums measure 30" tall and from the Quinto to Tumba feature added girth to the belly of the drum. Seated conga players typically have to tilt the drum to achieve the desired projection, but the Jesus Diaz drums feature a 4" port on the front of the drum that is strategically positioned to deliver the maximum base frequency while the drum remains flat on the floor.



PHOTO: LISA KEATIN



#580 Brushed Platinum  
Natural Buffalo Skin Heads

<b>SHELL</b>	Thai Oak
<b>HEADS</b>	Buffalo Skin
<b>RIMS</b>	Low-Rider Contour Crown
<b>HARDWARE</b>	Quick Release Lugs Brushed Steel Finish
<b>FINISH</b>	#580 Brushed Platinum
<b>BONGOS</b>	PBW300DXJD
<b>OPTIONAL BAGS</b>	PSC110CG 11" Quinto Conga Bag PSC117CGW 11.75" Conga Bag PSC125CG 12.5" Tumba Conga Bag

The drums also feature a newly designed Quick Release lug that is slotted to allow removal of the tension rod without fully removing the nut. Player comfort was also an important ingredient in the design of the hoop. A new ergonomically friendly design reduces the impact to your hands while an internal ring centers the natural buffalo skin heads for accurate placement.



<b>CONGAS</b>	
<b>PCW110DXPJD580</b>	11" QUINTO
<b>PCW117DXPJD580</b>	11.75" CONGA
<b>PCW125DXPJD580</b>	12.5" TUMBA

<b>BONGOS</b>	
<b>PBW300DXJD580</b>	7" & 8.5"

# CONGAS & BONGOS

Tools of the Trade

## ELITE SERIES



### ELITE WOOD-FIBER CONGAS

**PWFC110DX648** - 11" QUINTO  
**PWFC117DX648** - 11.75" CONGA  
**PWFC125DX648** - 12.5" TUMBA

SHELL	Blended, Thai Oak over Fiberglass
HEADS	Natural Cow Skin
RIMS	Contour Crown
HARDWARE	Brushed Steel
FINISH	#648 Maduro Brown

### ELITE WOOD-FIBER BONGOS

**PWFB100DX648** - 7" & 8.5"



### ELITE OAK CONGAS

**PCW110DX504** - 11" QUINTO  
**PCW117DX504** - 11.75" CONGA  
**PCW125DX504** - 12.5" TUMBA

SHELL	100% Thai Oak
HEADS	Premium Natural Cow Skin
RIMS	Contour Crown
HARDWARE	Chrome
FINISH	#504 Mocha Burst

### ELITE OAK BONGOS

**PBW300DX504** - 7" & 9"



### ELITE OAK CONGAS

**PCW110DX510** - 11" QUINTO  
**PCW117DX510** - 11.75" CONGA  
**PCW125DX510** - 12.5" TUMBA

SHELL	100% Thai Oak
HEADS	Premium Natural Cow Skin
RIMS	Contour Crown
HARDWARE	Brushed Steel
FINISH	#510 Caramel Brown

### ELITE OAK BONGOS

**PBW300DX510** - 7" & 9"



### ELITE OAK CONGAS

**PCW110DX506** - 11" QUINTO  
**PCW117DX506** - 11.75" CONGA  
**PCW125DX506** - 12.5" TUMBA

SHELL	100% Thai Oak
HEADS	Premium Natural Cow Skin
RIMS	Contour Crown
HARDWARE	Chrome
FINISH	#506 Merlot Burst

### ELITE OAK BONGOS

**PBW300DX506** - 7" & 9"



### ELITE FIBERGLASS CONGAS

**PCF110DXA** - 11" QUINTO  
**PCF117DXA** - 11.75" CONGA  
**PCF125DXA** - 12.5" TUMBA

SHELL	Fiberglass
HEADS	Premium Natural Cow Hide
RIMS	Contour Crown
HARDWARE	Brushed Steel
FINISH	#641 Blue Sparkle Burst

### ELITE OAK BONGOS

**PBF300DXA** - 7" & 9"



### ELITE OAK CONGAS

**PCW110DXG** - 11" QUINTO  
**PCW117DXG** - 11.75" CONGA  
**PCW125DXG** - 12.5" TUMBA

SHELL	100% Thai Oak
HEADS	Premium Natural Cow Skin
RIMS	Contour Crown
HARDWARE	Gold
FINISH	#535 Satin Black

### ELITE OAK BONGOS

**PBW300DXG** - 7" & 9"

Also available in #532  
Cherry Eucalyptus

## HAVANA SERIES

### HAVANA CONGAS PCF110HV - 11" QUINTO

### PCF117HV - 11.75" CONGA

### PCF125HV - 12.5" TUMBA

### HAVANA BONGOS PBF300HV - 7" & 8.5"



The wide belly shape of these high end, fiberglass drums produce deeper low tones and greater volume.

SHELL Fiberglass  
HEADS Natural Cow Skin  
RIMS Contour Crown  
HARDWARE Chrome  
FINISH #644 Liquid Gold

SHELL Fiberglass  
HEADS Natural Cow Skin  
RIMS Contour Crown  
HARDWARE Chrome  
FINISH #187 Silver White Swirl

SHELL Fiberglass  
HEADS Natural Cow Skin  
RIMS Contour Crown  
HARDWARE Chrome  
FINISH #651 Red Tiger Stripe

## PRIMERO PRO

### PRIMERO PRO FIBERGLASS

### PRIMERO PRO OAK



11.75" & 12.5" Conga Set #628 Blue Marble  
Shown with matching bongos  
**PFC302DX628**



10" & 11" Conga Set  
#621 Wine Red Marble  
**PFC202DX621**



7" & 8.5" Bongos  
#523 Carbon Vapor  
**PWB100DX523**  
11.75" & 12.5" Congas  
#523 Carbon Vapor  
**PWC302DX523**

PFC302DX626 #626 Gold Marble



Designed with professional features at an affordable price. Our expanded range of sizes offers 10" & 11" and 11.75" & 12.5" sets in both Thai Oak and Fiberglass with matching bongos.

#### PRIMERO PRO FIBERGLASS

**PFC302DX**  
(11.75" & 12.5" Conga Set)  
**PFC202DX**  
(10" & 11" Conga set)

Offer added durability of fiberglass and are louder drums with a crisper sound than wood.

SHELL Fiberglass  
HEADS Buffalo Skin  
RIMS Contour Crown  
HARDWARE Brushed Steel  
FINISH #621 Wine Red Marble  
#626 Gold Marble  
#628 Blue Marble

#### PRIMERO PRO OAK

**PWC302DX**  
(11.75" & 12.5" Conga Set)  
**PWC202DX**  
(10" & 11" Conga set)

Primero Pro wood congas are made with Thai Oak and produce a warm, rich tone.

SHELL Thai Oak  
HEADS Buffalo Skin  
RIMS Contour Crown  
HARDWARE Brushed Steel  
FINISH #511 Natural  
#521 Midnight Fade  
#523 Carbon Vapor

## PRIMERO



10" & 11" Conga Set w/ PC300 Stand  
**PFC203602**

Primero Series congas and bongos are available with fiberglass shells and in packages that include a double stand (PC300W) or without stands.



10" & 11" Conga Set  
**PFC202602**

SHELL Fiberglass  
HEADS Buffalo Skin  
RIMS Contour Crown  
HARDWARE Black Powder Coat  
FINISH #602 Bistre Black

## CONGA RESO-PLATE



Designed for the seated conga player, Pearl's Reso-Plate will give you that hard surface desired for maximum resonance. Configured with a cutout handle, the plates can also easily be placed on top of your drums for extra protection when packed in your conga case.

Conga Reso-Plates  
**PRP140**

# TRAVEL

## Congas, Bongos, & Timbales



Where can you take the Pearl Travel Congas and Bongos? The answer is anywhere you can take traditional drums but without any of the hassle. The Travel Congas feature a 3.5" deep wood shell with stave construction and Remo Symmetry heads. Available in three sizes: 11" x 3.5", 11.75" x 3.5" and 12.5" x 3.5" each with five precision Allen bolts. The 7" and 8.5" Travel Bongos feature 3.5" Thai Oak shells with Remo Fiberskyn heads and three point tuning. The Travel Congas and Bongos include a foam-handle tuning wrench.



### CONGAS



11.75" Travel Conga  
#510 Caramel Brown  
**PTC1175N**

12.5" Travel Conga  
#510 Caramel Brown  
**PTC1250N**

11" Travel Conga  
#510 Caramel Brown  
**PTC1100N**



Travel Conga Bag  
**PSC1175TC**



Travel Bongos Bag  
**PSC785TB**

The optional Travel Conga Stand works with all three size drums and features a tension lever mounting system that locks the drum into place. The wide based, double braced legs provide a solid foundation for your drum and prevents the stand from moving during performance.

# TIMBALES



MARC QUIÑONES  
Doobie Brothers

### MARC QUIÑONES SIGNATURE TIMBALES



Marc Quiñones  
Signature Timbales  
14"x7" / 15"x7" Steel  
w/ PT900 Tilting Stand  
and PBL30 Clave Block  
(Cowbell Not Included)  
**ETE1415MQ**



Primero Timbales  
13"x6.5" / 14"x6.5" Steel  
w/ PT900 Tilting Stand  
(Stands & Cowbell Included)  
**PTS5134**



Primero  
13"x7" Steel Timbale  
w/ PPS36 Mount  
**PTE1336**



Flat Timbale w/ I.S.S.  
13"x3" Steel  
**PTE3131**



Flat Timbale w/ I.S.S.  
13"x3" Brass  
**PTB3131**



## BONGOS



Travel Bongos  
#510 Caramel Brown  
**PTB785**



Travel Conga Stand  
w/ Carrying Bag  
**PC800TC**

Travel Bongos Stand  
**PC800TB**  
**PC800TBS** (Short)



## TIMBALES



Travel Timbales 14" & 15"  
with Stand\*  
**PTTM1415**

\*Bag sold  
separately



The Pearl Travel Timbales feature 14" and 15" steel shells that are professional size in diameter but only 4" deep.



The drums are connected by a hinge that marries them to the Quick Release stand. The custom hinge allows the drums to be folded together into the size of one standard depth timbale for easy storage and transportation.



The Travel Timbales come with and a single braced stand that includes an 11.25" adjustable accessory post with 6 positions that allow cowbells and blocks to be placed the perfect distance from the player.



The steel shells feature a black lacquer finish and USA Remo clear Ambassador heads for a truly professional sounding instrument. A soft carrying case for the stand is also included (sold separately).

## COWBELLS

Pearl and Grammy Award winning artist Horacio Hernández have developed the ultimate family of cowbells. The HH4XH bell features a quick release system that allows the bell to lift easily off of its mount for hand held playing.

**HORACIO HERNÁNDEZ**  
Latin Legend



### HORACIO HERNÁNDEZ SIGNATURE COWBELLS



Marybell  
**HH5**

Hand-Held Campana  
Quick Release  
**HH4XH**

Isabell  
Mambo Bell  
**HH4**

Chabella  
**HH3**

Clabell  
**HH2**

Bella  
**HH1**

### AGOGO & TRIBELLS



Tri-Bells  
**PTB30**

Hand-Held  
Agogo  
**ECB22**

Mounted  
Agogo  
**ECB23**

### NEW YORKER BELLS



Cha-Cha (High)  
**BCM3NY**

Cha-Cha (Low)  
**BCM5NY**

Mambo  
**BCM7NY**

Marc Quiñones  
Sig. Timbale Bell  
**BCM8NYQ**

### BALA BELLS



Mounted  
Campana Bell  
**BCM10**

Hand-Held  
Campana Bell  
**BCH10**

### AGOGO & TRIBELLS



Tri Agogo  
**PTA30**

Pro  
Cowbell Beater  
**PDC60**

Dual  
Cowbell Beater  
**PDC10**

### PRIMERO COWBELLS



10" Bell w/ PPS30  
**PCB1030**

6" Bell  
**PCB6**

4" Bell  
**PCB4**

8" Guiro Cowbell  
**PCB10GR**

10" Millennium Chrome Bell  
**PCB10MCR**

10" Anarchy Bell  
**PCB20**

NOTE: Items pictured are not to scale

# DJEMBES

Ancient Instruments for the Modern Percussionist

**TOP TUNED DJEMBES**

Seamless Synthetic Shell w/ Fiber Style Head

**ROPE TUNED DJEMBES**

#685

ARTISAN STRAIGHT GRAIN LIMBA



12" x 24"  
**PBJV12685**

#686

ARTISAN WEATHERED OAK



12" x 24"  
**PBJV12686**

#684

ARTISAN CYPRESS



12" x 24"  
**PBJVR12684**

#685

ARTISAN STRAIGHT GRAIN LIMBA



12" x 24"  
**PBJVR12685**

14" x 25.75"  
**PBJV14685**

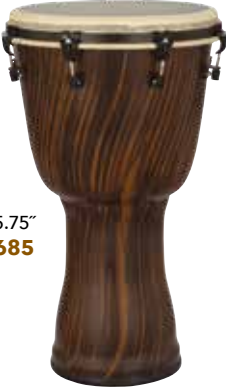

14" x 25.75"  
**PBJV14686**



14" x 25.75"  
**PBJVR14684**



14" x 25.75"  
**PBJVR14685**



**DJEMBES** are a traditional African instrument that offer a wide variety of sounds and are perfect for drum circles.



12" Hand Carved Mahogany Djembe  
#695 Malinke Village  
**PBJWR12695**



Elite Oak Djembe  
12.5"  
#511 Natural  
**PJW340**



Elite Fiberglass Djembe  
#602 Bistre Black  
**PJF350** 14"  
**PJF320** 12.5"



Fiberglass Fun Drum  
**PFD300**



Djembe Stand - Fits 8" to 14" Pearl Rope Tuned and Top Tuned Djembes  
**PBJSTD**



**PBJWR12695**



**DJEM-BASS**



Djem-Bass  
**PJB350**

The **PJB350** Djem-Bass Attachment allows you to convert any Pearl 14" djembe into a sub-sonic bass drum. To reduce the attack and add greater "lows," we have included a cloth cap that stretches around the head. For smoother low-end with a slightly reduced attack, slip the included neoprene disc inside, allowing for two distinct sound options. A pedal (not included) attaches via an I.S.S. clamp to the djembe's stand mounting plate. Includes two legs with mounting hardware, pedal bracket, head cover and neoprene muffler.

# FOLKLORIC

## FOLKLORIC ELITE CONGAS

Pearl's Folkloric line of congas feature a traditional look with modern innovation that only Pearl can deliver. Each 28" tall Oak drum is designed for the "seated" player, but includes stand mounts for players who prefer to stand. Thicker South American-style natural skin heads make the drums warm-sounding, but a fiberglass gel coating on the interior seals the shell and add the projection and volume desired by today's players. Four Polished Steel Reinforcing Bands are inset on the shell for a smooth touch, and the traditional hoops complete these stunning Cuban instruments.



Tumbador 12.5" **PCW125FC** Qunito 11" **PCW110FC** Segundo 11.75" **PCW117FC**  
#526 CRIMSON SUNRISE  
Folkloric Elite Bongos 7" & 8.5" **PBW300FC**



Uno **PSK50FC** Segundo **PSK60FC** Caja **PSK70FC**



Fiberglass Shekere **PSK10**

## BATAS

Bata drums originated in Nigeria over 500 years ago and were primarily used for religious purposes. The drums were introduced into Cuba by slaves in the 1820's. Pearl Batas are modeled after an ancient Cuban design and feature naturally finished 100% Thai Oak shells for outstanding and authentic tone. Polished steel traditional rims offer excellent tuning integrity and ease of tuning. These prized ceremonial drums have an hourglass shape and produce a great, warm tone similar to a bongo-like sound on the high drum and a djembe-like tone on the large drum.



Itotele **PBA60** Oconcolo **PBA50** Iya **PBA70**



Wood Clave **PCL20FCW**



Bamboo Clave **PCL10FCB**



Shekere Holder **PPS45**



Achere **PAC10FC**



Guataca **PGT10FC**



Cata w/ Holder **PCA14FC**

# BRAZILIAN

## BRAZILIAN PERCUSSION

Modern refinements and Pearl quality to the traditional Samba musician.

The Timbao is made from lightweight fiberglass, and is capable of the extremely high tension utilized in tradition Brazilian ensembles. The lightweight wood shell Surdos allow for hours of comfortable play when worn over the shoulder with the provided strap. Available in 18"x22", 20"x18" and 22"x22" sizes (diameter x depth), Pearl's popular Surdos continue to be the industry standard.

Our Repinique features lightweight yet sturdy steel shells with etched heads, shoulder straps and low rims for incredible playing comfort.



Timbao **PBTB140** Tan Tan **PBTA1420** Surdo 20" **PBS2018** Surdo 18" (Shown with optional PBS30BD) **PBS1822** Surdo 22" **PBS2222** Legs & BD Adapter Kit For Surdo **PBS30BD**

Tamborim Stick **PBT70S**



Surdo Mallet **PBSM20**



Caixa 12"x4" **PBCX1204** Caixa 12"x6.5" **PBCX1265**



Cuica **PBC80SS**



Repinique 10" w/ Strap **PBR10S**



Repinique 12" w/ Strap **PBR12S**



Pandeiro 10" (5 Sets Platinellas & Goatkin Head) w/ Bag **PBP510**



Pandeiro 12" (6 Sets Platinellas & Plastic Head) w/ Bag **PBP612**



Pandanza w/ Agogo Bell **PDZ510**



Tamborim w/ Quick Draw Mount **PBT60C**

GET IN THE CAJON ZONE!

**PRIMERO CAJONS**

BODY	Medium-density Fiberboard
SNARES	Fixed, two sets
BASS PORT	Patented, built in, rear facing

The body of these Primero cajons is constructed using MDF, Medium-density Fiberboard which creates a solid and durable sound chamber. Four of these models feature Meranti faceplates. Meranti is a wood known for its relative hardness and straight grain making it ideal for cajons. A built in bass port magnifies the massive low-end tone of the cajon while two sets of fixed snare wires provide a bright, crisp snare response. Each of these Primero cajons feature a look as distinctive as the percussionist who play them.



19.25”T x 11.75”W x 11.75”D

Primero  
Abstract Red Cajon  
**PBC120B**

FACEPLATE	Meranti Replacement Model # FP123B
FINISH	Abstract Red body with black faceplate



Its unique finish is an abstract red print on a cloth sarong that is applied to the body of the cajon and is accentuated by the ebony front.



19.25”T x 11.75”W x 11.75”D

Primero  
Figured Cherry Cajon  
**PBC121B**

FACEPLATE	Figured Cherry Replacement Model # FP123B
FINISH	Natural Figured Cherry with gloss black body

Features a stunning figured Cherry faceplate. Because of its hardness, tonally cherry is a close match to maple and when used on a cajon provides more bottom-end.



19”T x 13”W x 13.25”D

CENTIGRADE CAJON

**PCJ650CG**

This Fiberglass cajon features a front faceplate with 100° of angle for less stress on your lower back. The molded rear bass port projects a full, rich bass tone.

650 Mango  
Cherry Burst



19”T x 12.75”W x 12.5”D

SAMBAJON

**PCJSBJ**

This Fiberglass cajon has two playing surfaces: a traditional hardwood front faceplate and a padded, cloth covered side that produces a Brazilian Surdo / “808 style bass tone. Perfect for use with any cajon pedal.

Black Lacquer Finish



18.75”T x 12.5”W x 14”D

CYCLONE CAJON

**PCJ647CYC**

The Cyclone Cajon is the latest in our diverse offerings of unique Peruvian instruments. Finished in a classy black lacquer and featuring stylish Burnt Orange racing stripes, this curved-back fiberglass cajon is as hip looking as it is sonically powerful.



Two-Face Cajon

**PBC-512TF**

The New 2Face Cajon from Pearl Percussion has two distinct personalities. The professional quality wood construction box drum is ported on the side with two different playing faces on the front and back.

#512 Sheer Black



Cube Cajon

**PCCS-629**

Pearl Percussion is proud to introduce its newest member to its family of cajons, the Cube Cajon! Small in stature, but large in sound.



18.5”T x 14”W x 14”D

VEDGE TRI-SIDE CAJON

**PCJ3000B**

This unique pie slice shape offers a natural seated playing position and 2 striking surfaces. Fiberglass construction with fixed snares and Artisan II finish. Ported in rear.



18.75”T x 12.5”W x 12.75”D

BOOM BOX CAJON

**PCJ633BB**

This Fiberglass cajon with fixed snares features a built in bass port that magnifies subsonic frequencies for great bass projection.

#633 Artisan Red Mahogany



19.75”T x 12.5”W x 12.5”D

PRIMERO BOX CAJON

**PBC507**

Get started with Primero. Constructed from Asiatic Pine with fixed snares, this model has the right pitch and price.

#507 Gypsy



13.75”T x 9.5”W x 10”D

FUN BOX CAJON

**PFB300**

Help your child develop proper playing mechanics while playing this smaller kid-friendly size cajon. Durable Fiberglass construction finished in bright yellow.



18.75”T x 12.5”W x 12.5”D

**Jingle Cajon  
PCJ629616**

FACEPLATE	Asiatic hardwood
BODY	Fiberglass
SNARES	Fixed, three sets
BASS PORT	Rear facing
FINISH	#616 Artisan Wood Grain

Simply twist open the Brazilian Platinella-style jingles and a new world of sonic options open up, as you sound like two percussionists blending simultaneously.



18.75”T x 12.5”W x 12.5”D

**Boom Box Cajon  
PCJ633BB635**

FACEPLATE	Asiatic hardwood
BODY	Fiberglass
SNARES	Fixed, three sets
BASS PORT	Built in, rear facing
FINISH	#635 Artisan Zebra Wood

The Boom Box Cajon creates never-before-heard low-end frequencies from a Fiberglass cajon! Features a fixed snare system and a built-in bass port for subsonic frequencies you have to hear to believe!



18.75”T x 12.5”W x 12.5”D

**BRUSH BEAT CAJON**

**PCJ633BT**

Fiberglass construction enhances the projection of this unique cajon. The black portion features a textured surface that responds well to brushes and other effects. Fixed snares provide a crisp response through the rear facing bass port.



13”T x 14”W x 20”D

**Box Cajon Case  
PSC1213CJ**

Sized to fit most box cajons Pearl's case features heavy-duty nylon construction, plush padded interiors, ergonomic carrying handles, durable double zippers, an external pouch and rubber feet at the ground-resting points.



**CAJH100  
Cajon Holster Nylon w/ Velcro Straps**

**CAJON ACCESSORIES**

Enhance your performance by adding dynamic new sounds. Jingle Cups can be added to the face of any Cajon or even to acoustic guitars and other drums. The Cajon Clave and Wood Blocks attach to your cajon using the provided 3M Dual-Lock Tape or can be played handheld or stand mounted. The Cajon seat cushion



**PSCBC  
at Cushion  
ck Foam. Adds  
for long sessions.**



**PBCW10  
Wood Block w/  
Lock Tape & Mo  
Bracket (PPS37 Not  
Included)**



**PJCP1/6  
Jingle Cup  
Two Pack  
Suction Cups  
Attach to the  
Cajon Face**



**PBCR1000  
3 Way Cajon Riser  
First Lift = 21”, Second Lift = 23”,  
Third Lift = Angled Option**



**PBCC100  
Clave Block w/ Dual-  
Lock Tape & Mounting  
Bracket (PPS37 Not  
Included)**



**PCJ-70  
Cajon Stand**

Fits every cajon model.  
Height Adjustable  
Maximum Stability



**PCC-100  
Cajon Clapper**

The Cajon Clacker is a new Pearl cajon accessory by Bart Fermie, combine “clak” sound with Box Cajon.



**PCCT-100  
Cajon castanet**



**PCAP-100  
Agogo bell**

This easy-to-attach accessory provides a sharp cutting sound to your cajon percussion rig.



**PCAM-100  
Agogo bell**

Easily enlarge your sound Hook-and-loop fastener



**PSC-BC1213  
BASS CASE**

The PSCBC1213 BassCase allows you to transport your prized cajon in protected style and then convert the case into an incredible sounding bass drum. The PSCBC1213 BassCase is constructed from heavy duty black nylon and has a mounted 13” drum head with internal muffling.

# HANDPANS

*A Cosmic Blend of Sound*

## MELODIC HANDPAN



22" Melodic Handpan  
9 Note D Minor - Patina Finish  
**PBHP500**

Handpans are musical instruments that are a subset of the steelpan. The beautiful tonal characteristics will remind you of steel drums, but handpans are only played by hand, with no sticks or mallets, so the sound has reduced attack but is much more mellow.

The shape of Pearl's 22" Awakening Series Melodic and Euphonic handpans feature a center tone field surrounded by eight tone fields. Each tone field has a fundamental note, an octave, and an overtone, so each field has three notes. The hand-crafted steel construction of the instrument is designed so each tone field holds its tuning.

The Melodic handpan features a patina finish and is meticulously tuned to the D Minor scale, and responds to your finger strikes with excellent sonority.

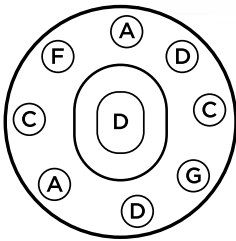

Hand Hammered Tone Field



Rubber Edge Protection



Padded Case Included

## HANDPAN ACCESSORIES

*NOTE: Items pictured are not to scale*



8" x 1.75" Donut  
Foam Wrapped PVC

Handpan Table Top Stand  
**PTTD10**



Adjusts from 36"-40" tall

Handpan Floor Stand  
**PBFS30**



Fits any 20"-22" handpan

Handpan Case  
**PBHPB50**

# TONGUE DRUMS

*Cosmic Blend of Tones*

## AWAKENING SERIES TONGUE DRUMS

Pearl proudly introduces the Awakening Series of 6 Tongue Drums: Three 8 note and three 9 note drums tuned to pentatonic scales.

Tongue drums derive their name from the tongue shaped areas where you strike the drum. The results are a cosmic blend of tones that are as much fun to hear as play.



8 Note G Major #687 Blue Burst  
**PMTD8GMF687**



8 Note A Ake Bono #688 Brown Burst  
**PMTD8AKBF688**



8 Note A Minor #689 Green Burst  
**PMTD8AMF689**



9 Note C Lydian #690 Orange Burst  
**PMTD9LYDF690**



9 Note C Major #691 Crimson Burst  
**PMTD9CPTF691**



9 Note C Ake Bono #692 Purple Burst  
**PMTD9AKBF692**



9 Note C Ake Bono #692 Purple Burst  
**PMTD9AKBF692**



*Rubber mallets included*

Each drum features a 10" hardened steel shell with precise laser cut tongues for accurate and consistent tuning. Pearl Tongue drums can be played with your fingers or with a set of mallets included with each drum.

## TONGUE DRUM BAG



Tongue Drum Bag  
**PTDB10B**

# AWAKENING SERIES

## Rainsticks and Nut Shakers

### RAINSTICKS

#### BAMBOO RAINSTICKS WITH BURNED FINISH #694 RHYTHM WATER

60" Bamboo Rainstick <b>PBR SB60694</b>		Pearl's natural Bamboo Rainsticks are 2.5" in diameter and feature an internal spiral maze of tines that a cascade of lava pebbles flow over to create the soothing sound of falling rain.
48" Bamboo Rainstick <b>PBR SB48694</b>		
40" Bamboo Rainstick <b>PBR SB40694</b>		
32" Bamboo Rainstick <b>PBR SB32694</b>		
24" Bamboo Rainstick <b>PBR SB24694</b>		
16" Bamboo Rainstick <b>PBR SB16694</b>		
Pearl has expanded its line of shakers to include six Bamboo rainsticks ranging in size from 16" to 60" and available in two unique finishes.	     	16" Bamboo Rainstick <b>PBR SP16693</b> 24" Bamboo Rainstick <b>PBR SP24693</b> 32" Bamboo Rainstick <b>PBR SP32693</b> 40" Bamboo Rainstick <b>PBR SP40693</b> 48" Bamboo Rainstick <b>PBR SP48693</b> 60" Bamboo Rainstick <b>PBR SP60693</b>

#### BAMBOO RAINSTICKS WITH PAINTED FINISH #693 HIDDEN SPIRIT

### NUT SHAKERS

The Awakening Series has been expanded to include a series of natural nut shakers that provide earthy tones that complement the series. Kenari, Bendo, and Pangli nuts range in size from small,

medium, and large and each size possesses unique sound properties. From the recording studio to the yoga studio Pearl's Awakening Series has an instrument and sound that will inspire you.



Pangi Nut Shaker w/ Rope Handle  
**PB PGRH14**



20 INDIVIDUALLY STRUNG PANGI NUTS  
Deeper, earthy tone.



Pangi Nut Shaker w/ Bamboo Handle  
**PB PGBH12**

**BAMBOO HANDLE**  
Gives player more control.

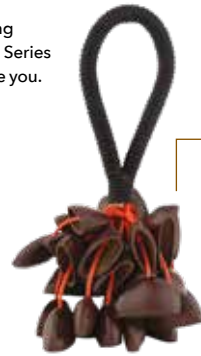

Bendo Nut Shaker w/ Rope Handle  
**PB BDKRH**



16 STRANDS OF BENDO NUTS  
Bright, woody tone.



Kenari Nut Bracelet Shaker  
**PB GLKEN**



14 HAND STRUNG KENARI NUTS  
Worn to layer sounds.



26 Kenari Nut Wind Chime \*Clamp not included  
**PB KENCH01**



**MAHOGANY CROSS BAR**  
Suspended nuts for unique earthy sounds.



Kenari Nut Shaker 7"  
**PB SHKENL**



22 STRANDS OF KENARI NUTS  
Full, robust tone.



# CONCERT PERCUSSION

Engineered for the Professional Percussionist



Pearl is proud to offer Concert Percussion instruments that are attractively priced for school ensembles, yet engineered with the professional percussionist in mind. The symphonic tambourine is a perfect example. Its 17 pairs of specially aged, stamped brass jingles provide a dry, yet bright tone that brings added color to any musical situation. Its 10" headed wood frame allows the player to effortlessly

perform all tambourine techniques, and the tambourine's plush carrying case is included. The rattler is another vital component to any concert percussionists' equipment, and Pearl's is built with an extended handle for a comfortable grip and ease of playing. Holders for the rattler and castanets are also available.



Mix Copper And Brass  
**PETM1018CR**

Mix Copper and Bronze  
**PETM1018CB**

Mix German Silver and Copper  
**PETM1018GC**

Beryllium Copper  
**PETM1018CP**

German Silver  
**PETM1018GS**

## ORCHESTRAL TAMBOURINES

The Pearl Orchestral Series Professional Tambourines provide performers a new voice and sound for any performing situation.

These 5 instruments feature uniquely sourced and hand-hammered jingles combinations of German Silver, Phosphor Bronze, Beryllium Copper, and Yellow Brass that give a full spectrum of color and projection options to players. The 10" shell is a well-

balanced and lightweight 2-ply Mahogany design with contoured hand-hold areas for comfortable performance and warm tone. The natural finish goatskin head provides a full responsive sound and traditional look without sacrificing durability.



16" Ocean Drum  
**PSFM16**



14" Frame Drum  
**PFR14C**



Frame Drums Set of 6 - Sizes: 8", 10", 12", 14", 16", 18"  
**PFR0818C**



Castanets (Long Handle)  
**PCN20**



Castanets  
**PCN20S**



Castanets Holder  
**PCN20H**



Slap Stick  
**PSS100**



Elite Concert Wood Blocks  
(High) (Medium) (Low)  
**PCWB100A PCWB200A PCWB300A**



Mounting Bracket incl.



Stix-Free Triangle Holder w/ 8" Triangle  
**PPS12T**



Triangle  
10" 8" 6"  
**PET100 PET80 PET60**

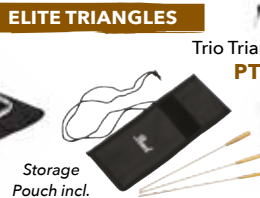

Triangle Beater  
**PETB30**



Trio Triangle Holder  
**PTC300**



Rattler Mounting Clamp  
**PRT10C**



Temple Blocks  
**PCWTB05**



Rattler  
**PRT10**

NOTE: Items pictured are not to scale

# HAND PERCUSSION

A World of Hand Percussion

**BLOCKS, BELLS, SHAKERS** and more. Choose from a complete selection of hand percussion instruments to add color and impact to your music.

## GUIROS



Natural Gourd Guiro  
**PNG20**

Two scraping surfaces: thin grooves on one side for a lighter sound and thicker cut channels on the other side for a beefier sound. The interior is coated with fiberglass gel coat to add projection and volume.



Metal Guiro  
**PMG20**

Perfect for Merengue rhythms, or just a different metallic sound texture, Pearl's Metal Guiro will become an essential ingredient in your "toy" bag. Scraper included.



Fiberglass Guiro  
**PFG20**

Pearl's Fiber Guiro is light-weight and provides optimal projection due to its fiberglass construction. With the included striker and two different playing surfaces you have a world of sonic possibilities in your hand.



Guiro Holder  
**PGH20**

This innovative design will hold virtually any size guiro secure for one handed playing. Easily mountable off the lug of your conga or any 3/8" post, Pearl's Guiro Holder uses a track system to lock the guiro in place. Included is a 3/8" "Z" rod so you can also mount your favorite accessory as well.



Beaded Maracas  
**PFM20**

The Beaded Maracas feature Shekere-style beads which offer an excellent sound with greater control, and foam handles for enhanced comfort.



Maracabasa  
**PFM50**

The Maracabasa is two great instruments in one, combining the functionality of a maraca and a cabasa in one handheld instrument. Featuring a ribbed fiberglass body wrapped in shekere-style beads.



Basket Ganza 9" X 4"  
**PGA20**

The Pearl basket ganza is a 9"x4" woven tube containing wooden sticks instead of conventional shot. The wood sticks produce an airy percussion sound.



Shakelets  
**PWR40**

This innovative percussion item feature exclusive "Ganzinellas", Brazilian-style platinellas combined with ganza shakers that are worn on the wrists to produce a shaker sound when playing.



Spirit Chimes w/  
Holder and Mallet  
**PSC30BR**

Spirit Chimes have many applications in school bands, percussion ensembles and music programs. They are also perfect for meditation and yoga studios.



36 Anodized Aluminum Chimes  
w/ Case, Holder, And Striker  
**PWCH3620A**

- Satin black frame with polished bars
- Self-dampening parallel swinging chimes



32 Bar Aluminum Windchimes  
w/ Case, Holder, and Striker  
**PWCH3220A**

- 32 Anodized Aluminum Chimes
- Self-dampening parallel swinging chimes



Foldable 36 Anodized  
Aluminum Chimes  
**PWCHF3620AF**

- Individually strung, goes from 19.25" to 9.75"
- Self-dampening parallel swinging chimes



Quickmount Tambourine  
w/ Steel Jingles  
**PTM10SHX**

Six double rows of premium steel jingles deliver a bright metallic sound. Features a comfort grip handle that slides into the shock-absorbing Quickmount bracket. Mounts to any 3/8" post.



**QUICKMOUNT BRACKET**  
Hand-held to mounted in seconds.



Ultra Grip Volume Adjustable Tambourine  
**PTM50BHR (Brass)**

The jingle control discs can be moved to the outside to allow the jingles to ring freely. As the jingle control discs are tighten the more restricted the jingle.



Quickmount Tambourine  
w/ Brass Jingles  
**PTM10GHX**

Six double rows of premium brass jingles deliver with bright and a warm metallic sound. Comfort grip handle that slides into the shock-absorbing Quickmount bracket. Mounts to any 3/8" post.



**COMFORT GRIP HANDLE**  
Molded ergonomic shape.



**PTM50SHR (Stainless Steel)**

Brass is an alloy of copper and zinc and the jingles provide a bright mid-range tone. Steel jingles have a higher tone with extra top end and sustain.



9" Primero Rock Tambourine  
w/ Millennium Jingles  
**PTM09BK**

The Primero Rock Tambourine features 6 double sets of Millennium Chrome Jingles in a matte black oval frame.



Headless Wood Tambourines  
**PTH10B (Brass)**  
**PTH10S (Stainless Steel)**

Brass is an alloy of copper and zinc and the jingles provide a bright mid-range tone.



Hi-Hat Jingle Ring  
**PJH10SH**

The Hi-Hat Jingle Ring has 20 sets of Stainless Steel tambourine style jingles that will accentuate your Hi-Hat sound with every opening and closing of your cymbals.



Gatling Cabasa  
**CBS100**

Simply grab the precision handle and fire away to play any pattern you wish, or keep spinning it for an infinite "sizzle" that is not possible with standard Cabasas.

**ASH TONE BLOCKS**



Tang-Tang  
**PTG20**

A high and low pair of unique shakers that incorporate a Caxixi-Style Plate and Wooden "Clacker."



(High) **PAB20** (Medium) **PAB50** (Low) **PAB100**

Pearl's Ash Tone Blocks are constructed using Ashwood because it is extremely hard and durable. The Ash Tone Blocks are pitched in "thirds" and each block includes a mounting bracket that accepts a 3/8" post.

**CLAVE BLOCKS**



(High) **PBL10** (Medium) **PBL20** (Low) **PBL30**

Pearl's clave blocks are injection molded so they're virtually indestructible, and the solid color will never chip, fade, or peel. Our exclusive CDV (Chamber Density Variation) Technology process allows all three clave blocks to be the same dimensions but still differ in pitch.



Anarchy Block  
**PBL100**

Produces a low piercing pitch that will cut through even the heaviest metal rhythm section.



Wood Hex Ganzas  
**PGA30W (Short)** **PGA32W (Long)**

The wood Hex Ganzas are made from Shorea wood and maintain the same strong projection as their aluminum brothers, but deliver a warmer less metallic tone.



Hex Ganzas  
**PGA30 (Short)** **PGA32 (Long)**

The Pearl aluminum Hex Ganzas give more sound control than round shakers and produce a lush shake sound due to their hexagonal shape.



Triple Shaker  
**PGA40**

6" long, rectangular aluminum shaker provides three unique sounds: shake, click, and swish.



Groove Shaker  
**PGA50SF**

Can be played as a traditional shaker or while holding a drumstick.



Egg Carton  
**PEC1**

Three egg shakers in a clear tube that can be played separately or as a complete unit.

# STANDS

Pro Tools for Every Gig

## CONGA STANDS



Quick Release Double Conga Stand w/ Bag  
**PC3000TW**



Quick Release Double Conga Stand  
**PC300W**



Pro Conga Stand  
**PC3000**



All-Fit Conga Stand  
**PC900**

The **PC3000TW** stand holds full size professional congas as securely as most stands double its weight and mass.

The **PC300W** is scaled down to support our lighter Primero Conga lineup. Both stands setup in seconds because there are no wingnuts needed to mount your congas.



Primero Twin Conga Stand  
**PC200**



Ultra Lite Conga Stand  
**PC2500**



Primero Basket Conga Stands  
**PC100P (10") PC110P (11")**

The **PC2500** Ultralite Conga stand, is lightweight yet sturdy and stable. Index markings on all adjustable parts make for consistent lightning fast setups.

## BONGO STANDS



Pro All Fit Bongo Stand with Spring Loaded Strap Hinge  
**PB3000**



Bongo Stand for Seated and Concert Players  
**PB3000S**



All-Fit Tilting Bongo Stand  
**PB900LW**



Lightweight Bongo Stand  
**PB700**



Bongo Attachment for PC200  
**PB700BHS**

## DJEMBE STANDS

PC800S



HEIGHT: 16" to 21"



Pro Djembe Stand  
**PD3000**



All-Fit Djembe Stand  
**PC800S**

## CAJON STANDS



Cajon Stand  
**PCJ70STD**

**TRAP TABLES**

Pearl's wide selection of trap tables and accessories feature sturdy and dependable options for any musical situation. Options include a variety of sizes, construction materials, tables with stands, tray tops and table tops only and single or double braced legs.



Trap Table  
Single Braced (18" x 24")  
**PTT1824**



Trap Table  
Double Braced (18" x 24")  
**PTT1824W**



Aluminum Trap Table (15" x 24") w/o Stand  
**PTT1524MPT**

Aluminum Trap Table (15" x 24") w/ Stand  
**PTT1524MPW**



Tech Tray (8.5" x 11")  
**PTT8511**



Trap Table (12" x 12")  
**PTT1212**

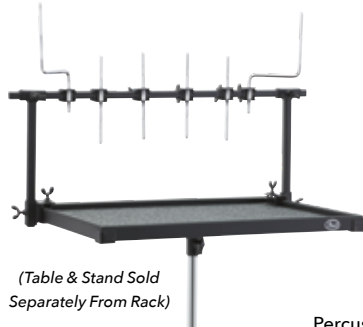

(Table & Stand Sold Separately From Rack)

Universal Trap Table Rack  
**PTRUNV**



Percussion Rack Add On  
**PTR1824**



3/8" Straight Post  
**PTR1824RC1**



3/8" Angled Post  
**PTR1824RC2**



Post Attachment  
**PTR1824RC6**

(FOR PTT1824, PTT1212)



Trap Table Single Post Adapter  
**PTR1824RC3**

**PERCUSSION CASES**

Features include: ergonomic carrying straps, rubber protective bottoms, top-mounted carrying handles, tuning wrench pouches, & heavy duty double zippers.



Box Cajon Case  
13" x 14" x 20"  
**PSC1213CJ**



Travel Conga Case  
**PSC1175TC**

Fits Havana Series



11" & 11.75" Conga Bag  
**PSC117CGW**



12.5" Conga Bag  
**PSC125CGW**



12" Djembe Bag  
**PBJCXL**



14" Djembe Bag  
**PBJCXXL**



Bongo Bag  
**PSCBB**



12.5" Conga Bag  
**PSC125CG**



11" Conga Bag  
**PSC110CG**



14" Djembe Bag  
**PSC140DJ**

**HOLDER & ACCESSORIES**



Angled Post Adapter  
**PPS37**



Lug Mount Accessory Holder  
**PPS40**



Universal Guiro Holder  
**PGH20**



Foot Pedal Bracket  
**PPS20**



Cowbell Stacker  
**PCS10**



Stix-Free  
**PPS10 & PPS11**



Percussion Toy Box (Accessories Not Included)  
**PTYB1212**

**COWBELL HOLDERS**



**CA130**



**75H**



**75X**



**PPS81**



**PPS82**

# REPLACEMENT PARTS

## MASKING COVERS & MOUNTING BRACKET

The GK90 and BBC1 cover the holes of BT3 and BB3 brackets that have been removed.

GK90



BT3

- BBC1** For BB3, w/Gasket, Screws and Nuts
- GK90** For BT3, inside/outside plates w/ Bolts
- BT3** Tom Tom Bracket

## BASS DRUM HOOP PROTECTORS



HPP2

NP347/2

- HPP2** Metal Hoop Protector for Wood BD Hoops
- NP01** Hoop Protector for Metal BD Hoops
- NP347/2** Non-Slip Hoop Protector for Wood BD Hoops (pair)

## P2050 SERIES CAMS

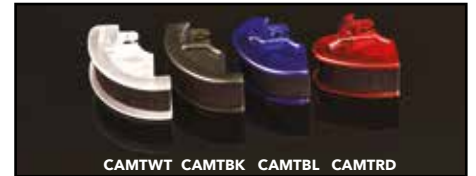

CAMTWT CAMTBK CAMTBL CAMTRD

### ELIMINATOR OPTION CAM

- CAMPL** Purple Cam, Aggressive Action
- CAMYL** Yellow Cam, Inverse Action
- CAMTBK** Translucent Black Cam, Linear Action
- CAMTWT** Translucent White Cam, Oversized Linear Action
- CAMTBL** Translucent Blue Cam, Progressive Action
- CAMTRD** Translucent Red Cam, Radical Action

## CHAINS & BELTS



CCA5

BCA250

- CCA5** Chain Assy Complete for Eliminator Pedals
- BCA250** Belt Assy Complete for P2050 Eliminator Pedals

## SPRING

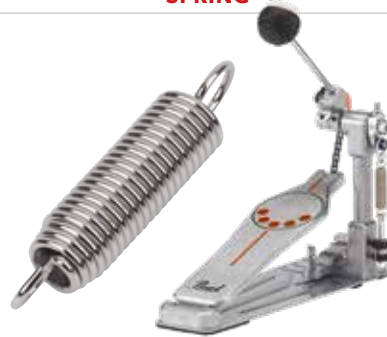

SP64F Spring for P930/P932

## BEATERS & BEATER WEIGHTS



DB100

B250QB

- DB100** Duo-Beater Felt/Plastic
- B250QB** Control Core Quad Beater

### BEATER WEIGHTS

- BW100** Beater Weight, 3 Weights in One (U.S. Patent #7122730)

## BASS DRUM PEDAL TRAINING PAD

**BD10**  
The BD10 bass pad is perfect for practicing at home or on the road. The wide pad accommodates double pedals and is specially formulated for extremely low noise and a realistic feel. The universal-fit "hoop" accepts all brands of pedals and adjusts to compensate for different floor surfaces. The BD10 folds for compact transport.



## QUICK RELEASE WINGLOC



WL230

WL230A

- WL230** Quick Release WingLoc
- WL230A** Quick Release WingLoc Complete

## SEAT CUPS AND FELTS



RC20

PL11

FLW003

- RC20** Reversible Seat Cup, w/ O-Ring
- PL11** Cymbal Seat Cup
- FLW001/2** Cymbal Felt Washer (2 Pieces)
- FLW003** Hi-Hat Cup Felt Washer

## STOP LOCK



ZD081A

- ZD081A** Stop Lock Complete

## DRUM KEYS



PFMDK080

K030

KGT100H

K080

K180

- KGT100H** Gyro Tune Key w/ Quick Release
- K030** Hi-Tension Tuning Key
- K080** Tuning Key
- K180** Spin-Tight Key
- PFMDK080** Flip-Mute-Key

## AIR SUSPENSION FEET



R40/3

- R40/3** Air Suspension Rubber Feet (3 Each)
- R5/3** Rubber Tip

Pearl offers a tremendous number of parts for our drums and hardware. The parts represented on these pages are some of the most commonly requested items.

### FLOOR TOM LEGS & BRACKETS

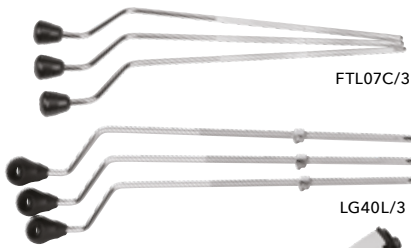

FTL07C/3

LG40L/3

- FTL07C/3** Floor Tom Legs (3 Legs)
- LG40L/3** Long Floor Tom Legs (3 Legs)
- LB40** Leg Bracket for Masters Series

LB40

### HI-HAT CLUTCHES & PARTS

#### RAPID LOCK HI-HAT CLUTCHES

Hi-Hat set-up and tear-down is a breeze with Rapid-Lock's Patented\* two-point quick release locking system. \*U.S. Patent #9355625

- HCL205DQR** Rapid Lock Quick Release Hi-Hat Drop Clutch w/ Locking Nut
- HCL205QR** Rapid Lock Quick Release Super Grip Hi-Hat Clutch w/ Locking Nut
- HCL105QR** Rapid Lock Quick Release Hi-Hat Clutch w/ Locking Nut
- HCL79** Hi-Hat Clutch Complete
- HHC90** Plastic Cup w/ Tilter



HCL205DQR

HCL205QR

HCL105QR

HCL79

HHC90

### MASTERCAST HOOPS

MasterCast are the finest die cast hoops available and feature the perfect blend of thickness and mass to improve the depth, clarity, and focus of toms and snare drums.



Model #	Diameter	# of Tension
<b>DC0805</b>	8"	5
<b>DC1006</b>	10"	6
<b>DC1206</b>	12"	6
<b>DC1306</b>	13"	6
<b>DC1408</b>	14"	8
<b>DC1408S</b>	14"	8 Snare Side
<b>DC1410</b>	14"	10
<b>DC1410S</b>	14"	10 Snare Side
<b>DC1410SG</b>	14"	10 Snare Side w/ Guard
<b>DC1508</b>	15"	8
<b>DC1608</b>	16"	8
<b>DC1808</b>	18"	8

### SUPERHOOP II & FATTONE HOOPS

SuperHoop II hoops are precision formed from heavy-duty 2.3mm steel, triple-flanged and engraved with the SuperHoop II logo. FatTone hoops are low mass 1.6mm hoops with hemmed and welded edges for strength and rigidity.



FatTone Hoops

Super Hoop Model #	FatTone Hoop Model #	Diameter	# of Tension
<b>SH0604</b>	<b>NA</b>	6"	4
<b>SH0805</b>	<b>FH0805</b>	8"	5
<b>SH1006</b>	<b>FH1006</b>	10"	6
<b>SH1006S</b>	<b>NA</b>	10"	6 Snare Side
<b>SH1206</b>	<b>FH1206</b>	12"	6
<b>SH1208</b>	<b>NA</b>	12"	8
<b>SH1208S</b>	<b>NA</b>	12"	8 Snare Side
<b>SH1306</b>	<b>FH1306</b>	13"	6
<b>SH1308</b>	<b>FH1308</b>	13"	8
<b>SH1308S</b>	<b>FH1308S</b>	13"	8 Snare Side
<b>SH1408</b>	<b>FH1408</b>	14"	8
<b>SH1408S</b>	<b>NA</b>	14"	8 Snare Side
<b>SH1410B</b>	<b>FH1410</b>	14"	10
<b>SH1410S</b>	<b>FH1410S</b>	14"	10 Snare Side
<b>SH1410SG</b>	<b>NA</b>	14"	10 Snare Side w/ Guard
<b>SH1508</b>	<b>FH1508</b>	15"	8
<b>SH1510S</b>	<b>NA</b>	15"	10 Snare Side
<b>SH1510B</b>	<b>NA</b>	15"	10
<b>SH1608</b>	<b>FH1608</b>	16"	8
<b>SH1808</b>	<b>FH1808</b>	18"	8



MASTERS MAPLE GUM SHOWN WITH MASTERCAST HOOPS



MASTERS MAPLE COMPLETE SHOWING WITH SUPERHOOP II HOOPS

### STEEL HOOPS

Steel Hoop Model #	Diameter	# of Tension
<b>RH0804</b>	8"	4
<b>RH1006</b>	10"	6
<b>RH1206</b>	12"	6
<b>RH1306</b>	13"	6
<b>RH1408</b>	14"	8
<b>RH1408S</b>	14"	8 Snare side
<b>RH1608</b>	16"	8
<b>RH1808</b>	18"	8



### LUGS

- CL05** Lug for 3" Piccolo Snare
- CL50** Lug for 5" Deep Snare
- CL55** Lug for 5.5" Deep Snare
- CL65** Lug for 6.5" Deep Snare
- CL100** Lug for 7" Deep Snare



CL05

CL50

CL55

CL65

CL100

# REPLACEMENT PARTS

## OPTI-LOC



OPL1016/C

Opti-Loc suspension tom holders provide exceptional stability while greatly improving resonance and sustain. (For EXX / EXL Export / DMP)

- OPL0608/C** Opti-Loc for EXX and DMP 6"-8" Diameter
- OPL1016/C** Opti-Loc for EXX and DMP 10"-16" Diameter

## JUNGLE GIG



**JG16** • Pearl's Jungle Gig allows the conversion of a 16" Floor Tom to a Bass drum.

## OPTIMOUNT

Our OptiMount Suspension System attaches to the tom's tension rods and floats on rubber cushions, providing the ultimate in stability while allowing the drum to resonate fully without restriction. With OptiMount, the mounting hardware is completely removed from the drum shell, providing a drastic improvement in resonance and sustain.



OPTA0708 OPTA0910 OPTA1112



OPT0708 OPT0910 OPT1112



OPT1314 OPT1516

- OPTA0708/C** for drums 7"-8" deep, 6"-16" diameter, Lightweight Aluminum
- OPTA0910/C** for drums 9"-10" deep, 6"-16" diameter, Lightweight Aluminum
- OPTA1112/C** for drums 11"-12" deep, 6"-16" diameter, Lightweight Aluminum
- OPTA1314/C** for drums 13"-14" deep, 6"-16" diameter, Lightweight Aluminum
- OPTA1516/C** for drums 15"-16" deep, 6"-16" diameter, Lightweight Aluminum

- OPT0708** for drums 7"-8" deep, 8"-16" diameter, UltraGrip Wingnut
- OPT0910** for drums 9"-10" deep, 8"-16" diameter, UltraGrip Wingnut
- OPT1112** for drums 11"-12" deep, 8"-16" diameter, UltraGrip Wingnut
- OPT1314** for drums 13"-14" deep, 8"-16" diameter, UltraGrip Wingnut
- OPT1516** for drums 15"-16" deep, 8"-16" diameter, UltraGrip Wingnut

## MUFFLERS

External clamp-on muffler for snare drums and toms. By adjusting the pressure and position of the felt pad, excessive overtones can be precisely controlled or eliminated.



OM1

- OM1** Clamp-on Muffler, Snare Drum & Toms

## MUFFLE HEADS

Model #	Size	Model #	Size
<b>MFH08</b>	8"	<b>MFH14</b>	14"
<b>MFH10</b>	10"	<b>MFH16</b>	16"
<b>MFH12</b>	12"	<b>MFH20B</b>	20"
<b>MFH13</b>	13"	<b>MFH22B</b>	22"

## BASS DRUM MUFFLER



BDMF



BDMM

- BDMF** Bass Drum Muffler (Full Size)
- BDMM** Bass Drum Muffler (Mini Size)

## TENSION ROD LOCKNUTS



TNK10N/10

TL20/10

- TNK10N/10** Tension Keeper (10/pkg)
- TL20/10** Tension Rod Lock Nuts (10/pkg)

## TENSION ROD WASHERS



NLW12B/12

MTW12/12

- NLW12B/12** Nylon Washers (12) Black
- MTW12/12** Metal Washers (12)



Pearl offers a tremendous number of parts for our drums and hardware. The parts represented on these pages are some of the most commonly requested items.

## STRAINERS



SR017

- SR014N** Standard Snare Strainer
- SR017** Snare Strainer Complete
- SR018** Snare Strainer Complete



**THE SR017 STRAINER** Simple and effective, the SR017 is a Pearl standard for effortless snare switching and sensitivity control. Its smooth lever action and fine-tuning knob let you dial in the right amount of snare wire saturation to suit your personal sound.

## ULTRA-SOUND SNARES

Pearl's Ultra-Sound snares feature patented Graduated Tension wires for extended dynamic range from ultra soft to ultra loud. Ultra-thin, low mass end plates assure ultra quick response. The end plates feature three mounting options: tunnels or holes for cord mounting and slots for straps.  
U.S. Patent #7202405



- SN1320C** 20 strands for 13", C-type, w/ straps & cords
- SN1320D** 20 strands for 13", D-type, w/ straps & cords
- SN1320I** 20 strands for 13", I-type, w/ straps & cords
- SN1420C** 20 strands for 14", C-type, w/ straps & cords
- SN1420D** 20 strands for 14", D-type, w/ straps & cords
- SN1420I** 20 strands for 14", I-type, w/ straps & cords



- SN1442C** 42 strands for 14", C-type, w/ straps & cords
- SN1442D** 42 strands for 14", D-type, w/ straps & cords
- SN1442I** 42 strands for 14", I-type, w/ straps & cords

## REPLACEMENT SNARES



- S022N** 20 Strand for 14" w/ Cords
- S022NU** 20 Strand for 14" w/ Cords, Uncoated
- S022** 20 Strand for 14" w/ Straps
- S025** 20 Strand for 14" long, w/ Straps
- S029N** 20 Strand for 13" w/ Cords
- S030N** 24 Strand for 14" w/ Cords
- S031N** 20 Strand for 12" w/ Cords
- S032N** 16 Strand for 10" w/ Cords
- S033N** 16 Strand for 12" w/ Cords
- S040** 15 Strand for 14" w/ Cords, Steel Cable, Thinner Gauge
- S041** 15 Strand for 14" w/ Cords, Bronze Cable, Thicker Gauge
- SPS18/6** Plastic Strap (6/pkg)
- SNC500R/4** Snare Cord (4/pkg)

## SPIN-TIGHT™ TENSION RODS

Specially-designed stainless steel tension rods that lock to maintain tension settings. Starter pack includes 4 Spin-Tight Tension rods with K180 Drum Key.



- SPT5047** W7/32 x 47mm (1)
- SPT45PK** W7/32 x 47mm (4) w/ K180 Drum Key
- SPT6PK** W7/32 x 47mm (6)

## STAINLESS STEEL TENSION RODS

Pearl's Stainless Steel Tension Rods are machined, not forged, from a single piece of stainless steel to the most exacting tolerances in the industry. They feature super-smooth, precise tensioning, with absolutely no play. Each non-plated stainless steel tension rod is matched with a precision-machined brass swivel nut for ultra-precise performance.



- SST5028/6** W7/32 x 28mm (6)
- SST5035/6** W7/32 x 35mm (6)
- SST5038/6** W7/32 x 38mm (6)
- SST5042/6** W7/32 x 42mm (6)
- SST5047/6** W7/32 x 47mm (6)
- SST5052/6** W7/32 x 52mm (6)

## TENSION RODS

- T055/6** W7/32 x 28mm (6) for 3" Deep Snare
- T060/6** W7/32 x 35mm (6) for Free Floaters before 2002
- T061/6** W7/32 x 42mm (6)
- T061L/6** W7/32 x 47mm (6) for 6.5" Deep Snare
- T062/6** W7/32 x 52mm (6) for 5.5" Deep Snare
- T065** M6 x 90mm (Bass Drum)
- T066** M6 x 115mm (Bass Drum)
- TR5052** W7/32 x 52mm (DMP, EXL, EXX, MDT Snare)
- TR5047** W7/32 x 47mm (DMP, EXL, EXX, MDT Toms)
- TR5100** W7/32 x 100mm (Bass Drum)



# PEARL ARTISTS



**AARON SMITH**  
Independent



**ADAM TUMINARO**  
OrlandoDrummer



**ADRIAN BENT**  
Drake/Daniel Caesar



**AREJAY HALE**  
Halestorm



**ALVIN FORD**  
Trombone Shorty



**AUSTIN BURCHAM**  
ABBDRUMS



**BAARD KOLSTAD**  
Leprous



**BARRY KERCH**  
Shinedown



**BEN GORDON**  
Parkway Drive

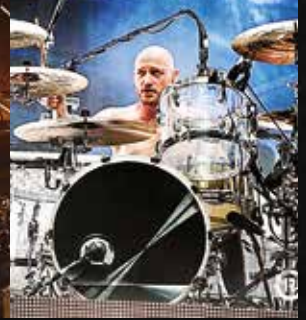

**BEN JOHNSTON**  
Biffy Clyro



**BILLY HART**  
Jazz Legend



**BRANDON PERTZBORN**  
Suicidal Tendencies



**BRANDON COMBS**  
Leon Bridges



**BRIAN FRASIER-MOORE**  
Justin Timberlake / Pink



**BRUNO ESRUBILSKY**  
Mitski



**BRUNO VALVERDE**  
Angra



**CALVIN RODGERS**  
Independent



**CASEY COOPER**  
@COOP3RDRUMM3R



**CHAD SEXTON**  
311



**CHARLIE ENGEN**  
Five Finger Death Punch



**DAN PRESLAND**  
Black Lava/Vipassi/AMDBL



**DANIEL ERLANDSSON**  
Arch Enemy



**DARION JA'VON**  
Doja Cat



**DENNIS CHAMBERS**  
Drumming Legend



**DESMOND DAVIS**  
Mickey Guyton



**EDDIE BAYERS**  
Nashville Legend



**ELISE TROUW**  
Independent



**ERIC SINGER**  
KISS



**FLO MOUNIER**  
Cryptopsy



**FREDO ORTIZ**  
Los Lobos



**GARY HUSBAND**  
Independent



**GENE HOGLAN**  
Dethklok/Dark Angel



**GABE HELGUERA**  
I Prevail



**GEORGE KOLLIAS**  
Nile

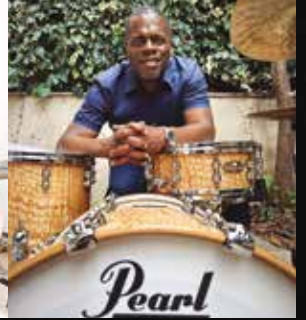

**GREG HUTCHINSON**  
Independent



**GREYSON NEKRUTMAN**  
Independent



**HARRY MIREE**  
Hardy



**HORACIO HERNÁNDEZ**  
Latin Legend



**IAN PAICE**  
Deep Purple



**INFERNO**  
Behemoth



**ISAC JAMBA**  
Independent



**JASON BITTNER**  
Overkill / Shadows Fall



**JASON BOWLD**  
Bullet For My Valentine



**JASON HARTLESS**  
Ted Nugent / Studio

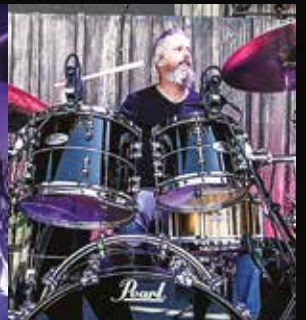

**JEFF MARINO**  
Darius Rucker



**JEN LEDGER**  
Skillet / Ledger



**JERROD SULLIVAN**  
The 4 Korners



**JESSIE CARABALLO**  
Marc Anthony



**JOCKE WALLGREN**  
Amon Amarth

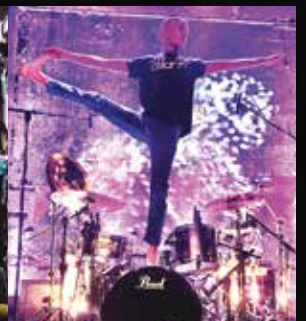

**JOE TOMINO**  
Matisyahu / Dub Trio

# PEARL ARTISTS



**JOE JORDISON**  
In Memoriam



**JOE KRAMER**  
Aerosmith



**JOHN LONGSTRETH**  
Origin



**JON LARSEN**  
Volbeat



**JONATHAN MOVER**  
Independent



**JUAN "CARLITO" MENDOZA**  
Independent



**KAI HAHTO**  
Nightwish



**KEIO STROUD**  
Independent



**KENT SLUCHER**  
Luke Bryan



**KENWOOD DENNARD**  
Independent



**KIKO FREITAS**  
Independent



**KRIS BOWERING**  
Orville Peck



**KRIS MYERS**  
Umphrey's McGee



**LENNY "THE OX" REECE**  
The Lesson GK



**LESTER ESTELLE**  
Kelly Clarkson/Sessions



**LOUIE PALMER**  
Independent



**MARCUS FINNIE**  
Independent



**MARVIN "SMITTY" SMITH**  
Independent



**MATT ABTS**  
Gov't Mule



**MATT HALPERN**  
Periphery



**MATT MCGUIRE**  
The Chainsmokers



**MICHEL'LE BAPTISTE**  
Lizzo

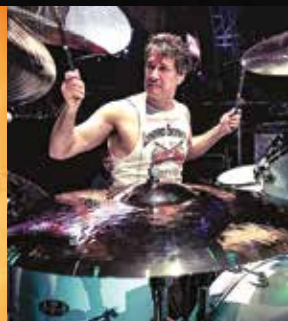

**MICHAEL CARTELLONE**  
Lynyrd Skynyrd



**MIGUEL LAMAS**  
Independent



**MIKE MANGINI**  
Dream Theater



**MIKE MILEY**  
Rival Sons



**MIKE WENGTEN**  
Disturbed



**MORGAN ROSE**  
Sevendust



**NATE MORTON**  
The Voice



**OMAR HAKIM**  
Independent



**PETAR JANJIC**  
Cory Wong



**PETE WEBBER**  
Havok



**QUINTON "Q" ROBINSON**  
Independent



**RAY LUZIER**  
Korn / KXM



**RICKY LEWIS**  
The Weeknd



**ROBBY AMEEN**  
Independent



**SAM LOEFFLER**  
Chevelle



**SERGIO MELO**  
The Voice Brazil



**SHANE GAALAAS**  
Cosmosquad



**SHANNON FORREST**  
Sessions



**TARON LOCKETT**  
Cory Henry And The Funk Apostles



**TAVARIUS JOHNSON**  
Jon McReynolds / Lalah Hathaway



**TERENCE HIGGINS**  
Tab Benoit / Ani DiFranco



**TODD SUCHERMAN**  
Styx



**TONY PALERMO**  
Papa Roach



**TRACY BROUSSARD**  
Blake Shelton



**TROY WRIGHT**  
Independent



**TRAVIS ORBIN**  
Darkest Hour



**WILL HUNT**  
Evanescence



**WILL KENNEDY**  
Yellowjackets / Jazz Legend

# COLOR & CONFIGURATION CHART

PAGES 24 - 25

## MASTERS MAPLE COMPLETE

AN ALL MAPLE DRUM SHELL FIT FOR THE MASTERS LEGACY.

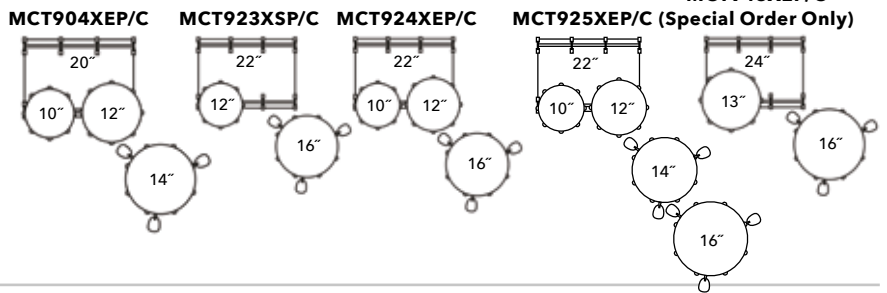

PAGES 26 - 27

## SESSION STUDIO SELECT

A COMPLETELY NEW TAKE ON THE FULL SPECTRUM SOUND.

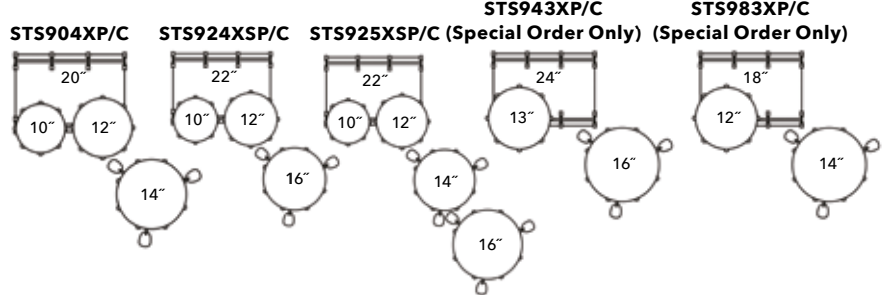

PAGES 28 - 29

## PRESIDENT SERIES DELUXE

A MODERN REVIVAL OF THE DARKLY UNIQUE LAUAN SOUND.

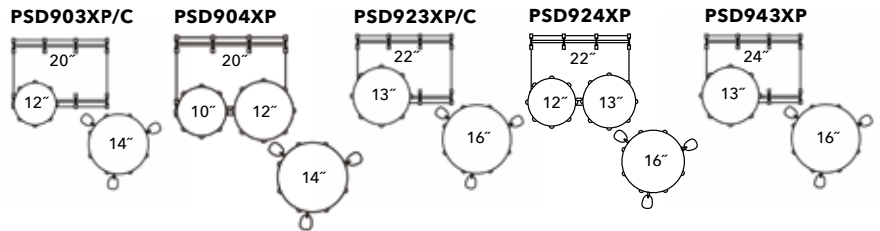

PAGES 30 - 31

## CRYSTAL BEAT

THE ORIGINAL SEAMLESS ACRYLIC DRUM SHELL.

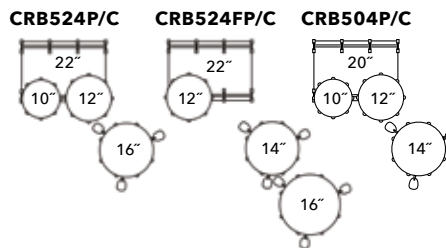

Individual components also available.  
For sizes, visit [www.pearldrums.com](http://www.pearldrums.com)

PAGES 32 - 33

## DECADE MAPLE

A DRUM KIT 10 YEARS IN THE MAKING.

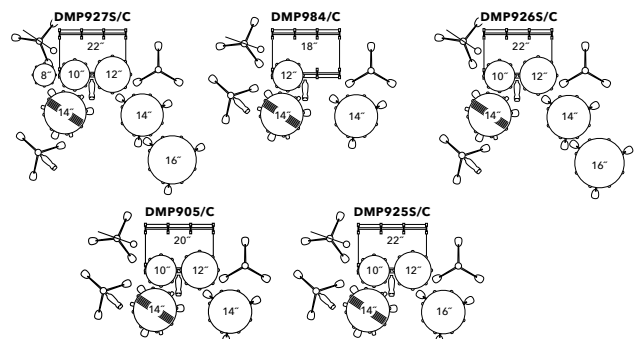

# COLOR & CONFIGURATION CHART

## EXPORT LACQUER THE LEGENDS OF TOMORROW, PLAY EXPORT TODAY.

PAGES 34 - 35



#211 Azure Daybreak #217 Raspberry Sunset



#218 Ember Dawn #219 Indigo Night

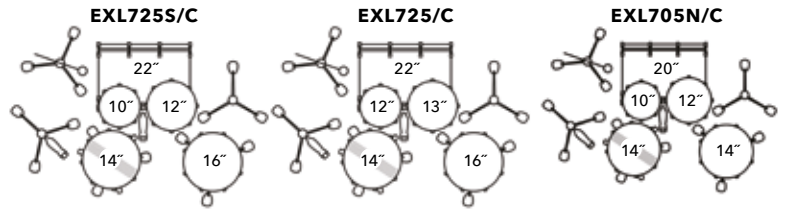

INCLUDES HWP830 HARDWARE PACK

## EXPORT THE BEST SELLING DRUM SET OF ALL TIME.

PAGES 34 - 35



#21 Smokey Chrome #31 Jet Black #735 Satin White



#704 Black Cherry Glitter #717 High Voltage Blue

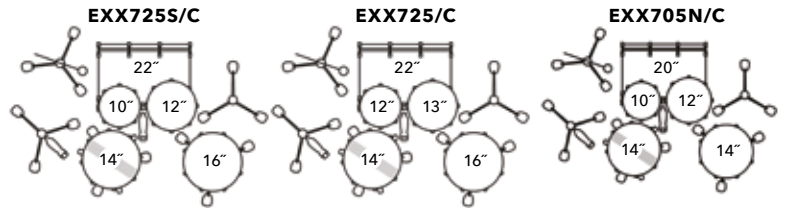

INCLUDES HWP830 HARDWARE PACK

## MIDTOWN BIG GIG, SMALL RIG, HUGE SOUND.

PAGE 36



#49 Mirror Chrome #701 Black Gold Sparkle #704 Black Cherry Glitter

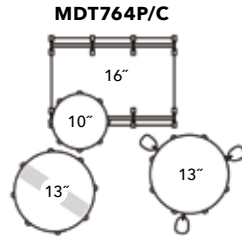

## ROADSHOW JR.

PAGE 37

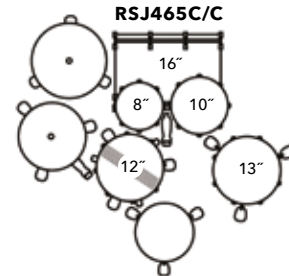

Complete with Hardware, Cymbals, and Throne for Drummers under 8.

## ROADSHOW IT'S YOUR TIME TO PLAY, START THE RIGHT WAY.

PAGE 37



#31 Jet Black #91 Red Wine



#707 Bronze Metallic #743 Royal Blue Metallic

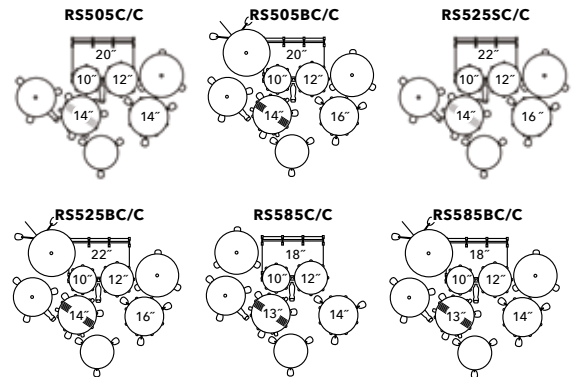

INCLUDES CH50/H50/S50\*/P50/D50/16\"/>

PAGES 10 - 13

## REFERENCE SONICALLY SELECT DRUM PERFORMANCE.



#103 Piano Black

#393 Purple Craze II

#736 Turquoise Pearl

## REFERENCE PURE UNRESTRICTED TONAL RESPONSE.



#124 Matte Black

#843 Osiria Rose Stripe

#844 Satin Rose Gold

RF904XEP/C  
RFP904XEP/C

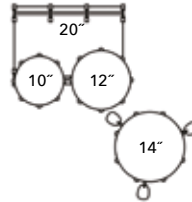

RF924XEP/C  
RFP924XEP/C

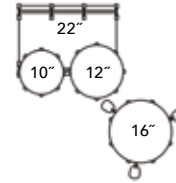

RF943XEP/C  
RFP943XEP/C  
(Special Order Only)

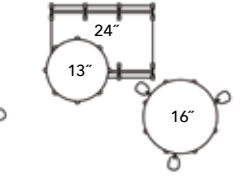

PAGES 20 - 21

## MASTERS MAPLE RESERVE A CLASSIC FORMULA FOR SONIC GREATNESS.



#415 Bronze Oyster

#824 Satin Charred Oak



#850 Aqua Turquoise Stripe

#839 Red Burst Triband

MRV904XEP/

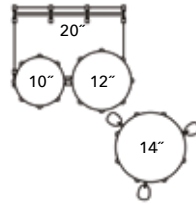

MRV924XEP/

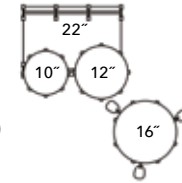

MRV923XSP/

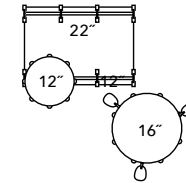

MRV943XEP/  
(Special Order Only)

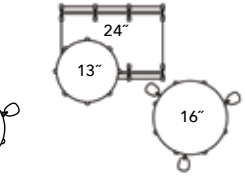

PAGES 22 - 23

## MASTERS MAPLE/GUM THE EVOLUTION OF PREMIUM STUDIO TONE.



#186 Hand Rubbed Natural Maple

#418 Blue Abalone

#453 Platinum Gold Oyster

MMG904XP/C

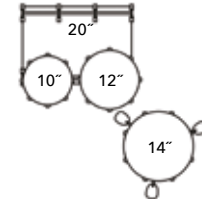

MMG923XSP/C

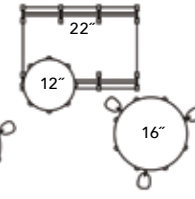

MMG924XSP/C

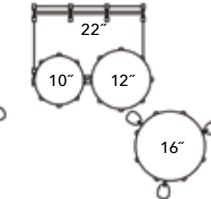

MMG983XP/C  
(Special Order Only)

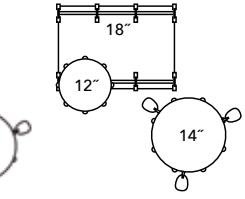



# SPECIAL ORDER LACQUER FINISHES

**SPECIAL ORDER** AVAILABLE IN REFERENCE, REFERENCE PURE, MASTERS MAPLE RESERVE, AND MASTERS MAPLE/GUM SERIES



#100 Wine Red



#103 Piano Black



#111 Matte  
Natural(Maple)



#124 Matte  
Black Mist



#160 Silver  
Sparkle



#165 Diamond  
Burst



#195 Crystal Rain



#201 Matte  
Walnut (Maple)



#310 Brooklyn  
Burst



#347 Bombay  
Gold Sparkle



#353 Matte White



#359 Twilight  
Burst



#376 Ultra  
Blue Fade



#393 Purple  
Craze II



#400 White  
Marine Pearl



#414 Ice Blue  
Oyster



#415 Bronze  
Oyster



#418 Blue Abalone



#422 Matt White  
Marine Pearl



#736 Turquoise  
Pearl



#766 Black Mirror  
Chrome



#824 Satin  
Charred Oak



#839 Red Burst  
Triband



#844 Satin  
Rose Gold



#850 Aqua  
Turquoise Stripe