

1946

**75** *Pearl*<sup>®</sup>  
CELEBRATING  
SEVENTY-FIVE  
YEARS

2021



2021 GENERAL CATALOG



**PRESIDENT SERIES PHENOLIC**

A Diamond Jubilee Edition reissue of one of Pearl's most iconic and celebrated drum sets.

**SHELL RECIPE:** Hermetically Pressurized 4/4.5mm Phenolic.  
**SOUND:** Loud, distinctive resonance with tonally articulate decay.  
p. 4 - 5



**PRESIDENT SERIES DELUXE**

The original "MIJ" sound returns for a darkly traditional, controlled playing experience.

**SHELL RECIPE:** 6-ply, 7.5mm Lauan.  
**SOUND:** Subdued and centered with singular low-range overtone.

p. 6 - 7



**MASTERWORKS**

A custom tailored heirloom instrument for the drummer who wants ultimate control.

**SHELL RECIPE:** Choice/Combination of Birch, Maple, Gum, and/or Mahogany.  
**SOUND:** Any desired sound is possible; you decide!  
p. 8 - 13



**CRYSTAL BEAT**

The original seamless Acrylic drum shell creates a striking visual and sonic showcase.

**SHELL RECIPE:** 7mm Seamless Molded Acrylic.  
**SOUND:** Loud and immediate, delivers pummeling straight tone and yielding feel.

p. 26 - 27



**DECADE MAPLE**

Premium gear for the evolving drummer, featuring lacquered, all Maple shells and pro level elements.

**SHELL RECIPE:** EvenPly-Six, 5.4mm Maple.  
**SOUND:** Full Maple tone with lively midrange and smooth sustain.

p. 28 - 29



**REFERENCE**

Individually engineered with premium Masterworks materials for articulate power and projection.

**SHELL RECIPE:** Reference Recipe Birch, Maple, and Mahogany hybrid.  
**SOUND:** Enhanced output, cutting highs, powerful lows.  
p. 14 - 15



**REFERENCE PURE**

Reference Recipe shell engineering in a lighter format for increased body and sustain.

**SHELL RECIPE:** EvenPly Birch, Maple, and Mahogany hybrid.  
**SOUND:** Expressive, open tonality with responsive bottom-end boost.  
p. 16 - 17



**MASTERS MAPLE RESERVE**

The vintage flair of the original Masters sound for a refined playing experience.

**SHELL RECIPE:** 4-ply Maple w/ 4-ply Reinforcement Rings.  
**SOUND:** Balance of powerful midrange and smooth resonant attack.  
p. 18 - 19



**EXPORT / EXPORT LACQUER**

The Best Selling Drum Set of All Time gives the student drummer a strong beginning.

**SHELL RECIPE:** 6-Ply 7.5mm Poplar/Asian Mahogany Blend  
**SOUND:** Crisp attack with dark, formidable bottom-end vibrance.  
p. 30 - 31



**MIDTOWN**

An ultra portable shell pack for full sized play and powerful grooves in a small footprint.

**SHELL RECIPE:** 6-ply 7.5mm Poplar.  
**SOUND:** Tight, responsive tonal bite with enough bottom to fill the pocket.

p. 32



**MASTERS MAPLE GUM**

Vital, recording optimized tone derived from the Masterworks: Studio shell recipe.

**SHELL RECIPE:** EvenPly-Six Maple (4-ply outer) and Gum (2-ply inner).  
**SOUND:** Explosive midrange, full low-end, precise decay.  
p. 20 - 21



**MASTERS MAPLE COMPLETE**

A road ready sonic powerhouse with inspired custom appointments.

**SHELL RECIPE:** EvenPly-Six, 5.4mm North American Maple.  
**SOUND:** Booming projection with equalized Low/Mid/High frequency mix.  
p. 22 - 23



**SESSION STUDIO SELECT**

Radically unique from Stage to Studio, blending pre-EQ'd warmth and articulate punch.

**SHELL RECIPE:** EvenPly-Six Birch (4-ply outer), African Mahogany (2-ply inner).  
**SOUND:** Deep, rich bass frequencies. Top-end tonal spike.  
p. 24 - 25



**ROADSHOW**

A drum set package complete with everything needed to kickstart your rhythmic journey.

**SHELL RECIPE:** 9-ply 7mm Poplar.  
**SOUND:** Piercing, open cut with full sub-bass rumble.

p. 33



**e/MERGE**

A NEW SOUND. A NEW FEEL. AND, A COMPLETELY NEW E-DRUMMING EXPERIENCE.

p. 34 - 35

**DRUM SETS**

- 4-7 President Series
- 8-13 Masterworks
- 14-15 Reference
- 16-17 Reference Pure
- 18-19 Masters Maple Reserve
- 20-21 Masters Maple Gum
- 22-23 Masters Maple Complete
- 24-25 Session Studio Select
- 26-27 Crystal Beat
- 28-29 Decade Maple
- 30-31 Export / Export Lacquer
- 32 Midtown
- 32 Rocket Toms / Compact Traveler
- 33 Roadshow / Roadshow Jr.

**ELECTRONIC SERIES**

- 34-35 e/MERGE
- 36 MIMIC PRO
- 37 malletSTATION

**SNARE DRUMS**

- 38-39 President Series
- 38-39 Reference
- 40 Series Component
- 41 Free Floating
- 42 SensiTone Heritage Alloy
- 43 SensiTone Premium
- 44-45 Signature
- 46 Hybrid Exotic
- 47 Duoluxe
- 47 StaveCraft
- 48 Modern Utility
- 49 Utility & Effects

**HARDWARE**

- 50-51 Demon Drive / Chain
- 52-53 Eliminator Redline
- 54-55 Eliminator Solo
- 56-57 P930 / P932
- 57 P530 / P830
- 58-59 Hi-Hat Stands
- 60 Snare Stands
- 61 Drum Thrones
- 63 Cymbal Stands
- 64-66 Racks / Accessories
- 67 Tom Stands / Arms

**PERCUSSION**

- 68 Percussion Artists
- 69 Signature Series
- 70-71 Congas & Bongos
- 72 Travel Congas, Bongos, Timbales
- 73 Timbales / Cowbells
- 74 Djembes
- 75 Folkloric / Brazilian
- 76-77 Cajons & Accessories
- 77 Tongue Drums
- 78 Rainsticks / Nut Shakers
- 79 Concert Percussion
- 80-81 Hand Percussion
- 82 Percussion Stands
- 83 Bags, & Holders

84-87 Replacement Parts

88-91 Pearl Artists

92-BACK Config. & Color Chart

# PEARL BY THE NUMBERS

75TH ANNIVERSARY EDITION

## 4/2/1946

The day Katsumi Yanagisawa founded Pearl with two employees in a 300 sq. ft. factory in Sumida, Japan.



## 93

The total number of countries worldwide where Pearl products are sold.



## #1

Export, the number one selling drumset of all time. (pg. 36-37)



## 1,000,000

Pearl sold its one-millionth Export drum in 1995.

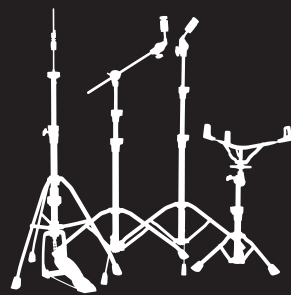

## 570

Number of tons of zinc used each year to make Pearl hardware.

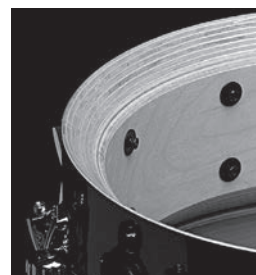

## 25

25mm - The thickness of a Pearl 20 ply Reference Series snare drum.



## 234

The total number of snare drum models offered by Pearl worldwide. (pg. 44-57)



## 8

Individual patents on the Eliminator bass drum pedal. (pg. 60-61)



## 658

The number of drum finishes Pearl has offered over the last two decades.



## 51 Reference

The number of steps in the painting process for Pearl Reference Series Sparkle finishes. (pg. 14-15)

# 1989

The year Pearl introduced the slogan,  
The best reason to play drums.

## 9042

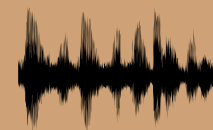

Average number of drum and cymbal samples used in a single kit in Mimic Pro.



## 66,972

Number of drum samples in the Mimic Pro module. (pg. 42)

## 200°F

Pearl's Superior Shell Technology cooks the glue into the shell at a temperature of 200 degrees.



## 1130

The number of cubic meters of sustainable wood used each year by Pearl to build drums would fill 19 train cars.



## 17,712

With Commander James Wetherbee, this Pearl drum key traveled at a max speed of 17,712 MPH and reached a maximum altitude of 244 miles aboard the U.S. Space Shuttle ATLANTIS in September 1997.



## 1,879,531

The total number of miles (in an average year) Pearl Drums travel by truck, train, and ship from our factories to Nashville.

## 1983

The year the Garfield Cadets, under the percussion direction of Thom Hannum, scored the only perfect drum score in the history of DCI.



## 37,691

The total number of products available from all Pearl factories.

## 3/22/2007



The day Pearl joined social media, leading to over 1.6 million followers across all Pearl profiles today.

# Masterworks

## 249,194,880,000

The number of possible Masterworks recipes based on current options. (pg. 8-13)

# 75

**Pearl**  
CELEBRATING SEVENTY-FIVE YEARS

**75**  
YEARS

**900**  
MONTHS

**27,394**  
DAYS

**657,456**  
HOURS

**39,447,360**  
SECONDS



...Devoted to Total Customer Satisfaction

# PRESIDENT SERIES PHENOLIC

A TRULY HISTORIC ORIGINAL WITH IMMACULATE VINTAGE STYLE

## CERTIFICATE OF AUTHENTICITY

Each President Series Phenolic drum kit comes standard with the Certificate of Authenticity.

**75** *Pearl*  
CELEBRATING  
SEVENTY-FIVE  
YEARS



PRESIDENT SERIES PHENOLIC KIT  
IN #452 PEARL WHITE OYSTER  
PSP923PX/C

Few "vintage" instruments have the rare presence of Pearl's original professional drum set: the President Series. Introduced in 1966, President Series was the first drum set to utilize the unique benefits of hermetically pressurized Phenolic shells.

In celebration of Pearl's history of quality and craftsmanship, President Series Phenolic shells make a triumphant return in a Limited Edition, 75th Anniversary drum set. Exuding pristine vintage style with focused updated function, President

Series Phenolic drums feature the tonal articulation and feel of the original with a modern-classic retool.

Special appointments include our original "Battleship" lug, adjustable internal tone mufflers, classic felt bass drum muffling strip, bass drum shell-mounted cymbal holder, and adjustable "Gullwing" style bass drum spurs. Pearl's elegant script badge and classic bass drum logo add to its old school swagger.

<b>SHELL</b>	Phenolic BD: 4.5mm, TT/FT/SD: 4mm
<b>SNARE</b>	14" x 5.5" (Sold Separately)
<b>FINISH</b>	Wrap finish #452 Pearl White Oyster
<b>HEADS</b>	Remo USA Coated Ambassador Top/ Bottom, Powerstroke 3 Coated Bass Drum (Batter) Anniversary Ed. Smooth White Coated Ambassador w/ Classic Pearl Logo
<b>SPURS</b>	BSP-835 "Gullwing" Style
<b>BD CYMBAL MOUNT</b>	CHB-75LB
<b>HOOPS</b>	SuperHoop II 2.3mm Triple-Flanged
<b>LUGS</b>	BSL-100 / BSL-200 / BSL-55
<b>BD MUFLER</b>	BDM-F and Resonant Felt Strip



### SHELLS

Hermetically Pressurized (4/4.5mm) Phenolic. A uniquely thin, thermo-layered solid shell that projects with uniquely cutting clarity from the strike, decaying quickly with even midrange spread.



### BEARING EDGE

Rounded 45° - Increased head-to-shell contact boosts mids and highs and helps control overtone spread.



### HARDWARE

2.3mm SuperHoop II Hoops - Made to maintain tuning integrity in heavy play while delivering maximum shell resonance.



### BSL LUGS

Cast in 1969 as "C-043" for Pearl's professional outfits, it has since been dubbed "The Battleship Lug" by collectors for its angular profile. The new BSL-L100 features the same striking look and self-aligning design with a more robust casting for better tuning integrity.

# PRESIDENT SERIES DELUXE

A MODERN REVIVAL OF THE DARKLY UNIQUE LAUAN SOUND



PRESIDENT SERIES DELUXE KIT  
IN #767 OCEAN RIPPLE  
PSD903XP/C



PRESIDENT SERIES DELUXE KIT  
IN #768 DESERT RIPPLE  
PSD923XP/C

## PEARL

A modern take on a familiar favorite, President Series Deluxe drums revive our original 6-ply Lauan shell, the source of the original "MIJ" (Made in Japan) sound. This darker toned medium/hardwood was the basis of thousands of shells made by Mitsuo Yanagisawa in Pearl's Chiba, Japan-based drum factory starting in 1961.

Presenting prime vintage style without the shortcomings of yesterday's fittings, President Series Deluxe features a recasting of our classic "Battleship" lug

and adjustable tone mufflers on each drum. The elegant identity of Pearl's original script badge and classic bass drum logo augment the swirling flash of a choice of our new Ripple covered finishes.

Each President Series Deluxe drum kit comes standard with Remo CS "Black Dot" UT heads, classic felt bass drum muffling strip, shell-mounted cymbal holder, and adjustable "Gullwing" style bass drum spurs.

<b>SHELL</b>	6-ply 7.5mm Lauan
<b>SNARE</b>	14" x 5.5" (Sold Separately) Wrap finishes
<b>FINISH</b>	#767 Ocean Ripple / #768 Desert Ripple #450 Silver Sparkle
<b>HEADS</b>	Remo UT CS Black Dot Batters Smooth White Coated Ambassador w/ classic Pearl Logo
<b>SPURS</b>	BSP-835 "Gullwing" Style
<b>BD CYMBAL MOUNT</b>	CHB-75LB
<b>HOOPS</b>	SuperHoop II 2.3mm Triple-Flanged
<b>LUGS</b>	BSL-100 / BSL-200 / BSL-55
<b>BD MUFFLER</b>	BDM-F and Resonant Felt Strip

Drawing from the very origins of Pearl's drum manufacturing history, President Deluxe Series revives the warm subtlety of our original tone wood for a traditionally full, controlled playing experience.



### SHELLS

6-ply 7.5mm Lauan. Loud yet subdued with deep, punchy wallop and plenty of top-end attack.



### BEARING EDGE

Rounded 45° - Increased head-to-shell contact boosts mids and highs and helps control overtone spread.



### HARDWARE

2.3mm SuperHoop II Hoops - Made to maintain tuning integrity in heavy play while delivering maximum shell resonance.



### BSL LUGS

Cast in 1969 as "C-043" for Pearl's professional outfits, it has since been dubbed "The Battleship Lug" by collectors for its angular profile. The new BSL-100 features the same striking look and self-aligning design with a more robust casting for better tuning integrity.

# MASTERWORKS

COMPLETELY CUSTOM, TOTALLY HANDMADE

## HANDCRAFTED TO INSPIRE

A Masterworks drum set is a timeless expression; custom tailored with heirloom precision to elevate your drumming persona, and fully reflect your musical identity.

## DRUMMING WITHOUT LIMITS

Selecting the right combination of our finest hand selected shell veneers with the precision engineering of our premium hardware appointments, Masterworks gives you the freedom to customize a sound that is completely your own.



MASTERWORKS CUSTOM KIT IN GLOSS NATURAL ARTISAN SYCAMORE FINISH W/EBONY INLAY AND BLACK NICKEL-PLATED HARDWARE

## DRUM SHELL TONE WOODS

Each of our premium shell materials has its own sonic signature that greatly affects the overall sound of each drum.



**MAPLE**  
*The perfect blend of tone, attack, and body.*  
Equal tonal amounts of highs, mids, and lows.



**BIRCH**  
*"Built-in EQ" delivers articulate stroke with shorter, even decay.*  
Boosted highs and mellow mid-level tone.



**AFRICAN MAHOGANY**  
*Deep, powerful punch with dark, elegant tone.*  
Bottom end emphasis with beautifully smooth midrange sustain.



**GUMWOOD**  
*Explosive projection and increased volume.*  
As a core or interior ply, Gum enhances tone in surrounding plies.



**CUSTOM INTERIOR**  
*The Ultimate Hybrid.*  
Choose any of Pearl's Artisan Exotic exterior hardwoods, hand applied carbon fiber, or a thin layer fiberglass for boutique tones and visuals.

## SHELL SIZE AND THICKNESS

For precise tonal character, sustain, and projection.



**THIN (4-ply, 5mm w/4-ply Reinforcement Rings)** Increased sustain and low-end.

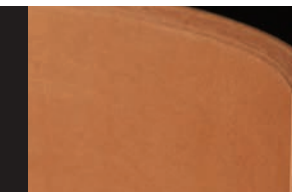

**MEDIUM (EvenPly-6, 5.4mm)** Expanded tonal purity and resonant punch.

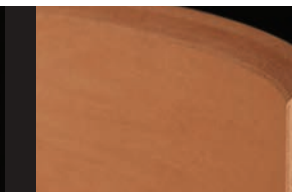

**STANDARD (6-ply, 7.5mm)** Full-bodied tonal projection ideal for general purpose.

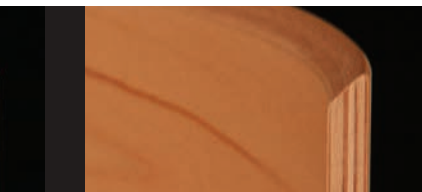

**THICK (8-ply, 10mm and 10-ply, 12.5mm)** Maximum projection and quick decay.

## FINISHES

**CRAFT** a personalized visual statement with drums hand finished and configured to your specifications.

**LUXURY** - Includes a choice of High Gloss, Satin Stain, and Sparkle Lacquer.

**CUSTOM** - Includes Pinstriping, Banding, Artisan II Custom Graphics.

**ARTISAN** - Choose from a selection of Exotic veneers (below) or hand applied Carbonply.



CAMEROON BLACK LIMBA

FLAME MAPLE

AFRICAN ZEBRA WOOD

TAMU ASH

WATERFALL BUBINGA

EUCALYPTUS

BURL MAHOGANY

IMBUIA

CARBONPLY

SYCAMORE w/EBONY INLAY

## BEARING EDGE

Masterworks offers a choice of five sonically tested edges - configurable by drum, application, and shell side.



**STANDARD 45°**  
Provides the perfect blend of attack and warmth.



**OUTER 60°**  
Pulls brighter overtones and increases punch.



**INNER 45°** Edge apex focused to inner shell plies for controlled sustain.



**ROUNDED 45°** Increased head-to-shell contact boosts mids and highs.



**FULLY ROUNDED**  
Boosts mid-to-low range response and reduces decay.

Choose from five gorgeous plating options on your selection of our precision tuning lugs, hoops, and drum hardware.

## HARDWARE FINISH, LUG, AND HOOP OPTIONS

### LUGS

- Bridge (CL-100)
- Single Swivel (STL-100)
- Swivel Tube (STL-150)
- Swivel Arch (BRL-100)

### FINISHES



**CHROME** (Shown w/ CL-100 Lug)



**NICKEL** (Shown w/ STL-100 Lug)



**GOLD** (Shown w/ STL-150 Lug)



**BLACK CHROME** (Shown w/ BRL-100 Lug)



**BLACK NICKEL** (Shown w/ STL-150 Lug)

### HOOPS



**MASTERCAST DIE-CAST**



**2.3MM SUPERHOOP II**

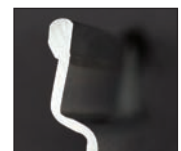

**1.6MM FATTONE**

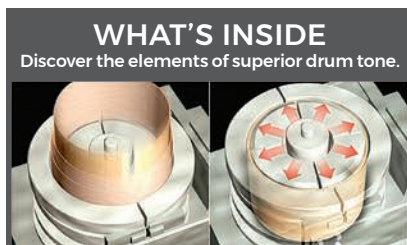

## WHAT'S INSIDE

Discover the elements of superior drum tone.



THE **EST** DIFFERENCE - The Ultimate in Strength, Resonance, and Tone.

Using the world's first high temperature hydraulic curing system, the SST method was developed to craft a multi-ply, bonded drum shell with single-ply resonance and strength.

All shells are formed in a bonded combination of cross-laminated 2-ply veneer panels; precision milled with overlapping scarf joint seams and cured with our exclusive AcoustiGlue at 1000 PSI of hydraulic pressure.

# MASTERWORKS

SONIC-SELECT SHELL RECIPE



## THE MASTERWORKS EVOLUTION CLEARLY DEFINED BY PERFORMANCE APPLICATION.

Five distinct drum recipes; each one a combination of sonically proven shell woods, edge profiles, and precision hardware options. Crafted to create a truly unique tonal signature.

### URBAN (pgs. 10 - 11)

A thin, powerful blend for the precise metropolitan drummer.

### STADIUM (pg. 12)

Pearl's thick CZX Maple shell for high-volume power.

### STUDIO (pg. 12)

Explosive tonal clarity and articulation for recording.

### HERITAGE (pg. 13)

Classic drum feel with enhanced lows and fat top-end slap.

### MODERN DRY (pg. 13)

Quick, top-heavy articulation with controlled low-end.



<b>SHELL</b>	EvenPly-Six (5.4mm Toms/Bass) 2-Birch/2-Gumwood/2-Birch with 4-ply Maple Re-Rings 8-ply Snare Drums 2-Birch/4-Gumwood/2-Birch
<b>BEARING EDGE</b>	Rounded 45° on Toms Fully Rounded edge on bass drums Standard 45° on snare drums
<b>HOOPS</b>	2.3mm SuperHoop II
<b>LUGS</b>	STL Swivel Tube Lugs STL-150 (Toms) STL-300 (Bass Drum)
<b>SPURS</b>	SP-300 w/ Retractable Spike
<b>FLOOR TOM BRACKETS</b>	LB-200

## Masterworks Sonic-Select Urban Recipe

### A NEW BREED OF HIGH END DRUMS FOR THE METROPOLITAN PLAYER.

From sold out tours to sanctuary halls, the Sonic-Select Urban formula projects with a defiant top end and fills the bass frequencies with thunderous, shaking lows.

MASTERWORKS SONIC SELECT URBAN KIT IN GLOSS BLACKBURST ARTISAN SYCAMORE FINISH WITH BLACK NICKEL-PLATED HARDWARE (configured w/ MASTERCASHT HOOPS)



**SHELL**  
Dense, thin shell hybrid for precise punch and quick, even decay.



**BEARING EDGE**  
Rounded 45° on Toms (Fully Rounded edge on bass drums, Standard 45° on snare drums)



**HARDWARE**  
2.3mm SuperHoop II Hoops - Made for heavy play without limiting tuning range performance.



**LUGS**  
A medium-weight lug with pivoting tension casing for increased projection and reduced overtone. STL-150 / 300



**MAKE MASTERWORKS COMPLETELY YOUR OWN**

Turning the drum kit into a blank canvas, Masterworks Sonic Select Shell Recipes can be customized to fit your own vision. Modify any shell or hardware option to give it your own spin, or use our exclusive Artisan II process to embed your choice of high-def graphics directly onto the outer shell.

**Masterworks Sonic-Select Stadium Recipe**



MASTERWORKS SONIC SELECT STADIUM KIT IN GLOSS WHITE GOLD DUST LACQUER FINISH WITH GOLD-PLATED HARDWARE (configured w/ FATTONE HOOPS)

**THE CZX SOLUTION FOR HIGH VOLUME, RHYTHMIC COMMAND.**

This high density shell and hardware recipe is a modern interpretation of Pearl's legendary CZX (or Zenithal Resonator) Maple shell. Stadium's thick shell for dominates volume and articulates attack. Its 10-ply/8-ply combination projects with full bodied midrange and focused low end.

<b>SHELL</b>	10-ply Maple BD, 10-ply Maple FT, 8-ply Maple Toms and Snares
<b>BEARING EDGE</b>	Outer 60° For increased power and controlled overtone
<b>HOOPS</b>	2.3mm SuperHoop II
<b>LUGS</b>	Swivel Bridge Lugs to maintain attack and tuning integrity. BRL-100 (Toms) BRL-300 (BD)
<b>SPURS</b>	SP-300 w/ Retractable Spike
<b>FLOOR TOM BRACKETS</b>	LB-200



**SHELL**  
A thick shell for dominating volume and articulate attack.



**BEARING EDGE**  
Outer 60° Increases brightness and power with controlled overtone.



**HOOPS**  
2.3mm SuperHoop II Hoops - Made to withstand heavy play while allowing the shell to breathe.



**LUGS**  
Heavier weight increases attack and assures the ultimate in tuning integrity.

**Masterworks Sonic-Select Studio Recipe**



MASTERWORKS SONIC-SELECT STUDIO KIT IN TRANSPARENT PRUSSIAN BLUEBURST OVER ARTISAN FLAME MAPLE WITH NATURAL STRIPE AND NICKEL PLATED HARDWARE

**A POWERFUL SONIC FOUNDATION TUNED FOR THE RECORDING ENVIRONMENT.**

The Studio Recipe's commanding hardware/shell combination delivers explosive projection in the midrange for clean tonality and extended low end punch. Its thin, historically proven shell combination of a hard exterior with milder tonewood crafts explosive low range warmth.

<b>SHELL</b>	EvenPly-6 (5.4mm), 4-ply Maple Outer with 2-ply Gumwood Inner
<b>BEARING EDGE</b>	Outer 60° Gives increased power and bite to a thinner hybrid shell
<b>HOOPS</b>	MasterCast Hoops
<b>LUGS</b>	CL Bridge Lug CL-100 (Toms) CL-250 (Bass Drum)
<b>SPURS</b>	SP-300 w/ Retractable Spike
<b>FLOOR TOM BRACKETS</b>	LB-200



**SHELL**  
Thin, resonant combination of a hard exterior with milder tonewood for explosive low-range warmth.



**BEARING EDGE**  
Outer 60° Gives increased power and bite to a thinner hybrid shell.



**HOOPS**  
MasterCast Hoops. Escalates weight for tonal body. Increases volume in high velocity play.



**LUGS**  
CL Bridge Lug  
A classic look with minimal shell contact for precise vibration control.

**Masterworks Sonic-Select Heritage Recipe**



MASTERWORKS SONIC-SELECT RECIPE: HERITAGE KIT IN SATIN OLIVEBURST LACQUER WITH A2 ROSARY BANDS (BY ILLUSTRATOR JESSICA HANCOCK) AND NICKEL-PLATED HARDWARE

**ORGANIC TONE THAT PURRS LIKE THE GROWL OF A CLASSIC ROADSTER.**

The Sonic-Select Heritage Recipe's traditional blend of reinforced Maple/Mahogany delivers a midrange punch with solid low end boost. This robust combination produces thunderous sub bass frequencies with exceptional sustain and subtle projection.

<b>SHELL</b>	4-ply Maple (2-ply outer) Mahogany (2-ply inner) w/ 4-ply Maple Re-Rings
<b>BEARING EDGE</b>	Standard 45° Low contact edge for added projection and resonance.
<b>HOOPS</b>	1.6mm FatTone
<b>LUGS</b>	STL-100 (Toms) STL-200 (Bass Drum)
<b>SPURS</b>	SP-300 w/ Retractable Spike
<b>FLOOR TOM BRACKETS</b>	LB-200



**SHELL**  
A traditional blend of midrange punch and boosted low-end.



**BEARING EDGE**  
Standard 45° - Precise, low-contact edge for added projection and resonance.



**HARDWARE**  
FatTone Hoops - The light, rigid design of its exclusive hemmed edge increases resonance and tuning stability.



**LUGS**  
Our lightest and most efficient tuning lug reduces hardware contact and weight on the shell.

**Masterworks Sonic-Select Modern Dry Recipe**



MASTERWORKS SONIC SELECT MODERN DRY KIT IN KOBALT BLUE FADE METALLIC LACQUER FINISH WITH BLACK NICKEL-PLATED HARDWARE

**DARKLY ORGANIC PUNCH FOR DRIVING, ORGANIC BEAT MAKING.**

The Modern Dry Recipe blends three sonically unique tone woods for dark, controlled tone, and pillowy response. Its unique blend of shell and hardware elements adds bottom end focus and throaty punch.

<b>SHELL</b>	2-ply Maple outer/2-ply Gumwood inner with 4 ply Mahogany Re-Rings
<b>BEARING EDGE</b>	Inner 45° For focused control in low tunings.
<b>HOOPS</b>	MasterCast Hoops
<b>LUGS</b>	Single Swivel Lugs STL-100 (Toms) STL-200 (BD)
<b>SPURS</b>	SP-300 w/ Retractable Spike
<b>FLOOR TOM BRACKETS</b>	LB-200

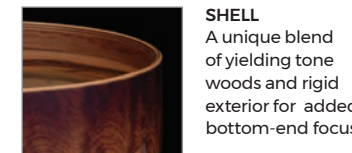

**SHELL**  
A unique blend of yielding tone woods and rigid exterior for added bottom-end focus.



**BEARING EDGE**  
Inner 45° - Its inner shell apex contacts the head inside the shoulder for focused control in low tunings.



**HOOPS**  
MasterCast Hoops - Gives each drum added weight for increased volume and controlled sustain.



**LUGS**  
Single Swivel Lugs  
Our lightest and most efficient tuning lug for reduced shell contact. STL-100/200



# REFERENCE

SONICALLY SELECT DRUM PERFORMANCE

# Reference

## SONICALLY PROVEN SHELL PERFORMANCE

Utilizing the nearly limitless selection of materials and options from our Masterworks Custom Shop, each Reference tom, snare, and bass drum is individually-optimized with its own shell, hardware, and edge "Recipe" to best capture its intended voice.

Just as single notes combine to make a piano, the total Reference kit's singular, unified voice perfectly captures every nuance of your unique drumming ideal.



#839  
Redburst Triband



#832  
Sapphire Blue Sparkle with Black Nickel Hardware

<b>SHELL</b>	Maple, Birch & African Mahogany
<b>SNARE</b>	20 Ply Matching 13 x 6.5, 14 x 5 or 14 x 6.5"
<b>FINISH</b>	Premium lacquer / Wrap finishes
<b>HEADS</b>	Remo Clear Emperor Tom, Powerstroke3 Bass
<b>TOM MOUNTS</b>	Aluminum OptiMount Suspension System
<b>TOM ARMS</b>	Sold Separately
<b>HARDWARE</b>	Chrome (Standard) Nickel, Black, Black Nickel, and Gold**
<b>HOOPS</b>	MasterCast Die-Cast Hoops
<b>LUGS</b>	BRL Bridge Lugs with Swivel Function

## SHELLS

Individually engineered for power, tone, and distinction, the total Reference kit perfectly captures every nuance of your unique drumming identity with a singular, prestigious sound.



## HARDWARE

**MASTERCAST HOOPS** enhance the overall weight and volume of each shell and stay true under constant play.

**BRL SWIVEL LUGS** feature pivoting internal brass tension casings to assure tuning integrity and reduce shell stress.



## SP-300 SPUR

Pearl's SP-300 bass drum spur features retractable high grip rubber tip and recessed spike for high impact, slip free play.

## REFERENCE RECIPE

8" and 10" Toms	
12" Toms	
13" Toms	
14" and 15" Toms	
16" Toms	
14" Floor Toms	
16" and 18" Floor Toms	
18" and 20" Bass Drums	
22", 24", 26" Bass Drums	

## SHELL TYPE

<b>Maple(4)/Birch(2)</b> 6-ply (RF 7.5mm / RFP 5.4mm)
<b>Maple(6)</b> 6-ply (RF 7.5mm / RFP 5.4mm)
<b>Maple(4)/Mahogany(2)</b> 6-ply (RF 7.5mm / RFP 5.4 mm)
<b>Maple(4)/Mahogany(2)</b> 6-ply (RF 7.5mm / RFP 5.4 mm)
<b>Maple(2)/Mahogany(4)</b> 6-ply (RF 7.5mm / RFP 5.4mm)
<b>Maple(4)/Mahogany(4)</b> 8-ply (RF 10mm / RFP 7.2mm)
<b>Maple(2)/Mahogany(6)</b> 8-ply (RF 10mm / RFP 7.2mm)
<b>Maple(2)/Mahogany(4)</b> 6-ply (RF 7.5mm / RFP 5.4mm)
<b>Maple(2)/Mahogany(6)</b> 8-ply (RF 10mm / RFP 7.2mm)

## BEARING EDGE

Rounded 45°
Rounded 45°
Rounded 45°
Fully Rounded
Fully Rounded
Fully Rounded
Fully Rounded
Fully Rounded
Fully Rounded

## SONIC OUTPUT

Cutting projection for high-note pitch
Transitional mid-note; blend of warmth and cut
Top-end slap with added low/bottom end
Bracing low-end with controlled punch
Full, rounded sustain and gated attack
Fat, controlled low-end with smooth roll-off
Fat, controlled low-end with resonant warmth
Quick and Punchy with Powerful low-end
Booming bass tone with articulate punch

# REFERENCE PURE

UNRESTRICTED TONAL RESPONSE

*Reference*  
PURE

**THE EVENPLY DIFFERENCE** lies in thinner shell layers. Using the same hybrid wood composition as the Reference Recipe with thinner plies gives the Reference Pure shell a lean profile with increased strength. Combining the ultra thin EvenPly shell with more efficient shell hardware reduces overall drum weight by 30% for increased resonance, improved bottom end, and a more nuanced near field playing experience.



#834  
Glacier Blue Sparkle



### SNARE DRUMS

A thin EvenPly-6 shell with four outer Maple and two inner Birch plies for cut, projection, and smooth, balanced sound. 45° bearing edges provide superbly articulate sensitivity.

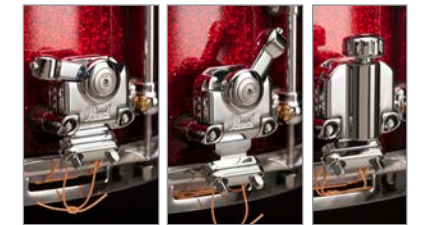

### SR-1000

SR-1000 Glide-Lock Strainer's locking throw off lever and tension knob assures slip-free performance. (U.S. Patent #7220905, #7301087, #7365256)



#844  
Satin Rose Gold with Nickel Hardware

### HARDWARE



**1.6MM FATTONE HOOPS'** exclusive hemmed/welded edge (U.S. Pat. #8367917) gives increased strength to low mass design.



**STL SWIVEL TUBE LUGS** allow for increased resonance, minimal shell contact, and precisely aligned, no bind tuning.

<b>SHELL</b>	Low Mass Evenply Maple, Birch & African Mahogany
<b>SNARE</b>	6 Ply Matching 13 x 6.5, 14 x 5, 14 x 6.5 (Sold Separately)
<b>FINISH</b>	Premium Lacquer / Wrap finishes
<b>HEADS</b>	Remo Clear Emperor Tom, Powerstroke3 Bass
<b>TOM MOUNTS</b>	Aluminum OptiMount Suspension System
<b>TOM ARMS</b>	Sold Separately
<b>HARDWARE</b>	Chrome, Nickel, Black, Black Chrome Plated, or Gold Plated
<b>HOOPS</b>	Low Mass FatTone Hoops
<b>LUGS</b>	Low Mass STL Swivel Tube Lugs

### SHELLS

Boasting the same shell construction that made Reference drums a professional standard, Reference Pure's uninhibited, shell-focused tonality excels in any playing environment.



### OPTIMOUNT

Aluminum Tom Mounts suspend the drum evenly across four tension points to allow resistance-free resonance in play.



### AIR SUSPENSION RUBBER TIP

(U.S. Patent #5881981) isolates the tom from the floor, preventing tonal choke and increasing resonance.



### GOLDEN RATIO AIR VENT

(U.S. Patent #7485791) is precision placed in the Fibonacci Spiral on toms to increase low-end response.

# MASTERS MAPLE RESERVE

A CLASSIC FORMULA FOR SONIC GREATNESS

*Masters*  
MAPLE RESERVE



#355  
Antique Walnut

## THE MASTERS LEGACY

Delivering arguably the greatest drum tones ever recorded, Pearl's fresh take on the legendary Maple/Gum shell recipe reaches new levels in dynamic sonic warmth and explosive low-end response.

Now, Pearl expands Masters Maple/Gum with updated finish and component options; making our first production Masterworks kit a true prize for the owner.



#359  
Twilight Burst

Masters Maple Reserve is available in all Premium Lacquer / Wrap finishes  
see Page 92. & Back Cover.



<b>SHELL</b>	4-ply (5mm) 100% Maple w/ 4-ply Maple Re-Rings
<b>SNARE</b>	Matching 14x5.5 or 14x6.5 (Sold Separately)
<b>FINISH</b>	Premium lacquer / Wrap finishes
<b>HEADS</b>	Coated/Ported Powerstroke3 Bass (Front) Clear Powerstroke3 (Batter)
<b>TOM MOUNTS</b>	Aluminum OptiMount Suspension System
<b>HARDWARE</b>	Chrome, Nickel, Black, Black Nickel
<b>HOOPS</b>	Low Mass FatTone Hoops
<b>LUGS</b>	CL Bridge Lugs
<b>BD MUFFLER</b>	BDM-F (Full Size)

## SHELLS

4-ply Maple shell with 4-ply Maple Reinforcement Rings. A classic shell fusion delivering rich, sustained lows and controlled sonic punch.



## HARDWARE



### ALUMINUM OPTIMOUNT SUSPENSION SYSTEM

Light and efficient four-point contact design delivers secure tom mounting without penetrating the shell.



### HARDWARE

FatTone Hoops - Rigid 1.6mm hemmed/welded edge extends sustain with punchy projection.



### BEARING EDGE

Standard 45°

### CL BRIDGE LUGS

A classic lug with a minimal contact arc for precise vibration control.

**MASTERS MAPLE / GUM**  
THE EVOLUTION OF PREMIUM STUDIO TONE

*Masters*  
MAPLE/GUM

**THE MASTERWORKS STUDIO RECIPE, SIMPLIFIED.**

Delivering arguably the greatest drum tones ever recorded, Pearl's fresh take on the legendary Maple/Gum shell recipe reaches new levels in dynamic sonic warmth and explosive low-end response.

Now, Pearl expands Masters Maple/Gum with updated finish and component options, making our first production Masterworks kit a true prize for the owner.



#186  
Hand Rubbed Natural Maple

#187  
White Silver Swirl with matching 14"x14"  
Floor Tom and matching  
Havana Series Congas and Bongos

Masters Maple Gum is available in all Premium Lacquer / Wrap finishes  
see Page 92. & Back Cover.



<b>SHELL</b>	EvenPly Six (6-ply, 5.4mm) North American Maple/Gum
<b>FINISH</b>	Pearl Pre-jum Lacquer, Hand-Rubbed Natural Wax or Premium USA Wrap
<b>HEADS</b>	Remo Coated Ambassador, Powerstroke3 Bass
<b>TOM MOUNTS</b>	Aluminum OptiMount Suspension System
<b>HARDWARE</b>	Chrome
<b>HOOPS</b>	MasterCast Die-Cast Hoops
<b>LUGS</b>	CL Bridge Lugs

**SHELLS**

EvenPly-6, 4-ply Maple outer with 2-ply Gumwood inside -The natural warmth of Maple is enhanced by Gumwood's dense, controlling character.



**HARDWARE**



**MASTERCAST HOOPS**  
Escalates weight for tonal body and increases volume in high velocity play.



**BEARING EDGE**  
Outer 60° - Gives increased power and bite to a thinner hybrid shell.



**CL BRIDGE LUGS**  
A classic look with minimal shell contact for precise vibration control.  
CL-100 / 250



# SESSION STUDIO SELECT

A COMPLETELY NEW TAKE ON THE FULL SPECTRUM SOUND

**A TRUE PEARL ORIGINAL,  
WITH A FRESH, GROOVE INSPIRING VIBE.**

Taking a tip from the Masterworks spectrum, Session Studio Select's unparalleled combination of Masters-grade Birch and African Mahogany deliver a refined standout for recording and gigging.



#314  
Gloss Barnwood Brown



#847  
Scarlet Ash

## FINISHES

### HIGH GLOSS LACQUER



#112  
Natural Birch



#314  
Gloss Barnwood Brown



#315  
Antique Crimson Burst



#316  
Black Halo Glitter



#847  
Scarlet Ash

### PREMIUM DELMAR WRAP



#405  
Nicotine White Marine Pearl



#414  
Ice Blue Oyster



#766  
Black Mirror Chrome

<b>SHELL</b>	EvenPly Six (6-ply, 5.4mm) Birch/African Mahogany
<b>SNARE</b>	14x5.5, 14x6.5, or 14x8 Matching Wood* (Sold Separately)
<b>FINISH</b>	Premium Wrapped or High Gloss Lacquer
<b>HEADS</b>	Remo Pinstripe Clear Tom, Powerstroke3 Bass, UT Coated Snare
<b>TOM MOUNTS</b>	OptiMount Suspension System
<b>TOM ARMS</b>	Sold Separately
<b>HARDWARE</b>	Chrome
<b>HOOPS</b>	SuperHoop II 2.3mm Triple Flanged
<b>LUGS</b>	RL Lugs

## SHELLS

EvenPly-Six Birch/African Mahogany. A unique sonic dichotomy of piercing projection, smooth low-end and pre-EQ'd punch.



## SESSION STUDIO SELECT

### PROFESSIONAL SOUND. CLASSIC VALUE.

The Session tradition of value for the drummer lives on with three specially priced shell packs, each including a FREE added floor tom.



### BEARING EDGE

Outer 60-Degree. Increases volume and punch without harsh overtones.



### HARDWARE

SuperHoop II, 2.3mm Triple-Flanged hoops for rigid tuning stability without robbing the shell of sustain.

# CRYSTAL BEAT

THE ORIGINAL SEAMLESS ACRYLIC DRUM SET



#731  
RUBY RED

WITH ADDED 22"x16" BASS DRUM (CRB2216BX/C)  
AND ADDED ROCKET TOMS IN #730 ULTRA CLEAR

# CRYSTAL BEAT



Originating in 1973, Pearl's Crystal Beat Acrylic drums feature a 7mm molded/seamless Acrylic shell for a vivid combination of cutting tonal power and stunning visual appeal.

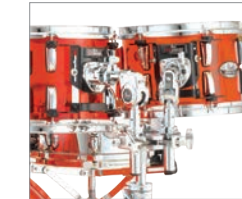

## HARDWARE

Toms include the OptiMount suspension system for increased sustain and 1.6mm triple-flanged hoops for attack and punchy tonal body.



#732 Tangerine Glass



#730 Ultra Clear

<b>SHELL</b>	6mm (7mm on Bass Drums) Seamless Molded Acrylic
<b>SNARE</b>	Matching Free Floater (Sold Separately)
<b>FINISH</b>	Transparent
<b>HEADS</b>	Transparent 2-Ply on Tom Batters Single-Ply Resonant
<b>TOM MOUNTS</b>	OptiMount Suspension System
<b>TOM ARMS</b>	Sold Separately
<b>HARDWARE</b>	Chrome
<b>HOOPS</b>	Chrome 1.6mm Triple-Flanged
<b>LUGS</b>	CB Mid-Lugs on Toms, CB Fat-Lugs on Bass

## SHELLS

Loud and immediate, delivers pummeling straight tone and yielding feel. Dual 45° bearing edge with a rounded apex, adding control and increased articulation to acrylic's sonic signature.



## FINISHES

Crystal Beat is available in a choice of four engaging colors, a host of sizes and set-ups, and even single-headed and Rocket tom options for a clearly striking drum statement.



#730  
Ultra Clear



#731  
Ruby Red



#732  
Tangerine Glass



#733  
Frost Acrylic

# DECADE MAPLE

A DRUM KIT 10 YEARS IN THE MAKING



#207  
Ultramarine Velvet

#225  
Classic Satin Amburst

## FINISHES



<b>SHELL</b>	Even Ply 6 (5.4mm) 100% Maple
<b>SNARE</b>	Matching 14x5.5
<b>FINISH</b>	High-Gloss / Matte Lacquer
<b>HEADS</b>	Remo UT Clear Ambassador Tom, Ported UT Powerstroke3 Bass
<b>TOM MOUNTS</b>	Opti-Loc Mounting System
<b>HARDWARE</b>	Chrome
<b>HOOPS</b>	1.6mm Steel Triple Flanged
<b>LUGS</b>	NDL Lugs
<b>BD MUFFLER</b>	BDM-M (Mini)

## SHELLS

6-ply/5.4mm Maple - Thin (but powerfully strong)  
Pearl's SST shell reacts quickly to the stroke with beautifully resonant highs and thundering lows.



# DECADE MAPLE

Built to push the boundaries of performance and price, Decade Maple Series drums elevate the playing field for the advancing drummer with pro features and unbeatable value.



## OPTI-LOC MOUNTING SYSTEM

This three-point isolation mount suspends the drum at two tuning points and one of the drum's air vents for solid, stable play.



## HARDWARE

Uni-Lock gearless Tom Arms.  
R-40 Air Suspension Floor Tom feet.  
NDL Mini Lugs:  
For reliable, rock solid durability and sound.



# EXPORT LACQUER

THE LEGENDS OF TOMORROW, PLAY EXPORT TODAY

The Export Series 30 year pedigree of unbeatable quality and value shines on with Reference-inspired shell woods and high impact hardware, giving the rising player a truly high end playing platform.



#220  
Azure Daybreak



#49  
Mirror Chrome

**EXPORT**  
THE BEST SELLING DRUM SET OF ALL TIME

## EXL (Lacquer finishes.)

SHELL	6-Ply 7.5mm Birch/Poplar/Asian Mahogany Blend
SNARE	14 x 5.5 Matching Wood Snare
FINISH	Choice of 6 High Gloss Lacquer Finishes and 5 Satin Finish
HEADS	Remo Clear Tom Head, Powerstroke Bass Head
TOM MOUNTS	Opti-Loc Mounting System
TOM ARMS	TH-70I
DRUM HARDWARE	Chrome
HARDWARE	P-930, BC-830, C-830, H-830, S-830
BD MUFFLER	BDM-M (Mini)



#211 Azure Daybreak #217 Raspberry Sunset #218 Ember Dawn #219 Indigo Night



#220 Satin Brown #222 Gloss Tobacco Burst #246 Natural Cherry #248 Black Smoke #249 Honey Amber #255 Nightshade Lacquer #257 Sea Blue Fade

## EXX (Wrapped finishes.)

SHELL	6-Ply 7.5mm Poplar/Asian Mahogany Blend
SNARE	14 x 5.5 Matching Wood Snare
FINISH	Choice of 9 Covered Finishes
HEADS	Remo Clear Tom Head, Powerstroke Bass Head
TOM MOUNTS	Opti-Loc Mounting System
TOM ARMS	TH-70I
DRUM HARDWARE	Chrome
HARDWARE	P-930, BC-830, C-830, H-830, S-830
BD MUFFLER	BDM-M (Mini)



#21 Smokey Chrome #31 Jet Black #33 Pure White #49 Mirror Chrome



#708 Grindstone Sparkle #717 High Voltage Blue #735 Satin White #760 Burgundy #761 Satin Shadow Black

## SHELLS

6-ply / 7.5mm Poplar/Asian Mahogany. A Pearl SST (Superior Shell Technology) blend for high volume resonance and sustained low-end punch.



## 830 SERIES HARDWARE

Sophisticated, sturdy, and efficient, Export's 830 Series Boom (BC-830), Cymbal (C-830), and Snare (S-830) stands all feature gearless Uni-Lock Tilters for pinpoint positioning, and robust double-braced tripods for secure stability in play. The H-830 Hi-Hat stand also features swivel legs that accommodate double pedals.



Drum Pedal  
P-930

## P-930 PEDAL

Featuring the longboard styling and feel of Pearl's Demon Drive pedal, the P-930 offers two chain drive cam options for power, speed, and control.

## OPTI-LOC MOUNTING SYSTEM

Pearl's three way tom mount delivers wobble free stability by suspending the drum at two tuning points and one of the drum's two air vents.



# MIDTOWN

BIG GIG, SMALL RIG, HUGE SOUND



#701 Black Gold Sparkle  
MDT764P/C

## SHELLS



6 Ply (7.5 mm) Poplar. Quick and biting attack with lively overtones.

## CONFIGURATIONS

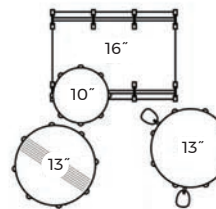

## FINISHES



## HARDWARE



Lift used on Midtown raises the drum to the optimal position for your pedal.

## SETTING THE PULSE FOR THE METROPOLITAN GROOVE

Pearl's ultra portable Midtown Kit is the perfect sounding board for full size sound and play in a smaller footprint. Ideal for tight gigging spaces on a budget.

<b>SHELL</b>	6 Ply (7.5 mm) Poplar
<b>SNARE</b>	Matching 13x5.5 Wood Snare Drum
<b>FINISH</b>	Choice of 2 Covered Finishes
<b>HEADS</b>	Remo UC Clear Tom Remo UC Clear Powerstroke Batter Bass Remo UC Coated Snare
<b>TOM ARMS</b>	TH-701
<b>HARDWARE</b>	Chrome

# ROCKET TOMS

For striking staccato tone that's both melodic and piercing, Pearl's Rocket Toms are 6" pitched toms in varying lengths made to expand the sonic palette of any drum kit.

Available in sets or as individual components in Aluminum. Finishes: #103 Piano Black, #109 Arctic White, or #730 Ultra Clear Acrylic, #731 Ruby Red, #732 Tangerine Glass.



AL612	6" x 12"
AL615	6" x 15"
AL618	6" x 18"
AL621	6" x 21"
ALX1215	6" x 12", 6" x 15" (w/ T-890)
ALX1821	6" x 18", 6" x 21" (w/ T-890)
CRB612/C	6" x 12"
CRB615/C	6" x 15"
CRB618/C	6" x 18"
CRB621/C	6" x 21"

# COMPACT TRAVELER

<b>BASS DRUM</b>	18" w/ Base Frame & L-Arm Handle
<b>SNARE</b>	10" w/ Adjustable Snare Rake
<b>STANDS</b>	Sold Separately
<b>CARRYING CASE</b>	PSC-PCTK (Sold Separately)
<b>ADD ON PACK</b>	PCTK-T1014 Includes 10" & 14" Toms w/ Mounting Hardware

Take the rhythm on the road with Pearl's totally portable, super playable, ultra affordable beat maker. Perfect for School, Street, Practice, and Stage.



Shown with PCTK-T1014 add on pack\* PCTK-1810

\*HW/Cymbals sold separately



Pedal sold separately PCTK-1810

Add on pack (10" & 14" toms w/ mounting hardware) PCTK-T1014

Optional Compact Traveler Bag PSC-PCTK

Optional Compact Traveler Add on Bag PSC-PCTKADD

# ROADSHOW JR.

Pearl's Roadshow Jr. is NOT a toy. It's a serious, all-in-one, five piece drum set sized for kids under 8-years-old featuring hardware, cymbals, and sturdy White Poplar shell construction for an exceptionally powerful drumming start.

Complete with Hardware, Cymbals, and Throne for Drummers under 8.

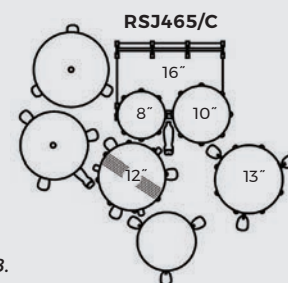

#31 Jet Black RSJ465/C

#708 Grindstone Sparkle RSJ465/C

# ROADSHOW

IT'S YOUR TIME TO PLAY, START THE RIGHT WAY!

## THE RHYTHM IS IN YOU

Drumming knows no age limit. Regardless of when your rhythmic journey starts, Pearl's Roadshow Series has a drum set package scaled for players of all ages that includes everything you need to get on the road to drumming greatness.



#707 Bronze Metallic RS525SC/C

<b>SHELL</b>	9 Ply 7mm Asian White Poplar
<b>SNARE</b>	Matching Wood Snare
<b>FINISH</b>	Choice of 6 Covered Finishes
<b>HEADS</b>	Clear Tom Heads, Coated Snare Head, Self-Muffled Bass Head
<b>TOM ARMS</b>	Individually Locking 7/8" Tube Joint Holders
<b>HARDWARE</b>	Dual-Chain Drive Bass Drum Pedal Double-Braced Cymbal*, Snare and Hi-Hat Stands, Double-Braced Throne
<b>CYMBALS</b>	16" Brass Cymbal, 14" Brass/Hybrid Hi-Hat Cymbals
<b>ACCESSORIES</b>	Pro Drum Stick Bag, Two pairs of Maple 5A Sticks

## THE HEART OF THE ROADSHOW SOUND.

Roadshow is crafted to be everything you'd expect from a Pearl Drum set, featuring a 9 ply Poplar shell for optimum tonal power.

## FINISHES



#706 Charcoal Metallic RS584C/C



NATE MORTON  
THE VOICE

For additional info, testimonials, free assembly and instructional videos, and access to the largest drummer's community on the web, go to:

[WWW.MYFIRSTDRUMSET.COM](http://WWW.MYFIRSTDRUMSET.COM)

**e/MERGE**  
POWERED BY KORG



e/TRADITIONAL CONFIGURATION

PUREtouch 10", 12" and 14" toms, a 14" snare, and PUREtouch Kick Pad. PUREtouch Cymbals, ICON e-Rack, MDL1 Module.  
**EM-53T**

The foundation of the e/MERGE electronic drum set is a custom designed, chrome plated ICON e-Rack system.



e/HYBRID CONFIGURATION

PUREtouch 10", 12" and 14" toms, a 14" snare, and 18" acoustic bass drum. PUREtouch Cymbals, ICON e-Rack, MDL1 Module.  
**EM-53HB**

**e/MERGE**

**NOT JUST A NEW STANDARD.**

A NEW SOUND. A NEW FEEL. AND, A COMPLETELY NEW E-DRUMMING EXPERIENCE.

**e/MERGE** is about change, and change in the e-drum market has been way overdue. When we looked closely at every aspect of the current e-drumming experience with KORG, together we knew we could make a dramatic difference. And that difference begins with the all new e/MERGE module. Simple yet elegant in design, the e/MERGE MDL1 module features a full library of high definition, natural, organic and minimally processed acoustic Pearl drums. We then added the very best electronic, world, orchestral and specialty percussion sounds from KORG's vast library of pristine quality samples. But, the module is only part of the change.

There are three key elements that separate e/MERGE from anything that has come before. The all new MDL1 e/MERGE Module, KORG's amazing WAVE TRIGGER TECHNOLOGY and Pearl's acoustic-like PUREtouch electronic pads and cymbals combine to create an exceptional e-drumming experience.

**e/MERGE MDL-1 MODULE** Simple, straight forward yet extremely powerful, the MDL1 module offers, a pair of powerful multicore processors, a full library of acoustic Pearl drums recorded in one of the world's most renowned studios, pristine samples from KORG's library and the variety of routing options every e-drummer needs.



**WAVE TRIGGER TECHNOLOGY** This ultra-fast and highly sensitive technology partially based upon KORG's groundbreaking Wave Drum allows even your stick choice to make a discernible difference in the sound of your drum.



**PUREtouch PADS & CYMBALS**

Perfectly sized pads designed to replicate the ultimate acoustic-like response. PUREtouch features layer upon layer of specially designed materials each selected for a specific quality that together create an e-experience never before possible.

(PUREtouch Pads U.S. Patent #10475424)  
(PUREtouch Hi-Hats U.S. Patents #10475430, 10482855)



**MODULE SPECIFICATIONS**

SOUND GENERATOR	2 CPU (4 core + 2 core)
POLYPHONY	128 Voices
VOICE	700 HD Sound Library
DRUM KIT	35 HD Kits
EFFECTS	36
SONG RECORDING TYPE	44.1kHz, 16 Bit WAV
SONG RECORDING TIME	Approximately 12 Hours
CLICK TEMPO	BPM 30 - 300
BEAT	1/2 - 24/2, 1/4 - 24/4, 1/8 - 24/8, 1 - 24/8T, 1/16 - 24/16 (T=Triplet)
CLICK VOICES	10
CONTROLLERS	Knobs and Ambient Slider Control

**DISPLAY CONNECTORS**

3.25" x 1" Graphic LCD	
Master Out L/Mono & R	
Direct Out (8)	
Headphones Out	
Aux In TRS Mini	
Main Trigger inputs (DB-25 Connector)	
Accessory Inputs (3)	
TO PC Port (USB-B)	
USB-A (for WAV files and Settings Data)	
MIDI Output	
MIDI	
POWER SUPPLY	100-120V, 50-60Hz, Switching Power Supply
DIMENSIONS, WEIGHT	2.2lbs, 9"W x 7.5"D x 2"H

# MIMIC PRO

POWERED BY SLATE

Download MIMIC PRO Software Updates and User Manual at [pearl-electronics-support.com](http://pearl-electronics-support.com)



MIMP24B

**THE MOST AMAZING DRUM MODULE THE WORLD HAS EVER KNOWN.**

SERIOUSLY, IT'S THAT GOOD.



Superior sound, accurate triggering and connectivity are the most important features of a drum module. Pearl Drums and Steven Slate have joined forces to create "Mimic Pro" - the world's most advanced percussion sound source for studio and live performance applications.

At the heart of this ground breaking unit is the new Steven Slate 5 drum library that features multi-channel drum samples recorded in world class studios. Each instrument supports adjustment of Attack, Sustain, Release, Tune, Pan and volume. Instead of substituting digital effects to create ambience, these instruments use the actual ambient recordings with separate adjustment of close, overhead and room mics.

Mimic Pro is the first drum module to implement a 7" IPS touch screen and the first to offer 2 mixers for independent headphone and front house outputs. Now that the drummer is responsible for triggering loops and other sounds for a performance, Mimic Pro can import audio files to trigger from your pads.

Storage is no longer a problem with Mimic's 120GB Solid State Drive and lightning fast loading time. Speaking of connectivity, Mimic Pro is compatible with Pearl TruTrac pads and a host of pads from other manufacturers. Top that off with sixteen audio outs, 16 Trigger inputs, independent SD card Slot, USB and Midi In & Out, Stereo Aux input and you would be hard pressed to find a better option for today's musician.

**mimic PRO**  
POWERED BY SLATE



## STATE OF THE ART FEATURES:

- 7" IPS Touch Screen with Programmable Data Wheel
- 120 gig Solid State drive
- 16 Dual Zone Inputs
- 16 Programmable Audio Outputs
- Midi In and Out
- High Quality Digital to Analog Converters
- Two completely separate mixers for headphone and Main outs. (Drummer gets a personal mix with and without effects independent of Main outputs)
- Import Wave, Aiff or MP3 sound files
- Compatible with most pads on the market
- Steven Slate Drums 5 Library
- 24 bit multi channel sample library with separate adjustment of Close, Overhead and Room mics.
- Onboard effects include EQ, Compression, Reverb with Room Sizes
- Individual Cymbal Volume Adjustments for Bell, Bow, Edge, Chik and Splash
- All AUX and Cymbal inputs have choke function.
- Supports triple and dual zone cymbals and dual zone hi hat.
- SD card slot and USB.
- Additional Instruments and Libraries will be available
- Stereo Aux In and Onboard Metronome
- Internal Recording for Loops and/or Performances

# malletSTATION™

**malletSTATION**  
THE WORLD'S FIRST 3.0 OCTAVE ADJUSTABLE RANGE ELECTRONIC MALLET CONTROLLER

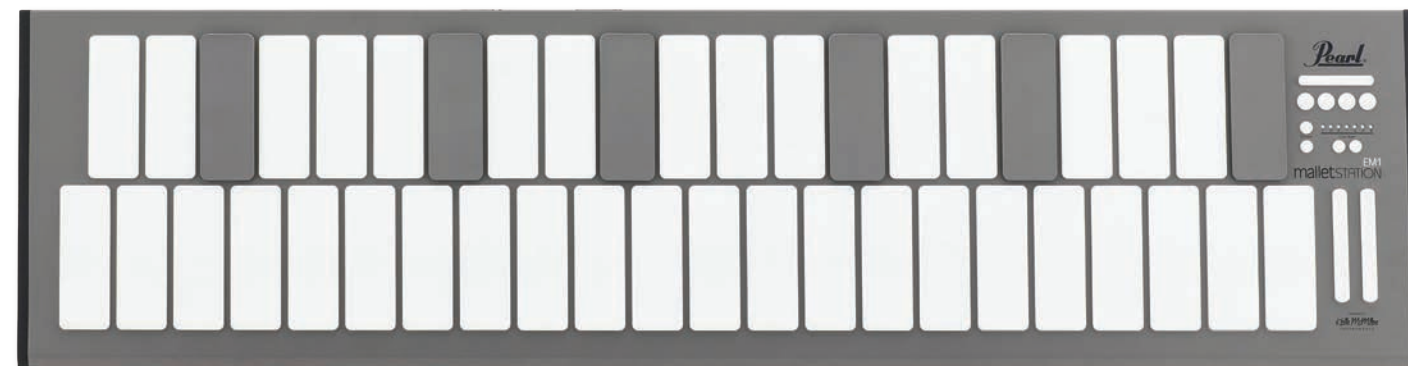

## PRACTICE, PERFORM, COMPOSE ANYWHERE.

EMI

- USB Powered MIDI Mallet Keyboard Controller
- Universal Compatibility through phone/tablet/laptop
- Tech-Forward Design featuring KMI Smart Fabric Sensors
- Low Note, Adjustable, User defined 3.0 Octave Range
- Customizable mallet dampening and aftertouch modes for realistic performance techniques
- Natural feeling soft silicone keys, all-weather playing surface
- Assignable buttons and faders for customized control and functions
- Three assignable pedal inputs for expression and sustain
- Hybrid Aluminum and Steel Chassis design for durability and stability
- Optional MIDI Expander to use external MIDI Hardware (sold separately)
- Flexible mounting on desktop, X-stand, or module mounts (sold separately)
- Mounting plates, stands, cases, covers, and other peripherals (available separately)



Shown Mounted on Vibraphone with Field Frame



Sleek, modern design with an ultra thin 1.6" profile

- 43, 1.75" x 5" soft silicone keys - 3 faders and 4 buttons, MIDI assignable - 3 MIDI assignable 1/4" pedal inputs
- Bottom Note Range Shift up/down buttons - Octave up/down buttons - 1.6" H x 12.6" W x 49" L - 22.5 lbs

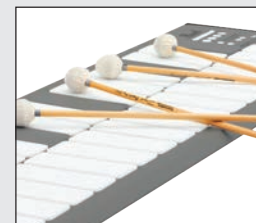

1.75" x 5" Soft Silicone Keys powered by KMI Smart Fabric Sensor Technology

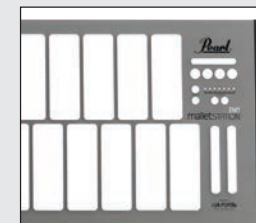

Software Assignable Control Panel with 3 Faders, 4 Buttons, plus Low Note and Octave Shift

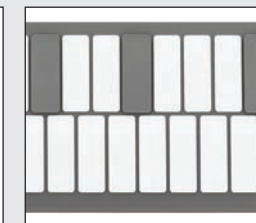

Moveable Accidental "Gap Caps" for visual cues when low note range is adjusted



Jack panel with USB MIDI, MIDI expander port, and 3 MIDI assignable 1/4" pedal inputs



Optional Dual Module Mounts allow malletSTATION to easily mount on racks, stands, and field frames

Pearl once again redefines the electronic percussion experience by introducing the revolutionary EMI malletSTATION adjustable range electronic mallet controller.

The EMI malletSTATION is a 3.0 octave adjustable range electronic mallet controller designed for all levels of player, from the beginning student through the gigging professional. The adjustable range function allows you to set the fundamental diatonic note of the instrument to what you need—low D xylophone? No problem! Powered exclusively by USB Bus Power, the malletSTATION is designed to be used with Mac, PC, iPad, iPhone, and Android devices, making it the first truly portable mallet percussion controller on the market.

Designed in collaboration with Keith McMillen Instruments, malletSTATION's tech-forward design features KMI's Smart Fabric

Sensor technology allowing the silicone bar material to have an extremely sensitive, natural response, including mallet dampening and aftertouch control, and all can be easily tailored to your individual playing style. The EMI features a master control section, with 3 programmable faders, 4 programmable buttons, and the fixed function low note and octave shift buttons. In addition, three assignable pedal inputs allow for flexibility in performance such as sustain, expression, or any MIDI parameter of your choice. These controls are fully programmable through a software editor so changing your configuration is as easy as clicking a mouse.

This is the controller that will grow with you throughout your playing career—from music apps on your phone or tablet, to professional digital audio workstations and sound libraries—your sounds and even the instruments you play are only limited by the software you run.

# PRESIDENT SERIES SNARES

PHENOLIC & DELUXE



President Series Phenolic

<b>PSP1455S/C</b>	14" x 5.5"
SHELL	4mm Phenolic
FINISH	#452 Pearl White Oyster
HOOPS	SuperHoop II (SH-1410B/1410S)
LUGS	BSL-55
TENSION RODS	T-062
MUFFLER	IM-100PHC
STRAINER	SR-17A / SR-150E
SNARES	SN-1420I



President Series Deluxe

<b>PSD1455SE/C</b>	14" x 5.5"
SHELL	6-ply 7.5mm Lauan
FINISH	#450 Silver Sparkle #767 Desert Ripple #768 Ocean Ripple
HOOPS	SuperHoop II (SH-1408B/1408S)
LUGS	BSL-55
TENSION RODS	T-062
MUFFLER	IM-100W
STRAINER	SR-17A / SR-150E
SNARES	SN-1420I



**PSD1455SE/C**  
#767 Desert Ripple



**PSD1455SE/C**  
#768 Ocean Ripple

SIGNED 75TH ANNIVERSARY EDITION. LIMITED QUANTITIES WORLDWIDE.

# REFERENCE SNARES

THE ULTIMATE STABLE OF SNARES



All Reference snare drums feature Pearl's SR-1000 Glide-Lock Strainer, which includes a locking throw off lever and tension knob that won't loosen no matter how hard you play. Low-friction technology permits smooth gliding action for ultra quiet, super precise motion. U.S. Patent #7220905, #7301087, #7365256



<b>RF1365S/C</b>	13" x 6.5"
SHELL	20 ply (25mm): Maple 14 + Birch 6
HOOPS	MasterCast (DC-1308/1308S)
LUGS	BRL-65
TENSION RODS	SST-5047 Stainless Steel
STRAINER	SR-1000 Glide-Lock Strainer
SNARES	SN-1320D Ultra Sound "D" type



**RF1365S/C**



**RFP1365S/C**

<b>RFP1365S/C</b>	13" x 6.5"
SHELL	6 ply (5.4 mm): Maple 4 + Birch 2
HOOPS	FatTone Hoops (FH-1308/1308S)
LUGS	STL-65
TENSION RODS	SST-5047 Stainless Steel
STRAINER	SR-1000 Glide-Lock Strainer
SNARES	SN-1320D Ultra-Sound "D" type

<b>RF1450S/C</b>	14" x 5"
SHELL	20 ply (25mm): Maple 14 + Birch 6
HOOPS	MasterCast (DC-1410/1410S)
LUGS	BRL-55
TENSION RODS	SST-5047 Stainless Steel
STRAINER	SR-1000 Glide-Lock Strainer
SNARES	SN-1420D Ultra Sound "D" type

<b>RFP1450S/C</b>	14" x 5"
SHELL	6 ply (5.4 mm): Maple 4 + Birch 2
HOOPS	FatTone Hoops (FH-1410/1410S)
LUGS	STL-55L
TENSION RODS	SST-5042 Stainless Steel
STRAINER	SR-1000 Glide-Lock Strainer
SNARES	SN-1420D Ultra-Sound "D" type

<b>RF1465S/B</b>	14" x 6.5"
SHELL	20 ply (25mm): Maple 14 + Birch 6
HOOPS	MasterCast (DC-1410/1410S)
LUGS	BRL-65
TENSION RODS	SST-5047 Stainless Steel
STRAINER	SR-1000 Glide-Lock Strainer
SNARES	SN-1420D Ultra Sound "D" type

<b>RFP1465S/C</b>	14" x 6.5"
SHELL	6 ply (5.4 mm): Maple 4 + Birch 2
HOOPS	FatTone Hoops (FH-1410/1410S)
LUGS	STL-65
TENSION RODS	SST-5047 Stainless Steel
STRAINER	SR-1000 Glide-Lock Strainer
SNARES	SN-1420D Ultra-Sound "D" type

<b>RFB1450</b>	14" x 5"
SHELL	3mm Brass
HOOPS	MasterCast (DC-1410/1410S)
LUGS	BRL-55
TENSION RODS	SST-5047 Stainless Steel
STRAINER	SR-1000 Glide-Lock Strainer
SNARES	SN-1420D Ultra-Sound "D" type

<b>RFB1465</b>	14" x 6.5"
SHELL	3mm Brass
HOOPS	MasterCast (DC-1410/1410S)
LUGS	BRL-65
TENSION RODS	SST-5042 Stainless Steel
STRAINER	SR-1000 Glide-Lock Strainer
SNARES	SN-1420D Ultra-Sound "D" type

<b>RFS1450</b>	14" x 5"
SHELL	2.5mm Cast Steel / 2.5mm R-Ring
HOOPS	MasterCast (DC-1410/1410S)
LUGS	BRL-55
TENSION RODS	SST-5047 Stainless Steel
STRAINER	SR-1000 Glide-Lock Strainer
SNARES	SN-1420D Ultra-Sound "D" type

<b>RFS1465</b>	14" x 6.5"
SHELL	2.5mm Cast Steel / 2.5mm R-Ring
HOOPS	MasterCast (DC-1410/1410S)
LUGS	BRL-65
TENSION RODS	SST-5047 Stainless Steel
STRAINER	SR-1000 Glide-Lock Strainer
SNARES	SN-1420D Ultra-Sound "D" type



**RF1450S/C**



**RFP1450S/C**



**RFB1450**



**RFB1465**



**RF1465S/B**



**RFP1465S/C**



**RFS1450**



**RFS1465**

# SERIES COMPONENT

MASTERS, SESSION, DECADE  
CLASSIC PEARL SOUND

## DRUM SET SERIES SNARE DRUMS

Made to match the sound and feel of your Pearl drum set.



### TASK-SPECIFIC INNOVATION

Pearl's unique Free Floating Snare chassis removes all hardware from the shell to greatly improve resonance and projection.

By combining the tonal character of each shell type with its ideally matched depth, each Free Floating snare drum is engineered to fit a specific task by model and gives you a unique voice for any sonic situation.

# FREE FLOATING

THE ULTIMATE PURITY OF SOUND

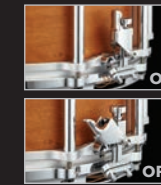

**CLICK-LOCK THROW-OFF SYSTEM** Engineered with Polymer bearings for precise and smooth action. Unique nylon grip mechanism locks the snares into place.



MRV1455S/C



MRV1465S/C

### MRV1455S/C 14" x 5.5"

SHELL	4 Ply Maple with 4 ply Maple R-Rings
HOOPS	FatTone (FH-1410/1410S)
LUGS	STL-55
TENSION RODS	SST-5055 Stainless Steel
STRAINER	SR-017
SNARES	S-022N

### MRV1465S/C 14" x 6.5"

SHELL	4 Ply Maple with 4 ply Maple R-Rings
HOOPS	FatTone (FH-1410/1410S)
LUGS	STL-65
TENSION RODS	SST-5047 Stainless Steel
STRAINER	SR-017
SNARES	S-022N



Deep, rich snare power with short, even sustain decay.  
**FTAL1480**



Ultimate in throaty, deep snare growl. Shortened decay.  
**FTMH1480**

### FTAL1480 14" x 8"

SHELL	1.2mm Seamless Aluminum
HOOPS	MasterCast (DC-1410/DC-1410S)
LUGS	FT-80
TENSION RODS	SST-5042
STRAINER	SR-160F
SNARES	SN-1442C

### FTMH1480 14" x 8"

SHELL	8 ply (10mm) African Mahogany
HOOPS	MasterCast (DC-1410/DC-1410S)
LUGS	FT-80
TENSION RODS	SST-5042
STRAINER	SR-160F
SNARES	SN-1442C



MCT1455S/C



MCT1465S/C

### MCT1455S/C 14" x 5.5"

SHELL	6 Ply Maple (5.4mm)
HOOPS	SuperHoop II (SH-1410B/1410S)
LUGS	CL-55
TENSION RODS	T-062
STRAINER	SR-017
SNARES	S-022N

### MCT1465S/C 14" x 6.5"

SHELL	6 Ply Maple (5.4mm)
HOOPS	SuperHoop II (SH-1410B/1410S)
LUGS	CL-65
TENSION RODS	T-061L
STRAINER	SR-017
SNARES	S-022N



Lower overtone body, preserves crisp top-end snare snap.  
**FTPBI465**



Full, rounded bottom frequencies. Extra midrange body.  
**FTMMH1465**

### FTPBI465 14" x 6.5"

SHELL	1.2mm Phosphor Bronze
HOOPS	MasterCast (DC-1410/DC-1410S)
LUGS	FT-65
TENSION RODS	SST-5042
STRAINER	SR-160F
SNARES	SN-1420C

### FTMMH1465 14" x 6.5"

SHELL	6 ply (7.5mm) 4 ply Maple w/ 2 ply inner African Mahogany
HOOPS	MasterCast (DC-1410/DC-1410S)
LUGS	FT-65
TENSION RODS	SST-5042
STRAINER	SR-160F
SNARES	SN-1420C



STS1480S/C



STS1465S/C

### STS1480S/C 14" x 8"

SHELL	6-ply (5.4mm) Birch/African Mahogany
HOOPS	SuperHoop II (SH-1410B/1410S)
LUGS	CL-100
TENSION RODS	T-061L
STRAINER	SR-017
SNARES	S-022N

### STS1465S/C 14" x 6.5"

SHELL	6-ply (5.4mm) Birch/African Mahogany
HOOPS	SuperHoop II (SH-1410B/1410S)
LUGS	CL-65
TENSION RODS	T-061L
STRAINER	SR-017
SNARES	S-022N



Full-spectrum, both bright in punch and warm in tone.  
**FTBRI450**



Punchy and smooth. A perfect "go-to" snare.  
**FTMMI450**

### FTBRI450 14" x 5"

SHELL	1mm Brass
HOOPS	MasterCast (DC-1410/DC-1410S)
LUGS	FT-50
TENSION RODS	SST-5042
STRAINER	SR-160F
SNARES	SN-1420I

### FTMMI450 14" x 5"

SHELL	6 ply (7.5mm) Maple
HOOPS	MasterCast (DC-1410/DC-1410S)
LUGS	FT-50
TENSION RODS	SST-5042
STRAINER	SR-160F
SNARES	SN-1420I



STS1455S/C



DMP1455S/C

### STS1455S/C 14" x 5.5"

SHELL	6-ply (5.4mm) Birch/African Mahogany
HOOPS	SuperHoop II (SH-1410B/1410S)
LUGS	CL-55
TENSION RODS	T-062
STRAINER	SR-017
SNARES	S-022N

### DMP1455S 14" x 5.5"

SHELL	6 Ply Maple (5.4mm)
HOOPS	1.6mm Steel (RH-1408/1408S)
LUGS	NDL-55/C
TENSION RODS	TR-5052
STRAINER	SR-700
SNARES	SNW-1420



1mm shell for bright, open attack with ringy overtone.  
**FTSSI435**



Dense all Birch shell delivers bright, open attack.  
**FTBBI435**

### FTSSI435 14" x 3.5"

SHELL	1mm Stainless Steel
HOOPS	MasterCast (DC-1410/DC-1410S)
LUGS	FT-35
TENSION RODS	SST-5035
STRAINER	SR-160F
SNARES	SN-1420D

### FTBBI435 14" x 3.5"

SHELL	6 ply (5.4mm) Birch
HOOPS	MasterCast (DC-1410/DC-1410S)
LUGS	FT-35
TENSION RODS	SST-5035
STRAINER	SR-160F
SNARES	SN-1420D

# SENSITONE HERITAGE ALLOY

LEGENDARY, VITAL SNARE TONE FROM STUDIO TO STAGE

The Sensitone sound has always been drawn from an amalgamation of The Heritage Alloys (Aluminum, Black-over-Brass, and Steel) for the necessary, immediate tones of yesterday's chart toppers with an undeniably modern sensibility. Sensitone Heritage Alloy snare models employ these three original metal shell types to deliver essential tone and power with the right gig-ready touches.

Engineered for performance perfection, Sensi Tone Premium snare drums feature a choice of 14" models, available in 5" and 6.5" depths, in Patina Beaded Brass, Beaded Phosphor Bronze, or even North American Maple shells. Additionally, the African Mahogany 15" x 5" Baritone snare brings a deep, fresh voice to the tonal pallet.

# SENSITONE PREMIUM

IMMACULATE PERCUSSION



Dry, focused crack with quick decay.  
**STH1450AL**



Full, guttural snare bellow with little overtone.  
**STH1465AL**

<b>STH1450AL</b>	14" x 5"
SHELL	1.2mm Seamless Aluminum
HOOPS	SuperHoop II (SH-1410B/1410S)
LUGS	CL-55
TENSION RODS	T-061L
STRAINER	SR-017
SNARES	SN-1420I

<b>STH1465AL</b>	14" x 6.5"
SHELL	1.2mm Seamless Aluminum
HOOPS	SuperHoop II (SH-1410B/1410S)
LUGS	CL-65
TENSION RODS	T-061L
STRAINER	SR-017
SNARES	SN-1420I



Bright and responsive with lively overtone.  
**STA1450FB**



Bold projection with controlled ring sustain.  
**STA1465FB**

<b>STA1450FB</b>	14" x 5"
SHELL	1.5mm Beaded Brass
HOOPS	SuperHoop II (SH-1410B/1410S)
LUGS	ARL-55
TENSION RODS	SST-5047
STRAINER	SR-150
SNARES	SN-1420I

<b>STA1465FB</b>	14" x 6.5"
SHELL	1.5mm Beaded Brass
HOOPS	SuperHoop II (SH-1410B/1410S)
LUGS	ARL-65
TENSION RODS	SST-5047
STRAINER	SR-150
SNARES	SN-1420I



Perfect blend of attack and brassy body.  
**STH1450BR**



An elegant solution for punch and warmth.  
**STH1465BR**

<b>STH1450BR</b>	14" x 5"
SHELL	1mm Beaded Brass
HOOPS	SuperHoop II (SH-1410B/1410S)
LUGS	CL-55
TENSION RODS	T-061L
STRAINER	SR-017
SNARES	SN-1420I

<b>STH1465BR</b>	14" x 6.5"
SHELL	1mm Beaded Brass
HOOPS	SuperHoop II (SH-1410B/1410S)
LUGS	CL-65
TENSION RODS	T-061L
STRAINER	SR-017
SNARES	SN-1420I



Musical and penetrating with mid-range power.  
**STA1450PB**



Bellowing low-end wallop with smooth articulation.  
**STA1465PB**

<b>STA1450PB</b>	14" x 5"
SHELL	1.2mm Phosphor Bronze
HOOPS	SuperHoop II (SH-1410B/1410S)
LUGS	ARL-55
TENSION RODS	SST-5047
STRAINER	SR-150
SNARES	SN-1420I

<b>STA1465PB</b>	14" x 6.5"
SHELL	1.2mm Phosphor Bronze
HOOPS	SuperHoop II (SH-1410B/1410S)
LUGS	ARL-65
TENSION RODS	SST-5047
STRAINER	SR-150
SNARES	SN-1420I



Crisp, sensitive high-pitched snap.  
**STH1450S**



Belting crack with mild midrange overtone.  
**STH1465S**

<b>STH1450S</b>	14" x 5"
SHELL	1mm Beaded Steel
HOOPS	SuperHoop II (SH-1410B/1410S)
LUGS	CL-55
TENSION RODS	T-061L
STRAINER	SR-017
SNARES	SN-1420I

<b>STH1465S</b>	14" x 6.5"
SHELL	1mm Beaded Steel
HOOPS	SuperHoop II (SH-1410B/1410S)
LUGS	CL-65
TENSION RODS	T-061L
STRAINER	SR-017
SNARES	SN-1420I



Top-end projection with fat highs and mids.  
**STA1450MM**



Thick snare tone with suppressed mid-tonality.  
**STA1465MM**

<b>STA1450MM</b>	14" x 5"
SHELL	6 ply 5.4mm Maple
HOOPS	SuperHoop II (SH-1410B/1410S)
LUGS	ARL-55
TENSION RODS	SST-5047
STRAINER	SR-150
SNARES	SN-1420D

<b>STA1465MM</b>	14" x 6.5"
SHELL	6 ply 5.4mm Maple
HOOPS	SuperHoop II (SH-1410B/1410S)
LUGS	ARL-65
TENSION RODS	SST-5047
STRAINER	SR-150
SNARES	SN-1420D

## THE SR-017 STRAINER

Simple and effective, the SR-017 is a Pearl standard for effortless snare switching and sensitivity control. Its smooth lever action and fine-tuning knob let you dial in the right amount of snare wire saturation to suit your personal sound.



ON

OFF



ARL-65

ARL-55

The stylish Arch-Tube Lug features a low contact design with separate self-aligning swivel nuts for pristine tuning across the head and reduced binding within the lug. (U.S. Patent #9502013)



The Baritone Snare, low end tone with top end snap.  
**STA1550MH**

<b>STA1550MH</b>	15" x 5"
SHELL	4 Ply 5mm African Mahogany w/ Maple Reinforcement Rings
HOOPS	SuperHoop II (SH-1510B/1510S)
LUGS	ARL-55
TENSION RODS	SST-5047
STRAINER	SR-150
SNARES	SN-1520I

Sensi Tone Premium's selection of refined percussion instruments are sure to be first call drums for the stage, studio, and beyond.

# SIGNATURE

CAPTURING THE EXCLUSIVE SOUND OF DRUMMING LEGENDS

## MATT HALPERN



<b>MH1460B</b>	14" x 6"
<b>SHELL</b>	1.5mm Black Powder-Coated Brass
<b>HOOPS</b>	MasterCast (DCB-1410/1410S)
<b>LUGS</b>	STL-55MH/B
<b>TENSION RODS</b>	SST-5052
<b>STRAINER</b>	SR-150B
<b>SNARES</b>	SN-1420I
<b>FINISHES</b>	Custom Black



VENTS AH03 (x3)

## IAN PAICE



<b>IP1465</b>	14" x 6.5"
<b>SHELL</b>	Beaded Steel Shell
<b>HOOPS</b>	SuperHoop II (SH-1410B/1410S)
<b>LUGS</b>	TB-65 w/ TL-20
<b>TENSION RODS</b>	SST-5042 Stainless Steel (10)
<b>STRAINER</b>	SR-017
<b>SNARES</b>	S-022N
<b>FINISHES</b>	Chrome-Plated



## BRIAN FRASIER-MOORE



<b>BFM1455S/C</b>	14" x 5.5"
<b>SHELL</b>	12-Ply, 15mm Gum/Maple/Gum
<b>HOOPS</b>	MasterCast (DC-1410/1410S)
<b>LUGS</b>	CL-55
<b>TENSION RODS</b>	T-062
<b>STRAINER</b>	SR-150
<b>SNARES</b>	SN-1442I
<b>FINISHES</b>	Gloss Gumwood Naturalburst



## JOEY JORDISON



<b>JJ1365N</b>	13" x 6.5"
<b>SHELL</b>	Steel/Black Shell
<b>HOOPS</b>	SuperHoop II (SHB1308/1308S)
<b>LUGS</b>	CL-65B
<b>TENSION RODS</b>	SST-5047 Stainless Steel (10)
<b>STRAINER</b>	SR-017/B
<b>SNARES</b>	S-029N
<b>FINISHES</b>	Custom Black



## DENNIS CHAMBERS



<b>DC1450S/N</b>	14" x 5"
<b>SHELL</b>	Cast Aluminum: 3mm w/ 2mm R. Rings
<b>HOOPS</b>	SuperHoop II (SHN-1412B/1408S)
<b>LUGS</b>	STL-100 (12 over 8)
<b>TENSION RODS</b>	SST-5047 Stainless Steel (20)
<b>STRAINER</b>	SR-020N Multi-Trace Strainer System
<b>SNARES</b>	SN-1420I
<b>FINISHES</b>	Black Nickel Shell w/ Nickel Hardware



## OMAR HAKIM



<b>OH1350</b>	13" x 5"
<b>SHELL</b>	6 ply African Mahogany Shell
<b>HOOPS</b>	2.3mm SuperHoop II (SH1308/1308S)
<b>LUGS</b>	CL-55
<b>TENSION RODS</b>	SST-5047 Stainless Steel (8)
<b>STRAINER</b>	SR-015 Gladstone Style
<b>SNARES</b>	S-029N
<b>FINISHES</b>	#140 Natural Mahogany





# HYBRID EXOTIC

SPACE-AGE PRECISION, TIMELESS TONE

For the ultimate in power and prestige. Shell choices include spun-composite, seamless Cast Aluminum, and Kapur/Fiberglass.

**GLIDE-LOCK THROW-OFF SYSTEM** Pearl's SR-1000 Glide-Lock Strainer's locking throw-off lever and tension knob assures worry free, slip-free performance from all Hybrid Exotic Snare Drums. (U.S. Patent #7220905, #7301087, #7365256.)



# DUOLUXE

THE WORLD'S FIRST INLAID BRASS SNARE DRUM

Pearl celebrates three-quarters of a century of iconic drum sounds with Duoluxe, a modern take our legendary Jupiter snare drum. This classic combination of a chrome-over-brass alloy shell and our trademark dual inverted shell beads is augmented with two finish bands of Nicotine White Marine Pearl inlay. This gives the shell a singular look and adds tonal nuance to its unbridled sound.



Articulate snare punch, best at higher tunings.  
**HEK1450**



Lively blend of throaty snare holler and punchy projection.  
**HEK1465**

<b>HEK1450</b>	14" x 5"
<b>SHELL</b>	6 ply 7.5mm Kapur w/ Inner Fiberglass
<b>HOOPS</b>	SuperHoop II (SH-1410B/1410S)
<b>LUGS</b>	STL-100
<b>TENSION RODS</b>	SPT-5047 (top) - SST-5047 (bottom)
<b>STRAINER</b>	SR-1000
<b>SNARES</b>	SN-1420D
<b>HEK1465</b>	14" x 6.5"
<b>SHELL</b>	6 ply 7.5mm Kapur w/ Inner Fiberglass
<b>HOOPS</b>	SuperHoop II (SH-1410B/1410S)
<b>LUGS</b>	STL-100
<b>TENSION RODS</b>	SPT-5047 (top) - SST-5047 (bottom)
<b>STRAINER</b>	SR-1000
<b>SNARES</b>	SN-1420D



Bold and crisp with short midrange overtone.  
**DUX1450BR**



Fierce and centered mid-to-low sustain.  
**DUX1465BR**

<b>DUX1450BR</b>	14" x 5"
<b>SHELL</b>	1mm Dual-Beaded Chrome-Brass
<b>HOOPS</b>	SuperHoop II (SH-1410B/1410S)
<b>INLAY</b>	#405 Nicotine White Marine Pearl (x2)
<b>LUGS</b>	BSL-55
<b>TENSION RODS</b>	SST-5042
<b>STRAINER</b>	SR-017A/SR-150E
<b>SNARES</b>	SN-1420I
<b>DUX1465BR</b>	14" x 6.5"
<b>SHELL</b>	1mm Dual-Beaded Chrome-Brass
<b>HOOPS</b>	SuperHoop II (SH-1410B/1410S)
<b>INLAY</b>	#405 Nicotine White Marine Pearl (x2)
<b>LUGS</b>	BSL-55
<b>TENSION RODS</b>	SST-5055
<b>STRAINER</b>	SR-017A/SR-150E
<b>SNARES</b>	SN-1420I

**SPIN-TIGHT™ TENSION RODS** To maintain tuning tension across the batter head, all Hybrid Exotic snare drums feature Pearl's Spin-Tight tension rods. This elegantly simple innovation creates a tension rod-within-a-tension rod, that allows the rod to expand and lock into place within the swivel nut. Utilizing a special drum key, tunings can be controlled under high-impact play like never before.



<b>HEK1480</b>	14" x 8"
<b>SHELL</b>	6 ply 7.5mm Kapur w/ Inner Fiberglass
<b>HOOPS</b>	SuperHoop II (SH-1410B/1410S)
<b>LUGS</b>	STL-100
<b>TENSION RODS</b>	SPT-5047 (top) - SST-5047 (bottom)
<b>STRAINER</b>	SR-1000
<b>SNARES</b>	SN-1442D
Low, thunderous wallop with deep, solid playability. <b>HEK1480</b>	



# STAVECRAFT

FEATURING THE EXCLUSIVE DADO-LOC JOINT

A startling addition to any pro drummer's soundscape, each StaveCraft shell starts from two layers of meticulously beveled solid Makha or ThaiOak staves. Dado-Loc, an old world principal exclusive to these snares, inserts a segment

of corresponding wood into the center Dado channel formed by each stave and increases total shell strength by 50%. This solid fusion of hardwoods is lathed to a perfectly round 25mm thickness for unparalleled volume and power.



Dry, high-pitched crack with little overtone.  
**HEAL1450**



Fat midrange focus without sacrificing volume.  
**HEAL1465**

<b>HEAL1450</b>	14" x 5"
<b>SHELL</b>	Cast Aluminum: 3mm w/ 2mm R-Rings
<b>HOOPS</b>	SuperHoop II (SH-1410B/1410S)
<b>LUGS</b>	STL-100
<b>TENSION RODS</b>	SPT-5047 (top) - SST-5047 (bottom)
<b>STRAINER</b>	SR-1000
<b>SNARES</b>	SN-1420I
<b>HEAL1465</b>	14" x 6.5"
<b>SHELL</b>	Cast Aluminum: 3mm w/ 2mm R-Rings
<b>HOOPS</b>	SuperHoop II (SH-1410B/1410S)
<b>LUGS</b>	STL-100
<b>TENSION RODS</b>	SPT-5047 (top) - SST-5047 (bottom)
<b>STRAINER</b>	SR-1000
<b>SNARES</b>	SN-1420I



Quick, tight high-range tonal power.  
**SCD1450TO**



Sensitive, centered low-overtone drive.  
**SCD1465TO**

<b>SCD1450TO</b>	14" x 5"
<b>SHELL</b>	25mm Dual Thai Oak Stave w/ Makha DadoLoc
<b>HOOPS</b>	MasterCast (DC-1410/1410S)
<b>LUGS</b>	STL-55L
<b>TENSION RODS</b>	SST-5042
<b>STRAINER</b>	SR-150
<b>SNARES</b>	SN-1420I
<b>SCD1465TO</b>	14" x 6.5"
<b>SHELL</b>	25mm Dual Thai Oak Stave w/ Makha DadoLoc
<b>HOOPS</b>	MasterCast (DC-1410/1410S)
<b>LUGS</b>	STL-65
<b>TENSION RODS</b>	SST-5047
<b>STRAINER</b>	SR-150
<b>SNARES</b>	SN-1420I



Quick, yielding snap with heavy midrange overtones.  
**HEP1450**

<b>HEP1450</b>	14" x 5"
<b>SHELL</b>	VectorCast
<b>HOOPS</b>	SuperHoop II (SH-1410B/1410S)
<b>LUGS</b>	STL-100
<b>TENSION RODS</b>	SPT-5047 (top) - SST-5047 (bottom)
<b>STRAINER</b>	SR-1000
<b>SNARES</b>	SN-1420C



Cracking tonal pop with short midrange hum.  
**SCD1450MK**



Thick, cavernous sonic body with cutting punch.  
**SCD1465MK**

<b>SCD1450MK</b>	14" x 5"
<b>SHELL</b>	25mm Dual Makha Stave w/ Thai Oak DadoLoc
<b>HOOPS</b>	MasterCast (DC-1410/1410S)
<b>LUGS</b>	STL-55L
<b>TENSION RODS</b>	SST-5042
<b>STRAINER</b>	SR-150
<b>SNARES</b>	SN-1420I
<b>SCD1465MK</b>	14" x 6.5"
<b>SHELL</b>	25mm Dual Makha Stave w/ Thai Oak DadoLoc
<b>HOOPS</b>	MasterCast (DC-1410/1410S)
<b>LUGS</b>	STL-65
<b>TENSION RODS</b>	SST-5047
<b>STRAINER</b>	SR-150
<b>SNARES</b>	SN-1420I

# UTILITY

VERSATILE DRUMS FOR SECONDARY EFFECTS

**MODERN UTILITY** snare drums are vital instruments. Well-appointed tools of the trade crafted for the informed, current drummer to make the gig great. Priced for the active working player, Modern Utility snares are available in both 100% Maple and Beaded Steel. Flexible enough to add to any setup and strong enough to stand up to constant play, each model has a cool, versatile vibe. Featuring our CL arch lugs and smooth SR-700 snare strainer for precise tunability.



See Korn drummer Ray Luzier's performance test of each Modern Utility snare at [pearldrums.com](http://pearldrums.com)



MUS1480M



MUS1410FM

Leg Brackets: FTB-07/C (x3)



MUS1455M



MUS1465M



MUS1350M



MUS1270M

## MODERN UTILITY

<b>MUS1480M</b>	14" x 8"
<b>SHELL</b>	6 Ply Maple (5.4mm)
<b>HOOPS</b>	1.6mm Steel (SH-1006/1006S)
<b>LUGS</b>	CL-100
<b>TENSION RODS</b>	TR-5047 (12)
<b>STRAINER</b>	SR-700
<b>SNARES</b>	S-032N
<b>FINISHES</b>	#224 Matte Natural, #227 Satin Black

<b>MUS1410FM</b>	14" x 10"
<b>SHELL</b>	6 ply Maple (5.4mm)
<b>HOOPS</b>	1.6mm Steel (RH-1408/1408S)
<b>LUGS</b>	CL-100
<b>TENSION RODS</b>	TR-5047 (16)
<b>STRAINER</b>	SR-017
<b>SNARES</b>	SNW-1420
<b>FINISHES</b>	Satin Brown (#220)

<b>MUS1455M</b>	14" x 5.5"
<b>SHELL</b>	6 ply Maple (5.4mm)
<b>HOOPS</b>	1.6mm Steel (RH-1408/1408S)
<b>LUGS</b>	CL-55
<b>TENSION RODS</b>	TR-5052 (16)
<b>STRAINER</b>	SR-700
<b>SNARES</b>	SNW-1420
<b>FINISHES</b>	#224 Matte Natural, #227 Satin Black

<b>MUS1465M</b>	14" x 6.5"
<b>SHELL</b>	6 ply Maple (5.4mm)
<b>HOOPS</b>	1.6mm Steel (RH-1408/1408S)
<b>LUGS</b>	CL-65
<b>TENSION RODS</b>	TR-5047 (16)
<b>STRAINER</b>	SR-700
<b>SNARES</b>	SNW-1420
<b>FINISHES</b>	#224 Matte Natural, #227 Satin Black

<b>MUS1350M</b>	13" x 5"
<b>SHELL</b>	6 ply Maple (5.4mm)
<b>HOOPS</b>	1.6mm Steel (RH-1308/1308S)
<b>LUGS</b>	CL-55
<b>TENSION RODS</b>	TR-5047 (16)
<b>STRAINER</b>	SR-700
<b>SNARES</b>	SNW-1316
<b>FINISHES</b>	#224 Matte Natural, #227 Satin Black

<b>MUS1270M</b>	12" x 7"
<b>SHELL</b>	6 ply Maple (5.4mm)
<b>HOOPS</b>	1.6mm Steel (RH-1206/1206S)
<b>LUGS</b>	CL-65
<b>TENSION RODS</b>	TR-5057 (12)
<b>STRAINER</b>	SR-700
<b>SNARES</b>	SNW-1216
<b>FINISHES</b>	#224 Matte Natural, #227 Satin Black

### EFFECTS SNARES



<b>M1060</b>	10" x 6"
<b>SHELL</b>	6 Ply Maple (7.5mm)
<b>HOOPS</b>	SuperHoop II (SH-1006/1006S)
<b>LUGS</b>	CL-65
<b>TENSION RODS</b>	SST-5035 (12)
<b>STRAINER</b>	SR-018
<b>SNARES</b>	S-032N



<b>M1270</b>	12" x 7"
<b>SHELL</b>	8 Ply Maple (10mm)
<b>HOOPS</b>	1.6mm Steel (RIM-1206/1206S)
<b>LUGS</b>	CL-100
<b>TENSION RODS</b>	SST-5047 Stainless Steel (16)
<b>STRAINER</b>	SR-018
<b>SNARES</b>	S-031N



Bracket & Mount Included

<b>SFS10/C31</b>	10" x 4.5"
<b>SHELL</b>	6 Ply Poplar
<b>HOOPS</b>	1.6mm Steel (RIM-1006RSH/1006RSH)
<b>LUGS</b>	MSFL-35
<b>TENSION RODS</b>	RSHT-3240 (12)
<b>STRAINER</b>	SR-02MSFL/SR-02EMSFL
<b>SNARES</b>	SN-10MSFL

### PICCOLO



<b>B1330</b>	13" x 3"
<b>SHELL</b>	1.0mm Brass
<b>HOOPS</b>	1.6mm Steel (RIM-1308/1308S)
<b>LUGS</b>	CL-05
<b>TENSION RODS</b>	T-055 (16)
<b>STRAINER</b>	SR-018
<b>SNARES</b>	S-029N



<b>S1330B</b>	13" x 3"
<b>SHELL</b>	1.0mm Black-finish Steel
<b>HOOPS</b>	1.6mm Steel (RIM-1308/1308S)
<b>LUGS</b>	CL-05
<b>TENSION RODS</b>	T-055 (16)
<b>STRAINER</b>	SR-018
<b>SNARES</b>	S-029N



<b>M1330</b>	13" x 3"
<b>SHELL</b>	6ply Maple (7.5mm)
<b>HOOPS</b>	1.6mm Steel (RIM-1308/1308S)
<b>LUGS</b>	CL-05
<b>TENSION RODS</b>	T-055 (16)
<b>STRAINER</b>	SR-018
<b>SNARES</b>	S-029N

### FIRECRACKER



<b>FCP1250</b>	12" x 5"
<b>SHELL</b>	8 ply Poplar (10mm)
<b>HOOPS</b>	1.6mm Steel (RIM-1206/1206S)
<b>LUGS</b>	CL-50
<b>TENSION RODS</b>	T-062 (12)
<b>STRAINER</b>	SR-018
<b>SNARES</b>	S-031



<b>FCS1050</b>	10" x 5"
<b>SHELL</b>	1.0mm Steel
<b>HOOPS</b>	1.6mm Steel (RH-1006/1006SL)
<b>LUGS</b>	CL-50
<b>TENSION RODS</b>	T-062 (12)
<b>STRAINER</b>	SR-018
<b>SNARES</b>	S-032

**THE IGNITER** To capture the searing energy of drumming for a new generation of players, Pearl collaborated with viral video drummer Casey Cooper to create The Igniter. Specifically created to instantly improve the sound of any student drum kit, it's a fantastic value to keep the fire of drumming burning bright!

# EFFECTS

<b>CC1450S/C</b>	14" x 5"
<b>SHELL</b>	6-ply 6.8mm Poplar/Maple
<b>HOOPS</b>	1.6mm Steel (RH-1408/1408S)
<b>LUGS</b>	CL-55
<b>TENSION RODS</b>	TR-5047 (16)
<b>STRAINER</b>	SR-700
<b>SNARES</b>	SNW-1420
<b>FINISHES</b>	Artisan II Flame Wrap

COLLABORATION CASEY COOPER @COOP3RDRUMM3R



# DEMON PEDALS

THE FASTEST, SMOOTHEST, MOST POWERFUL PEDALS IN THE WORLD

DRIVE	Direct Drive
FOOT BOARD	Duo-Deck Convertible
LINK ADJUSTMENT	Dual Position
BEATER	Control Core
TENSION ADJUSTMENT	Click-Lock
DRIVE BEARINGS	NiNJa Low-Friction
PEDAL HEIGHT	Infinitely Adjustable
BEATER ANGLE	Infinitely Adjustable
CASE	Included



U.S. Patent #7579540

A choice of 2 positions for a finesse or power feel. Simply loosen the clamshell to change position.

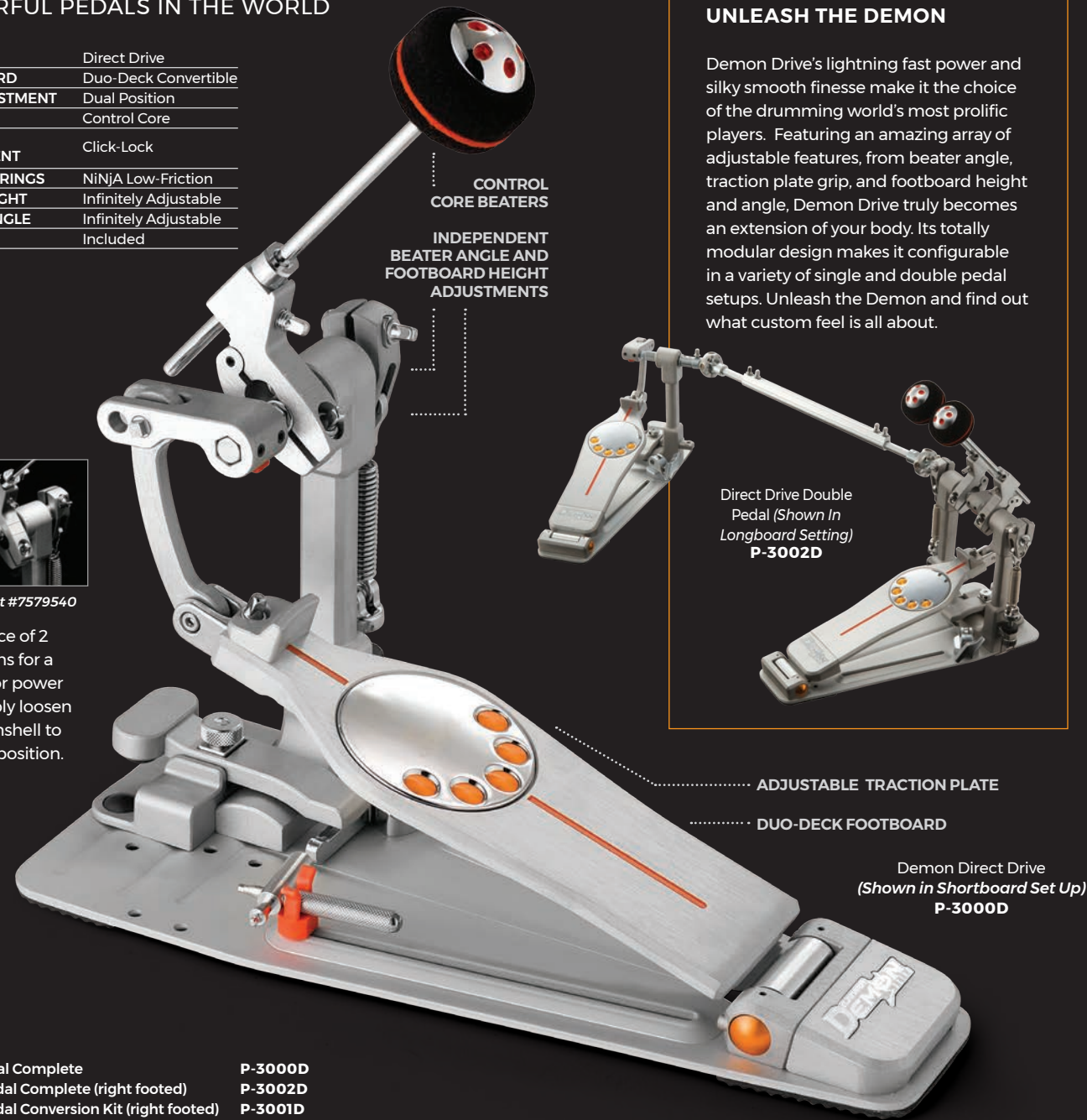

Single Pedal Complete	<b>P-3000D</b>
Double Pedal Complete (right footed)	<b>P-3002D</b>
Double Pedal Conversion Kit (right footed)	<b>P-3001D</b>
Double Pedal Complete (left footed)	<b>P-3002DL</b>

# DEMON DRIVE

## UNLEASH THE DEMON

Demon Drive's lightning fast power and silky smooth finesse make it the choice of the drumming world's most prolific players. Featuring an amazing array of adjustable features, from beater angle, traction plate grip, and footboard height and angle, Demon Drive truly becomes an extension of your body. Its totally modular design makes it configurable in a variety of single and double pedal setups. Unleash the Demon and find out what custom feel is all about.



Direct Drive Double Pedal (Shown In Longboard Setting) **P-3002D**

Demon Direct Drive (Shown in Shortboard Set Up) **P-3000D**



# DEMON CHAIN

## TRADITIONAL FEEL AND POWER OF A CHAIN

An innovative combination of Demon Drive speed and traditional chain drive feel, the Demon Chain's Perfect Circle cam delivers smooth, consistent response throughout the stroke for pinpoint accuracy and control. A high performance package for the driven power drummer.

Single Pedal Complete	<b>P-3000C</b>
Double Pedal Complete (right footed)	<b>P-3002C</b>
Double Pedal Conversion Kit (right footed)	<b>P-3001C</b>
Double Pedal Complete (left footed)	<b>P-3002CL</b>

## EQUIPMENT FAILURE IS NOT AN OPTION, END OF STORY.

Pearl's hardware is LEGENDARY. So rugged, sure-footed, and built to last that we back it up with PEARL'S EXCLUSIVE Lifetime Warranty.

DRIVE	Ultralight Chain
FOOT BOARD	Duo-Deck Convertible
DRIVE CAM	Perfect Circle "Linear Response" Cam
BEATER	Control Core
TENSION ADJUSTMENT	Click-Lock
DRIVE BEARINGS	NiNJa Low-Friction
PEDAL HEIGHT	Infinitely Adjustable
BEATER ANGLE	Infinitely Adjustable
CASE	Included

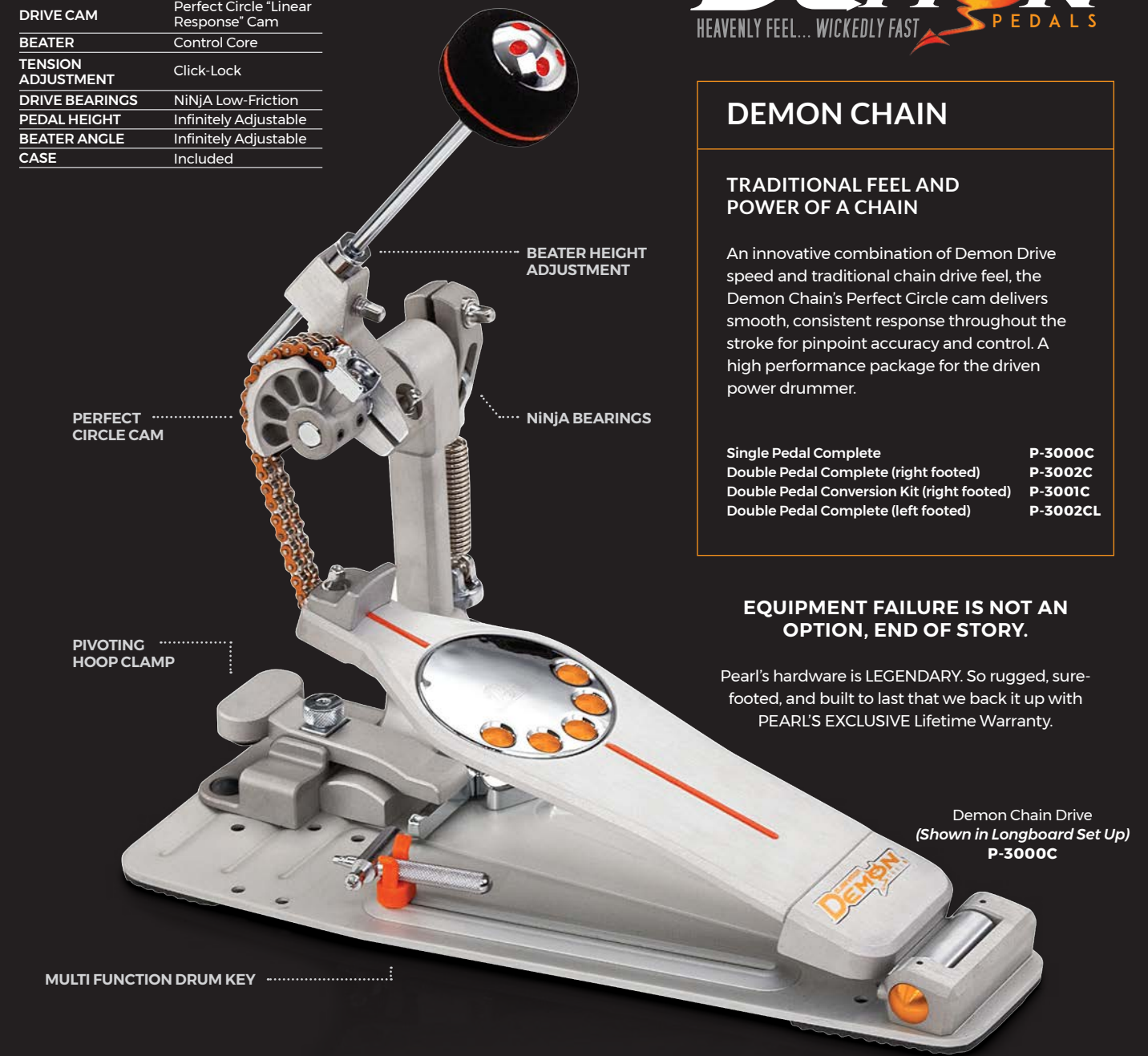

MULTI FUNCTION DRUM KEY

Demon Chain Drive (Shown in Longboard Set Up) **P-3000C**



**DIRECT LINK** Dual position adjustment for LIGHT or HEAVY feel, creating a seamless link between your foot and the bass drum.



**DEMON DRIVE BEATER** w/ Control Core Elastomer Center. Reduces impact vibration. (U.S. Patent #7626108)



**CLICK-LOCK** Secures spring tension in high impact play. (U.S. Patent #7754953)



**DUO-DECK FOOTBOARD** The world's first convertible footboard can switch from a traditional shortboard to a longboard pedal in seconds. (U.S. Patent #7626107)



**NiNJA BEARINGS** Designed for Pro Skateboarding, each bearing features micro-polished balls for minimal friction and unmatched speed.



**PERFECT CIRCLE CAM** Its racing inspired lines transfer energy from your foot into the head with minimal mass and maximum speed.

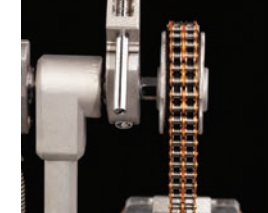

**POWER CHAIN** This ultra lightweight, dual linkage Chain features low friction rollers for power and dependability.



**P-3002C** Chain Drive Double Pedal (Shown In Shortboard Setting)



**Z-LINK DRIVE SHAFT** Delivering the same precise action of the primary pedal in the secondary pedal, the Z-Link features hand assembled, CNC machined construction. Features Pearl's exclusive Zero Latency Universal Joints, and precision radial ball bearings.

# ELIMINATOR: REDLINE

THE KEY TO ULTIMATE BASS DRUM PERFORMANCE



Eliminator Redline Single Pedal, Chain Drive P-2050C

## CHOOSE A CAM REDLINE YOUR PERFORMANCE

The world's only pedal featuring the Patented Interchangeable Cam System, Eliminator Redline's virtually unlimited tunability lets you lock in personally tuned feel, power, and speed. Like having four pedals in one, Redline pushes the boundaries of bass drum performance by fusing the power and flexibility of Pearl's original Eliminator with the fluid speed of our Demon series pedals.

DRIVE	Sprocketless Double Chain
FOOT BOARD	Redline Reversible Traction Plate
DRIVE BEARINGS	NiNjA Low-Friction
BEATER	Control Core Quadbeater
TENSION ADJUSTMENT	Click-Lock
BEATER ANGLE	Uni-Lock Infinitely Adjustable
POWERSHIFTER	Three Position
CASE	Included
HEEL PLATE HINGE	Zero Play (U.S. Patent #7179978)

P-2050C



\*Shown w/ Optional Red Cam

## CHAIN OR BELT DRIVE

The sprocket-less double chain drive on the Eliminator Redline (P-2050C) provides super smooth action with powerful and precise feel. The Eliminator Belt Drive model (P-2050B) provides a very comfortable, natural feel similar to a direct-drive system.

### INTERCHANGEABLE CAM SYSTEM

Provides a choice of 6 different color-coded cams (4 included and 2 more optional). Quickly changes the power and feel of the pedal to suit your individual playing needs. Changing the cam is as simple as pushing the release button and snapping another in place.

<b>BLACK CAMTBK</b>	<b>WHITE CAMTWT</b>	<b>BLUE CAMTBL</b>	<b>RED CAMTRD</b>	<b>PURPLE CAMPL</b>	<b>YELLOW CAMYL</b>
Linear action cam	Oversized linear cam	Progressive cam	Radical progressive cam	Aggressive action cam (Optional)	Inverse action cam (Optional)

DRIVE	Sprocketless Double Chain
UNIVERSAL JOINT	Length Adjustable, Latency-Free
FOOT BOARD	Redline Reversible Traction Plate
DRIVE BEARINGS	NiNjA Low-Friction
BEATER	Control Core Quadbeater
TENSION ADJUSTMENT	Click-Lock
BEATER ANGLE	Uni-Lock Infinitely Adjustable
POWERSHIFTER	Three Position
HEEL PLATE HINGE	Zero Play (U.S. Patent #7179978)

P-2052C

DRIVE	Sprocket-less Double Chain
FOOT BOARD	Redline Reversible Traction Plate
DRIVE BEARINGS	NiNjA Low-Friction
BEATER	Control Core Quadbeater
TENSION ADJUSTMENT	Click-Lock
BEATER ANGLE	Uni-Lock Infinitely Adjustable
POWERSHIFTER	Three Position
CASE	Included
HEEL PLATE HINGE	Zero Play (U.S. Patent #7179978)

P-2050B

DRIVE	Sprocketless Double Chain
UNIVERSAL JOINT	Length Adjustable, Latency-Free
FOOT BOARD	Redline Reversible Traction Plate
DRIVE BEARINGS	NiNjA Low-Friction
BEATER	Control Core Quadbeater
TENSION ADJUSTMENT	Click-Lock
BEATER ANGLE	Uni-Lock Infinitely Adjustable
POWERSHIFTER	Three Position
HEEL PLATE HINGE	Zero Play (U.S. Patent #7179978)

P-2052B



Eliminator Redline Double Pedal, Belt Drive P-2052B

Eliminator Redline Double Pedal Chain Drive (Shown w/ Included Red Cam Attached) P-2052C

Eliminator Redline Series pedals come standard with Custom Carry bags.



**POWERSHIFTER FUNCTION** By moving the foot board forward or back, our revolutionary PowerShifter function provides 3 positions to fine tune the power and feel of the pedal. Instantly change the drive angle leverage to create a light, regular, or strong feel. U.S. Patent #5574237



**ZERO PLAY HINGE** Our proprietary stainless steel hinge provides maximum freedom of motion for blazing speed and prevents play between the footboard and heel. U.S. Patent #7179978



**NINJA BEARINGS** Developed by skateboarding engineers for the ultimate in fast, quiet performance, NiNjA Bearings incorporate state of the art micropolished steel balls for incredibly fast and smooth performance.



**ROLLER HOOP CLAMP** w/ Side Mount Adjustment. Quickly adapts to a wide range of hoop thicknesses for the smoothest, most secure grip possible. Easy side access to the hoop clamp makes set up and tear down a breeze.



**INDEPENDENT TRACTION GRIPS** Eliminator Redline's redesigned pedalboard features Pearl's exclusive reversible Traction Plate insert, allowing individual traction grip configuration to suit your exact playing requirements.



**CLICK-LOCK SPRING ADJUSTMENT** w/ NEW Rotor Tension Cradle. Secures spring tension in high impact play. The counter spring adjustment's rolling cradle allows the spring to pivot with each stroke for less resistance. U.S. Patent #7754953



**THE CONTROL CORE QUADBEATER** Provides four beater surfaces (two hard plastic, two felt) with the added feel of the vibration-free Control Core elastomer center. U.S. Patent #7626108



**UNI-LOCK BEATER ANGLE CAM** Grips the axle a full 360 degrees, allowing infinite beater angle adjustments. Floating Spring Pendulum design is perfectly centered on the clamp for full bearing movement and maximum smoothness.

# ELIMINATOR SOLO

FLY SOLO AND SET YOUR FEET FREE

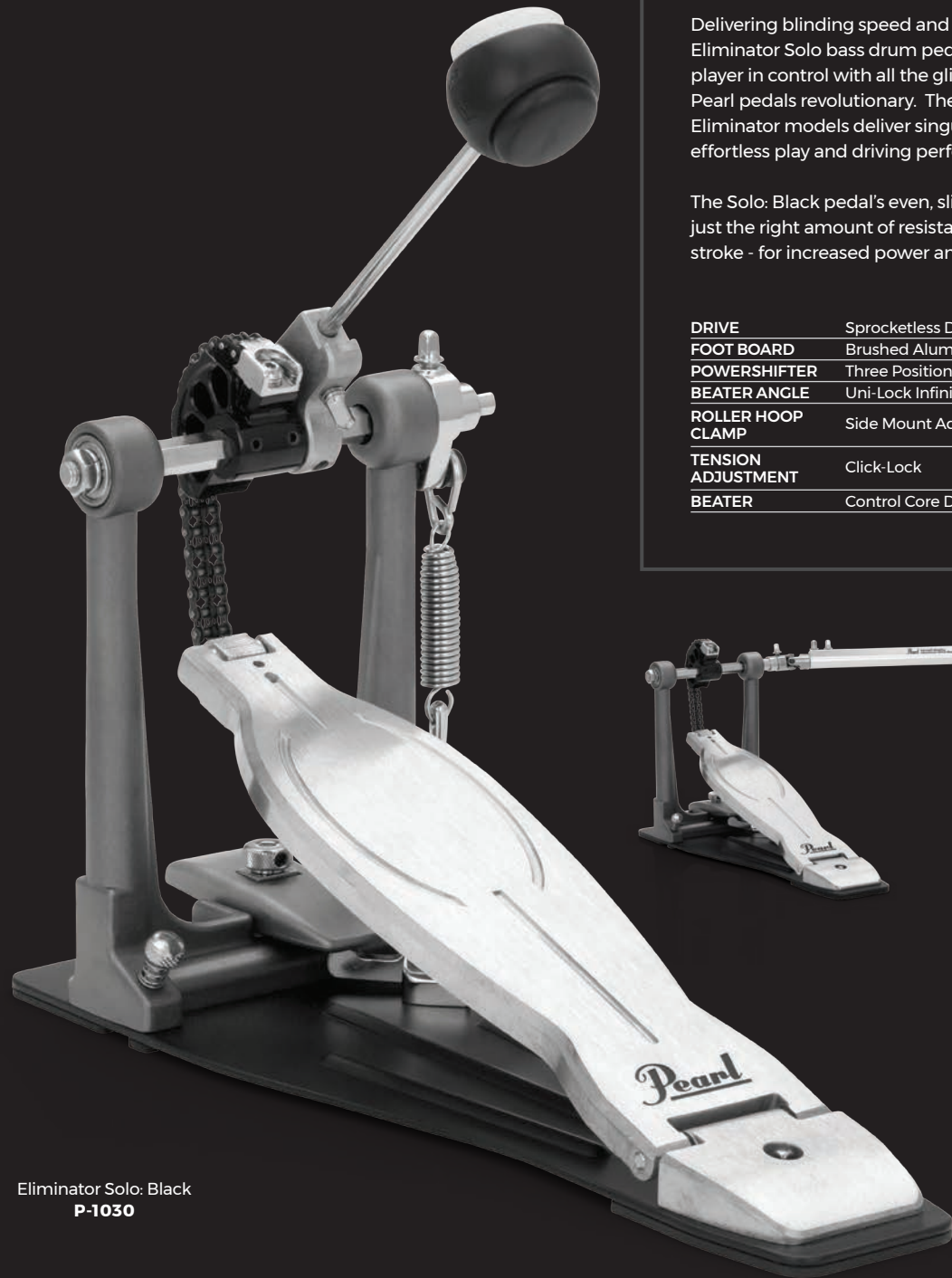

Eliminator Solo: Black  
P-1030

## ELIMINATOR SOLO: BLACK

Delivering blinding speed and powerful performance, Eliminator Solo bass drum pedals put the fleet footed player in control with all the gliding velocity that made Pearl pedals revolutionary. These no nonsense, streamlined Eliminator models deliver singular, resistance free feel for effortless play and driving performance.

The Solo: Black pedal's even, slightly weighted feel delivers just the right amount of resistance without slowing your stroke - for increased power and less muscle fatigue.

DRIVE	Sprocketless Double Chain
FOOT BOARD	Brushed Aluminum
POWERSHIFTER	Three Position
BEATER ANGLE	Uni-Lock Infinitely Adjustable
ROLLER HOOP CLAMP	Side Mount Adjustment
TENSION ADJUSTMENT	Click-Lock
BEATER	Control Core DuoBeater



Eliminator Solo: Black  
Double Pedal  
P-1032

# ELIMINATOR

**SINGULAR FEEL.  
ELIMINATOR SPEED.  
PRICED TO PERFORM.**



Eliminator Solo: Red  
P-1030R

## ELIMINATOR SOLO: RED

Delivering accurate speed and focused performance, the Eliminator Solo: Red bass drum pedal delivers no-nonsense Eliminator feel for the technically decisive player.

Focusing the drive on the accurate feel of the Radical Progressive Action of Eliminator: Redline Red Cam, its shape allows the double chain to better match the motion of your foot. This means smooth movement at the bottom of the stroke with an accelerated PUSH at the top, and quick rebound for reactive doubles.

DRIVE	Sprocketless Double Chain
FOOT BOARD	Brushed Aluminum
POWERSHIFTER	Three Position
BEATER ANGLE	Uni-Lock Infinitely Adjustable
ROLLER HOOP CLAMP	Side Mount Adjustment
TENSION ADJUSTMENT	Click-Lock
BEATER	Control Core QuadBeater

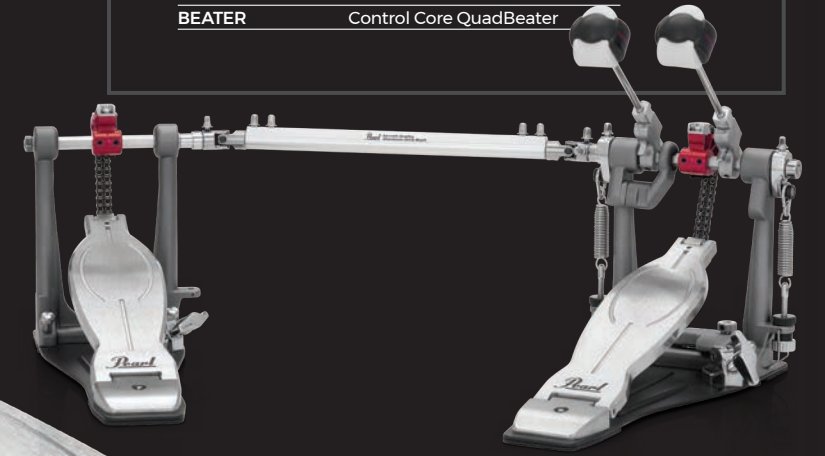

Eliminator Solo: Red  
Double Pedal  
P-1032R



### CONTROL CORE DUOBEATER

Provides hard and soft beater surfaces with the added feel of the vibration free Control Core elastomer center. U.S. Patent #7626108

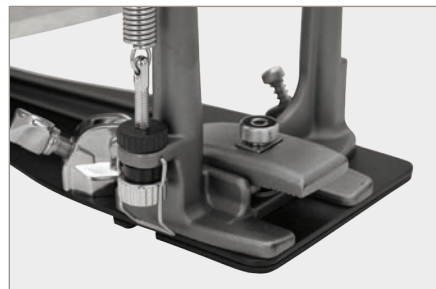

### ROLLER HOOP CLAMP

Features side mount adjustment for easy set-up and tear down. Quickly adapts to a wide range of hoop thicknesses smooth, secure grip.



### CONTROL CORE QUADBEATER

Provides four beater surfaces (two hard plastic, two felt) with the added feel of the vibration-free Control Core elastomer center. U.S. Patent #7626108



### UNIVERSAL JOINT

All Eliminator Solo pedals come with Pearl's adjustable Universal Drive Joint, giving the secondary pedal the feel, power, and unrestrained feel of the main pedal.

# P-930 / P-932 PEDALS

SPEED AND CONTROL FOR THE MASSES

## SUPER SMOOTH, EXTREMELY FAST!

Merging quick rebound response of our flagship Demon Drive with the finely-tuned control of our award-winning Eliminator models, the P-930 bass drum pedal offers high end performance at a player accessible price. Its longboard playing deck delivers a lighter feel for increased speed, and offers advanced performance control and tunability with two rotor cam options. The ultimate pedal for fast feet on a budget.

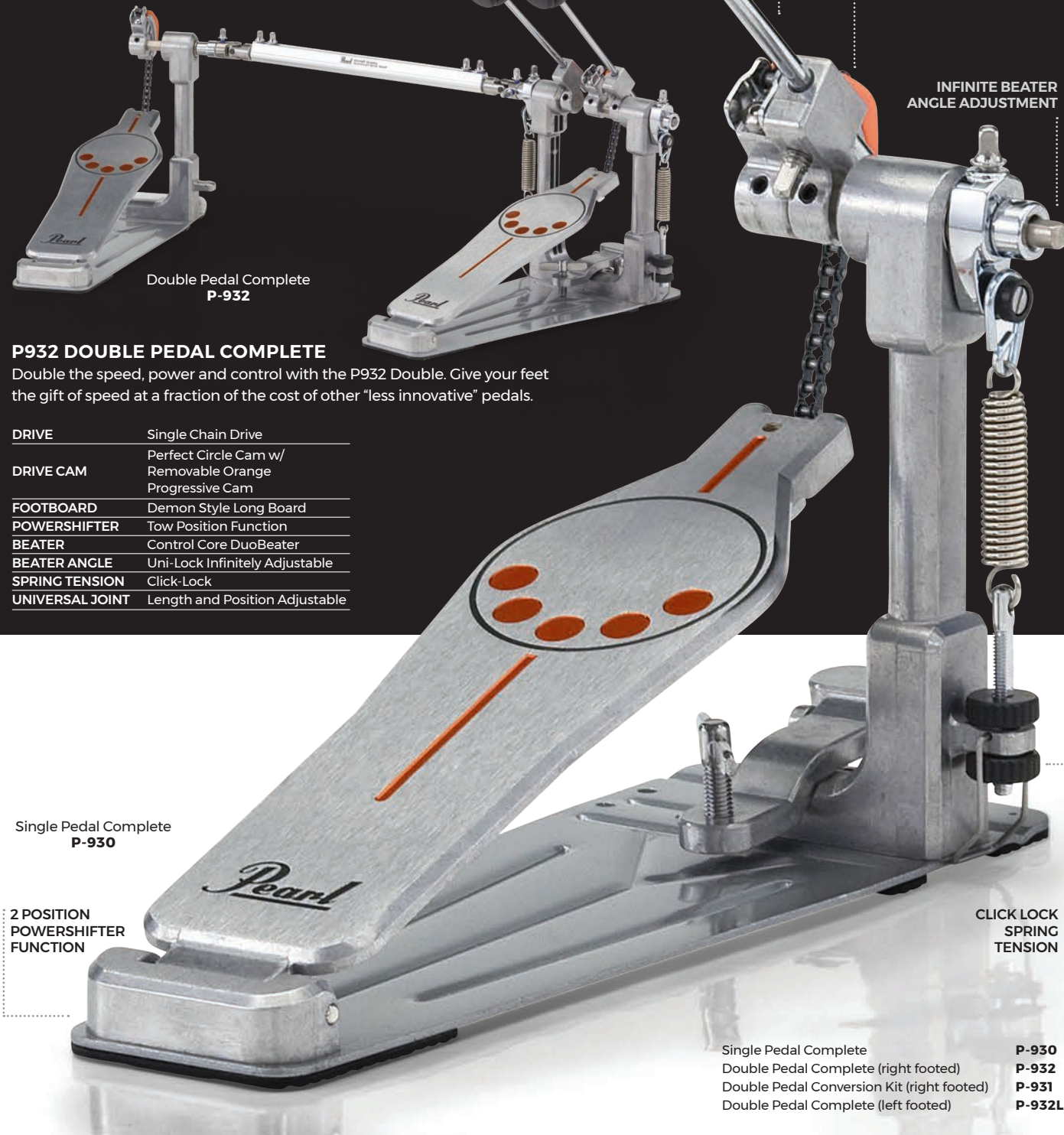

DRIVE	Single Chain Drive
DRIVE CAM	Perfect Circle Cam w/ Removable Eliminator-style Progressive Cam
FOOTBOARD	Demon Style Long Board
POWERSHIFTER	Tow Position Function
BEATER	Control Core DuoBeater
BEATER ANGLE	Uni-Lock Infinitely Adjustable
SPRING TENSION	Click-Lock

Double Pedal Complete  
**P-932**

### P932 DOUBLE PEDAL COMPLETE

Double the speed, power and control with the P932 Double. Give your feet the gift of speed at a fraction of the cost of other "less innovative" pedals.

DRIVE	Single Chain Drive
DRIVE CAM	Perfect Circle Cam w/ Removable Orange Progressive Cam
FOOTBOARD	Demon Style Long Board
POWERSHIFTER	Tow Position Function
BEATER	Control Core DuoBeater
BEATER ANGLE	Uni-Lock Infinitely Adjustable
SPRING TENSION	Click-Lock
UNIVERSAL JOINT	Length and Position Adjustable

Single Pedal Complete  
**P-930**

2 POSITION  
POWERSHIFTER  
FUNCTION

CLICK LOCK  
SPRING  
TENSION

Single Pedal Complete	<b>P-930</b>
Double Pedal Complete (right footed)	<b>P-932</b>
Double Pedal Conversion Kit (right footed)	<b>P-931</b>
Double Pedal Complete (left footed)	<b>P-932L</b>

**ORANGE PROGRESSIVE CAM** can be removed to reveal the Perfect Circle for further tunability to match your playing style. *U.S. Patent #6172291*



The P-930 pedal is included as an upgrade in the 830 Series hardware pack and comes with Export and Export Lacquer drum sets.

**CLICK-LOCK SPRING TENSION** maintains perfect tension gig after gig. Set it and forget it. *U.S. Patent #7754953*



### CONTROL CORE DUO BEATER

*(U.S. Patent #7626108)* utilizes an elastomer center to minimize vibration and features two unique playing surfaces (rounded felt and convex hard plastic surface) for quick-shifting tone and feel.



### POWERSHIFTER FUNCTION

*(U.S. Patent #5574237)* further tunes the power, feel, and leverage of the pedal by shifting the chain angle forward for lighter feel, or back for increased power.

Comes standard with Perfect Circle and removable Orange Progressive Cams, for fully tunable performance and increased control.

## P-530 / P-830

SPEED, POWER, AND VALUE

### P-530 DRUM PEDAL

With all the speed and function of a pro bass drum pedal at half the price, Pearl's P-530 Bass Drum Pedal features a dual chain and Linear Action cam drive for smooth, traditional pedal action and speed.



The radius rod frame makes it highly portable for gigging, while features like a two surface DuoBeater and rotor tension axle clamp make it adaptable to virtually any feel or playing style.

Single Pedal Complete  
**P-530**

### P-830 DRUM PEDAL

Light in weight but not in features, the P-830's Demon-style longboard increases playing surface for maximum leverage and speed. Its fully adjustable beater angle, Perfect Circle single chain cam, and DuoBeat two-surface beater deliver customizable feel for the player on the move.

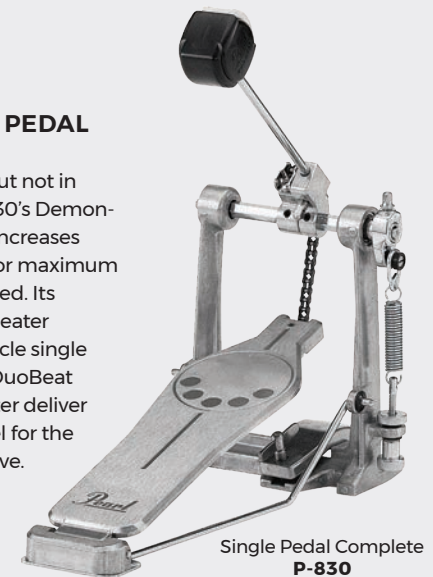

Single Pedal Complete  
**P-830**

# HI-HAT STANDS

BIGGEST ADVANCEMENT IN TIME-KEEPING SINCE THE WRISTWATCH

H-2050

Sharing many of the key characteristics of Pearl's Eliminator Redline bass drum pedals, 2050 Series Hi-Hat Stands deliver unparalleled versatility and customization in hi-hat pedal control. The world's-only hi-hat stand featuring the Interchangeable Cam System, 2050 Series stands' customizable options are designed to eliminate resistance, reduce fatigue, and increase performance.

BRIAN FRASIER-MOORE  
Justin Timberlake



“Night in and night out, Pearl hardware keeps everything right where it should be, and without fail!”  
- OKWA ANDREWS

OKWA ANDREWS  
Brian's Tech

## CLH-930

Closed Hi-Hat  
Uni-Lock Tilter  
Knurled Boom Arm  
Ultragrip Wingnut



## CLA-130

Closed Hi-Hat  
Bass Drum Hoop Mounted  
Side-to-Side, Forward/Back Adjustable  
Ultragrip Wingnut



## CLH-70

Closed Hi-Hat  
Multi-Angle Quickset Clamp  
Gearless UniLock Tilter  
Ultragrip Wingnut



Pearl's Rapid Lock Super Grip's slip-proof clutch system features a patented 360° lock nut that provides vice-like clamping force for a super grip. (U.S. Patent #9355625)



## H-2050

Rapid Lock Super Grip Clutch (U.S. Patent #9355625)  
Hi-Hat Cup (U.S. Patent #7078606)  
Swiveling Legs  
Precision Spring Tension Dial  
PosiLink Twin Cam Drive System with Interchangeable Cams  
Traction Plate Footboard Convertible Spike/Rubber Feet (U.S. Patent #7371953)  
Footboard Docking Station  
PowerShifter  
Height Range of 750-1030mm

The RH2050 Remote Hi-Hat's low-friction cable produces smooth, lag-free performance with the lightning-fast action of the PosiLink Twin Cam drive system. Fast, natural-feeling cymbal play is finally accessible virtually anywhere on the kit, or to facilitate multiple hi-hat system setups.



## RH-2050

Rapid Lock Clutch (U.S. Patent #9355625)  
Direct Pull Drive System  
Infinitely Adjustable Footboard Angle  
Double Braced Tripod w/ Swivel Function  
Spike/Rubber Tips  
Spring Tension Dial  
Hi-Hat Cup (U.S. Patent #7078606)



## H-1050

Rapid Lock Clutch (U.S. Patent #9355625)  
Direct Pull Drive System  
Infinitely Adjustable Footboard Angle  
Double Braced Tripod w/ Swivel Function  
Spike/Rubber Tips  
Spring Tension Dial  
Hi-Hat Cup (U.S. Patent #7078606)  
Height range of 700-960mm

Features Eliminator Solo traditional footboard, double braced swiveling tripod, and gigging weight tubing for touring professionals.



## H-1030

Direct Pull Drive System  
Precision Spring Tension Dial  
Double Braced Tripod w/ Swivel Function  
SureGrip Oversize Rubber Feet  
Smooth Traditional Footboard  
Height range of 760-940mm

Features Eliminator Solo traditional footboard, single braced swiveling tripod, and reduced weight for gigging professionals.



## H-1030S

Direct Pull Drive System  
Precision Spring Tension Dial  
Single Braced Tripod w/ Swivel Function  
Smooth Traditional Footboard  
Height range of 760-940mm



## H-930

Direct Pull Drive System  
Precision Spring Tension Dial  
Double Braced Tripod w/ Swivel Function  
SureGrip Oversize Rubber Feet  
Demon Style Long Board Footboard  
Height range of 760-940mm



## H-830

Demon Style Long Footboard (single color footboard)  
Double Braced Tripod w/ Swivel Function  
Height range of 610-910mm



## H-150S

Light Weight (6.30 lbs.)  
Stable Flat-Based Tripod  
Swivel Function Allows Easy Double-Pedal Positioning  
Direct-Pull Drive System  
Spring Tension Adjustment  
Redline Traction Plate Footboard  
Height range of 745-865mm



**INDEPENDENT TRACTION GRIPS** features Pearl's exclusive reversible Traction Plate and individual traction grips, configurable to suit your individual taste.



**H-2050 PRECISION SPRING TENSION DIAL** allows perfect tension control for fine-tuned response.



**H-1050 PEDAL HEIGHT ADJUSTMENT** The infinite footboard angle adjustment featured on the H-2050 and H-1050 allows precise height matching in multi-pedal setups.



**CLAMSHELL CLAMP** The H-2050, H-1050, H-1030, H-1030S, and H-930 Hi-Hat Stand uses beefy 1" tubing and clamshell clamps with built in memory locks for superior rigidity.



**HA-130** positions your hi-hat next to your bass pedal in double bass set-ups for effortless transitions between pedals.

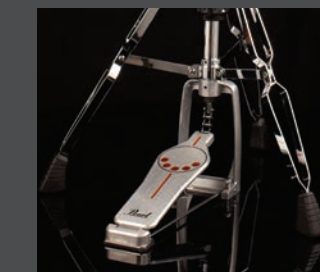

**H-930 HI-HAT STAND** H-930 Hi-Hat Stand features our Demon style longboard, double braced tripod w/ swivel function, and precision tension dial.



**H-830 HI-HAT STAND** H-830 Hi-Hat Stand is standard equipment with our Export series and offers a monochromatic Demon Style longboard design and swivel tripod.



**H-150S\* FLAT-BASED SWIVELING HI-HAT** The H-150S independent tripod is positioned separately from the pedal frame making it the only flat-based hi-hat stand with swiveling legs.

# SNARE STANDS

EVERY SNARE SHOULD BE SO LUCKY

No matter the gig or the drum, Pearl has a stand to accommodate both with security, high function, and chameleon-like diversity.



Essential for extended and efficient performance, the right throne will prevent fatigue and promote great form and posture to keep you playing your best, night after night. Pearl thrones feature advanced ergonomic design and a selection of computer-tempered cushion tops to provide support and ease joint pressure during long sessions.

# DRUM THRONES

SOUND ERGONOMICS

**MULTI-CORE FOAM TECHNOLOGY:** Roadster thrones now feature multiple layers of varied density foam which combine for a better playing foundation and improved feel.



**S-1030**  
CyroLock Tilter: infinite angle adjustability  
Adjustable Snare Basket: Fits Snares 10" - 16"  
Air Suspension Rubber Tips (U.S. Patent #6710236)  
Trident Tripod  
Height Range of 480-700mm  
Oversize Super Grip Rubber Feet



**S-1030D**  
Low Position Snare Stand (Height Range: 360-570mm)  
CyroLock Tilter: infinite angle adjustability  
Adjustable Snare Basket: Fits 10" to 16" drums  
Air Suspension Rubber Tips (U.S. Patent #6710236)  
Trident Tripod  
Oversize Super Grip Rubber Feet



**S-930**  
Uni-Lock Tilter  
Air Suspension Rubber Tips (U.S. Patent #6710236)  
Double Braced Trident Style Tripod  
Fits Snares 10" - 14"  
Height Range of 450-670mm  
Also available as S-930S drop basket version



**S-930D**  
Uni-Lock Tilter  
Air Suspension Rubber Tips (U.S. Patent #6710236)  
Double Braced Trident Style Tripod  
Fits Snares 10" - 14"  
Height Range of 360-570mm



**S-930S**  
Uni-Lock Tilter  
Air Suspension Rubber Tips (U.S. Patent #6710236)  
Single Braced Trident Style Tripod  
Fits Snares 10" - 14"  
Height Range of 420-610mm



**S-830**  
Uni-Lock Tilter  
Double Braced Tripod  
Fits Snares 13" - 14"  
Height Range of 440-650mm  
Standard with Export Series drums, perfect for local gigging and easy transport



**S-150S**  
Light Weight (5.18 lbs.)  
Stable Flat-Based Tripod  
Gearless Uni-Lock Basket Tilter  
Convertible Tripod or Flat-Based Legs  
Instantly convertible from flush-based to standard tripod



**S-1030 / S-1030D SNARE STAND CYROLOCK** Our premier S-1030 / S-1030D model features Pearl's 360 degree infinitely adjustable CyroLock tilter for ease-of-use and pinpoint positioning.



**S-1030 SNARE BASKET** The Pearl S-1030 Snare Stand adjusts to fit virtually any size snare from 10" to 16". The Air Suspension rubber tips securely cradle your prized snares while allowing them to fully resonate. (U.S. Patent #6710236)



**S-1030D / S-930D SNARE BASKET** S-1030D / S-930D Snare Stand is a shorter version of the S930 Snare Stand, and is built to comfortably accommodate deeper snare drums.

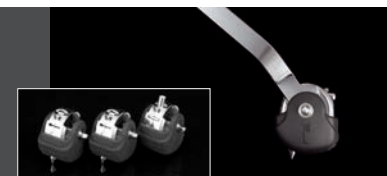

**SPIKED / RUBBER FEET (Sold Separately)** Our CVT-300/3 Push Button Spiked/Rubber Feet come in pack of 3 to retrofit on any of our 1030 Series hardware for sure-footed performance on any terrain. (U.S. Patent #7371953)



**D-3500BR**  
Saddle-Style, Multi-Core Foam Cushion  
Detachable Backrest Mounts via Single Knob  
Lock/Spin System: Reversible StopLock allows cushion to be secured in place or free spinning depending on preference.  
Height Range of 495-665mm



**D-3500**  
Saddle-Style, Multi-Core Foam Cushion  
Accepts Optional Backrest  
Lock/Spin Reversible StopLock System  
Height Range of 495-665mm



**D-1500TGL**  
15" Trilateral Multi-Core Foam Cushion  
Option of a Saddle or Round top feel.  
Accepts Optional Backrest  
Gas Lift Height Adjustment  
Lightweight Aluminum Struts: Solid support with easier transport  
Height Range of 495-695mm



**D-1500RGL**  
15" Round Multi-Core Foam Cushion  
Accepts Optional Backrest  
Gas Lift Height Adjustment  
Lightweight Aluminum Struts  
Height Range 495-695mm



**D-1500SP**  
15" Vented Round Seat  
Multi-Core Foam Donut Cushion  
Accepts Optional Backrest  
Built-In Shock Absorber Post w/ Adjustable Spring Tension  
Lock/Spin Reversible StopLock System  
Height Range of 525-630mm



**D-1500**  
15" Vented Round Seat  
Multi-Core Foam Donut Cushion  
Accepts Optional Backrest  
Lock/Spin Reversible StopLock System  
Height Range 495-665mm



**D-1500S**  
15" Vented Round Seat  
Multi-Core Foam Donut Cushion  
Accepts Optional Backrest  
Lock/Spin Reversible StopLock System  
Height Range 445-615mm



**DTBR-1535**  
12.5" x 7" Optional Backrest  
Formfitting and Breathable  
Removable  
Dual Axis Adjustability



**D-930**  
Round Vinyl Cushion  
Double Braced Legs  
Height Range of 470-660mm



**D-790**  
Round Vinyl Cushion  
Double Braced Legs  
Height Range of 430-650mm



**D-730S**  
Round Vinyl Cushion  
Single Braced Legs  
Height Range of 405-605mm



**D-50**  
Round Vinyl Cushion  
Double Braced Legs  
Height Range of 495 - 620mm



# CYMBAL STANDS

WELCOME TO BOOM TOWN

## FOR EVERY CYMBAL, THERE IS A PLACE.

Advancing Drum Hardware for Serious Working Drummers since 1946. Through constant setup, teardown, performance, practice, and transport, Pearl has you covered with cymbal stand solutions that are ready to endure constant abuse and keep going.

**“ Pearl hardware is literally the only hardware that you'll ever have to buy and it's all backed by their incredible lifetime warranty! ”**

**- TRACY BROUSSARD**  
Blake Shelton



**CLAMSHELL** designed Die Cast joint on 2030, 1030, 930 series Boom and Straight cymbal stands, provides superhuman clamping force. Set your position, lock it down and wail away.

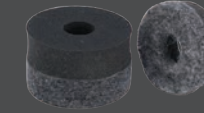

**REVERSIBLE FELT / FOAM CYMBAL WASHERS** allow four-way control of cymbal "ring" by mixing and matching the "hard" and "soft" surfaces of the washers.



**830 SERIES STANDS** offer lighter weight while incorporating many of the 1030 series designs. The tripod uses Trident style design with double braced legs. Large easy to use wingnuts and lateral struts for optimal stability.

The most technically advanced boom stand ever devised. Perfect for studio or live applications.

Reversible Felt/  
Foam Washer



<b>BC-2030</b>	<b>BC-1030C</b>	<b>B-1030</b>	<b>BC-930</b>
CyroLock Tilter	CyroLock Tilter	CyroLock Tilter	Uni-Lock Tilter
WingLoc	WingLoc	WingLoc	Plastic Wingnut
Reversible Cup Washer w/ O-ring	Reversible Cup Washer w/ O-ring	Reversible Cup Washer w/ O-ring	Plastic Cymbal Cup
Die Cast Joint w/ Stop Lock	Trident Tripod	Die Cast Joint	Die Cast Joint
Trident Tripod	Double Braced Legs	Trident Tripod	Trident Style
Double Braced Legs	Built in Percussion Post	Double Braced Legs	Convertible Boom Tilter
Built in Percussion Post	Reversible Felt/ Foam Washer	Built in Percussion Post	Double Braced Leg
Nodal Point Resonance Enhancing System	Height Range of 820-1900mm	Reversible Felt/Foam Washer	Height Range of 830-1800mm
Height Range of 800-2150mm		Height Range of 820-1900mm	

Reduced weight for easy gigging transport.

Offers lighter weight with advanced appointment designs.

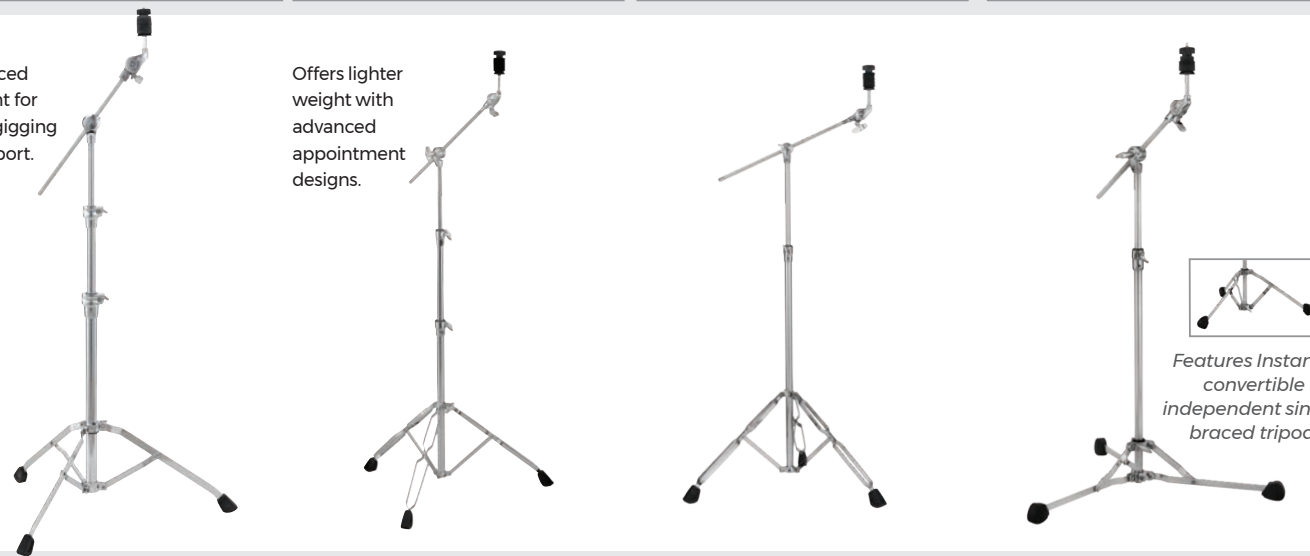

<b>BC-930S</b>	<b>BC-830</b>	<b>BC-820</b>	<b>BC-150S</b>
Uni-Lock Tilter	Uni-Lock Tilter	Uni-Lock Tilter	Light Weight (5.42 lbs.)
Plastic Wingnut	Plastic Wingnut	2 Section Stand	Uni-Lock Tilter
Plastic Cymbal Cup	Plastic Cymbal Cup	Plastic Wingnut	Convertible Single-Braced Tripod
Die Cast Joint	Die Cast Joint	Plastic Cymbal Cup	Convertible Boom Tilter
Trident Style w/ Single Braced Legs	Convertible Boom Tilter	Die Cast Joint	Plastic Wingnut and Cymbal Cup
Convertible Boom Tilter	Double Braced Legs	Convertible Boom Tilter	Reversible Felt/Foam Washer
Height Range of 780-1800mm	Height Range of 780-1480mm	Double Braced Legs	Height Range of 780-1300mm
		Height Range of 900-1740mm	

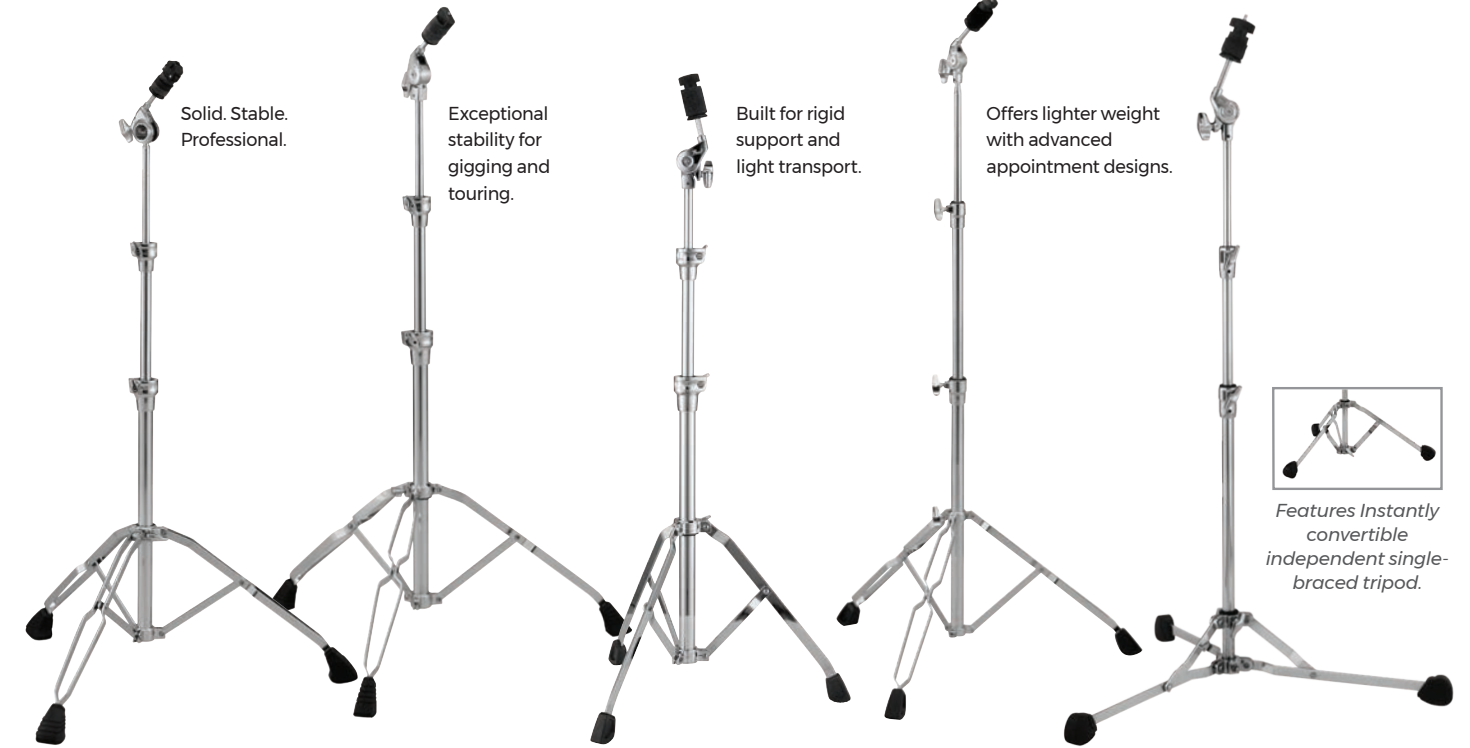

<b>C-1030</b>	<b>C-930</b>	<b>C-930S</b>	<b>C-830</b>	<b>C-150S</b>
CyroLock Tilter	Uni-Lock Tilter	Uni-Lock Tilter	Uni-Lock Tilter	Light Weight (4.80 lbs.)
WingLoc	Plastic Wingnut	Plastic Wingnut	Plastic Wingnut	Uni-Lock Tilter
Reversible Cup Washer w/ O-ring	Plastic Cymbal Cup	Plastic Cymbal Cup	Plastic Cymbal Cup	Convertible Single-Braced Tripod
Die Cast Joint	Die Cast Joint	Die Cast Joint	Die Cast Joint	Plastic Wingnut and Cymbal Cup
Trident Tripod	Trident Style	Trident Style	Double Braced Legs	Reversible Felt/Foam Washer
Double Braced Legs	Double Braced Legs	w/ Single Braced Legs	Height Range of 720-1480mm	Height Range of 670-1350mm
Built in Percussion Post	Height Range of 760-1500mm	Height Range of 780-1480mm		
Height Range of 770-1530mm				

### LIFETIME WARRANTY

Your hardware has to work as hard you do, and Pearl's strong, gig ready stands and appointments are ready for the job.

Featuring world class design and sophisticated, road proven refinements, Pearl Hardware is made to stand up to all the impact the gig can dish out, and backed by the Industry's only Lifetime Warranty.



### THE TRIDENT TRIPOD

uses a full 360° of clamping force via the hinged collar. The inner tube rests in a nylon bushing to prevent metal to metal contact. Heavy duty legs feature lateral bracing for superior ultra quiet rigidity.



**REVERSIBLE CUP WASHER w/ O-RING (U.S. Patent #6940006)** Specially designed to "float" normally or "lock" to prevent noise during recording.



**WINGLOC** Quick Release Wing Nut (U.S. Patent #6884015) Secure, adjustable, spring loaded cymbal nuts for quick set up and tear down.



### NODAL POINT MARKINGS

Pearl's BC-2030 features markings on the telescopic tubes that allow cymbals to achieve better clarity and sustain when the tubes are positioned at their respective Nodal Points. (U.S. Patent #9070348)



**CYROLOCK TILTERS** are infinitely adjustable and provide 360 degree range of motion for precise positioning with one-step convenience.

# ICON RACK SYSTEM

THE ORIGINAL DRUM RACK, EXPANDED

**RACKS** Preconfigured single and three-sided rack packages the upgraded rotating support foot.



Developed in 1983 with legendary TOTO drummer Jeff Porcaro, Pearl's original DR-1 Drum Rack was the first freestanding, frame based drum support system available.

Now, Pearl expands the ICON (short for Independent CONTROL) Rack system with a fresh selection of upgrades and high function mounting options.



3-Sided Rack (\*also available DR-008 Expansion Bar)  
**DR-80**

<b>INCLUDES</b>	PC-8 Pipe Clamps (x4)
<b>RACK BAR</b>	Black Anodized Aluminum 38mm Square, 91cm Length
<b>RACK LEG</b>	Black Anodized Aluminum 1.5" Diameter, 70.5cm Height



Curved Drum Rack Expansion Bar w/ Support Leg  
**DR-511C**

<b>RACK RAIL</b>	Pearl 40mm Square Anodized Aluminium
<b>SUPPORT LEG/FOOT</b>	34"x2.5" Round Chrome w/ P-38475TA Rotating Foot
<b>USABLE RAIL AREA</b>	44" (46" From Center of Right to Left Clamp)



Single Drum Rack, Straight  
(w/ PCX-100 (x2) & PCL-100 (x2))  
**DR-511**

<b>MAIN SUPPORT RAIL</b>	Brushed Aluminum, 40mm Square
<b>MOUNTING CLAMPS</b>	PCX-100 Clamps (x2) Fits 1/2" to 1 1/8"
<b>RACK RAIL LENGTH</b>	38" (From Center of Right to Left Clamp) 36" (Usable Area)
<b>RACK PIPE/LEG</b>	Steel 1.5" / 3.8cm Diameter, 34" / 86.5cm Height
<b>SUPPORT FOOT</b>	Rotating 1.5" Round w/ TLJ-200 T-Clamp (P-38475TA)
<b>PIPE CLAMPS</b>	PCL-100 (x2) Accepts 7/8" Diameter Arms



Single Drum Rack, Curved  
(w/ PCX-100 (x2) & PCL-100 (x2))  
**DR-511C**

<b>MAIN SUPPORT RAIL</b>	Brushed Aluminum, 40mm Square
<b>MOUNTING CLAMPS</b>	PCX-100 Clamps (x2) Fits 1/2" to 1 1/8"
<b>RACK RAIL LENGTH</b>	46" (From Center of Right to Left Clamp / 44" (Usable Area)
<b>RACK PIPE/LEG</b>	Steel 1.5" / 3.8cm Diameter, 34" / 86.5cm Height
<b>SUPPORT FOOT</b>	Rotating 1.5" Round w/ TLJ-200 T-Clamp (P-38475TA)
<b>PIPE CLAMPS</b>	PCL-100 (x2) Accepts 7/8" Diameter Arms



Straight Drum Rack Expansion Bar w/ Support Leg  
**DR-511E**

<b>RACK RAIL</b>	Pearl 40mm Square Anodized Aluminium
<b>SUPPORT LEG/FOOT</b>	34"x2.5" Round Chrome w/ P-38475TA Rotating Foot
<b>USABLE RAIL AREA</b>	36" (38" From Center of Right to Left Clamp)



Three-Sided Drum Rack, Straight  
(w/ PCX-100 (x4) & PCL-100 (x2))  
**DR-513**

<b>RACK RAILS</b>	Pearl 40mm Square Anodized Aluminium
<b>SUPPORT LEGS/FEET</b>	38"x2.5" Round Chrome w/ P-38475TA Rotating Foot
<b>INCLUDED RAIL CLAMPS</b>	PCX-100 (x4)
<b>INCLUDED PIPE CLAMPS</b>	PCL-100 (x2)
<b>USABLE RAIL AREA</b>	36" (38" from Center of Right to Left Clamp)



Three-Sided Drum Rack, Curved  
(w/ PCX-100 (x4) & PCL-100 (x2))  
**DR-513C**

<b>RACK RAILS</b>	Pearl 40mm Square Anodized Aluminium
<b>SUPPORT LEGS/FEET</b>	38"x2.5" Round Chrome w/ P-38475TA Rotating Foot
<b>INCLUDED RAIL CLAMPS</b>	PCX-100 (x4)
<b>INCLUDED PIPE CLAMPS</b>	PCL-100 (x2)
<b>USABLE RAIL AREA</b>	36" (38" from Center of Right to Left Clamp)



Drum Rack Moveable Support T-Leg  
**DR-110T**

<b>SUPPORT LEG/FOOT</b>	34"x2.5" Round Chrome w/ P-38475TA Rotating Foot
-------------------------	--------------------------------------------------



**MASTERWORKS CUSTOM KIT**  
in Satin White Lacquer with Piano Black Stripes, Black Chrome Hardware



**DMP927SP/C #229 WHITE SATIN PEARL**  
with 20" Gong Drum on two ICON straight racks



**REFERENCE PURE #102 NATURAL MAPLE**  
To find out about this and other ICON RACK RECIPES, go to [www.pearltrackrecipes.com](http://www.pearltrackrecipes.com)

# RACK ACCESSORIES

AN INDUSTRY ICON - THE PROFESSIONAL'S CHOICE

## ICON RACK RECIPES

Check out Pearl's ICON Rack Recipe videos at [www.pearlrackrecipes.com](http://www.pearlrackrecipes.com) for step-by-step instructions on how to get the most from existing and available Pearl Rack parts.

## MOUNTING CLAMPS

Developed for the slip resistant ICON square rack rail and round support pipe. Each dramatically increases the level of setup flexibility and function variety.



Expandable Pipe Clamp  
Fits All Icon Rack Leg Posts  
**PC-L100**

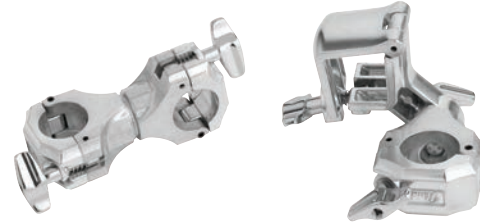

Dual Pipe Clamp  
**PCR-100**

Pipe To Rail Clamp  
**PCR-200**

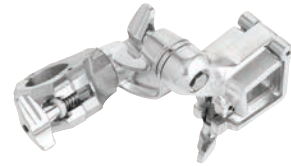

Pipe To Rail Clamp  
**PCR-200L**



Rotating Pipe Accessory Clamp  
**PCR-50X**



Pipe Accessory Clamp  
**PCR-50L**

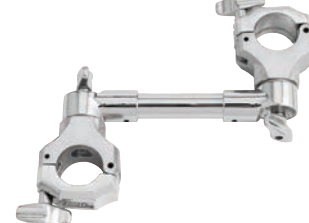

Rotating Dual Pipe Clamp  
**PCR-50R**



Curved Rack Rail  
Short w/ Clamp  
**AL-86AC**



Curved Rack Rail  
Medium w/ End Caps  
**AL-103A**



Icon Support Foot  
w/ TLJ-200 T-Clamp  
**P-38475TA**



Rail Accessory Clamp  
Clamp System  
w/ Adjustable Jaw  
**PCX-100**



Rotating Rail Accessory Clamp  
Tilting Clamp System  
w/ Adjustable Jaw  
**PCX-200**



Extended Rotating  
Rail Accessory Clamp  
**PCX-300**



Pipe Clamp  
Fits 7/8" tubes, for DR80  
**PC-8**



Icon  
6" Mini-Expansion Bar  
**RJ-50**



Pipe Joint  
**RJ-100**



2 Clamps  
Fits 5/8" to 1-1/8"  
**ADP-20\***

2 Revolving Clamps  
Fits 1/2" to 1-1/8"  
**AX-25\***

2 Revolving Clamps  
Fits 1/2" to 1-1/8"  
**AX-25L\***

In-Line & Revolving Clamps  
Fits 5/8" to 1-1/8" & 1/2" to 1-1/4"  
**AX-28\***

3 Adjustable Clamps  
Fits 3/8" to 1-1/4"  
**ADP-30\***

# TOM STANDS / ARMS

POSITIONING POSSIBILITIES NEVER BEFORE ATTAINABLE



**GYROLOCK**



**UNI-LOCK**



**GEAR TILTER**

Our T/TC-1030 Series features our GyroLock tilter for an infinite 360 degree range of movement. The T/TC-930 Series use our Uni-Lock tilter for 180 degrees of motion. Our TH-88 and TH-70 Tom Arms Series use our dependable gear tilter.



**T-1030**

**T-930**

**TC-1030B**

**TC-930**



**CHB-75CA**

**CHB-75LB**

**CH-1030B**

**CH-930**

**CH-830**

Mic Holder  
**MH-830**



**CH-1030BS**

**CH-930S**

**CH-830S**



Boomerang Curved Boom  
Arm with Clamp and Tilter  
**CHC-200**



Boomerang Curved  
Cymbal Boom Arm  
**CHC-100**



Curved Cymbal Holder  
**CH-1030C**

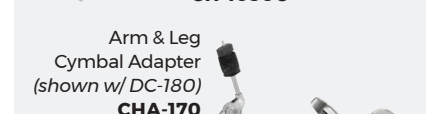

Arm & Leg  
Cymbal Adapter  
(shown w/ DC-180)  
**CHA-170**



Two Way  
Arm Clamp  
**DCA-180**



Boom Arm  
Cymbal Holder  
**CH-70**



Mic Holder  
**MH-70A**



**TH-1030**

**TH-1030S**

**TH-1030I**

**TH-900S**

**TH-900I**

**TH-88S**

**TH-88I**

**TH-70S**

**TH-70I**



**UX-80S**

**UX-80**

Features rotating infinitely adjustable clamps for multiple uses.

13" Tube Height  
Extender  
**TX-100**

Accepts 7/8" dia. tubes. Ideal for extending snare stand height.



Tube Extender  
for 1" Pipe  
**TX-125**

Accepts 1" dia. tubes. Ideal for extending travel conga stands.



Chrome Multi Bass Drum Legs  
**PM-BDL3/C**

Multi-Bass Drum Legs allow any bass drum to be played horizontally. Height and tilt adjustable.



Bass Drum Mount Cymbal Holder  
**CHB-830**

Mounts directly to the bass drum.

# PEARL PERCUSSION ARTISTS



**AARON DRAPER**  
John Mayer / Eminem / Adele

**ALAIN PEREZ**  
Alain Perez

**ANDY FARAG**  
Umphreys McGee

**ARCHIE PENNA**  
Shakira

**BOBBY ALLENDE**  
Tito Nieves

**BRETT BAKER**  
Rihanna / Jay-Z



**CAMILO QUINONES**  
El Dusty

**CARLITO SOTO**  
Willie Colon

**CARLITOS PADRON**  
Rumberos Del Callejon

**CESAR ESPINOZA**  
Orchestra Tobacco Y Ron

**COLIN DOUGLAS**  
Aerosmith

**CHRISTIAN PEPIN**  
Independent



**DIMAS SANCHEZ**  
Fusion Beat / Trilogy Latin Jazz

**DOMINIQUE THOMAS**  
John Legend / Jill Scott

**EMRAH KOTAN**  
Independent

**ETTIENNE FUENTES**  
Independent

**HORACIO HERNANDEZ**  
Independent

**JESSIE CARABALLO**  
Marc Anthony



**JESUS DIAZ**  
Independent

**JOSE ROSA**  
Independent

**LALO DAVILA**  
MTSU

**MARC QUINONES**  
The Doobie Brothers

**MARCO "ITO" ARGUINZONI**  
Independent

**MARVIN DIZ**  
Independent



**OG**  
Slightly Stoopid

**OMAR LEDEZMA**  
Independent

**PAPO PEPIN**  
N.Y. Conga Legend

**RAFA PEREIRA**  
Janelle Monae

**RAVI JAKHOTIA**  
Ravi Drum

**ROBERTO VIZCAINO JR.**  
Orquesta Akokan



**ROLANDO MORALES MATOS**  
The Lion King / Curtis Institute

**SAMMY FIGUEROA**  
Master Percussionist

**SAMMY GARCIA**  
Independent

**TRILOK GURTU**  
Independent

**VALERIE DEE NARANJO**  
Saturday Night Live Band

**ZIG WALJER**  
Hands-On With Zig

# SIGNATURE CONGAS & BONGOS

THE PROS PLAY PEARL!

## BOBBY ALLENDE FIBERGLASS CONGAS AND BONGOS



#617 Confetti  
Signature Fiberglass Congas and Bongos

**CONGAS**  
PCF-110DXBA 11" QUINTO  
PCF-117DXBA 11.75" CONGA  
PCF-125DXBA 12.5" TUMBA  
**BONGOS**  
PBF-300DXBA 7" & 8.5"

Bobby Allende is a mainstay in the New York Latin Music Scene and he demands the best from his drums, that's why he plays Pearl. Bobby demands the best, so he designed his Signature Congas and Bongos to exceed all existing standards, right down to the smallest details. For example, the seams are invisible thus giving his Fiberglass congas the look of wood. The beauty of these drums is more than skin deep, the thick fiberglass shells produce a rich tone and projection sure to get you noticed. The congas stand 28" tall to fit the traditional seated player and the wider base adds even more projection and stability. The superior rim design of the polished Contour Crowns on both the congas and bongos adds significant comfort for the player while complimenting the Remo heads. The drums feature a new super high gloss lacquer in #617 Confetti, personally designed by Bobby.



<b>SHELL</b>	Seamless Fiberglass
<b>HEADS</b>	Remo Fiberskyn3
<b>RIMS</b>	Low-Rider Contour Crown
<b>HARDWARE</b>	Brushed Steel
<b>FINISH</b>	#617 Confetti
<b>BONGOS</b>	PBF-300DXBA
<b>OPTIONAL BAGS</b>	PSC-110CG 11" Quinto Conga Bag PSC-117CG 11.75" Conga Bag PSC-125CG 12.5" Tumba Conga Bag

## JESUS DIAZ SIGNATURE OAK CONGAS AND BONGOS



#580 Brushed Platinum  
Natural Buffalo Skin Heads

**CONGAS**  
PCW-110DXPJD 11" QUINTO  
PCW-117DXPJD 11.75" CONGA  
PCW-125DXPJD 12.5" TUMBA  
**BONGOS**  
PBW-300DXJD 7" & 8.5"

Cuban born Jesus Diaz is one of the most in demand percussionists and vocalists on the scene today. His active schedule provided the feature set for his signature series of congas and bongos. Designed for the seated player the Thai Oak drums measure 30" tall and from the Quinto to Tumba feature added girth to the belly of the drum. Seated conga players typically have to tilt the drum to achieve the desired projection, but the Jesus Diaz drums feature a 4" port on the front of the drum that is strategically positioned to deliver the maximum base frequency while the drum remains flat on the floor.



The drums also feature a newly designed Quick Release lug that is slotted to allow removal of the tension rod without fully removing the nut. A new ergonomically friendly design reduces the impact to your hands while an internal ring centers the head for accurate placement.

<b>SHELL</b>	Thai Oak
<b>HEADS</b>	Buffalo Skin
<b>RIMS</b>	Low-Rider Contour Crown
<b>HARDWARE</b>	Quick Release Lugs Brushed Steel Finish
<b>FINISH</b>	#580 Brushed Platinum
<b>BONGOS</b>	PBW-300DXJD
<b>OPTIONAL BAGS</b>	PSC-110CG 11" Quinto Conga Bag PSC-117CG 11.75" Conga Bag PSC-125CG 12.5" Tumba Conga Bag

# CONGAS & BONGOS

TOOLS OF THE TRADE



## ELITE SERIES



**ELITE WOOD-FIBER CONGAS**  
**PWFC-110DX** - 11" QUINTO  
**PWFC-117DX** - 11.75" CONGA  
**PWFC-125DX** - 12.5" TUMBA

SHELL	Blended, Thai Oak over Fiberglass
HEADS	Natural Cow Skin
RIMS	Contour Crown
HARDWARE	Brushed Steel
FINISH	#648 Dark Chocolate

**ELITE WOOD-FIBER BONGOS**  
**PWFB-100DX** - 7" & 8.5"



**ELITE OAK CONGAS**  
**PCW-110DX** - 11" QUINTO  
**PCW-117DX** - 11.75" CONGA  
**PCW-125DX** - 12.5" TUMBA

SHELL	100% Thai Oak
HEADS	Premium Natural Cow Skin
RIMS	Contour Crown
HARDWARE	Chrome
FINISH	#504 Mocha Burst

**ELITE OAK BONGOS**  
**PBW-300DX** - 7" & 9"



**ELITE OAK CONGAS**  
**PCW-110DX** - 11" QUINTO  
**PCW-117DX** - 11.75" CONGA  
**PCW-125DX** - 12.5" TUMBA

SHELL	100% Thai Oak
HEADS	Premium Natural Cow Skin
RIMS	Contour Crown
HARDWARE	Brushed Steel
FINISH	#510 Caramel Brown

**ELITE OAK BONGOS**  
**PBW-300DX** - 7" & 9"



**ELITE OAK CONGAS**  
**PCW-110DX** - 11" QUINTO  
**PCW-117DX** - 11.75" CONGA  
**PCW-125DX** - 12.5" TUMBA

SHELL	100% Thai Oak
HEADS	Premium Natural Cow Skin
RIMS	Contour Crown
HARDWARE	Chrome
FINISH	#506 Merlot Burst

**ELITE OAK BONGOS**  
**PBW-300DX** - 7" & 9"



**ELITE FIBERGLASS CONGAS**  
**PCF-110DXA** - 11" QUINTO  
**PCF-117DXA** - 11.75" CONGA  
**PCF-125DXA** - 12.5" TUMBA

SHELL	Fiberglass
HEADS	Premium Natural Cow Hide
RIMS	Contour Crown
HARDWARE	Brushed Steel
FINISH	#641 Blue Sparkle Burst

**ELITE FIBERGLASS BONGOS**  
**PBF-300DXA** - 7" & 9"



**ELITE OAK CONGAS**  
**PCW-110DXG** - 11" QUINTO  
**PCW-117DXG** - 11.75" CONGA  
**PCW-125DXG** - 12.5" TUMBA

SHELL	100% Thai Oak
HEADS	Premium Natural Cow Skin
RIMS	Contour Crown
HARDWARE	Gold
FINISH	#535 Satin Black

**ELITE OAK BONGOS**  
**PBW-300DXG** - 7" & 9"

Also available in #532  
Cherry Eucalyptus

## HAVANA SERIES

The wide belly shape of these high end, fiberglass drums produce deeper low tones and greater volume.



SHELL	Fiberglass
HEADS	Natural Cow Skin
RIMS	Contour Crown
HARDWARE	Chrome
FINISH	#644 Liquid Gold

**HAVANA CONGAS**  
**PCF-110HV** - 11" QUINTO

**PCF-117HV** - 11.75" CONGA

**PCF-125HV** - 12.5" TUMBA

**HAVANA BONGOS**  
**PBF-300HV** - 7" & 8.5"



SHELL	Fiberglass
HEADS	Natural Cow Skin
RIMS	Contour Crown
HARDWARE	Chrome
FINISH	#187 Silver White Swirl



SHELL	Fiberglass
HEADS	Natural Cow Skin
RIMS	Contour Crown
HARDWARE	Gold
FINISH	#651 Red Tiger Stripe

## PRIMERO PRO

PCF302DXG26 #626 Gold Marble



Pearl's ever-popular Primero Pro congas and bongos are designed with professional features at an affordable price. Our expanded range of sizes offers 10" & 11" and 11.75" & 12.5" sets in both Thai Oak and Fiberglass with matching bongos.

## PRIMERO PRO FIBERGLASS



11.75" & 12.5" Conga Set #628 Blue Marble  
 Shown with matching bongos  
**PFC-302DX**



12" Conga #621 Wine Red Marble  
 10" & 11" Conga Set #621 Wine Red Marble  
**PFC-202DX**



7" & 8.5" Bongos #523 Carbon Vapor  
 11.75" & 12.5" Congas #523 Carbon Vapor  
**PWB-100DX** **PWC-302DX**

**PRIMERO PRO FIBERGLASS**  
**PFC-302DX** (11.75" & 12.5" Conga Set)  
**PFC-202DX** (10" & 11" Conga set)

SHELL	Fiberglass
HEADS	Buffalo Skin
RIMS	Contour Crown
HARDWARE	Brushed Steel
FINISH	#621 Wine Red Marble #626 Gold Marble #628 Blue Marble

Offer added durability of fiberglass and are louder drums with a crisper sound than wood.

**PRIMERO PRO OAK**  
**PWC-302DX** (11.75" & 12.5" Conga Set)  
**PWC-202DX** (10" & 11" Conga set)

SHELL	Thai Oak
HEADS	Buffalo Skin
RIMS	Contour Crown
HARDWARE	Brushed Steel
FINISH	#511 Natural #521 Midnight Fade #523 Carbon Vapor

Primero Pro wood congas are made with Thai Oak and produce a warm, rich tone.

## PRIMERO



10" & 11" Conga Set w/ PC-300 Stand  
**PFC-203**

Primero Series congas and bongos are available with fiberglass shells and in packages that include a double stand (PC300W) or without stands.



10" & 11" Conga Set  
**PFC-202**

SHELL	Fiberglass
HEADS	Buffalo Skin
RIMS	Contour Crown
HARDWARE	Black Powder Coat
FINISH	#602 Bistre Black

## FIELD PERCUSSION



Weather resistant fiberglass body that delivers a thunderous low-end tone. Remo Nuskyn heads.

10" & 11" Congas  
 #649 Textured Black  
**PFC-202EDU**

## CONGA RESO-PLATE



Designed for the seated conga player, Pearl's Reso-Plate will give you that hard surface desired for maximum resonance. Configured with a cutout handle, the plates can also easily be placed on top of your drums for extra protection when packed in your conga case.

Conga Reso-Plates  
**PRP-140**

# TRAVEL

## CONGAS, BONGOS, & TIMBALES



Where can you take the Pearl Travel Congas and Bongos? The answer is anywhere you can take traditional drums but without any of the hassle. The Travel Congas feature a 3.5" deep wood shell with stave construction and Remo Symmetry heads. Available in three sizes: 11" x 3.5", 11.75" x 3.5" and 12.5" x 3.5" each with five precision Allen bolts. The 7" and 8.5" Travel Bongos feature 3.5" Thai Oak shells with Remo Fiberskyn heads and three point tuning. The Travel Congas and Bongos include a foam-handle tuning wrench.

11.75" Travel Conga  
#510 Caramel Brown  
**PTC-1175N**

12.5" Travel Conga  
#510 Caramel Brown  
**PTC-1250N**

11" Travel Conga  
#510 Caramel Brown  
**PTC-1100N**

Travel Conga Bag  
**PSC-1175C**

Travel Bongos Bag  
**PSC-785TB**

The optional Travel Conga Stand works with all three size drums and features a tension lever mounting system that locks the drum into place. The wide based, double braced legs provide a solid foundation for your drum and prevents the stand from moving during performance.

Travel Bongos  
#510 Caramel Brown  
**PTB-785**

Travel Conga Stand  
w/ Carrying Bag  
**PC-800TC**

Travel Bongos Stand  
**PC-800TB**  
**PC-800TBS** (Short)

Travel Timbales 14" & 15"  
with Stand\*  
**PTTM-1415**

\*Bag sold separately

The Pearl Travel Timbales feature 14" and 15" steel shells that are professional size in diameter but only 4" deep.

The drums are connected by a hinge that marries them to the Quick Release stand. The custom hinge allows the drums to be folded together into the size of one standard depth timbale for easy storage and transportation.

The Travel Timbales come with and a single braced stand that includes an 11.25" adjustable accessory post with 6 positions that allow cowbells and blocks to be placed the perfect distance from the player.

The steel shells feature a black lacquer finish and USA Remo clear Ambassadors heads for a truly professional sounding instrument. A soft carrying case for the stand is also included (sold separately).

# TIMBALES

BUILD THE RIGHT RIG FOR THE GIG!



Primero  
13"x7" Steel Timbale  
w/ PPS36 Mount  
**PTE-1336**

Flat Timbale w/ I.S.S.  
13"x3" Steel  
**PTE-3131**

Flat Timbale w/ I.S.S.  
13"x3" Brass  
**PTB-3131**

**BANDA SERIES**

Banda Timbales  
15"x10" / 16"x10" Steel  
w/ Tilting Stand  
**PBTM-1516/C**

Banda Tambora  
24"x18" Bass w/ Cymbal  
Mount, Stand & Mallet  
**PBTB-2418/C33**

Tilting Timbale  
Stand (Short) Height  
Range 26.5" to 36.5"  
**PT-900WS**

Primero Timbales  
13"x6.5" / 14"x6.5" Steel  
w/ PT-900 Tilting Stand  
(Stands & Cowbell Included)  
**PTS-5134**

Primero Pro Timbales  
14"x7" / 15"x7" Steel  
w/ PT-900 Tilting Stand  
(Sticks Included.  
Cowbell Not Included.)  
**PTE-1415DX**

Marc Quiñones  
Signature Timbales  
14"x7" / 15"x7" Steel  
w/ PT-900 Tilting Stand  
and PBL30 Clave Block  
(Cowbell Not Included)  
**ETE-1415MQ**

# COWBELLS

HORACIO HERNANDEZ  
Independent

**AGOGO & TRIBELLS**

Tri-Bells  
**PTB-30**

Hand-Held  
Agogo  
**ECB-22**

Mounted  
Agogo  
**ECB-23**

**AGOGO & TRIBELLS**

Tri Agogo  
**PTA-30**

Pro  
Cowbell Beater  
**PDC-60**

Dual  
Cowbell Beater  
**PDC-10**

**HORACIO HERNANDEZ SIGNATURE COWBELLS**

Pearl and Grammy Award winning artist Horacio Hernandez have developed the ultimate family of cowbells. The HH-4XH bell features a quick release system that allows the bell to lift easily off of its mount for hand held playing.

Marybell  
**HH-5**

Hand-Held Campana  
Quick Release  
**HH-4XH**

Isabell  
Mambo Bell  
**HH-4**

Chabella  
**HH-3**

Clabell  
**HH-2**

Bella  
**HH-1**

**NEW YORKER BELLS**

Cha-Cha (High)  
**BCM-3NY**

Cha-Cha (Low)  
**BCM-5NY**

Mambo  
**BCM-7NY**

Marc Quiñones  
Sig. Timbale Bell  
**BCM-8NYQ**

Mounted  
Campana Bell  
**BCM-10**

Hand-Held  
Campana Bell  
**BCH-10**

**BALA BELLS**

10" Bell w/ PPS30  
**PCB-1030**

6" Bell  
**PCB-6**

4" Bell  
**PCB-4**

8" Guiro Cowbell  
**PCB-10GR**

10" Millennium Chrome Bell  
**PCB-10MCR**

10" Anarchy Bell  
**PCB-20**

# DJEMBES

ANCIENT INSTRUMENTS FOR THE MODERN PERCUSSIONIST

**DJEMBES** Djembes are a traditional African instrument that offer a wide variety of sounds and are perfect for drum circles. The Professional Elite Series is available in Oak (12.5" diameter) and Fiberglass (12.5" and 14" diameter). All feature our Contour Crowns for comfortable playing and authentic Goat skin heads for deep lows and crisp highs.

#696 PURPLE HAZE  
Top Tuned Djembes



8" x 16" PBJV-8	10" x 19.5" PBJV-10	12" x 24" PBJV-12	14" x 25.5" PBJV-14	14" x 25.5" PBJV-14	12" x 24" PBJV-12	10" x 19.5" PBJV-10	8" x 16" PBJV-8
--------------------	------------------------	----------------------	------------------------	------------------------	----------------------	------------------------	--------------------

#697 TRIBAL FIRE  
Top Tuned Djembes

#698 ZEBRA GRASS  
Rope Tuned Djembes



7" x 12.5" PBJVR-7	10" x 19.5" PBJVR-10	12" x 24" PBJVR-12	14" x 25.5" PBJVR-14	14" x 25.5" PBJVR-14	12" x 24" PBJVR-12	10" x 19.5" PBJVR-10	7" x 12.5" PBJVR-7
-----------------------	-------------------------	-----------------------	-------------------------	-------------------------	-----------------------	-------------------------	-----------------------

#699 MOLTEN SCARLET  
Rope Tuned Djembes



<b>Ez Tune Djembe</b>		<b>Field Percussion Djembe</b>	<b>Elite Oak Djembe</b>	<b>Elite Fiberglass Djembe</b>	<b>Fiberglass Fun Drum</b>
14" (Oak)	12.5" (Oak)	14" (Fiberglass)	14" (Fiberglass)	12.5"	#602 Bistre Black
#533 Gloss Black	#632 Cranberry Fade	#649 Textured Black	#511 Natural	#602 Bistre Black	PJF-350 14"
PJW-140R	PJW-125R	PJF-320RX	PJF-350RX2	PJF-320 12.5"	PJF-320 12.5"
					PFD-300



12" Hand Carved Mahogany Djembe  
#695 Malinke Village  
PBJWR-12



Djembe Stand - Fits 8" to 14" Pearl Rope Tuned And Top Tuned Djembes  
PBJ-STD



Djem-Bass  
PJBS-350

**DJEM-BASS** The PJBS-350 Djem-Bass Attachment allows you to convert any Pearl 14" djembe into a sub-sonic bass drum. To reduce the attack and add greater "lows," we have included a cloth cap that stretches around the head. For smoother low-end with a slightly reduced attack, slip the included neoprene disc inside, allowing for two distinct sound options. A pedal (not included) attaches via an I.S.S. clamp to the djembe's stand mounting plate. Includes two legs with mounting hardware, pedal bracket, head cover and neoprene muffler.

# FOLKLORIC

TRADITIONAL LOOK, MODERN INNOVATION



Tumbador 12.5" PCW-125FC	Qunito 11" PCW-110FC	Segundo 11.75" PCW-117FC	Folkloric Elite Bongos 7" & 8.5" PBW-300FC
-----------------------------	-------------------------	-----------------------------	-----------------------------------------------

#526 CRIMSON SUNRISE



Itolele PB-A60	Oconcolo PB-A50	Iya PBA-70	Bamboo Clave PCL-10FCB	Wood Clave PCL-20FCW
-------------------	--------------------	---------------	---------------------------	-------------------------

**FOLKLORIC ELITE CONGAS** Pearl's Folkloric line of congas feature a traditional look with modern innovation that only Pearl can deliver. Each 28" tall Oak drum is designed for the "seated" player, but includes stand mounts for players who prefer to stand. Thicker South American-style natural skin heads make the drums warm-sounding, but a fiberglass gel coating on the interior seals the shell and add the projection and volume desired by today's players. Four Polished Steel Reinforcing Bands are inset on the shell for a smooth touch, and the traditional hoops complete these stunning Cuban instruments.

**BATAS** Pearl Percussion Bata drums are available in Crimson Sunrise, the same beautiful finish featured on our Folkloric Elite congas and bongos. Additionally, the hardware is finished in Polished Steel and matches the hardware on our other tunable hand drums. These sacred ceremonial instruments have a thicker Enu (large) head for a deep, rich tone.



Uno PSK-50FC	Caja PSK-70FC	10" Segundo Shekere PBSK-70	Fiberglass Shekere PSK-10	Shekere Holder PPS-45	Cata w/ Holder PCA-14FC	Achere PAC-10FC	Guataca PCT-10FC
-----------------	------------------	--------------------------------	------------------------------	--------------------------	----------------------------	--------------------	---------------------



Timbao PBTB-140	Tan Tan PBTA-1420	Surdo 20" PBS-2018	Surdo 18" (Shown with optional PBS30BD) PBS-1822	Surdo 22" PBS-2222	Surdo Mallet PBSM-20	Rocar PBR-80
--------------------	----------------------	-----------------------	-----------------------------------------------------	-----------------------	-------------------------	-----------------

## BRAZILIAN PERCUSSION

Pearl's line of Brazilian Percussion brings modern refinements and Pearl quality to the traditional Samba musician. Our Repinique features lightweight yet sturdy steel shells with etched heads, shoulder straps and low rims for incredible playing comfort. The lightweight wood shell Surdos allow for hours of comfortable play when worn over the shoulder with the provided strap. Available in 18"x22", 20"x18" and 22"x22" sizes (diameter x depth), Pearl's popular Surdos continue to be the industry standard. The Timbao is made from lightweight fiberglass, and is capable of the extremely high tension utilized in tradition Brazilian ensembles. The Rocar is equipped with brass and steel platinellas, and can be played as a single shaker, or separated for two-handed sonic options.



Caixa 12" PBCX-1204	Caixa 12" PBCX-1265	Cuica PBC-80SS	Repinique 10" w/ Strap PBR-10S	Repinique 12" w/ Strap PBR-12S
------------------------	------------------------	-------------------	-----------------------------------	-----------------------------------



Pandeiro 10" (5 Sets Platinellas & Goatskin Head) w/ Bag PBP-510	Pandeiro 12" (6 Sets Platinellas & Plastic Head) w/ Bag PBP-612	Pandanza w/ Agogo Bell PDZ-510	Tamborim w/ Quick Draw Mount PBT-60C
---------------------------------------------------------------------	--------------------------------------------------------------------	-----------------------------------	-----------------------------------------

# CAJONS

GET IN THE CAJON ZONE!

Cajons are the perfect introduction to the world of percussion. Affordable, easy to carry and just plain fun to play. Pearl offers a diverse collection of Cajons and a complete selection of accessories to customize your sound.



Color: Abstract Red  
Size: 19.25" T x 11.75" W x 11.75" D

**Primero Box Cajon PBC-120B**  
The body of this Primero cajon is constructed using MDF and features a Meranti faceplate. A built in bass port magnifies the massive low-end tone of the cajon while two sets of fixed snare wires provide a bright, crisp snare response.



Color: Figured Cherry  
Size: 19.25" T x 11.75" W x 11.75" D

**Primero Box Cajon PBC-121B**  
This Primero cajon features a figured Cherry faceplate that delivers enhanced bottom-end tone that is magnified by the built in bass port. Two sets of fixed snare wires provide a bright, crisp snare response.



Color: Music Town USA  
Size: 19.25" T x 11.75" W x 11.75" D

**Primero Box Cajon PBC-122B**  
The body of this cajon is constructed using MDF and features a Meranti faceplate. The built-in bass port magnifies the massive low-end tone while two sets of fixed snare wires provide a bright, crisp snare response.



Color: Tree of Life  
Size: 19.25" T x 11.75" W x 11.75" D

**Primero Box Cajon PBC-123BTR**  
This cajon is constructed using MDF and features a Meranti faceplate with a built-in bass port and two sets of fixed snare wires. The finish features a hand painted and silkscreened design that wraps around three sides and depicts the Tree of Life.



Color: The Raven  
Size: 19.25" T x 11.75" W x 11.75" D

**Primero Box Cajon PBC-123BBR**  
The Raven cajon is constructed with MDF and has a Meranti faceplate and built-in bass port and two sets of fixed snare wires. The finish is a hand painted and silkscreened design that wraps around 3 sides featuring a stylized black raven.



Color: #507 Gypsy Brown finish  
Size: 19.75" T x 12.5" W x 12.5" D

**Primero Box Cajon PBC-507**  
Get started with Primero. Constructed from Asiatic Pine with fixed snares, this model has the right pitch and price.



Color: #650 Mango Cherry Burst  
Size: 19" T x 13" W x 13.25" D

**Centigrade Cajon PCJ-650CG**  
This Fiberglass cajon features a front faceplate with 100 degrees of angle for less stress on your lower back. The molded rear bass port projects a full, rich bass tone.



Color: #511 Natural Finish  
Size: 18.75" T x 14" W x 14.5" D

**Inner Circle Multi Drum Cajon PCJ-1C645**  
Sit on top for standard cajon playing, or unlatch, remove and place drum on the closed cajon and play like a conga at a seated height. Or attach the accompanying strap and you have a shoulder-slung djembe or Timbao.

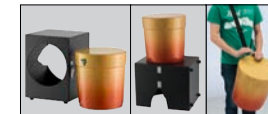

Color: Artisan Wood Grain  
Size: 18.75" T x 12.5" W x 12.5" D

**Jingle Cajon PCJ-629**  
Simply twist open the Brazilian Platinella-style jingles and a new world of sonic options open up, as you sound like two percussionists blending simultaneously.



Color: Artisan Zebra Wood  
Size: 18.75" T x 12.5" W x 12.5" D

**Boom Box Cajon PCJ-633BB**  
The Boom Box Cajon creates never-before-heard low-end frequencies from a Fiberglass cajon! Features a fixed snare system and a built-in bass port for subsonic frequencies you have to hear to believe!



Color: Black Lacquer Finish  
Size: 19" T x 12.5" W x 12.5" D

**Sambajon PCJ-SBJ**  
This Fiberglass cajon has two playing surfaces: a traditional hardwood front faceplate and a padded, cloth covered side that produces a Brazilian Surdo / "808" style bass tone. Perfect for use with any cajon pedal.



Color: #512 Sheer Black  
Size: 19" T x 11.75" W x 11.75" D

**2 Face Cajon PBC-512TF**  
This professional wood cajon with fixed snares has a 3mm thick face for a traditional low pitch and a 5mm thick face for a distinct higher pitch.



Color: Black and Natural finish  
Size: 19.75" T x 12.5" W x 12.5" D

**3D Cajon PBC-53D**  
The 3D Cajon features 3D, CNC-cut graphics on the sides of the hardwood body. Internal snares are raised to create a larger bass strike zone. Inside the faceplate is coated with clear lacquer for a crispy snare response.



Color: Artisan II finish  
Size: 18.5" T x 14" W x 14" D

**Wedge Tri-Side Cajon PCJ-3000B**  
This unique pie slice shape offers a natural seated playing position and 2 striking surfaces. Fiberglass construction with fixed snares and Artisan II finish. Ported in rear.



Color: Black and White Finish  
Size: 18.75" T x 12.5" W x 12.5" D

**Brush Beat Cajon PCJ-633BT**  
Fiberglass construction with textured surface that responds well to brushes and other effects. Ported in rear. **Black and White Finish**



Color: Bright Yellow  
Size: 13.75" T x 9.5" W x 10" D

**Fun Box Cajon PFB-300**  
Help your child develop proper playing mechanics while playing this smaller kid-friendly size cajon. Durable Fiberglass construction finished in bright yellow.

Pearl®

## CAJON ACCESSORIES

Enhance your performance by adding new, dynamic sounds.



**Wood Block w/ 3M Dual-Lock Tape & Mounting Bracket (PPS37 Not Included) PBCW-100**

**Jingle Cup Two Pack**  
Suction Cups attach to the cajon face, acoustic guitars, or other drums. **PJCP-1/6**

**Cajon Holster Nylon w/ Velcro Straps CAJH-100**

**Clave Block w/ 3M Dual-Lock Tape & Mounting Bracket (PPS37 Not Included). Play handheld or stand mounted. PBCC-100**



**3 Way Cajon Riser**  
First Lift = 21", Second Lift = 23", Third Lift = Angled Option **PBCR-1535**

**Seat Cushion w/ Thick Foam.** Adds comfort for long sessions. **PSC-BC**

## AWAKENING SERIES TONGUE DRUMS

Pearl proudly introduces the Awakening Series of 6 Tongue Drums: Three 8 note and three 9 note drums tuned to pentatonic scales.

Tongue drums derive their name from the tongue shaped areas where you strike the drum. The results are a cosmic blend of tones that are as much fun to hear as play.



**8 Note G Major #687 Blue Burst PMTD8GMF**



**8 Note A Ake Bono #688 Brown Burst PMTD8AKBF**



**8 Note A Minor #689 Green Burst PMTD8AMF**



**9 Note C Lydian #690 Orange Burst PMTD9LYDF**



**9 Note C Major #691 Crimson Burst PMTD9CPTF**



**9 Note C Ake Bono #692 Purple Burst PMTD9AKBF**



Rubber mallets included

Each drum features a 10" hardened steel shell with precise laser cut tongues for accurate and consistent tuning. Pearl Tongue drums can be played with your fingers or with a set of mallets included with each drum.

**Tongue Drum Bag PTDB-10B**



# AWAKENING SERIES

## RAINSTICKS AND NUT SHAKERS

# CONCERT PERCUSSION

## ENGINEERED FOR THE PROFESSIONAL PERCUSSIONIST

### RAINSTICKS

#### BAMBOO RAINSTICKS WITH BURNED FINISH #694 RHYTHM WATER

<p>60" Bamboo Rainstick <b>PBRSB-60</b></p> <p>48" Bamboo Rainstick <b>PBRSB-48</b></p> <p>40" Bamboo Rainstick <b>PBRSB-40</b></p> <p>32" Bamboo Rainstick <b>PBRSB-32</b></p> <p>24" Bamboo Rainstick <b>PBRSB-24</b></p> <p>16" Bamboo Rainstick <b>PBRSB-16</b></p>		<p>Pearl's natural Bamboo Rainsticks are 2.5" in diameter and feature an internal spiral maze of tines that a cascade of lava pebbles flow over to create the soothing sound of falling rain.</p>
-------------------------------------------------------------------------------------------------------------------------------------------------------------------------------------------------------------------------------------------------------------------------------------------------	--	---------------------------------------------------------------------------------------------------------------------------------------------------------------------------------------------------

Pearl has expanded its line of shakers to include six Bamboo rainsticks ranging in size from 16" to 60" and available in two unique finishes.

#### BAMBOO RAINSTICKS WITH PAINTED FINISH #693 HIDDEN SPIRIT

- 16" Bamboo Rainstick **PBRSP-16**
- 24" Bamboo Rainstick **PBRSP-24**
- 32" Bamboo Rainstick **PBRSP-32**
- 40" Bamboo Rainstick **PBRSP-40**
- 48" Bamboo Rainstick **PBRSP-48**
- 60" Bamboo Rainstick **PBRSP-60**

### NUT SHAKERS

The Awakening Series has been expanded to include a series of natural nut shakers that provide earthy tones that complement the series. Kenari, Bendo, and Pangli nuts range in size from small, medium, and large and each size possesses unique sound properties. From the recording studio to the yoga studio Pearl's Awakening Series has an instrument and sound that will inspire you.

*NOTE: Items pictured are not to scale*

<p>Pangi Nut Shaker w/ Rope Handle <b>PBGRH14</b></p>	<p>Pangi Nut Shaker w/ Bamboo Handle <b>PBPGBH12</b></p>	<p>Bendo Nut Shaker w/ Rope Handle <b>PBBDSCRH</b></p>
<p>Kenari Nut Bracelet Shaker <b>PBGLKEN</b></p>	<p>26 Kenari Nut Wind Chime *Clamp not included <b>PBKENCH01</b></p>	<p>Kenari Nut Shaker 7" <b>PBSHKENL</b></p>

Pearl is proud to offer Concert Percussion instruments that are attractively priced for school ensembles, yet engineered with the professional percussionist in mind. The symphonic tambourine is a perfect example. Its 17 pairs of specially aged, stamped brass jingles provide a dry, yet bright tone that brings added color to any musical situation. Its 10" headed wood frame allows the player to effortlessly perform all tambourine techniques, and the tambourine's plush carrying case is included. The rattler is another vital component to any concert percussionists' equipment, and Pearl's is built with an extended handle for a comfortable grip and ease of playing. Holders for the rattler and castanets are also available.



<p>Castanets (Long Handle) <b>PCN-20</b></p>	<p>Castanets <b>PCN-20S</b></p>	<p>Castanets Holder <b>PCN-20H</b></p>	<p>Slap Stick <b>PSS-100</b></p>	<p>(High) <b>PCWB-100A</b></p>	<p>(Medium) <b>PCWB-200A</b></p>	<p>(Low) <b>PCWB-300A</b></p>	<p>Mounting Bracket incl.</p>
--------------------------------------------------	-------------------------------------	--------------------------------------------	--------------------------------------	------------------------------------	--------------------------------------	-----------------------------------	-----------------------------------

<b>ELITE TRIANGLES</b>				<p>Rattler Mounting Clamp <b>PRT-10C</b></p>			
<p>Stix-Free Triangle Holder w/ 8" Triangle <b>PPS-12T</b></p>	<p>10" <b>PET-100</b></p>	<p>8" <b>PET-80</b></p>	<p>6" <b>PET-60</b></p>	<p>Triangle Beater <b>PETB-30</b></p>	<p>Triangle Clip <b>PTC-10</b></p>	<p>Temple Blocks <b>PCWTB-05</b></p>	<p>Rattler <b>PRT-10</b></p>

<p>Elite Concert Tambourine <b>PETM-20</b></p>	<p>Symphonic Tambourine <b>PETM-1017</b></p>	<p>14" Frame Drum <b>PFR-14C</b></p>	<p>Frame Drums Set of 6 · Sizes: 8", 10", 12", 14", 16", 18" <b>PFR-0818C</b></p>
----------------------------------------------------	--------------------------------------------------	------------------------------------------	---------------------------------------------------------------------------------------

**ORCHESTRAL TAMBOURINES**

The Pearl Orchestral Series Professional Tambourines provide performers a new voice and sound for any performing situation. These 5 instruments feature uniquely sourced and hand-hammered jingles combinations of German Silver, Phosphor Bronze, Beryllium Copper, and Yellow Brass that give a full spectrum of color and projection options to players. The 10" shell is a well-balanced and lightweight 2-ply Mahogany design with contoured hand-hold areas for comfortable performance and warm tone. The natural finish goatskin head provides a full responsive sound and traditional look without sacrificing durability. *Includes bag.*

<p>Mix Copper And Brass <b>PETM-1018CR</b></p>	<p>Mix Copper and Bronze <b>PETM-1018CB</b></p>	<p>Mix German Silver and Copper <b>PETM-1018GC</b></p>	<p>Beryllium Copper <b>PETM-1018CP</b></p>	<p>German Silver <b>PETM-1018GS</b></p>
----------------------------------------------------	-----------------------------------------------------	------------------------------------------------------------	------------------------------------------------	---------------------------------------------

# HAND PERCUSSION

## A WORLD OF HAND PERCUSSION



Blocks, bells, shakers and more, choose from a complete selection of hand percussion instruments to add color and impact to your music.



Natural Gourd Guiro  
**PNG-20**

Two scraping surfaces: thin grooves on one side for a lighter sound and thicker cut channels on the other side for a beefier sound. The interior is coated with fiberglass gel coat to add projection and volume.



Metal Guiro  
**PMG-20**

Perfect for Merengue rhythms, or just a different metallic sound texture, Pearl's Metal Guiro will become an essential ingredient in your "toy" bag. Scraper included.



Fiberglass Guiro  
**PFG-20**

Pearl's Fiber Guiro is light-weight and provides optimal projection due to its fiberglass construction. With the included striker and two different playing surfaces you have a world of sonic possibilities in your hand.



Guiro Holder  
**PGH-20**

This innovative design will hold virtually any size guiro secure for one handed playing. Easily mountable off the lug of your conga or any 3/8" post, Pearl's Guiro Holder uses a track system to lock the guiro in place. Included is a 3/8" "Z" rod so you can also mount your favorite accessory as well.



Beaded Maracas  
**PFM-20**

The Beaded Maracas feature Shekere-style beads which offer an excellent sound with greater control, and foam handles for enhanced comfort.



Maracabasa  
**PFM-50**

The Maracabasa is two great instruments in one, combining the functionality of a maraca and a cabasa in one handheld instrument. Featuring a ribbed fiberglass body wrapped in shekere-style beads.



Basket Ganza 9" X 4"  
**PGA-20**

The Pearl basket ganza is a 9"x4" woven tube containing wooden sticks instead of conventional shot. The wood sticks produce an airy percussion sound.



Shakelets  
**PWR-40**

This innovative percussion item feature exclusive "Ganzinellas", Brazilian-style platinellas combined with ganza shakers that are worn on the wrists to produce a shaker sound when playing.



Spirit Chimes w/  
Holder and Mallet  
**PSC30-BR**

Spirit Chimes have many applications in school bands, percussion ensembles and music programs. They are also perfect for meditation and yoga studios.



36 Anodized Aluminum Chimes  
w/ Case, Holder, And Striker  
**PWCH-3620A**

Satin black frame with polished bars  
Self-dampening parallel swinging chimes



32 Gold Anodized Aluminum Chimes  
w/ Case, Holder, and Striker  
**PWCH-3220G**

32 Gold anodized aluminum chimes  
Self-dampening parallel swinging chimes



32 Bar Aluminum Windchimes  
w/ Case, Holder, and Striker  
**PWCH-3220A**

32 Anodized Aluminum Chimes  
Self-dampening parallel swinging chimes



Foldable 36 Anodized  
Aluminum Chimes  
**PWCHF-3620AF**

Individually strung, goes from 19.25" to 9.75"  
Self-dampening parallel swinging chimes



9" Primero Rock Tambourine  
w/ Millennium Jingles  
**PTM-09BK**

The Primero Rock Tambourine features 6 double sets of Millennium Chrome Jingles in a matte black oval frame.



Headless Wood Tambourines  
**PTH-10B (Brass)**  
**PTH-10S (Steel)**

Brass is an alloy of copper and zinc and the jingles provide a bright mid-range tone.



Tambourine w/ Brass Jingles  
**PTM-10GH**

Stainless Steel jingles produce a higher tone with extra top end and sustain.



Steel Jingle Tambourine  
w/ Stainless Steel Jingles  
**PTM-10SH**

Features an inverted handle that shifts the balance point of the tambourine for improved control. Six double rows of Brass jingles create a warm metallic sound.

Features an inverted handle that shifts the balance point of the tambourine for improved control. Six double rows of Steel jingles create a bright metallic sound.



Hi-Hat Jingle Ring  
**PJH-10SH**

The Hi-Hat Jingle Ring has 20 sets of Stainless Steel tambourine style jingles that will accentuate your Hi-Hat sound with every opening and closing of your cymbals.



Ultra Grip Volume Adjustable Tambourine  
**PTM-50BHR (Brass)**  
**PTM-50SHR (Steel)**

The jingle control discs can be moved to the outside to allow the jingles to ring freely. As the jingle control discs are tightened the more restricted the jingle.



Catling Cabasa  
**CBS-100**

Brass is an alloy of copper and zinc and the jingles provide a bright mid-range tone. Steel jingles have a higher tone with extra top end and sustain.



Simply grab the precision handle and fire away to play any pattern you wish, or keep spinning it for an infinite "sizzle" that is not possible with standard Cabasas.



ASH TONE BLOCKS



Tang-Tang  
**PTG-20**

A high and low pair of unique shakers that incorporate a Caxixi-Style Plate and Wooden "Clacker."



(High) **PAB-20** (Medium) **PAB-50** (Low) **PAB-100**

Pearl's Ash Tone Blocks are constructed using Ashwood because it is extremely hard and durable. The Ash Tone Blocks are pitched in "thirds" and each block includes a mounting bracket that accepts a 3/8" post.



CLAVE BLOCKS

(High) **PBL-10** (Medium) **PBL-20** (Low) **PBL-30** Anarchy Block **PB-100**

Pearl's clave blocks are injection molded so they're virtually indestructible, and the solid color will never chip, fade, or peel. Our exclusive CDV (Chamber Density Variation) Technology process allows all three clave blocks to be the same dimensions but still differ in pitch.

Produces a low piercing pitch that will cut through even the heaviest metal rhythm section.



21" Field  
Percussion Shaker  
**PGA-60FP**

Hexagonal body and internal chamber for a truly massive sound.



Wood Hex Ganzas  
**PGA-30W (Short) PGA-32W (Long)**

The wood Hex Ganzas are made from Shorea wood and maintain the same strong projection as their aluminum brothers, but deliver a warmer less metallic tone.



Hex Ganzas  
**PGA-30 (Short) PGA-32 (Long)**

The Pearl aluminum Hex Ganzas give more sound control than round shakers and produce a lush shake sound due to their hexagonal shape.



Triple Shaker  
**PGA-40**

This 6" long, rectangular aluminum shaker provides three unique sounds: shake, click, and swish.



Groove Shaker  
**PGA-50SF** Egg Carton  
**PEC-1**

Can be played as a traditional shaker or while holding a drumstick.

Three egg shakers in a clear tube that can be played separately or as a complete unit.

# STANDS

PRO TOOLS FOR EVERY GIG



## CONGA STANDS



Pro Conga Stand  
**PC-3000**

Quick Release Double  
Conga Stand w/ Bag  
**PC-3000TW**

Ultra Lite  
Conga Stand  
**PC-2500**

## PERCUSSION STANDS & BRACKETS

The PC-3000TW stand holds full size professional congas as securely as most stands double its weight and mass. The PC-300W is scaled down to support our lighter Primero Conga lineup. Both stands setup in seconds because there are no wingnuts needed to mount your congas. The PC-2500 Ultralite Conga stand, is lightweight yet sturdy and stable. Index markings on all adjustable parts make for consistent lightning fast setups.



All-Fit  
Conga Stand  
**PC-900**

Quick Release  
Double Conga Stand  
**PC-300W**

Primero Twin  
Conga Stand  
**PC-200**

Primero Basket Conga Stands  
**PC-100P (10") PC-110P (11")**

## BONGO STANDS



Pro All Fit Bongo Stand with  
Spring Loaded Strap Hinge  
**PB-3000**

Bongo Stand for  
Seated and Concert Players  
**PB-3000S**

All-Fit Tilting  
Bongo Stand  
**PB-900LW**

Lightweight  
Bongo Stand  
**PB-700**

Bongo Attachment  
for PC-200  
**PB-700BHS**

## DJEMBE STANDS



Pro Djembe Stand  
**PD-3000**

All-Fit Djembe Stand  
**PC-800S**

## CAJON STANDS



Cajon Stand  
**PC-J70STD**

## TRAP TABLES

Our popular PTT-1824 Trap Table can be easily converted into a two-level folding rack without drilling or modifications by simply adding the PTR-1824 Add-On Rack. The PTR-1824 installs in seconds using clamps and folds flush with the table for easy pack-up. A unique clamping system allows the included (4) straight and (4) angled 3/8" knurled posts to clamp anywhere onto horizontal or vertical areas of the rack. Also included is a retractable three-legged stabilizer bar for optimum stability. The easy-to-attach PTR-UNV Universal Trap Table Rack mounts on virtually any trap table and features six 3/8" rods and receptors for various percussion mounting possibilities.



Trap Table Single  
Braced (18" x 24")  
**PTT-1824**

Trap Table Double  
Braced (18" x 24")  
**PTT-1824W**

Aluminum Trap  
Table (15" x 24") w/ Stand  
**PTT-1524MPW**

Trap Table  
(12" x 12")  
**PTT-212**

(Table & Stand Sold  
Separately From Rack)

Universal Trap Table Rack  
**PTR-UNV**

Trap Table Rack  
**PTR-1824**

3/8"  
Straight Post  
**PTR-1824RC1**

3/8"  
Angled Post  
**PTR-1824RC2**

Post  
Attachment  
**PTR-1824RC6**

(FOR PTT-1824, PTT-1212)

Trap Table Single  
Post Adapter  
**PTR-1824RC3**

## PERCUSSION CASES

Features include: ergonomic carrying straps, rubber protective bottoms, top-mounted carrying handles, tuning wrench pouches, & heavy duty double zippers.



Conga Bag -  
Quinto  
**PSC-110CGW**

Conga Bag -  
Conga  
**PSC-117CGW**

Conga Bag -  
Tumba  
**PSC-125CGW**

12" Djembe  
Bag  
**PBJ-CXL**

14" Djembe  
Bag  
**PBJ-CXXL**

Bongo  
Bag  
**PSC-BB**

12.5"  
Conga Bag  
**PSC-125CG**

11.75"  
Conga Bag  
**PSC-117CG**

11"  
Conga Bag  
**PSC-110CG**

14"  
Djembe Bag  
**PSC-140DJ**

12.5"  
Djembe Bag  
**PSC-125DJ**

## HOLDER & ACCESSORIES



Angled Post  
Adapter  
**PPS-37**

Lug Mount  
Accessory Holder  
**PPS-40**

Universal  
Guiro Holder  
**PGH-20**

Foot Pedal  
Bracket  
**PPS-20**

Cowbell  
Stacker  
**PCS-10**

Stix-Free  
**PPS-10 & PPS-11**

Percussion Toy Box  
(Accessories Not Included)  
**PTYB-1212**

## COWBELL HOLDERS



**CA-130**

**75H**

**75X**

**PPS-81**

**PPS-82**

# REPLACEMENT PARTS

Pearl offers a tremendous number of parts for our drums and hardware. The parts represented on these pages are some of the most commonly requested items.

For a more complete parts selection, please see our spare parts catalogs located under the Support tab at [www.pearldrums.com](http://www.pearldrums.com)

## MASKING COVERS & MOUNTING BRACKET

The GK90 and BBC1 cover the holes of BT3 and BB3 brackets that have been removed.



- BBC-1** for BB3, w/Casket, Screws and Nuts
- GK-90** for BT3, inside/outside plates w/Bolts
- BT-3** Tom Tom Bracket

## BASS DRUM HOOP PROTECTORS



- HPP-2** Metal Hoop Protector for Wood BD Hoops
- NP-01** Hoop Protector for Metal BD Hoops
- NP-347/2** Non-Slip Hoop Protector for Wood BD Hoops (pair)

## P2050 SERIES CAMS



- P2050 SERIES CAMS**
- CAM-PL** Eliminator Purple Cam, Aggressive Action
  - CAM-YL** Eliminator Yellow Cam, Inverse Action
  - CAMT-BK** Eliminator Translucent Black Cam, Linear Action
  - CAMT-WT** Eliminator Translucent White Cam, Oversized Linear Action
  - CAMT-BL** Eliminator Translucent Blue Cam, Progressive Action
  - CAMT-RD** Eliminator Translucent Red Cam, Radical Action

## FLOOR TOM LEGS & BRACKETS



- FTL-07C/3** Floor Tom Legs (3 Legs)
- LG-40L/3** Long Floor Tom Legs (3 Legs)
- LB-40** Leg Bracket for Masters Series

## HI-HAT CLUTCHES & PARTS

**RAPID LOCK HI-HAT CLUTCHES**  
Hi-Hat set-up and tear-down is a breeze with Rapid-Lock's Patented\* two-point quick release locking system. \*U.S. Patent #9355625

- HCL-205DQR** Rapid Lock Quick Release Hi-Hat Drop Clutch w/ Locking Nut
- HCL-205QR** Rapid Lock Quick Release Super Grip Hi-Hat Clutch w/ Locking Nut
- HCL-105QR** Rapid Lock Quick Release Hi-Hat Clutch w/ Locking Nut
- HCL-79** Hi-Hat Clutch Complete
- HHC-90** Plastic Cup w/ Tilter



## CHAINS & BELTS



- CCA-5** Chain Assy Complete for Eliminator Pedals
- BCA-250** Belt Assy Complete for P2050 Eliminator Pedals

## SPRING



- SP-64F** Spring for P-930 / P-932

## BEATERS & BEATER WEIGHTS



- D-B100** Duo-Beater Felt/Plastic
- B-250QB** Control Core Quad Beater
- BEATER WEIGHTS**
- BW-100** Beater Weight, 3 Weights in One (U.S. Patent #7122730)

## MASTERCAST HOOPS

MasterCast are the finest die cast hoops available and feature the perfect blend of thickness and mass to improve the depth, clarity, and focus of toms and snare drums.



Model #	Diameter	# of Tension
DC-0805	8"	5
DC-1006	10"	6
DC-1206	12"	6
DC-1306	13"	6
DC-1408	14"	8
DC-1408S	14"	8 Snare Side
DC-1410	14"	10
DC-1410S	14"	10 Snare Side
DC-1410SG	14"	10 Snare Side w/Guard
DC-1508	15"	8
DC-1608	16"	8
DC-1808	18"	8

## SuperHoop II & FATTONE HOOPS

SuperHoop II hoops are precision formed from heavy-duty 2.3mm steel, triple-flanged and engraved with the SuperHoop II logo. FatTone hoops are low mass 1.6mm hoops with hemmed and welded edges for strength and rigidity.



Super Hoop Model #	FatTone Hoop Model #	Diameter	# of Tension
SH-0604	NA	6"	4
SH-0805	FH0805	8"	5
SH-1006	FH1006	10"	6
SH-1006S	NA	10"	6 Snare Side
SH-1206	FH1206	12"	6
SH-1208	NA	12"	8
SH-1208S	NA	12"	8 Snare Side
SH-1306	FH1306	13"	6
SH-1308	FH1308	13"	8
SH-1308S	FH1308S	13"	8 Snare Side
SH-1408	FH1408	14"	8
SH-1408S	NA	14"	8
SH-1410B	FH1410	14"	10
SH-1410S	FH1410S	14"	10 Snare Side
SH-1410SG	NA	14"	10 Snare Side w/Guard
SH-1508	FH1508	15"	8
SH-1510S	NA	15"	10
SH-1510B	NA	15"	10
SH-1608	FH1608	16"	8
SH-1808	FH1808	18"	8

## STEEL HOOPS

Steel Hoop Model #	Diameter	# of Tension
RH-0804	8"	4
RH-1006	10"	6
RH-1206	12"	6
RH-1306	13"	6
RH-1408	14"	8
RH-1408S	14"	8 Snare side
RH-1608	16"	8
RH-1808	18"	8



## BASS DRUM PEDAL TRAINING PAD

**BD-10**  
The BD-10 bass pad is perfect for practicing at home or on the road. The wide pad accommodates double pedals and is specially formulated for extremely low noise and a realistic feel. The universal-fit "hoop" accepts all brands of pedals and adjusts to compensate for different floor surfaces. The BD10 folds for compact transport.



## QUICK RELEASE WINGLOC

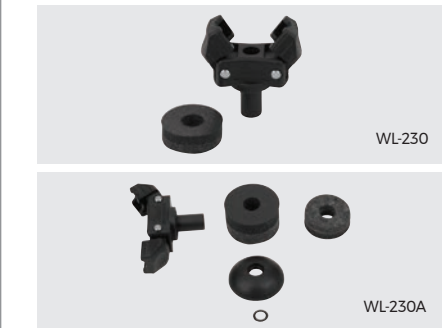

- WL-230** Quick Release WingLoc
- WL-230A** Quick Release WingLoc Complete

## SEAT CUPS AND FELTS



- RC-20** Reversible Seat Cup, w/ O-Ring
- PL-011** Cymbal Seat Cup
- FLW-001/2** Cymbal Felt Washer (2 Pieces)
- FLW-003** Hi-Hat Cup Felt Washer

## STOP LOCK



- ZD-081A** Stop Lock Complete

## DRUM KEYS



- KGT-100** Cyro Tune Key w/ Quick Release
- K-030** Hi-Tension Tuning Key
- K-080** Tuning Key
- K-180** Spin-Tight Key

## AIR SUSPENSION FEET



- R-40/3** Air Suspension Rubber Feet (3 Each)
- R-5/3** Rubber Tip



MASTERS MAPLE GUM SHOWN WITH MASTERCRAFT HOOPS



MASTERS MAPLE COMPLETE SHOWN WITH SuperHoop II HOOPS

## LUGS

- CL-05** Lug for 3" Piccolo Snare
- CL-50** Lug for 5" Deep Snare
- CL-55** Lug for 5.5" Deep Snare
- CL-65** Lug for 6.5" Deep Snare
- CL-100** Lug for 7" Deep Snare



# REPLACEMENT PARTS

Pearl offers a tremendous number of parts for our drums and hardware. The parts represented on these pages are some of the most commonly requested items.

For a more complete parts selection, please see our spare parts catalogs located under the Support tab at [www.pearldrums.com](http://www.pearldrums.com)

## OPTI-LOC



OPL-1216

Opti-Loc suspension tom holders provide exceptional stability while greatly improving resonance and sustain. (For EXX / EXL Export / DMP)

- OPL-0608/C** Opti-Loc for EXX and DMP 6"-8" Diameter
- OPL-1216/C** Opti-Loc for EXX and DMP 12"-16" Diameter

## JUNGLE GIG



JG-16

**JG-16** - Pearl's Jungle Gig allows the conversion of a 16" Floor Tom to a Bass drum.

## OPTIMOUNT

Our OptiMount Suspension System attaches to the tom's tension rods and floats on rubber cushions, providing the ultimate in stability while allowing the drum to resonate fully without restriction. With OptiMount, the mounting hardware is completely removed from the drum shell, providing a drastic improvement in resonance and sustain.



OPTA-0708 OPTA-0910 OPTA-1112



OPT-0708 OPT-0910 OPT-1112



OPT-1314 OPT-1516

- OPTA-0708/C** for drums 7"-8" deep, 6"-16" diameter, Light Weight Aluminum
- OPTA-0910/C** for drums 9"-10" deep, 6"-16" diameter, Light Weight Aluminum
- OPTA-1112/C** for drums 11"-12" deep, 6"-16" diameter, Light Weight Aluminum
- OPTA-1314/C** for drums 13"-14" deep, 6"-16" diameter, Light Weight Aluminum
- OPTA-1516/C** for drums 15"-16" deep, 6"-16" diameter, Light Weight Aluminum

- OPT-0708** for drums 7"-8" deep, 8"-16" diameter, UltraGrip Wingnut
- OPT-0910** for drums 9"-10" deep, 8"-16" diameter, UltraGrip Wingnut
- OPT-1112** for drums 11"-12" deep, 8"-16" diameter, UltraGrip Wingnut
- OPT-1314** for drums 13"-14" deep, 8"-16" diameter, UltraGrip Wingnut
- OPT-1516** for drums 15"-16" deep, 8"-16" diameter, UltraGrip Wingnut

## MUFFLERS

External clamp-on muffler for snare drums and toms. By adjusting the pressure and position of the felt pad, excessive overtones can be precisely controlled or eliminated.



OM-1

- OM-1** Clamp-on Muffler, Snare Drum & Toms

## MUFFLE HEADS

Model #	Size	Model #	Size
<b>MFH-08</b>	8"	<b>MFH1-4</b>	14"
<b>MFH-10</b>	10"	<b>MFH-16</b>	16"
<b>MFH-12</b>	12"	<b>MFH-20B</b>	20"
<b>MFH-13</b>	13"	<b>MFH-22B</b>	22"

## BASS DRUM MUFFLER



BDM-F

BDM-M

- BDM-F** Bass Drum Muffler (Full Size)
- BDM-M** Bass Drum Muffler (Mini Size)

## STRAINERS



SR-017

- SR-014N** Standard Snare Strainer
- SR-017** Snare Strainer Complete
- SR-018** Snare Strainer Complete

## TENSION ROD LOCKNUTS



- TNK-10N/10** Tension Keeper (10/pkg)
- TL-20/10** Tension Rod Lock Nuts (10/pkg)

## TENSION ROD WASHERS



- NLW-12B/12** Nylon Washers (12) Black
- MTW-12/12** Metal Washers (12)



## ULTRA-SOUND SNARES

Pearl's Ultra-Sound snares feature patented Graduated Tension wires for extended dynamic range from ultra soft to ultra loud. Ultra-thin, low mass end plates assure ultra quick response. The end plates feature three mounting options: tunnels or holes for cord mounting and slots for straps. *U.S. Patent #7202405*



- SN-1320C** 20 strands for 13", C-type, w/ straps & cords
- SN-1320D** 20 strands for 13", D-type, w/ straps & cords
- SN-1320I** 20 strands for 13", I-type, w/ straps & cords
- SN-1420C** 20 strands for 14", C-type, w/ straps & cords
- SN-1420D** 20 strands for 14", D-type, w/ straps & cords
- SN-1420I** 20 strands for 14", I-type, w/ straps & cords



- SN-1442C** 42 strands for 14", C-type, w/ straps & cords
- SN-1442D** 42 strands for 14", D-type, w/ straps & cords
- SN-1442I** 42 strands for 14", I-type, w/ straps & cords

## REPLACEMENT SNARES

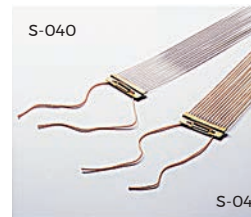

- S-022N** 20 Strand for 14" w/ Cords
- S-022NU** 20 Strand for 14" w/ Cords, Uncoated
- S-022** 20 Strand for 14" w/ Straps
- S-025** 20 Strand for 14" long, w/ Straps
- S-029N** 20 Strand for 13" w/ Cords
- S-030N** 24 Strand for 14" w/ Cords
- S-031N** 20 Strand for 12" w/ Cords
- S-032N** 12 Strand for 10" w/ Cords
- S-033N** 12 Strand for 12" w/ Cords
- S-040** 15 Strand for 14" w/ Cords, Steel Cable, Thinner Gauge
- S-041** 15 Strand for 14" w/ Cords, Bronze Cable, Thicker Gauge
- SPS-18/6** Plastic Strap (6/pkg)
- SNC-500R/4** Snare Cord (4/pkg)

## SPIN-TIGHT™ TENSION RODS

Specially-designed stainless steel tension rods that lock to maintain tension settings. Starter pack includes 4 Spin-Tight Tension rods with K-180 Drum Key.



- SPT-5047** W7/32 x 47mm (1)
- SPT-4SPK** W7/32 x 47mm (4) w/ K180 Drum Key
- SPT-6PK** W7/32 x 47mm (6)

## STAINLESS STEEL TENSION RODS

Pearl's Stainless Steel Tension Rods are machined, not forged, from a single piece of stainless steel to the most exacting tolerances in the industry. They feature super-smooth, precise tensioning, with absolutely no play. Each non-plated stainless steel tension rod is matched with a precision-machined brass swivel nut for ultra-precise performance.

- SST-5028/6** W7/32 x 28mm (6)
- SST-5035/6** W7/32 x 35mm (6)
- SST-5038/6** W7/32 x 38mm (6)
- SST-5042/6** W7/32 x 42mm (6)
- SST-5047/6** W7/32 x 47mm (6)
- SST-5052/6** W7/32 x 52mm (6)

## TENSION RODS

- T-055/6** W7/32 x 28mm (6) for 3" Deep Snare
- T-060/6** W7/32 x 35mm (6) for Free Floaters before 2002
- T-061/6** W7/32 x 42mm (6)
- T-061L/6** W7/32 x 47mm (6) for 6.5" Deep Snare
- T-062/6** W7/32 x 52mm (6) for 5.5" Deep Snare
- T-065** M6 x 90mm (Bass Drum)
- T-066** M6 x 115mm (Bass Drum)
- TR-5052** W7/32 x 52mm (DMP, EXL, EXX, MDT Snare)
- TR-5047** W7/32 x 47mm (DMP, EXL, EXX, MDT Toms)
- TR-5100** W7/32 x 100mm (Bass Drum)



 <b>A-YEON</b> INDEPENDENT	 <b>A. SIVAMANI</b> INDEPENDENT	 <b>AARON SMITH</b> INDEPENDENT	 <b>ADRIAN BENT</b> DRAKE	 <b>ALEX HOLZWARTH</b> RHAPSODY REUNION
 <b>BRIAN FRASIER-MOORE</b> JUSTIN TIMBERLAKE	 <b>ALEXANDRE APOSAN</b> INDEPENDENT	 <b>ALVIN FORD</b> ED O'BRIEN / TROMBONE SHORTY	 <b>ANDRE MATTOS</b> TRAZENDO A ARCA	 <b>ANTHONY BEVERLY</b> AL MCKAY ALLSTARS
 <b>AREJAY HALE</b> HALESTORM	 <b>ARIËN VAN WEESENBEEK</b> EPICA	 <b>AUGUSTO SILVA</b> AUGUSTO SILVA & FREVO NOVO	 <b>CASEY COOPER</b> COOP3RDUMM3R	 <b>BAARD KOLSTAD</b> LEPROUS
 <b>BARRY KERCH</b> SHINEDOWN	 <b>BEN GORDON</b> PARKWAY DRIVE	 <b>ERIC SINGER</b> KISS	 <b>BEN JOHNSTON</b> BIFFY CLYRO	 <b>DENNIS CHAMBERS</b> DRUMMING LEGEND
 <b>CALVIN RODGERS</b> INDEPENDENT	 <b>BRANDON COMBS</b> LEÓN BRIDGES	 <b>BRANDON PERTZBORN</b> MARILYN MANSON	 <b>BRUNO VALVERDE</b> ANGRA	 <b>CALEB GILBREATH</b> BRETT ELDRIDGE
 <b>GENE HOGLAN</b> TESTAMENT / DETHKLOK	 <b>CHAD CROMWELL</b> JOE WALSH / NEIL YOUNG	 <b>CHAD SEXTON</b> 311	 <b>DANIEL ERLANDSSON</b> ARCH ENEMY	 <b>HORACIO HERNANDEZ</b> LATIN LEGEND
 <b>CHARLIE ENGEN</b> FIVE FINGER DEATH PUNCH	 <b>CHRIS RALLES</b> PAT BENATAR	 <b>DANI LOBLE</b> HELLOWEEN	 <b>CODY DICKINSON</b> NORTH MISSISSIPPI ALLSTARS	

 <b>DAN KERBY</b> BLISS N ESO / 28 DAYS BEHIND CRIMSON EYES	 <b>DAN PRESLAND</b> NE OBLIVISCARIS	 <b>DANA LAMARCA</b> MAGGIE ROGERS	 <b>FLO MOUNIER</b> CRYPTOPSY
 <b>DANIEL FURNARI</b> POLARIS	 <b>IAN PAICE</b> DEEP PURPLE	 <b>DARSHAN DOSHI</b> INDEPENDENT	 <b>DENA TAURIELLO</b> BROADWAY
 <b>DESMOND DAVIS</b> HUNTER HAYES	 <b>DUSTIN STEINKE</b> SIXX.A.M.	 <b>ELISE TROUW</b> INDEPENDENT	 <b>JASON BITTNER</b> OVERKILL
 <b>GARY HUSBAND</b> INDEPENDENT	 <b>GABOR DORNYEI</b> THUNDERDUO / INDEPENDENT	 <b>GE WEI BIN</b> INDEPENDENT	 <b>GENE JACKSON</b> INDEPENDENT
 <b>GINO BANKS</b> INDEPENDENT	 <b>JASON BOWLD</b> BULLET FOR MY VALENTINE	 <b>GRANT COLLINS</b> INDEPENDENT	 <b>JOEY JORDISON</b> INDEPENDENT
 <b>INFERNO</b> BEHEMOTH	 <b>GEORGE KOLLIAS</b> NILE	 <b>ISAAC TEEL</b> TAUK	 <b>JAI ROW KAVI</b> INDEPENDENT
 <b>JAMIE PERKINS</b> THE PRETTY RECKLESS	 <b>JAN RECHBERGER</b> AMORPHIS	 <b>JASKA</b> CHILDREN OF BODOM	 <b>JASON HARTLESS</b> TED NUGENT
 <b>JEFF MARINO</b> DARIUS RUCKER	 <b>JERROD SULLIVAN</b> THE 4 KORNERS	 <b>JESSE WANG</b> INDEPENDENT	 <b>JOEY KRAMER</b> AEROSMITH
 <b>JESSIE CARABALLO</b> MARC ANTHONY			

# PEARL ARTISTS

VIEW ALL THE PEARL ARTISTS AT: [WWW.PEARLDRUM.COM/ARTIST](http://WWW.PEARLDRUM.COM/ARTIST)

 <b>JOE LONGOBARDI</b> THE AMITY AFFLICTION	 <b>JOCKE WALLGREN</b> AMON AMARTH	 <b>JOE TOMINO</b> MATISYAHU / DUB TRIO	 <b>JOHN LONGSTRETH</b> ORIGIN	 <b>NATE MORTON</b> THE VOICE	 <b>NOAH "WUV" BERNARDO</b> P.O.D.	 <b>OLI BEAUDOIN</b> KATAKLYSM	 <b>PARK, YOUNG JIN</b> SINAWA / BAADA / MYORI	 <b>PAUL KOEHLER</b> SIVERSTEIN DAVID	 <b>PETE WEBBER</b> HAVOK	 <b>QUINTON "Q" ROBINSON</b> INDEPENDENT
 <b>MATT MCGUIRE</b> THE CHAINSMOKERS	 <b>JOHN WICKS</b> FITZ AND THE TANTRUMS	 <b>JON LARSEN</b> VOLBEAT	 <b>JONATHAN MOVER</b> INDEPENDENT	 <b>MATT HALPERN</b> PERIPHERY	 <b>ROBBY AMEEN</b> INDEPENDENT	 <b>RAY FEAN</b> CELTIC WOMAN	 <b>ROBERT ORTIZ</b> ESCAPE THE FATE	 <b>ROD QUINN</b> GILBERT O'SULLIVAN	 <b>RYAN MORAN</b> SLIGHTLY STOOPID	 <b>JOSH BAKER</b> MARIAH CAREY
 <b>KAI HAHTO</b> NIGHTWISH	 <b>MIKE MANGINI</b> DREAM THEATER	 <b>KAN UMSUUPAN</b> POTATO	 <b>JUAN "CARLITO" MENDOZA</b> INDEPENDENT	 <b>JUNGHOOON LEE</b> INDEPENDENT	 <b>RODNEY HOWARD</b> INDEPENDENT	 <b>SHANNON FORREST</b> TOTO / SESSIONS	 <b>RUDY SANCHEZ</b> INDEPENDENT	 <b>RAY LUZIER</b> KORN / KXM	 <b>SAM LOEFFLER</b> CHEVELLE	 <b>SARA DUAN</b> INDEPENDENT
 <b>KRIS MYERS</b> UMPHREY'S MCGEE	 <b>KENWOOD DENNARD</b> INDEPENDENT	 <b>KIKO FREITAS</b> INDEPENDENT	 <b>LENNY "THE OX" REECE</b> THE LESSON GK	 <b>MORGAN ROSE</b> SEVENDUST	 <b>SEGIO MELO</b> THE VOICE BRAZIL	 <b>SUN YU DONG</b> INDEPENDENT	 <b>TARON LOCKETT</b> CORY HENRY AND THE FUNK APOSTLES	 <b>SHAUN FOIST</b> BREAKING BENJAMIN	 <b>STIX HOOPER</b> THE CRUSADERS	 <b>TAVARIUS JOHNSON</b> LALAH HATHAWAY
 <b>LESTER ESTELLE</b> KELLY CLARKSON / SESSIONS	 <b>LI HAO</b> INDEPENDENT	 <b>MICHEL "MOOSE" THOMAS</b> KILL THE LIGHTS	 <b>LIM, YONG HOON</b> INDEPENDENT	 <b>MICHAEL CARTELLONE</b> LYNYRD SKYNYRD	 <b>TOM HURST</b> INDEPENDENT	 <b>TOMMY PORTIMO</b> SONATA ARCTICA	 <b>TONY PALERMO</b> PAPA ROACH	 <b>TRACY BROUSSARD</b> BLAKE SHELTON	 <b>TREVOR ORBIN</b> DARKEST HOUR / INDEPENDENT	 <b>MARCUS FINNIE</b> MF BAND
 <b>OMAR HAKIM</b> INDEPENDENT	 <b>MARK ALFRED</b> RIVERDANCE	 <b>MARTIN "MARHUS" SKAROUPKA</b> CRADLE OF FILTH	 <b>MARVIN "SMITTY" SMITH</b> INDEPENDENT	 <b>MATT ABTS</b> GOVT MULE	 <b>TERENCE HIGGINS</b> WARREN HAYNES / ANI DI FRANCO	 <b>TODD SUCHERMAN</b> STYX	 <b>TRE STAFFORD</b> ADELITAS WAY	 <b>MELVIN BALDWIN</b> NEW EDITION / JOHNY GILL	 <b>MIGUEL LAMAS</b> INDEPENDENT	 <b>MINHYUK KANG</b> CNBLUE
 <b>MORITZ MUELLER</b> THE INTERSPHERE	 <b>MYUNGHO WANG</b> KIM KYUNGHO	 <b>MIKE WENGRN</b> DISTURBED	 <b>WILL KENNEDY</b> YELLOWJACKETS / JAZZ LEGEND	 <b>TROY WRIGHT</b> INDEPENDENT	 <b>WANG PENG</b> INDEPENDENT	 <b>WES LITTLE</b> INDEPENDENT	 <b>WILL HUNT</b> EVANESCENCE	 <b>ZHANG JIONG</b> INDEPENDENT		

## SPECIAL COVERING FINISHES

### REFERENCE / REFERENCE PURE

### MASTERS MAPLE RESERVE / MASTERS MAPLE GUM

PAGES 14 - 21



### MASTERS MAPLE COMPLETE

PAGES 22 - 23



### SESSION STUDIO SELECT

PAGES 24 - 25



### CRYSTAL BEAT

PAGES 26 - 27



### DECADE MAPLE

PAGES 28 - 29



### EXPORT LACQUER

PAGE 30



### EXPORT

PAGE 31



### MIDTOWN

PAGE 32

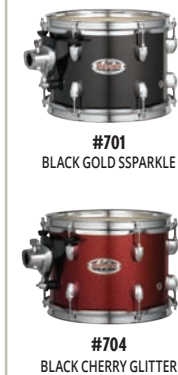

### ROADSHOW

PAGE 33





# Pearl® SPECIAL ORDER LACQUER FINISHES

**REFERENCE** SONICALLY SELECT DRUM PERFORMANCE. \_\_\_\_\_

PAGES 14 - 15

**REFERENCE PURE** UNRESTRICTED TONAL RESPONSE. \_\_\_\_\_

PAGES 16 - 17

**MASTERS MAPLE RESERVE** A CLASSIC FORMULA FOR SONIC GREATNESS. \_\_\_\_\_

PAGES 18 - 19

**MASTERS MAPLE GUM** THE EVOLUTION OF PREMIUM STUDIO TONE \_\_\_\_\_

PAGES 20 - 21



#100  
WINE RED



#102  
NATURAL MAPLE



#103  
PIANO BLACK



#109  
ARCTIC WHITE



#111  
MATTE NATURAL (MAPLE)



#124  
MATTE BLACK MIST



#128  
VINTAGE SUNBURST



#143  
TWILIGHT FADE



#151  
PLATINUM MIST



#152  
ANTIQUE GOLD



#155  
SCARLET FADE



#195  
CRYSTAL RAIN



#199  
NAVY BLUE SPARKLE



#201  
MATTE WALNUT (MAPLE)



#302  
INCA GOLD BURST



#310  
BROOKLYN BURST



#330  
IVORY PEARL



#331  
BLACK PEARL



#332  
RED PEARL



#335  
BLACK CHERRY



#342  
VINTAGE TOBACCO BURST



#343  
OLIVE BURST



#345  
SATIN AUBURN



#347  
BOMBAY GOLD SPARKLE



#353  
MATTE WHITE



#354  
SAPHIR BORDEAUX SPARKLE



#355  
ANTIQUE WALNUT



#356  
TANGERINE DREAM



#359  
TWILIGHT BURST



#376  
ULTRA BLUE FADE



#377  
SCARLET SPARKLE BURST



#393  
PURPLE CRAZE II



#830  
AUTUMN FIRE SPARKLE



#831  
MATTE OLIVE BURST



#832  
SAPPHIRE BLUE SPARKLE



#833  
EMERALD SPARKLE



#834  
GLACIER BLUE SPARKLE



#835  
AGED HONEYBURST



#839  
RED BURST TRIBAND



#842  
LIGHT AMBER



#843  
ORISIA ROSE STRIPE



#844  
SATIN ROSE GOLD

Colors shown in this catalog are for representation only and may not be exactly the same as the original colors due to the printing processes involved.

Products and specifications are subject to change without notice.

[www.pearldrums.com](http://www.pearldrums.com)



item PGC202106