

Pearl Drums 2008 **Color Line Up**
Reference **RF**



PEARL DRUMS AND PEARL PERCUSSION GENERAL CATALOG 2008

PEARL DRUMS
 AND
 PEARL PERCUSSION
 GENERAL CATALOG
 2008

PEARL DRUMS
 AND
 PEARL PERCUSSION
 GENERAL CATALOG
 2008
Pearl

For more information on these or any Pearl product, visit your local authorized Pearl Dealer.
 You can also visit us on the World Wide Web Site www.pearldrums.com

colors shown in this catalog are for representation only
 and may not be exactly the same as the original colors due to the printing processes involved.
 Products and specifications are subject to change without notice.



Masters Premium **MMP/MRP**



Vision **VMX**



Vision **VBX**



Masters Premium **BMP/BRP**

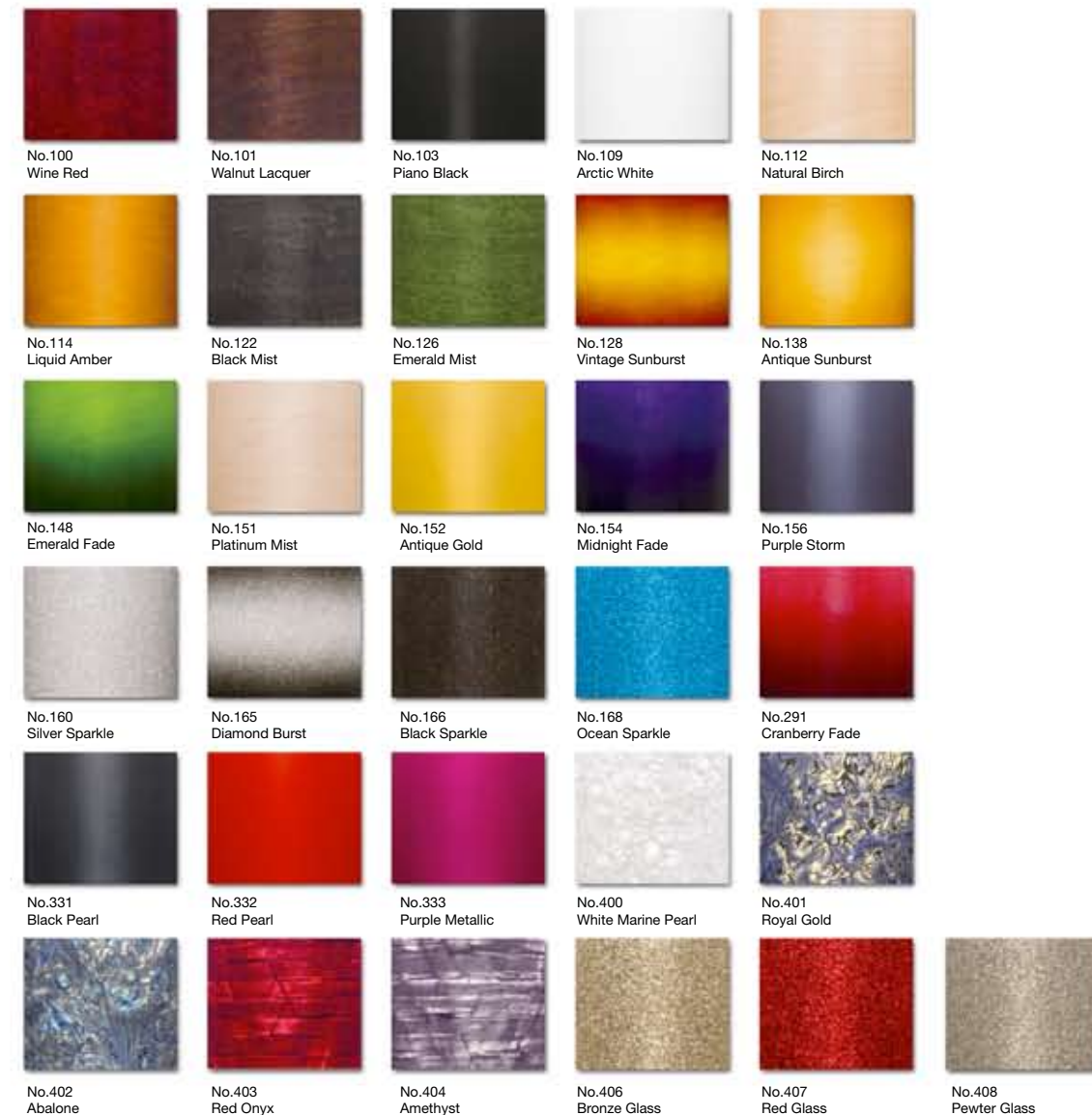

Vision **VSX**



Vision **VX**

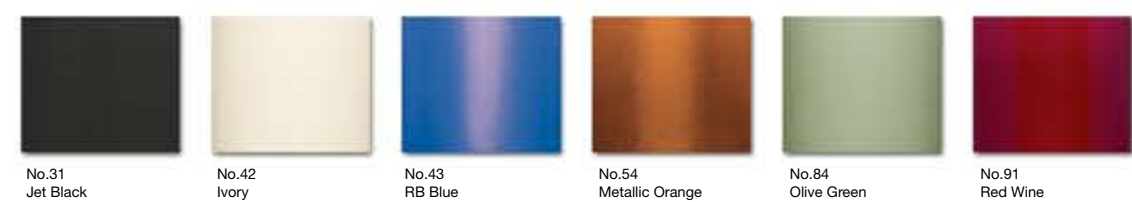

Masters **MCX**



Forum **FZ**



PEARL DRUMS
2008



Mike Mangini
Independent
U.S.A.



Shane Gaalaas
Cosmosquad, Diesel Machine
U.S.A.



Virgil Donati
Planet X, Virgil Donati Band
U.S.A.



Jessie Caraballo
Mark Anthony
U.S.A.



Steve Houghton
Independent
U.S.A.



Billy Hart
Independent
U.S.A.



Kenwood Dennard
Just Advance
U.S.A.



Ben Smith
Heart
U.S.A.



Rich Beddoe
Finger Eleven
U.S.A.



Dave DiCenso
Independent
U.S.A.



Rodney Howard
Avril Lavigne
U.S.A.



Michael Cartellone
Lynyrd Skynyrd
U.S.A.



John Humphrey
Seether
U.S.A.



Tommy Campbell
Independent
U.S.A.



Johnny Kelly
Type O Negative
U.S.A.



Craig Nunenmacher
Black Label Society
U.S.A.



Criz
Lacuna Coil
U.S.A.



Barry Kerch
Shinedown
U.S.A.



Gene Hoglan
Strapping Young Lad
U.S.A.



Brian Young
Fountains of Wayne
U.S.A.



Gene Jackson
Independent
U.S.A.



Ray Fean
Celtic Woman
Ireland



Flo Mounier
Cryptopsy
Canada



Nate Morton
ROCKSTAR, Paul Stanley
U.S.A.



Anthony Johnson
Bonnie Pink
U.S.A.



Ryan Richards
Funeral for a Friend
UK



Cody Hanson
Hinder
U.S.A.



Matt Abts
Gov't Mule
U.S.A.



Sean Rickman
Dapp Theory
U.S.A.



Steve Gillis
Independent
U.S.A.



Jack Irons
Independent
U.S.A.



Jonathan Mover
Independent
U.S.A.



Chad Gracey
Live
U.S.A.



Yonrico Scott
Derek Trucks Band
U.S.A.



Clarence Penn
Makoto Ozone
U.S.A.



Rick Gratton
Independent
Canada



Dani Löble
Helloween
Germany



Igor Cavalera
Independent
Brazil



Rudy Sanchez
Independent
Mexico



Rosa Avila
Andy Williams
Mexico



Jon Fariss
INXS
Australia



Torry Castellano
The Donnas
U.S.A.



Grant Collins
Independent
Australia



Michael Barker
The John Butler Trio
Australia



Munetaka Higuchi
Loudness
Japan



Hiro Tsunoda
Independent
Japan



Shuichi "Ponta" Murakami
Independent
Japan

A TRADITION OF EXCELLENCE

Post-war Japan was a time for reconstruction, but it was also a time for new influences, such as Jazz and American-style music education. This created a new generation of musicians who needed affordable musical instruments which, at that time, were in scarce supply. Recognizing this need, Katsumi Yanagisawa started Pearl in a small factory with less than 300 sq. ft. and 2 employees in Sumida, Tokyo on April 2, 1946.

By 1953 Pearl was producing basic drumsets, marching drums, concert drums, timpani, Latin percussion instruments, cymbals stands and accessories for the Japanese domestic market. The company had 30 employees at this time, and was enjoying rapid growth.

In 1957, Mitsuo Yanagisawa, Katsumi's son, joined the company and immediately formed an international export division to meet the growing demand from other countries, including the U.S.

In 1961, with the popularity of rock and roll and the demand for drums increasing, Pearl purchased 43,000 sq. ft. of land in Chiba and built a 15,000 sq. ft. factory to meet this demand.

Starting in 1965, under Mitsuo's leadership, Pearl implemented a long range plan to 1) increase the number and variety of product lines, including the development of new high quality products to meet the needs of top professionals around the world; 2) to assemble the highest caliber research and development staff; 3) to invest in the latest automated machinery in the Chiba factory and build a new factory in Taiwan; and 4) reinforce its worldwide distribution network to give the best possible service and support.

In 1966, Pearl introduced its first top-of-the-line outfit, named The President series. Japanese professional players liked the originality of sound and design, and visiting drummers such as Art Blakey, J.C. Heard and many others were exposed to the new Pearl President drums. These drummers offered suggestions, and Mitsuo continued to upgrade equipment and perfect production methods to improve quality and performance. The success of this formula of listening to drummers play the instrument, then utilizing R&D to develop and improve product was evidenced by the high acceptance of Pearl drumsets in the U.S. markets. In later years, Pearl used this same formula to enter the world of marching percussion and flutes.

In 1972, Pearl introduced The Artist kit with fiberglass/wood shells, and shortly after introduced The President Export with 100% fiberglass shells. The following year, The Crystal Beat, with seamless acrylic shells was introduced. Impressed by the diversity of shells and the quality of Pearl products, artists such as Louie Bellson, Shelly Manne, Ed Shaughnessy, Cozy Cole, Larrie Londin, and Peter Criss (just to name a few) made the switch to Pearl.

In 1976, Pearl's first all-Maple shell kit, The Giant Step, made its debut in Japan, followed by the Giant Step Artist in 1978 with fiberglass-lined Maple shells. These kits received critical acclaim and helped solidify Pearl's

reputation as a top global brand of drums.

In 1981, Pearl introduced The Blues Flavor with 100% Birch shells, followed by the ground-breaking CZX kit in 1988 with 8 ply 10mm and 10 ply 12.5mm thick 100% Maple shells to satisfy the demands of studio drummers who were seeking the massive sound that only The CZX could produce.

In the 90's, as digital technology attained sound reproduction with accuracy never before possible, drummers sought more traditional, natural sounds from their drums. Always responsive, Pearl met this demand with The Classic Maple shell, with thinner Maple shells with reinforcement rings for a full-bodied, natural sound, ideal for recording. This was closely followed by The Masters series, with Maple, Birch and African Mahogany shells for the broadest spectrum of sounds available to fulfill the needs of drummers of every musical genre.

In 1999, Pearl introduced Masterworks, Pearl's completely custom, 100% handmade drums. With Masterworks, the player for the first time had total freedom to create the drumset of hi/her dreams; freedom to choose the type of wood—either the same wood or blends of Maple, Birch, and African Mahogany—the thickness and depth of the shells, as well as the hardware and color to create a one-of-a-kind instrument custom-tailored to the player's exacting requirements.

In 2002, Pearl began a massive project to determine the optimum thickness, optimum wood composition, and optimum bearing edge for each drum in a drum kit. Dozens of prototypes (incorporating lessons learned from Masterworks) were made and painstakingly evaluated by a panel of professional drummers through "blindfold" listening tests. Final testing was done in actual recording sessions, where the sound was overwhelmingly praised for its incredibly balanced sound. After two and a half years of research, The Reference Series made its debut in 2005, immediately winning the prestigious Musikmesse International Press Award for "Best Drum Set."

Since 1945, Pearl's mission has been to be the absolute best; to have the best quality, the best functionality, the best durability and the best sound. Research is constant and uncompromising in the pursuit of being the best, and when it comes to sound, Pearl's determination to explore new and innovative shell materials and develop innovative new shell-making techniques (such as our Superior Shell Technology) is relentless. Pearl's commitment to quality, innovation and sound has set the direction of the drum set industry of today, and will surely dictate where the industry goes in the future.





Extreme Strength | Optimal Resonance | Superior Tone

Pearl's Superior Shell Technology utilizes a proprietary technique for achieving the ultimate air chamber. It begins with select woods chosen for their unique acoustic attributes, milled to precise thickness with overlapping scarf joint seams for a perfect air-tight fit. The wood plies are saturated with Pearl's proprietary "AcoustiGlue" that permeates every pore and dries to the exact consistency of the wood for optimum resonance. Finally the plies are formed in high-temperature molds with 1000 PSI of hydraulic pressure to produce perfect drum shells that exhibit superior tone, optimal resonance and extreme strength.

Scarf Joints

Our Scarf Joint seams provide 800% greater surface area than conventional butt joints. This provides extreme strength and integrity to the shell while simultaneously eliminating air pockets that can disrupt vibration, so the shells vibrate uniformly for superior resonance. Other companies use butt joints where the seams are simply butted together. A butt joint works if the ends meet exactly, but often they don't and a gap is formed. Within the gap is air which is an excellent insulator. Air stops sound. For example, recording studios are built with a room within a room with air separating the two to stop sound from interfering with recordings. This is great for studios but not for drums. As drummers we want drums to vibrate freely and evenly without air pockets to impede vibration. With S.S.T., our use of scarf joints ensures no gaps and no air pockets, so the shells vibrate fully and uniformly for superior resonance.

Proprietary "AcoustiGlue"

"AcoustiGlue" is Pearl's special proprietary adhesive that hardens within the shell to the same density as the wood it binds, thus allowing the shells to respond as if they were made from a single-ply of wood. During shell formation the hydraulic mold is heated and the glue is

literally boiled into the pores of the wood to ensure complete adhesion. Simultaneously, 1000 PSI is applied for thorough bonding of the plies to create the finest drum shell in the world. No other system uses this perfect combination of heat and pressure to ensure a perfect drum shell with extreme strength and tonal character. Now we have a perfect, gapless air chamber. The shell is then trimmed and the ends squared to assure overall tuning consistency and head seal.



Bearing Edges

This critical step is another key component in the quality of our shells. Our standard edges feature a 45° angled bearing edge on the inner diameter with 45° backcut over the second ply on the outside of the shell for a highly focused contact point, providing outstanding balance between attack and resonance. Our Reference drums feature rounded 45° edges on 8" to 13" toms and fully rounded edges on drums 14" and larger for more head-to-shell contact area for maximum shell vibration and resonance.

A Brilliant Finish

Finally Pearl's signature finish is applied to the drum. Pearl's painting process matches beauty with durability. Whether it's a custom Masterworks finish, designed to your exact specifications, or the 31-step super high gloss finishes found on Reference and Masters Premium - your drums will look as good as they sound for years to come.

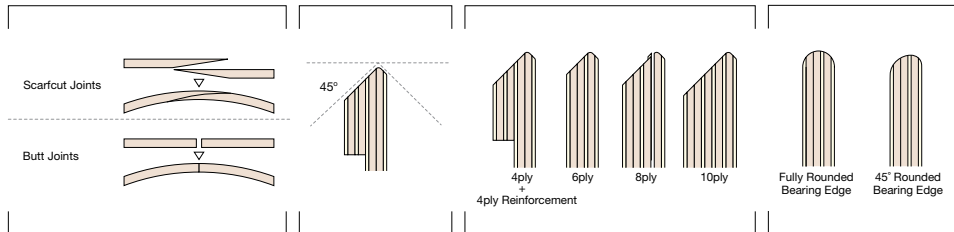

Pearl's Superior Shell Technology Assures Manufacturing Excellence. Every Time.

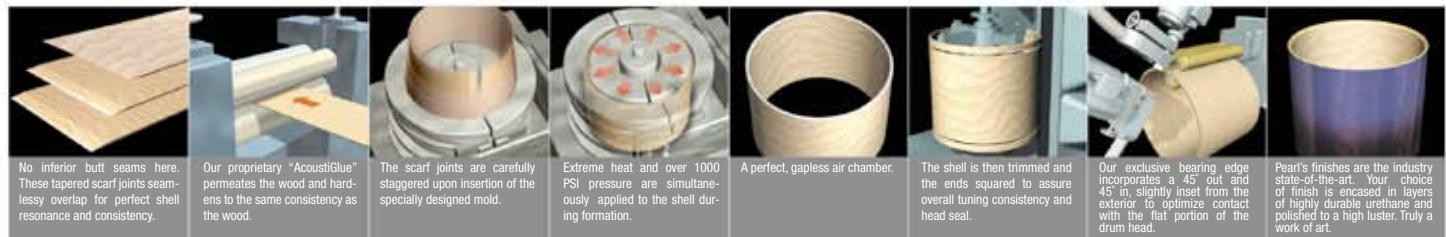

No inferior butt seams here. These tapered scarf joints seamlessly overlap for perfect shell resonance and consistency.

Our proprietary "AcoustiGlue" permeates the wood and hardens to the same consistency as the wood.

The scarf joints are carefully staggered upon insertion of the specially designed mold.

Extreme heat and over 1000 PSI pressure are simultaneously applied to the shell during formation.

A perfect, gapless air chamber.

The shell is then trimmed and the ends squared to assure overall tuning consistency and head seal.

Our exclusive bearing edge incorporates a 45° out and 45° in, slightly inset from the exterior to optimize contact with the flat portion of the drum head.

Pearl's finishes are the industry state-of-the-art. Your choice of finish is encased in layers of highly durable urethane and polished to a high luster. Truly a work of art.

At first glance, the world today may seem full of great drum companies, but when you look closely you'll see there's really only one. Pearl.

Chad Smith
Red Hot Chili Peppers

"Hard Work and Passion... A Little Luck... 20 Years Together and The greatest drums on the planet. Me and Pearl."

PEARL DRUM HARDWARE

The Perfect Compliment to a Great Set of Drums

The same tireless pursuit of perfection that goes into our legendary drums is found in our hardware. Hardware designed to maximize the sound of your drums. Pearl Hardware has set the standard for strength, durability and innovation. It's the choice of working professionals who depend on their equipment. Surefooted on stage or in the studio, when the show must go on, count on Pearl hardware.



Golden Ratio for Air Vents (Masterworks, Masters Premium)

The Golden Ratio, also known as the Golden Section, Golden Mean, Golden Rectangle, and the Divine Proportion, has fascinated mathematicians since the time of the Pharaohs. It is a mathematical constant (1.61803) that is found repeatedly in nature and has been used by artisans for generations to create art and structures with pleasing proportions. Stradivarius applied the Golden Ratio to define the location of the "f-holes" and proportions of his masterwork violins. The exterior dimensions of the Parthenon are said to form a perfect Golden Rectangle. The proportions found in Leonardo da



Omar Hakim
Studio Legend

“What’s really great about Pearl is that they make all their drum-sets. They don’t outsource to another company. Every series is manufactured by the skilled professionals at Pearl Drums.”

Pearl’s Innovative Features

Lug Design

Bridge style lugs and floor tom brackets provide maximum resonance with minimal shell contact. Pearl’s revolutionary BRL lugs assure the ultimate in head seating and tuning integrity. The unique swivel function allows the tension rods to align perfectly into the lugs so there’s no lateral pressure against the hoops, thus assuring maximum resonance and sustain.

Floor Tom Leg Brackets Air Suspension Rubber Tips

Full height adjustment with our built in memory lock keeps floor tom positioning perfectly set. Our patented Air Suspension Rubber Tip allows your floor tom to rest on a cushion of air. These large rubber feet prevents premature sound decay from floor contact. Floor toms never has it so good.

OptiMount Suspension System

The OptiMount Suspension System provides tom mounting with zero shell contact for ultimate resonance. By attaching to the tension bolts via isolated rubber bushings the shell is allow to float which in turn allows it to sing to its fullest capabilities.

MasterCast Die-Cast Hoop

Our die cast hoops offer state-of-the-art head seating and tuning capabilities thanks to their structural strength and precision manufacturing technique. The MasterCast

Hoop system prevents binding and allows the shell to resonate to its absolute fullest potential.

Bass Drum Claw Hook

Our bass drum claws incorporate rubber hoop isolators for scratch prevention on lacquered hoops, provide evenly distributed clamping force for consistent tuning. The key bolts are recessed for snag-free fit in carrying cases and to eliminate accidental detuning.

Bass Drum Spur

Our telescoping spurs feature rubber or spike tips for maximum traction control. The high-grip rubber tip can be retracted to allow a recessed spike to be exposed for maximum “bite” on carpeted surfaces.

Stainless Steel Tension Bolts

Pearl’s stainless steel tension rods are machined from a single piece of stainless steel to the most exacting tolerances in the industry. They feature super smooth and precise tensioning with absolutely no play. Each is matched with a precision-machined brass swivel nut for ultra-precise performance.



Lug Design for Reference



MasterCast Die-Cast Hoop



Floor Tom Leg Bracket
Air Suspended Rubber Tip



Bass Drum Claw Hook



Optimount Suspension System



Bass Drum Spur

Vinci’s “Last Supper” follow the Golden Ratio. Intrigued by this, our engineers asked if the Golden Ratio was applicable to drums and more specifically to the location of the air vents. For every drum depth there’s an upper and lower Golden Ratio location, and testing revealed that the upper location noticeably improves attack, which is perfect for snare drums, while the lower position improves low frequency response, which is ideal for toms and bass drums. Pearl’s revolutionary new Golden Ratio air vents are so unique they’re patent pending. Experience the sound of Golden Ratio air vents, centuries in the making, exclusively on Masterworks and Masters Premium, exclusively from Pearl.







Completely Custom, Totally Handmade, Pearl Drums

With no assembly line boundaries and no mass production compromises,
Masterworks drums truly represent all that is possible.

Each drum is a work of art, constructed by seamlessly blending the artisan qualities and wisdom of hand craftsmanship,
with the technology and precision of state of the art custom built machinery. There is no inventory.

Every drum in your kit is designed by you, and hand built to your exacting specifications, one drum at a time.

We've assembled an elite group of Pearl master craftsmen in order to manufacture the finest drums the world has ever known.

Masterworks drums are as individual as you are, and like no other you have heard or seen before.



Drummer's Dream Come True

Pearl's Masterworks Series represents the fruition of over 60 years of acoustic drum research and craftsmanship. When you choose Masterworks, you're selecting drums that epitomize exactly what you want in a set of drums. Why? Because you design them. From shell thickness and composition to exterior finish and hardware plating, Masterworks is the only completely custom drumset available. There's no inventory, no pre-fabricated shells sitting on a shelf. Every drum in your kit is designed by you and built to the most exacting tolerances by the world's finest master craftsmen using the industry's most advanced custom-built machinery. Completely custom. Totally handmade. It's a musician's dream come true. Whatever your musical style, Masterworks can build a kit to express every nuance of your individual style. With Masterworks, it's about choices. The choices begin with the selection of the

shell material that precisely suits your playing style. Maple is an excellent choice for general purpose applications due to its smooth, warm, well rounded tone, with equal amounts of hi-end attack and mid-range body, and an excellent low-end punch. Birch is known for its "naturally EQ'ed sound" that offers slightly boosted hi-end frequencies, a smooth, mellow mid-range and a deep low-end presence and is a great choice for any applications that requires extra presence and cut. African mahogany is the ideal choice when maximum warmth and low frequencies are a priority.



Choosing the Wood for the Shell



Maple

Maple has been a favorite choice of drum manufacturers since the late 1700's. Its grain is a beautiful canvas for transparent finishing techniques and its tone is ideal for general purpose, all encompassing applications. Our North American Maple, like all of the woods used for Masterworks drums, is hand-selected to meet stringent requirements for proper density, age, and consistency of grain and color. Maple offers

a smooth, warm, well rounded tone, with equal amounts of hi-end attack and mid-range body, and an excellent low-end punch. Most drum manufacturers offer some form of 100% Maple drum today as it has become the standard of the industry for high end drum sets.

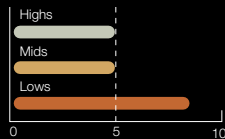

Features slightly boosted lows with smooth mid and high frequencies. Ideal for all around applications.



Composite Shell

The beauty of Masterworks is the ability to custom configure a kit down to the wood plies used for the shells. A composite shell, featuring more than one wood, is a great way to blend the characteristics offered by different materials. For instance, you may choose outer plies of Maple or Birch for their ease of finishing, beautiful grain and sound characteristics, and inner plies of African Mahogany to boost bass and low end punch. While

this is a very popular Masterworks composite, remember there is no wrong way to configure your shell and each drum in your kit can be different if you so choose. The only requirement is that plies must be specified in groups of 2, as in 2 outer plies of Maple plus 2 inner plies of African Mahogany, for a 4 ply shell.



Birch

Birch drums have gained an almost cult following over the years which started around the 1970's. Their "naturally EQ'ed sound" offers the perfect alternative to the overall smoothness of Maple. Many professional players today prefer the sound of Birch to any other material in use for the manufacture of drums. Our prime Scandinavian Birch offers a slightly boosted hi-end cut, a smooth, mellow mid range and a deep low end presence. Many popular Birch shell

drums have found their way to recording studios where they are a favorite of both the player and engineer. Their sound translates equally for both live and recorded situations as Birch drums are a great choice for any application that requires extra presence and cut.

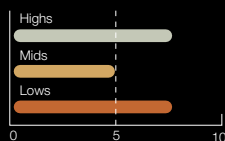

Features boosted high frequencies, slightly reduced mids, and a good low end punch. Ideal for applications requiring extra focus and cut.



African Mahogany

Mahogany was the industry standard for drum shell manufacture for over fifty years and one listen will tell you why. Our supreme quality African Mahogany is extremely rich in low-end frequencies, with beautifully smooth mids and a slight roll-off in the higher register. Drums made from African Mahogany have warmth and body that sets them apart from all others. Few companies today offer this excellent wood for drum shells

simply because its porous exterior is extremely difficult to finish and it costs more than Maple. Without question, if your main requirements are "bottom" and punch, African Mahogany should be your wood of choice.

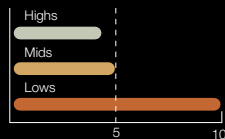

Features extremely rich low end frequencies, with beautifully smooth mids and a slight roll-off in the higher frequencies. Ideal for applications requiring ultimate warmth and body.

Carbon Ply

If you desire something more futuristic, we offer the cutting

edge of drums with Carbon Fiber. This ultra exotic hybrid features 6 plies of 5.4mm Maple sandwiched between an inner and outer ply of Carbon Fiber. These drums produce a sound that goes beyond description and must be experienced.



Artisan Finishes

Complete your Masterworks masterpiece with your choice of our peerless Masterworks Artisan finishes or stunning super high gloss lacquer finishes. Artisan exotic wood veneers offer gorgeous one-of-a-kind looks to set your kit apart from all others.

Highly figured woods are available including Bubinga, Tamo, Eucalyptus, Flame Maple

and Burl Mahogany. Our super high gloss lacquer finishes are hand-applied over a week's time with multiple coats for a "mile-deep" look that you'll treasure and others will envy.





Shell Thickness Options

With Masterworks you can choose the thickness of your shells to precisely tailor the sound to your exact needs. Thin shell drums offer great resonance and maximum tone that can be most appreciated in near-field applications. Thick shells are extremely "efficient" and provide ultimate volume and projection. These drums are ideal for any application requiring high sound pressure levels with maximum cut. Medium thickness shells offer a very good compromise between volume and resonance and are ideal for general purpose applications. With Masterworks, each drum can be crafted with a different thickness to precisely achieve the sound you want...the choice is yours.

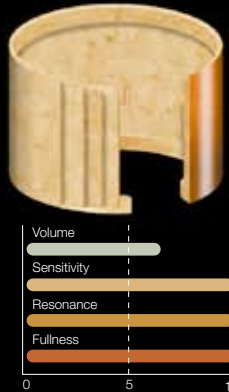

Thin shells drums offer great resonance and maximum tone that can be most appreciated in near-field situations.

Thin

Thin shell drums have become extremely popular in recent years as their sound offers the best "near field" or player's experience. Our 4 ply, 5mm shell enables relatively easy energy transfer from the heads to the shell, thus causing the shells to fully vibrate. This vibration imparts a very rich, warm "wood" tone to the overall sound that can be most appreciated close to the kit while it's played. This effect is also great for recording where miking techniques can capitalize on the warmth and natural tone of the instrument. Most manufacturers offer a thin shell hi-end drum series, and Pearl's Masters Premium MMP/BMP Series drums are a perfect representation. Our 4 ply, 5mm shell also features an extra 4 ply, 5mm reinforcement ring at both top and bottom to help strengthen the shell and add support at critical head contact points for stability.

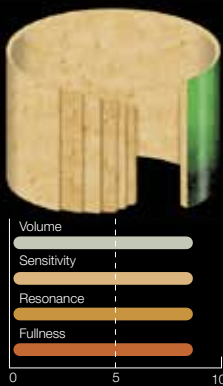

Medium

Medium thickness drums, as with our 6 ply, 7.5mm Masters MCX shells, have slightly greater stiffness and resist some of the energy transfer from the heads. With slightly less vibration, a trade-off is achieved allowing the sound to be slightly "cooler" than a thin shell drum, but with greater volume and projection. These drums represent a great choice for all around, general purpose applications, offering a warm, full bodied wood tone, with great attack, loudness and presence. Medium thickness shells may offer the best of both worlds providing the perfect compromise between resonance and volume.

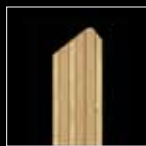

Medium thickness shells are ideal for general purpose applications and/or situations requiring more "horsepower." They offer a very good compromise between volume and resonance.

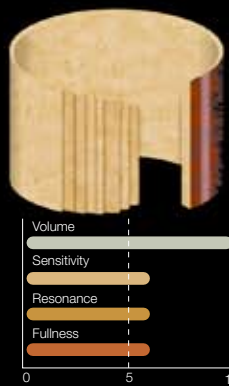

Thick

Thicker shell drums are extremely "efficient" and allow most of the player's energy to be focused through the heads directly to the audience. Since the shell provides greater mass, less volume is lost through the shell in the form of resonance. They offer good tone and warmth but at reduced levels compared to their thinner shell counterparts. These drums are ideal for coliseum-type venues and other applications requiring high sound pressure levels and ultimate volume. Masterworks drums are available in both an 8 ply, 10mm thickness and a 10 ply, 12.5mm thickness. Snare drums made in these thicknesses rival metal snare drums in intensity and projection, providing a great cannon-like crack with extreme volume.



Thick shells are extremely "efficient" and provide ultimate volume and projection. These drums are ideal for any application requiring high sound pressure levels with maximum cut.

Bearing Edge Options

Other than the shell material, nothing influences your drum's overall response and tonal spectrum more than the bearing edge. That's why Masterworks gives you three bearing edges from which to choose from.



45 Degrees
Pearl's legendary 45 degree bearing edge delivers the perfect blend of attack and warmth.



Rounded 45
The rounded 45 bearing edge boosts mid to high frequencies as a result of greater head-to-shell contact.



Fully Rounded
The fully rounded bearing edge provides maximum head-to-shell contact for a greatest boost in mid to low range frequencies.

Hardware Color

All Masterworks Series drums are available in your choice of Chrome, Gold, or Black Chrome plated drum hardware finishes to make your kit as unique as you are.



Chrome

Gold

Black Chrome



Masterworks

**Completely Custom.
Totally Handmade by Pearl**



Masterworks Tint Blue

Bass Drum : MWA2218B Tom Tom : MWA1008T, MWA1209T Floor Tom : MWA1414F, MWC1616F Snare Drum : MWA1465S
Hardware & Accessories : S-2000, P-2002C, T-2000, PS-85, BC-2000 (x2), BC-1000 (x3), H-2000



Todd Sucherman
Styx

“Being able to design your own drums in the Masterworks line is truly a dream come true.”



Michael Cartellone
Lynyrd Skynyrd

“I’m proud to say I’ve been a Pearl endorser for almost twenty years. Not only have they provided me with the best drums on the market, more importantly, they’ve stood by my side with loyalty and friendship.”

Masterworks Black Cherry

Bass Drum : MW2218B Tom Tom : MW0807T , MW1008T, MW1209T Floor Tom : MW1515F Snare Drum : MWA1450S
Hardware & Accessories : H-2000, S-2000, P-2000C, BC-2000 (x2), TC-2000



Pearl "MasterCast" Head



Reference

**A Complete Set Of Individually Engineered,
Incredible Sounding Drums**

The Reference Mission

To fully understand these drums you must accept that the desired tonal characteristics of a rack tom are completely different than that of a bass drum, and to make these drums with the same composition would result in a compromise. This is the mission behind Reference Series: To create a perfect sounding drum set where every drum is optimally engineered to produce the best sound possible within its respective tonal range and diameter...drum by drum by drum. Forget what you think you know about drums and take a closer look at Pearl's Reference Recipe and the synergy of its three task-specific components.

Reference **Recipe**

Optimized Shell Composition

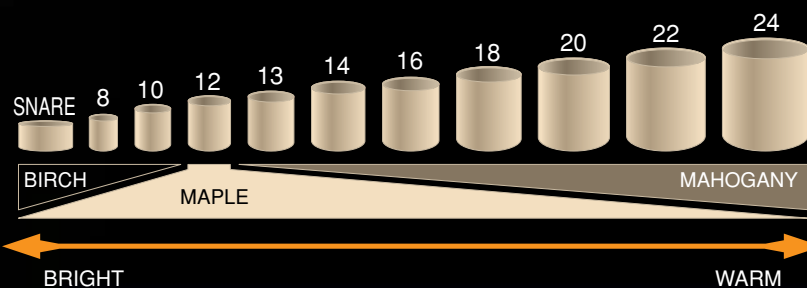

Optimized Bearing Edge

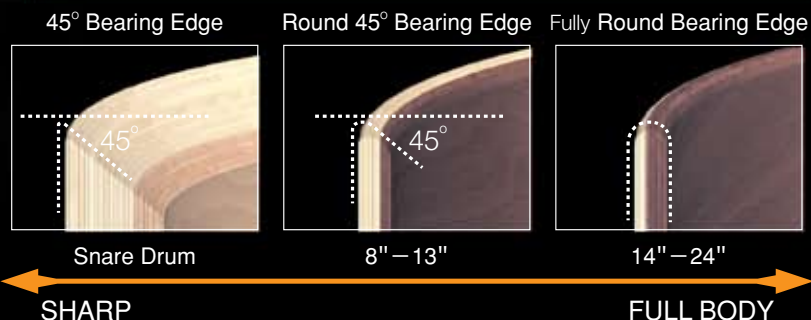

Optimized Thickness

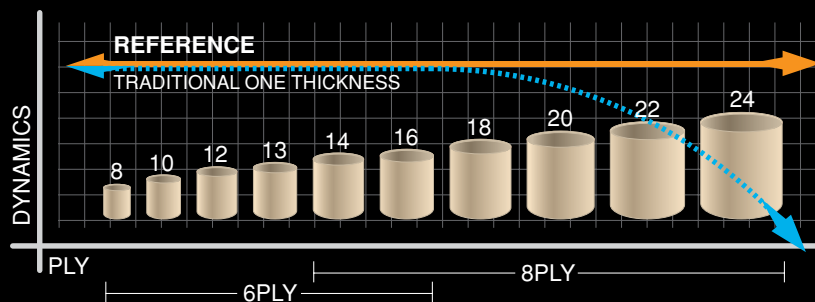

With Reference Series, it's not about compromise, it's about every drum in your kit performing at its optimal capacity.



Reference

Dennis Chambers
Studio Legend

"Pearl Drums Sound Great. Feel Great. And Look Great.
That's All That Matters."



Reference No.193 Purple Craze

Bass Drum : RF2218BX/C **Tom Tom** : RF0808T/C, RF1008T/C, RF1209T/C **Floor Tom** : RF1414F/C, RF1616F/C **Snare Drum** : RF1465S/C, M1040
Hardware & Accessories : H-2000, S-2000(x2), P-2000C(x2), T-2000, TC-2000, BC-2000(x2), B-1000(x3), TL-2000(x3), HH-3, HH-4, PBL-10, PBL-30, PPS-20



Reference No.330 Ivory Pearl

Bass Drum : RF2018BX/C(x2) **Tom Tom :** RF1008T/C, RF1208T/C, RF1309T/C **Floor Tom :** RF1616F/C **Snare Drum :** RF1365S/C, RFB1450
Hardware & Accessories : H-2000, S-2000(x2), P-2000C(x2), TH-2000S(x3), CH-2000(x2), CH-2000S(x5), CH-1000(x2), DR-501(x2), DR-501E(x2), RJ-50, PCX-100(x6), PCX-200, UX-80



Eric Singer

KISS/Alice Cooper

"I have played Pearl Drums for over 22 years and have never even thought about using anything else."

Reference



Reference No.198 Shimmer of Oz

Bass Drum : RF2220BX/C Tom Tom : RF1008T/C, RF1209T/C Floor Tom : RF1414F/C, RF1616F/C Snare Drum : RF1450S/C,
Hardware & Accessories : H-1000K, S-2000, P-2002C, TC-2000 (x2), BC-1000, C-1000

Horacio "el negro" Hernandez
Studio Legend

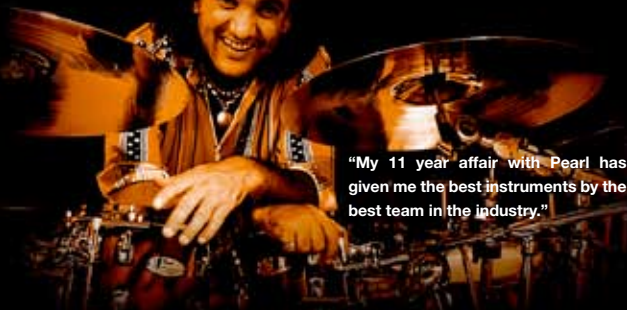

"My 11 year affair with Pearl has given me the best instruments by the best team in the industry."

Reference Specifications

- * Pearl's exclusive SST Superior Shell Technology
- * Light Weight Aluminum OptiMount Suspension System
- * BRL Bridge Lugs w/Swivel Function
- * LB-200 Bridge Type Floor Tom Leg Brackets
- * LG-200 Floor Tom Legs
- * SP-300 Spurs
- * MasterCast Die-Cast Hoops(toms, floor toms)
- * Stainless Steel Tension Rods
- * Remo Clear Emperor Batter Heads
- * Remo Clear Powerstroke3 Bass Drum Batter Head
- * Remo "Window" Snare Batter Head



Hardware Color

All Reference drums are available in your choice of Chrome, Gold, or Black Chrome plated drum hardware.



Virgil Donati
 Legendary Clinician

"Quality of timbre, resonance and articulation, have a vital effect on my playing when I sit behind a set of drums. In every environment from stadiums to small clubs, I need an instrument that can consistently project the detail and expression of my playing... my instrument is Pearl."



Reference No. 102 Natural Maple

Bass Drum : RF1814BX Tom Tom : RF1208T, Floor Tom : RF1414F Snare Drum : RF1450S
 Hardware & Accessories : H-72W, S-70W, P-2000C, BC-100S(x3), TH-2000S, AX-20

Shell Composition



8" & 10" 6 ply
 Maple 4 Birch 2

12" 6 ply
 Maple 6

13" ~ 15" 6 ply
 Maple 4 Mahogany 2

16" 6 ply
 Maple 2 Mahogany 4



14" & 15" 8 ply
 Maple 4 Mahogany 4

16" & 18" 8 ply
 Maple 2 Mahogany 6

18" & 20" 6 ply
 Maple 2 Mahogany 4

22" & 24" 8 ply
 Maple 2 Mahogany 6

Reference Model Numbers

Specification Chart

Bass Drum

24" x 18"	RF2418BX/C	(BB/C)
24" x 16"	RF2416BX/C	(BB/C)
22" x 20"	RF2220BX/C	(BB/C)
22" x 18"	RF2218BX/C	(BB/C)
22" x 16"	RF2216BX/C	(BB/C)
20" x 18"	RF2018BX/C	(BB/C)
20" x 16"	RF2016BX/C	(BB/C)
20" x 14"	RF2014G/C	(w/BT-3 x 2)
18" x 16"	RF1816BX/C	(BB/C)
18" x 14"	RF1814BX/C	(BB/C)

Floor Tom

14" x 14"	RF1414F/C
16" x 16"	RF1616F/C
18" x 16"	RF1816F/C

Tom Tom

8" x 7"	RF0807T/C
8" x 8"	RF0808T/C
10" x 8"	RF1008T/C
10" x 9"	RF1009T/C
10" x 10"	RF1010T/C
12" x 8"	RF1208T/C
12" x 9"	RF1209T/C
12" x 10"	RF1210T/C
13" x 9"	RF1309T/C
13" x 10"	RF1310T/C
13" x 11"	RF1311T/C
14" x 10"	RF1410T/C
14" x 11"	RF1411T/C
14" x 12"	RF1412T/C
15" x 13"	RF1513T/C
15" x 14"	RF1514T/C
16" x 13"	RF1613T/C
16" x 14"	RF1614T/C



Masters
PREMIUM

The Legendary Sound of Pearl

Masters Premium

For more than two decades, the legendary Pearl Masters sound has been heard on countless recordings and in the world's top recording studios. The Masters sound is synonymous with legendary drummers like Jeff Porcaro, Dennis Chambers and many others. The Pearl Masters Premium Series offers the discerning player precision, beauty, innovation and options. This special order series is available in your choice of 4 ply or 6 ply 100% Maple or 100% Birch shells, and features upgraded lowmass aluminum OptiMounts, Masterworks/Reference bass drum spurs, bass drum claws, floor tom legs and leg brackets. Masters Premium snare drums feature Pearl's premium swivel tube lugs that assure perfect tension rod to lug alignment. All Masters Premium drums feature Pearl's innovative Golden Ratio air vents for improved low end response on toms and bass drums and improved attack on snare drums. You can choose from a total of 34 finishes including 26 super high gloss lacquer finishes and 8 premium coverings. All shells are constructed using Pearl's exclusive SST Superior Shell Technology manufacturing process.

Masters Premium MMP / BMP 4ply

Pearl's 4 ply shells with 4 ply reinforcement hoops produce a "vintage" sound with deep, rich tone and incredible sensitivity.



MMP
4ply [Maple]
with 4ply Reinforcement Rings

BMP
4ply [Birch]
with 4ply Reinforcement Rings

Masters Premium MRP / BRP 6ply

Our classic 6 ply shells have more attack and power for outstanding presence on stage and in the studio.



MRP
6ply [Maple]

BRP
6ply [Birch]



Masters
PREMIUM



Masters Premium MMP No.333 Purple Metallic

Bass Drum : MMP2016BX/C Tom Tom : MMP1008T/C, MMP1209T/C Floor Tom : MMP1616F/C Snare Drum : MMP1465S/C
Hardware & Accessories : H-2000, S-2000, P-2000C, TC-2000(x2), B-1000, C-1000



"Being with Pearl Drums reminds me of a great P.O.D. lyric: 'Straight up roll with the pack or get left behind.'"

Masters Premium Specifications

MMP / BMP / MRP / BRP

Pearl's exclusive SST Superior Shell Technology

- * Light weight Aluminum OptiMount Suspension System
- * Golden Ratio Air Vents
- * Bridge Type Masters Lugs
- * Masterworks/Reference Bass Drum Spurs, Claws, and Bridge Leg Brackets and Legs
- * MasterCast Die-Cast Hoops (toms, floor toms)
- * Stainless Steel Tension Rods
- * PowerStroke 3 White Coated Bass Drum Head (in front)



Hardware Color

All Masters Premium Series drums are available with Chrome, Black Chrome, or Gold plated drum hardware.



Ricky Lawson
Studio Legend



Masters Premium MRP No.331 Black Pearl

Bass Drum : MRP1814BB/C Tom Tom : MRP1208T/C Floor Tom : MRP1414F/C Snare Drum : MRP1455S/C
Hardware & Accessories : H-1000, S-2000, P-1000 , TH-2000I, BC-100S(x3)



Golden Ratio Air Vents



Light weight Aluminum OptiMount Suspension System

Masters Premium Colors

Choose from 26 super high gloss lacquer finishes, 5 premium Delmar coverings, and 3 Delmar "glass glitter" coverings with real glass flakes.



GONG DRUM

Pearl's "Gong Drum" features a 20"x14" stick-playable single-headed bass drum with twin oppositely mounted BT-3 brackets for aerial mounting. Available in Reference and Masters.

20"x14" RF2014G/C
20"x14" MMP2014G/C
20"x14" BMP2014G/C

Masters Premium Model Numbers

Specification Chart

Bass Drum	
24" x 18"	2418B
24" x 16"	2416B
22" x 20"	2220B
22" x 18"	2218B
22" x 16"	2216B
20" x 18"	2018B
20" x 16"	2016B
18" x 16"	1816B
18" x 14"	1814B

Floor Tom	
14" x 14"	1414F
16" x 16"	1616F
18" x 16"	1816F

Tom Tom	
8" x 7"	0807T
8" x 8"	0808T
10" x 8"	1008T
10" x 9"	1009T
10" x 10"	1010T
12" x 8"	1208T
12" x 9"	1209T
12" x 10"	1210T
13" x 9"	1309T
13" x 10"	1310T
13" x 11"	1311T
14" x 10"	1410T
14" x 11"	1411T
14" x 12"	1412T
15" x 13"	1513T
15" x 14"	1514T
16" x 13"	1613T
16" x 14"	1614T





Masters MCX

Masters MCX features the same 6 ply Maple shells and Masters quality drum hardware as its big brother, Masters Premium MRP. While Masters Premium is special order only, Masters MCX offers four ultra high gloss UV lacquer finishes and three eye-catching "glass glitter" wrapped finishes with real glass flakes, all adorned with chrome drum hardware. Standard features include Masters OptiMounts, MasterCast Die-Cast hoops, spurs, and floor tom brackets / legs. Five very affordable shell packs are available as permanent stock items. Never before has the legendary Masters sound been available to so many.



MCX 6ply [Maple]

Masters
M C X

The Most Affordable Masters Ever

Masters
MCX



Masters MCX No. 363 Black Sparkle Fade

Bass Drum : MCX2218BX/C **Tom Tom :** MCX1008T/C, MCX1209T/C **Floor Tom :** MCX1414F/C, MCX1616F/C **Snare Drum :** MCX1465S/C
Hardware & Accessories : H-1000, S-1000, P-1000, T-2000, B-1000(x2), C-1000(x4)

Berry Kerch
Shinedown

"Pearl Drums hold up to the rigors of the road and the stress of the studio, I have never been happier."

Legendary Sound

The foundation of the legendary Masters sound starts with a 6 ply, 100% select Maple shell. The warm, full tone of Pearl's Maple shell has been the first choice of professional drummers worldwide for decades. At a new low price, the legend lives on with Masters MCX.

Masters MCX Specifications

- * Pearl's exclusive SST Superior Shell Technology
- * OptiMount Suspension System
- * Bridge Type Masters Lugs
- * Standard Masters Bass Drum Spurs, Claws and Bridge Type Leg Brackets
- * MasterCast Die-Cast Hoops (toms, floor toms)
- * Standard Steel Tension Rods
- * Coated PowerStroke 3 Ebony Bass Drum Head (in front)



Masters MCX Color



Mike Wengeren
Disturbed

"There is Nothing I Depend on More.
Together My Pearl Drums and I are Indestructible."



Masters MCX No. 364 Green Sparkle Fade

Bass Drum : MCX2218BX/C Tom Tom : MCX1009T/C, MCX1209T/C Floor Tom : MCX1616F/C Snare Drum : MCX1465S/C
Hardware & Accessories : H-2000, S-2000, P-2000C, TC-2000, TC-1000, B-1000



JUNGLE GIG

The Jungle Gig allows the conversion of virtually any 16" floor to a bass drum. Very portable and perfect for small gigs.



ROCKET TOMS

Rocket Toms are the perfect accent for your kit and can be melodically tuned for dramatic fills.

- 6" x 12" AL-612
- 6" x 15" AL-615
- 6" x 18" AL-618
- 6" x 21" AL-621

#103 Piano Black Lacquer,
#109 Arctic White Lacquer

Jungle Gig Kit
JG-16



Masters MCX Model Numbers

Specification Chart

Bass Drum		Tom Tom	
24" x 18"	MCX2418BX/C	8" x 7"	MCX0807T/C
24" x 16"	MCX2416BX/C	8" x 8"	MCX0808T/C
22" x 18"	MCX2218BX/C	10" x 8"	MCX1008T/C
22" x 16"	MCX2216BX/C	10" x 9"	MCX1009T/C
20" x 18"	MCX2018BX/C	10" x 10"	MCX1010T/C
20" x 16"	MCX2016BX/C	12" x 8"	MCX1208T/C
18" x 16"	MCX1816BX/C	12" x 9"	MCX1209T/C
18" x 14"	MCX1814BX/C	12" x 10"	MCX1210T/C
		13" x 9"	MCX1309T/C
		13" x 10"	MCX1310T/C
		13" x 11"	MCX1311T/C
		14" x 11"	MCX1411T/C
		14" x 12"	MCX1412T/C
		15" x 13"	MCX1513T/C
		15" x 14"	MCX1514T/C
		16" x 13"	MCX1613T/C
		16" x 14"	MCX1614T/C

Floor Tom

14" x 14"	MCX1414F/C
16" x 16"	MCX1616F/C
18" x 16"	MCX1816F/C

VISION

VMX | VBX | VSX & VX |
100% Maple | 100% Birch | Birch Ply

Next Level Perfection

Pearl originally created the now legendary

Export Series to deliver quality drums

at an affordable price.

Export spent the next 20 years

as the number one selling drumset in the world.

The lessons learned from this extraordinary success led

Pearl to create a new series of drums

that far exceeds the standard set by Export.

Welcome to Pearl's Vision Series,

the highest quality drums in their class, period.

The Vision of 6/8

Some companies in the intermediate category have chosen to compromise quality and features in exchange for a low price. Pearl will never make that sacrifice. The Vision Series represents Pearl's commitment to quality by including more professional features while maintaining an affordable price. Vision drumsets feature two very different shell thicknesses: 6 plies on rack toms and 8 plies on bass drums and floor toms, for incredibly balanced sound. Lower frequencies require greater energy, provided by a projection of the higher frequencies produced by smaller drums. Vision's unique 6/8 technology makes this possible. Vision's exclusive two-ply heads are easier to tune, and deliver full, powerful sound right out of the box. With the exception of the Vision Maple shell pack, Vision drumsets feature Pearl's M.I.P.A. (Music Industry Press Association) award-winning 900 series hardware. From the Birch Ply shell of VX to the 100% Maple shell of VMX, Vision is next level perfection for the drummer who can tell the difference.



Vision's Professional Features

• Pearl's Exclusive SST Superior Shell Technology Shell • Infinitely Adjustable "UNI-LOCK" system tom holders (VX comes with TH-88 Gear Tilter Tom Holders) • Professional I.S.S Tom Mounting System • Bridge Type Lugs, Tom holder Base and Leg Brackets (VMX comes with BB-3 tom holder base, LB-40 leg brackets.) • Air Suspension Floor Tom Feet • ProTone Perimeter EQ Bass Drum Heads • VMX, VBX, VSX comes with ProTone 2 ply heads.

Professional 900 Series Hardware

(VSX, VBX, VX)

- Infinitely Adjustable "UNI-LOCK" system cymbal tilter
- Die-Cast Joint w/Stop Lock
- Rattle-less "SureStrut" tripod base (VMX is available in shell pack only. 900 Series Hardware not included.)





Next Level Perfection.

Mike Mangini

Worlds Fastest Drummer

"My relationship with Pearl is dynamic in nature, meaning that both the products and my expression improve and evolve over time. If any type of relationship is to be successful, then it must adapt to its environment and change over time. Pearl does this."



VISION VMX No. 280 Vintage Wine

Bass Drum : VMX2218B/C Tom Tom : VMX1008T/C, VMX1209T/C Floor Tom : VMX1414F/C, VMX1616F/C Snare Drum : VMX1455S/C
Hardware & Accessories : H-1000, S-1000, P-1000, TH-1000(x2), B-1000, C-1000



Vision
Maple

VMX

100% Maple Shell 

Introducing the all-new VMX, Pearl's most affordable 100% Maple shell pack. Maple, known for its warm, rich tone, has long been the choice wood of professional drummers worldwide. Pearl offers 9 standard Shell Pack configurations, more than any other drum manufacturer. Vision Maple shell packs come standard with professional Two Ply heads and a matching 100% Maple snare drum. These incredible sounding drums are offered in 5 exclusive High-Gloss Lacquer Finishes. VMX is available in shell pack only, no hardware included.

Vision VMX Model Numbers
Specification Chart

Bass Drums	
VMX2218B/C	22" x 18"
VMX2018B/C	20" x 18"
VMX2418B/C	24" x 18"
Floor Toms	
VMX1414F/C	14" x 14"
VMX1616F/C	16" x 16"
VMX1816F/C	18" x 16"
Tom Toms	
VMX0807T/C	8" x 7"
VMX1008T/C	10" x 8"
VMX1209T/C	12" x 9"
VMX1310T/C	13" x 10"
VMX1411T/C	14" x 11"
VMX1613T/C	16" x 13"

Vision VMX Color



Matching 6-ply 100% Maple snare drum

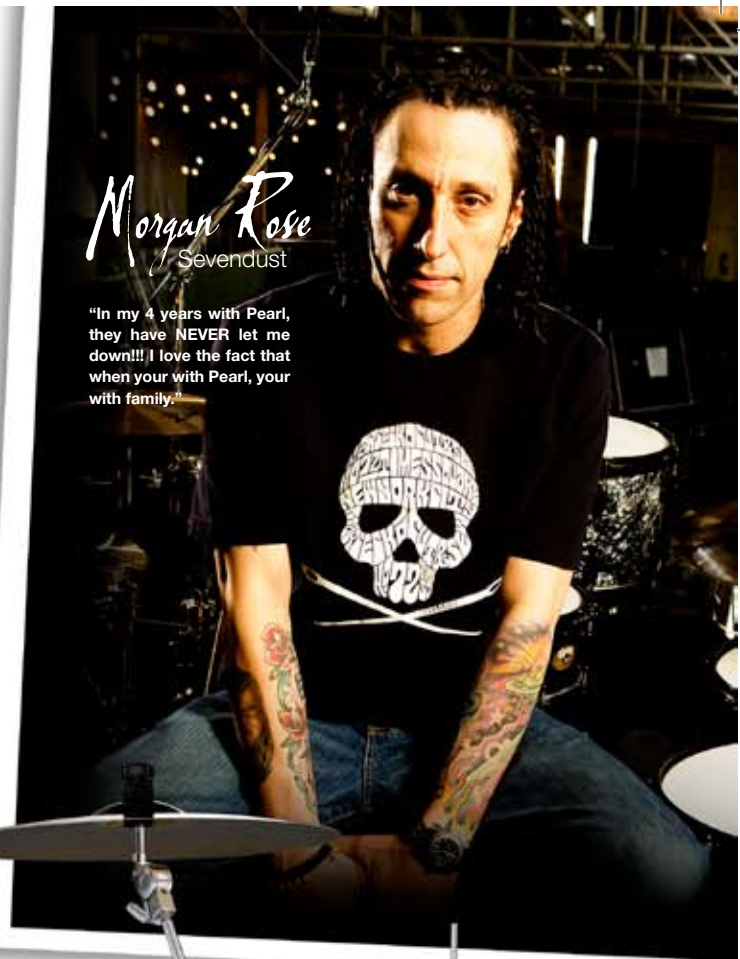

Morgan Rose
Sevendust

"In my 4 years with Pearl, they have NEVER let me down!!! I love the fact that when you're with Pearl, you're with family."



VISION VMX No. 309 Glacier White

Bass Drum : VMX2218B/C Tom Tom : VMX1209T/C Floor Tom : VMX 1414F/C, VMX1616F/C Snare Drum : VMX1455S/C
Hardware & Accessories : H-900, S-900, P-900, TH-1000I, BC-900, C-900



Vision Birch **VBX**

100% Birch Shell

Introducing the all-new VBX, Pearl's most affordable 100% Birch drum set. Birch has long been recognized for its focused, naturally EQ'd sound, ideal for both stage and studio. Pearl offers 9 standard VBX configurations, more than any other drum manufacturer. VBX come standard with professional Two Ply heads, a Steel SensiTone snare drum, and Award-Winning 900 Series Hardware. These incredible sounding drums are offered in 5 exclusive High-Gloss Lacquer Finishes.



Vision VBX Model Numbers Specification Chart

Bass Drums	
VBX2218B/C	22" x 18"
VBX2018B/C	20" x 18"
VBX2418B/C	24" x 18"
Floor Toms	
VBX1414F/C	14" x 14"
VBX1616F/C	16" x 16"
VBX1816F/C	18" x 16"
Tom Toms	
VBX0807T/C	8" x 7"
VBX1008T/C	10" x 8"
VBX1209T/C	12" x 9"
VBX1310T/C	13" x 10"
VBX1411T/C	14" x 11"
VBX1613T/C	16" x 13"

Vision VBX Color

No.230 Clear Birch No.232 Ruby Fade
 No.234 Black Ice No.235 Concord Fade w/Black HW No.236 Orange Zest



VBX drumsets include a SensiTone Steel snare drum

VISION VBX No.235 Concord Fade

VBX925FP/B





Cody Hanson
Hinder

"The bottom line is, no other company
can compete with Pearl!"



VISION VBX No.230 Clear Birch
VBX925/C

Joey Jordison
Slipknot

"I have never played better on a kit than from Pearl.
Absoutely not."





VSX&VX Birch Ply Shell



Based on the original Vision formula, VSX and VX drumsets feature blended Birch Ply shells with 6/8 shell technology. Vision's combination of six-ply rack toms and eight-ply floor toms and bass drums deliver a dynamically balanced sound. Pearl offers 9 standard Vision configurations, more than any other drum manufacturer. VSX and VX come standard with a Brushed Steel SensiTone snare drum, and Award-Winning 900 Series Hardware. VSX offers 6 Ultra-Exotic wrapped coverings, while VX offers 6 more affordable solid color wrap options.



VSX & VX drumsets include a Brushed Steel SensiTone snare drum



VSX

Vision VSX Model Numbers Specification Chart

Bass Drums		Tom Toms	
VSX2218B/C	22" x 18"	VSX0807T/C	8" x 7"
VSX2018B/C	20" x 18"	VSX1008T/C	10" x 8"
VSX2418B/C	24" x 18"	VSX1209T/C	12" x 9"
Floor Toms		VSX1310T/C	13" x 10"
VSX1414F/C	14" x 14"	VSX1411T/C	14" x 11"
VSX1616F/C	16" x 16"	VSX1613T/C	16" x 13"
VSX1816F/C	18" x 16"		

Vision VSX Color



VISION VSX No.431 Strata Black
VSX925S/C

VISION VSX No.444 Orange Sparkle
VSX925S/C

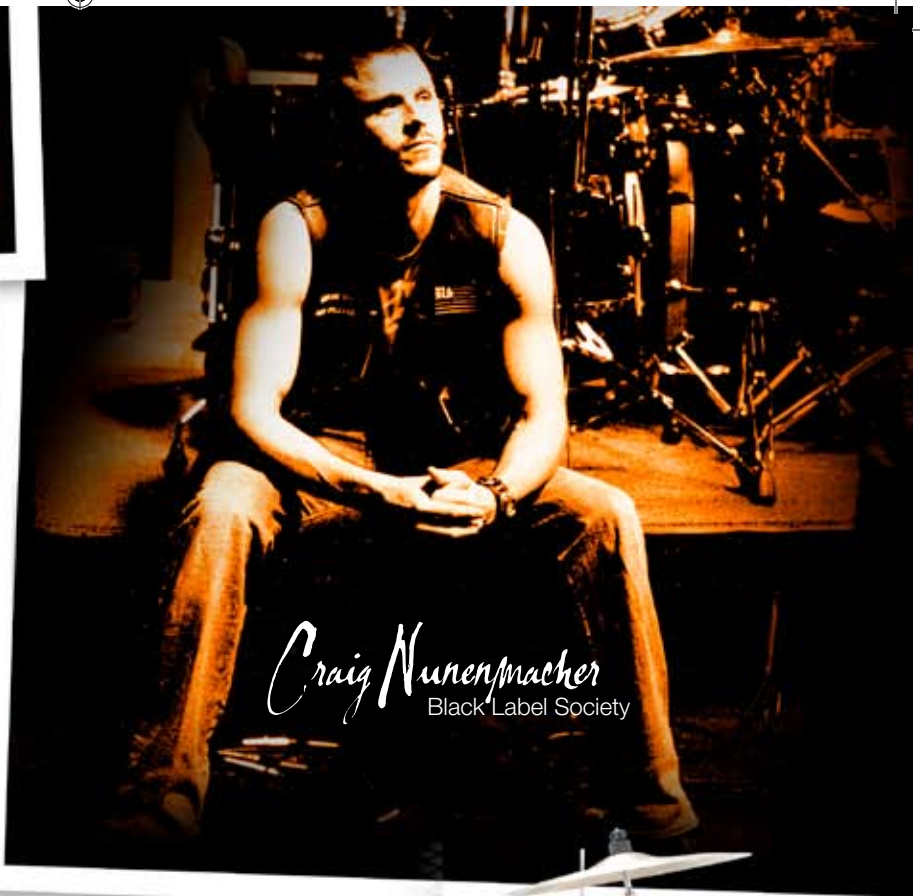

Craig Nunenmacher
Black Label Society

VX

Vision VX Model Numbers Specification Chart

Bass Drums		Tom Toms	
VX2218B/C	22" x 18"	VX0807T/C	8" x 7"
VX2018B/C	20" x 18"	VX1008T/C	10" x 8"
VX2418B/C	24" x 18"	VX1209T/C	12" x 9"
Floor Toms		VX1310T/C	13" x 10"
VX1414F/C	14" x 14"	VX1411T/C	14" x 11"
VX1616F/C	16" x 16"	VX1613T/C	16" x 13"
VX1816F/C	18" x 16"		

Vision VX Color

No. 31 Jet Black w/Black HW	No. 42 Ivory	No. 43 RB Blue
No. 54 Metallic Orange	No. 84 Olive Green w/Black HW	No. 91 Red Wine w/Black HW



VISION VX No. 43 RB Blue
VX924/C

FORUM FZ

Forum Ready-Set-Go! is the all-in-one concept that gets you started in style and ready to rock right out of the box. With new upgrades, Forum is better than ever, and is the ideal choice for the beginning drummer. New features in 2008 include I.S.S. tom mounts, newly designed low-mass lugs, improved cymbals, with a new 16" crash, and the addition of slick black drum hardware, standard on two of the five flashy Forum finishes. Forum comes with rugged double-braced hardware, a heavy duty throne, a pair of Vic Firth drumsticks, and a free DVD with all the set-up, tuning and instructional pointers you'll need to get started. There's no better way to start your drumming career than with Pearl Forum Ready-Set-Go!

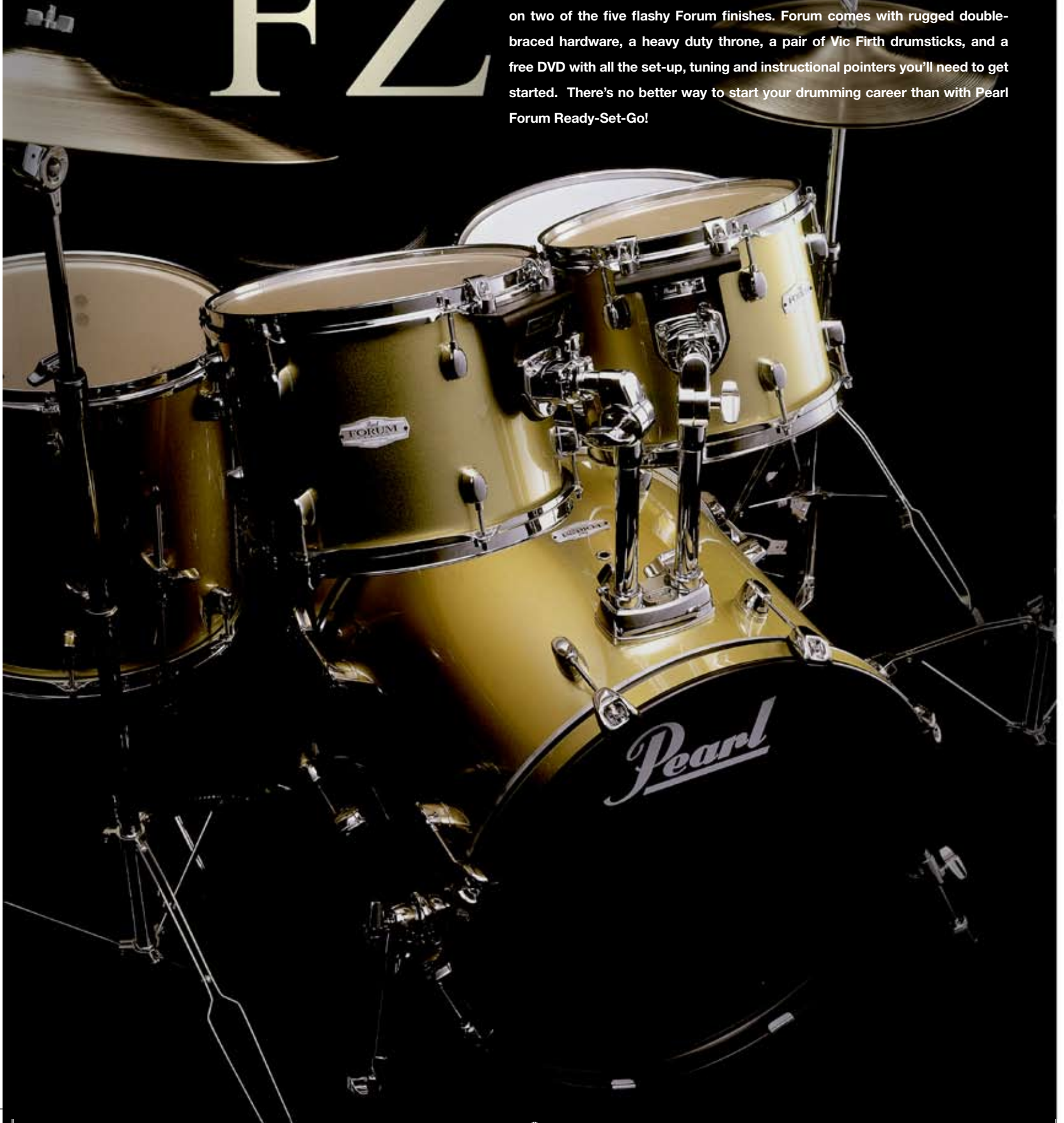



Forum FZ
No.21 Smokey Chrome
FZ725F/C

Forum FZ Model Numbers Specification Chart
/C : Chrome Drum Hardware, /B : Black Drum Hardware

	FZ725F	FZ725	FZ705
Bass Drum	2218B 22"x18"	2218B 22"x18"	2016B 20"x16"
Tom Toms	1008T 10"x8"	1209T 12"x9"	1008T 10"x8"
	1209T 12"x9"	1310T 13"x10"	1209T 12"x9"
Floor Tom	1414F 14"x14"	1616F 16"x16"	1414F 14"x14"
Snare Drum	1455S 14"x5.5"	1455S 14"x5.5"	1455S 14"x5.5"
Ride Cymbal	20"	20"	20"
Crash Cymbal	16"	16"	16"
Hi-Hat Cymbals	14" (1pr.)	14" (1pr.)	14" (1pr.)
Tom Holders	TH-70I (x2)	TH-70I (x2)	TH-70I (x2)
Hi-Hat Stand	H-72W	H-72W	H-72W
Snare Drum Stand	S-70W	S-70W	S-70W
Cymbal Stand	C-70W	C-70W	C-70W
Cymbal/Boom Stand	B-70W	B-70W	B-70W
Drum Pedal	P-120P	P-120P	P-120P
Drum Throne	D-70W	D-70W	D-70W
Drumsticks	Vic Firth 5A	Vic Firth 5A	Vic Firth 5A
DVD	An Introduction to Drumming featuring Eric Singer		

Forum FZ Color



Pearl I.S.S. Mounts

Pearl's I.S.S. tom mounting system removes all mounting hardware from the shell and clamp to the rim providing the quickest and easiest mounting system available today.



Forum FZ
No.31 Jet Black
FZ725/B

Rhythm Traveler



Plastic Heads & Real Cymbals
for Live Playing

Muffle Heads(mesh) & Plastic Cymbals
for Silent Practicing

Easy to transport and easy to practice, the ground breaking concept kit Rhythm Traveler is a gigging and practice kit in one.

This complete 5pc kit includes professional quality 2 ply "ProTone" heads and 13" and 16" cymbals for live performance, and silent mesh heads and plastic cymbals for near-silent practicing.



Rhythm Traveler

Rhythm Traveler Specification Chart
(HCC* : Chrome Drum Hardware, HBC : Black Drum Hardware)

Bass Drum	2008B	20"x8"
Tom Toms	1005T	10"x5"
	1205T	12"x5"
	1405T	14"x5"
Snare Drum	1305S	13"x5"
Crash-Ride Cymbal	CX216	16"
Hi-Hat Cymbals	CX213	13" (1pr.)
Cymbal Pads	RP-CP (x2)	for Ride and Hi-Hat Cymbals
Plastic Cymbals	RP-13PRC (for Ride)	
	RP-13PHH (for Hi-Hat)	
Heads	PTH-13 (Snare Drum)	
	PTH-10/PTH-12/PTH-14 (Tom Toms)	
	PTH-20EQ (Bass Drum)	
Mesh Heads	MFH-13 (Snare Drum)	
	MFH-10/MFH-12/MFH-14 (Tom Toms)	
	MFH-20 (Bass Drum)	
Tom Holders	TH-60 (x2), TH-60S	
Adapter	ADT-2	
Hi-Hat Stand	H-62W	
Snare Drum Stand	S-62W	
Cymbal Stand	C-62W	
Drum Pedal	P-62	

Available Finishes



No.31
Jet Black
w/Black HW



*No.33
Pure White

*Not available in U.S.



Pearl **Snare Drums**

Reference

Reference

Reference Series wood snare drums feature 20 ply shells, with 6 inner plies of Birch and 14 outer plies of Maple, making it one of the loudest wood snare drums available. The 6 inner plies of Birch provides cut and attack while the outer 14 plies of Maple provide warmth and solid midrange punch. The shell's 45 degree bearing edge provides minimum head dampening for intense crack and attack. Reference Series metal snare drums redefine the standard for metal snare drums, just as our wood Reference Series snare

drums did for wood snare drums. Both feature Reference swivel lugs for perfect tension rod alignment, MasterCast die cast hoops, SR-1000 Glide Lock strainer with patented locking lever that prevents the throw-off from disengaging no matter how hard you play, and UltraSound SN-1420D Graduated Tension Snares for extended dynamic range and sensitivity.

Wood Shell

Reference Snare Drums offer a level of performance unattainable before now. 6 inner plies of Birch unite with 14 outer plies of Maple for a staggering 20 ply shell. The 45 degree bearing edge brings all 20 plies to the party in a highly focused sweet spot. This projects the volume that you would expect from such a thick shell without losing sensitivity or articulation. The state-of-the-art in modern hardware adorns these snares to maximize every nuance of the shell construction. Available in 3 sizes to perfectly suit your personal level of performance.



SR-1000
Glide-Lock Strainer
U.S. PAT. 7,220,905/7,301,087



	RF1465S/C		RF1450S/C		RF1365S/C	
Size (Dia. x Depth)	14" x 6.5"		14" x 5"		13" x 6.5"	
Shell	20ply : Maple14 + Birch6		20ply : Maple14 + Birch6		20ply : Maple14 + Birch6	
Hoops	MasterCast (DC1410/1410S)		MasterCast (DC1410/1410S)		MasterCast (DC1306/1306S)	
Lugs	BRL-65		BRL-55		BRL-65	
Rods	10		10		6	
Tension Rods	SST-5047	Stainless Steel Tension Rod	SST-5047	Stainless Steel Tension Rod	SST-5047	Stainless Steel Tension Rod
Strainer	SR-1000	Glide-Lock Strainer	SR-1000	Glide-Lock Strainer	SR-1000	Glide-Lock Strainer
Snares	SN-1420D	Ultra-Sound "D" Type	SN-1420D	Ultra-Sound "D" Type	SN-1320D	Ultra-Sound "D" Type

Brass & Cast Steel Shell

Reference Series offers the most advanced Metal snare drums in the World. The winning combination of extreme sensitivity and powerful volume makes these snare drums a must-have instrument for the working drummer. Whether you choose the "wet and ringy" tone of 3 mm Brass or the brightly assertive 2.5 mm Cast Steel, these drums will satisfy the most demanding of players.



Brass



	RFB1465		RFB1450	
Size (Dia. x Depth)	14" x 6.5"		14" x 5"	
Shell	3mm Brass		3mm Brass	
Hoops	MasterCast (DC1410/1410S)		MasterCast (DC1410/1410S)	
Lugs	BRL-65		BRL-55	
Rods	10		10	
Tension Rods	SST-5047	Stainless Steel Tension Rod	SST-5047	Stainless Steel Tension Rod
Strainer	SR-1000	Glide-Lock Strainer	SR-1000	Glide-Lock Strainer
Snares	SN-1420D	Ultra-Sound "D" Type	SN-1420D	Ultra-Sound "D" Type



Cast Steel



	RFS1465		RFS1450	
Size (Dia. x Depth)	14" x 6.5"		14" x 5"	
Shell	2.5mm Cast Steel w/ Reinforcement		2.5mm Cast Steel w/ Reinforcement	
Hoops	MasterCast (DC1410/1410S)		MasterCast (DC1410/1410S)	
Lugs	BRL-65		BRL-55	
Rods	10		10	
Tension Rods	SST-5047	Stainless Steel Tension Rod	SST-5047	Stainless Steel Tension Rod
Strainer	SR-1000	Glide-Lock Strainer	SR-1000	Glide-Lock Strainer
Snares	SN-1420D	Ultra-Sound "D" Type	SN-1420D	Ultra-Sound "D" Type

Masters

Masters Premium & Masters MCX

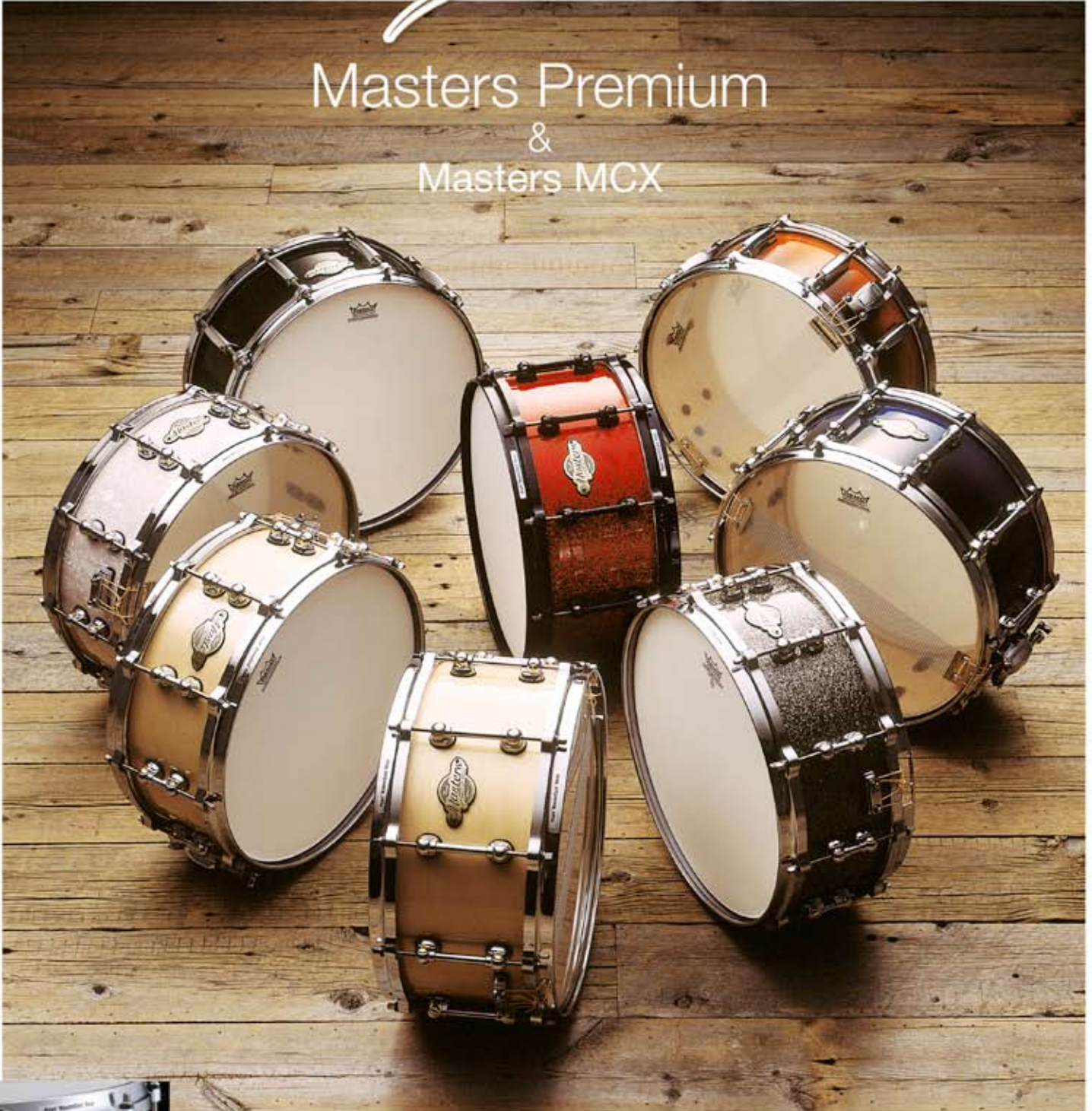

Pearl's Masters Premium Series snare drums feature revolutionary swivel lugs that assure perfect tension rod to lug alignment for optimal head seating and precision tuning. MasterCast die-cast hoops, stainless steel tension rods, innovative "Golden Ratio" air vents for increased attack, and a "vertical pull" SR-017 strainer all come standard on these spectacular snare drums. Masters Premium snare drums are available in a total of 31, finishes including 26 super high gloss lacquer finishes and 8 premium Delmar covered finishes, 3 of which are glass glitter finishes with real glass flakes for incredible radiance.

Masters Premium



MMP1465S/C



MRP1465S/C



BMP1465S/C

Size (Dia. x Depth)	14" x 6.5"	14" x 5.5"	14" x 6.5"
Shell	4 ply Maple w/4ply Maple Reinforcement Rings	6 ply Maple	4 ply Birch w/4ply Birch Reinforcement Rings
Hoops	MasterCast (DC1410/1410S)	MasterCast (DC1410/1410S)	MasterCast (DC1410/1410S)
Lugs	STL-65	STL-55	STL-65
Rods	10	10	10
Tension Rods	SST-5047 Stainless Steel Tension Rod	SST-5055 Stainless Steel Tension Rod	SST-5047 Stainless Steel Tension Rod
Strainer	SR-017	SR-017	SR-017
Snares	S-022N	S-022N	S-022N



BMP1455S/C



BRP1465S



BRP1455S/C

Size (Dia. x Depth)	14" x 5.5"	14" x 6.5"	14" x 5.5"
Shell	4 ply Birch w/4ply Birch Reinforcement Rings	6 ply Birch	6 ply Birch
Hoops	MasterCast (DC1410/1410S)	MasterCast (DC1410/1410S)	MasterCast (DC1410/1410S)
Lugs	STL-55	STL-65	STL-55
Rods	10	10	10
Tension Rods	SST-5055 Stainless Steel Tension Rod	SST-5047 Stainless Steel Tension Rod	SST-5055 Stainless Steel Tension Rod
Strainer	SR-017	SR-017	SR-017
Snares	S-022N	S-022N	S-022N

Masters MCX



MCX1465S/C



MCX1455S/C



MCX1455S/C

Size (Dia. x Depth)	14" x 6.5"	14" x 5.5"	14" x 5.5"
Shell	6 ply Maple	6 ply Maple	6 ply Maple
Hoops	MasterCast (DC1410/1410S)	MasterCast (DC1410/1410S)	MasterCast (DC1410/1410S)
Lugs	CL-65	CL-55	CL-55
Rods	10	10	10
Tension Rods	T-061L	T-062	T-062
Strainer	SR-017	SR-017	SR-017
Snares	S-022N	S-022N	S-022N



SensiTone Elite

SensiTone Elite snare drums offer unparalleled options for the discriminating drummer of today. This series provides a virtual cauldron of advanced metallurgy with a choice of 1mm Steel, 1.2mm Stainless Steel, 1.5mm Brass, 1.2mm Phosphor Bronze and 1.2mm seamless Aluminum. Each of these instruments brings a distinctive sound inherent to its individual aural alchemy. Choosing one will be tough, may we suggest collecting the whole series?



Brass



STE1465BR



STE1450BR

Size (Dia. x Depth)	STE1465BR	14" x 6.5"
	STE1450BR	14" x 5"
Shell	1.5 mm Brass w/Black Nickel Plating	
Hoops	SuperHoop II	
Lugs	STE1465BR	CL-65
	STE1450BR	CL-55
Rods	10	
Tension Rods	SST-5047	Stainless Steel Tension Rod
Strainer	SR-017	
Snares	SN-1420I	Ultra-Sound "I" Type

UltraCast

UltraCast has turned into a modern gothic novel. An experiment gone awry. A monster in the truest sense. We set out to make a precision milled cast Aluminum shell that would project energy and be heard over the chaos of a live band. UltraCast has done that beyond our wildest dreams.

When you hear players like Morgan Rose, Sam Loeffler (Chevelle), and Dave Buckner (Independent), you're hearing the power of UltraCast. Available in 2 sizes, only one attitude.



SR-1000
Glide-Lock Strainer
US.PAT.7220905/7301087



UCA1465/B

Size (Dia. x Depth)	14" x 6.5"	
Shell	3mm Cast Aluminum w/Reinforcement	
Hoops	SuperHoop II (SHB1410B/1410S)	
Lugs	TB-65B	
Rods	10	
Tension Rods	SST-5042	Stainless Steel Tension Rod
Strainer	SR-1000	Glide-Lock Strainer
Snares	SN-1420C	Ultra-Sound "C" Type

Phosphor Bronze

Aluminum

Stainless Steel

Steel



STE1465PB



STE1465AL



STE1465SS



STE1465S



STE1450PB



STE1450AL



STE1450SS



STE1450S

STE1465PB 14" x 6.5"
 STE1450PB 14" x 5"
 1.2mm Phosphor Bronze
 SuperHoop II
 STE1465PB CL-65
 STE1450PB CL-55
 10
 SST-5047 Stainless Steel Tension Rod
 SR-017
 SN-1420I Ultra-Sound "I" Type

STE1465AL 14" x 6.5"
 STE1450AL 14" x 5"
 1.2mm Seamless Aluminum
 SuperHoop II
 STE1465AL CL-65
 STE1450AL CL-55
 10
 SST-5047 Stainless Steel Tension Rod
 SR-017
 SN-1420I Ultra-Sound "I" Type

STE1465SS 14" x 6.5"
 STE1450SS 14" x 5"
 1.2mm Stainless Steel
 SuperHoop II
 STE1465SS CL-65
 STE1450SS CL-55
 10
 SST-5047 Stainless Steel Tension Rod
 SR-017
 SN-1420I Ultra-Sound "I" Type

STE1465S 14" x 6.5"
 STE1450S 14" x 5"
 1mm Steel w/Chrome Plating
 SuperHoop II
 STE1465S CL-65
 STE1450S CL-55
 10
 SST-5047 Stainless Steel Tension Rod
 SR-017
 SN-1420I Ultra-Sound "I" Type



UCA1450/B

14" x 5"
 3mm Cast Aluminum w/Reinforcement
 SuperHoop II (SHB1410B/1410S)
 TB-50B
 10
 SST-5042 Stainless Steel Tension Rod
 SR-1000 Glide-Lock Strainer
 SN-1420C Ultra-Sound "C" Type



The SR-900 Duo-Motion strainer can be converted from side lever action to Gladstone type.

SensiTone Steel (Vision Series)



SS1455S/C

Size (Dia. x Depth) 14" x 5.5"
 Shell Steel w/Chrome Plating
 Hoops 1mm Steel (RIM1408B/1408S)
 Lugs TLS-55
 Rods 8
 Tension Rods TR-5052
 Strainer SR-900 Duo-Motion Strainer
 Snares SNN-142



SH1455S/C

14" x 5.5"
 Brushed Nickel Plated Steel
 1mm Steel (RIM1408B/1408S)
 TLS-55
 8
 TR-5052
 SR-900 Duo-Motion Strainer
 SNN-1



Free Floating System

Pearl Free Floating Snares feature a patented system with no hardware attached to the shells. With nothing to encumber its ringing clarity the shells are free to vibrate with unbridled response and truest articulation. Pearl Free Floating System snare drums are available in several sizes and 4 different shell materials: Brass, Copper, Steel and 6 ply premium Maple. All Free Floaters feature our SR-1000F Glide-Lock Strainer with locking snare tension knob and patented locking throwoff lever that will not loosen no matter how hard you play.



SR-1000
Glide-Lock Strainer
US.PAT.7220905/7301087

Shell	6 Ply Maple	
Size (Dia. x Depth)	14" x 6.5"	
Hoops	MasterCast (DC1410/DC1410S)	
Lugs	FT-65	
Rods	10	
Tension Rods	SST-5042	Stainless Steel Tension Rod
Strainer	SR-1000F	Glide-Lock Strainer
Snares	SN-1420I	Ultra-Sound "I" Type



FM1465/C

Size (Dia. x Depth)	14" x 5"	
Hoops	MasterCast (DC1410/DC1410S)	
Lugs	FT-50	
Rods	10	
Tension Rods	SST-5042	Stainless Steel Tension Rod
Strainer	SR-1000F	Glide-Lock Strainer
Snares	SN-1420I	Ultra-Sound "I" Type



FM1450/C

Size (Dia. x Depth)	14" x 3.5"	
Hoops	MasterCast (DC1410/DC1410S)	
Lugs	FT-35	
Rods	10	
Tension Rods	SST-5035	Stainless Steel Tension Rod
Strainer	SR-1000F	Glide-Lock Strainer
Snares	SN-1420I	Ultra-Sound "I" Type



FM1435/C

FireCracker

When you're ready to add sparks to your playing, the first thing to do is to add a FireCracker snare drum.

As the name implies these explosive powerhouses deliver huge sound from a small package. FireCracker snare drums are available in 12" x 5" and 10" x 5" sizes in your choice of 8 ply Poplar or Steel. Light the fuse and stand back!



Size (Dia. x Depth)	
Shell	
Hoops	
Lugs	
Rods	
Tension Rods	
Strainer	
Snares	

Effect

These versatile drums can be used for secondary effects or as your main snare drum. They're available in a range of sizes to complement any musical style.



	M1040	Sopranino	M1060	Popcorn	M1270	Soprano
Size (Dia. x Depth)	10" x 4"		10" x 6"		12" x 7"	
Shell	6 ply Maple		6 ply Maple		8 ply Maple	
Hoops	1.6mm Steel (RIM1006/1006SL) w/I.S.S.		SuperHoop II (SH1006/1006S)		1.6mm Steel (RIM1208B/1208S)	
Lugs	CL-05		CL-65		CL-100	
Rods	6		6		8	
Tension Rods	SST-5038 Stainless Steel Tension Rod		SST-5035 Stainless Steel Tension Rod		SST-5047 Stainless Steel Tension Rod	
Strainer	SR-018		SR-018		SR-018	
Snares	S-032N		S-032N		S-031N	

Brass

Copper



FB1465/C



FC1465/C



FB1450/C



FC1450/C



FB1435/C



FC1435/C

Shell

Steel

- 14" x 3.5"
- 1.6mm Steel (RIM1410B/1410S)
- FT-35
- 10
- T-060
- SR-1000F Glide-Lock Strainer
- SN-1420I Ultra-Sound "I" Type
-



FB1435B/C



FCS1050



FCS1250



FCP1050



FCP1250

- 10" x 5"
- 1.0mm Steel
- 1.6mm Steel (RIM1006/1006SL)
- CL-50
- 6
- T-062
- SR-018
- S-032

- 12" x 5"
- 1.0mm Steel
- 1.6mm Steel (RIM1206/1206S)
- CL-50
- 6
- T-062
- SR-018
- S-031

- 10" x 5"
- 8ply Poplar
- 1.6mm Steel (RIM1006/1006SL)
- CL-50
- 6
- T-062
- SR-018
- S-032

- 12" x 5"
- 8ply Poplar
- 1.6mm Steel (RIM1206/1206S)
- CL-50
- 6
- T-062
- SR-018
- S-031



B1330

Piccolo



S1330B

Piccolo



M1330

Piccolo



M1440

Piccolo

- 13" x 3"
- Brass
- 1.6mm Steel (RIM1308B/1308S)
- CL-05
- 8
- T-055
- SR-018
- S-029N

- 13" x 3"
- Steel
- 1.6mm Steel (RIM1308B/1308S)
- CL-05
- 8
- T-055
- SR-018
- S-029N

- 13" x 3"
- 6 ply Maple
- 1.6mm Steel (RIM1308B/1308S)
- CL-05
- 8
- T-055
- SR-018
- S-029N

- 14" x 4"
- 6 ply Maple
- 1.6mm Steel (RIM1410B/1410S)
- CL-05
- 10
- SST-5042
- SR-018
- S-022N

Signature Series

Imagine being able to capture the elusive sound of your drumming idol. Pearl's extensive line of Signature Series Snares gives you an opportunity to own a snare developed with input from the pros. We offer snares from some of the world's greatest players, and they're all available at your Pearl Dealer.



Jimmy DeGrasso

Jimmy has laid the foundation for such hard rock acts as Alice Cooper, Ozzy Osbourne, Suicidal Tendencies and most notably, the multi-platinum Megadeth. Jimmy's Signature Snare Drum is a 14"x 5.5" hammered brass snare drum with gold-plated hardware, ideal for loud, amplified music. This striking drum is sure to catch the eyes and ears of all drummers.



- JD1455** [new]
 Size (Dia. X Depth) : 14" X 5.5"
 Shell : 1mm Beaded, Hammered Brass
 Hoops : SuperHoop II / Gold Plated (SHG1410 / 1410SG)
 Lugs : CL-55G
 Rods : 10
 Tension Rods : SST-5052 Stainless Steel Tension Rod
 Strainer : SR-017G
 Snares : S-14200 Ultra-Sound "D" Type



Mike Mangini

Mike is recognized as one of the fastest drummers alive and actually set the world record for a single stroke roll with 1,247 strokes in 60 seconds. He has recorded and toured with such acts as Steve Vai, Extreme and Annihilator. Mike serves as a full time professor at Berklee, so it made perfect sense for his Signature Snare to be based on the ancient architectural phenomenon that is the Golden Ratio. This snare drum is a modern marvel!



- MM1062** [new]
 Size (Dia. X Depth) : 10" X 6.2"
 Shell : 6 even ply Birch
 Hoops : SuperHoop II (SH1006 / 1006S) w/OptiMount (OPTA-0665)
 Lugs : STL-65
 Rods : 6
 Tension Rods : SST-5047 Stainless Steel Tension Rod
 Strainer : SR-017
 Snares : S-032N



Morgan Rose

When rocking with his band Sevendust, Morgan needs his drum to be loud, powerful and full of attitude, so his mean 14"x5" Steel drum has all the projection to cut through huge speaker stacks and subwoofers. This snare features a nasty green metallic finish with glow-in-the-dark "Alien" graphic that can't be missed. The Morgan Rose Signature Snare Drum is a force to be reckoned with.



- MR1450** [new]
 Size (Dia. X Depth) : 14" X 5"
 Shell : 1 mm Steel
 Hoops : SuperHoop II (SH1410B / 1410S)
 Lugs : CL-55
 Rods : 10
 Tension Rods : SST-5047 Stainless Steel Tension Rod
 Strainer : SR-017
 Snares : SN-1442I Ultra-Sound "I" Type, 42 Strands



Vinnie Paul

Vinnie Paul is without question one of the most recognizable drummers in the World. The original "Cowboy from Hell". His work with Pantera and Damageplan is as unmistakable as his Signature snare drum. Designed for crushing volume and extreme projection with an enormous 8" depth and 6 ply Maple construction, this snare exudes rock'n'roll swagger with its faux snakeskin and dangerous spiked lugs. This snare has bite!



- VP1480**
 Size (Dia. X Depth) : 14" X 8"
 Shell : 6 Ply Maple
 Hoops : SuperHoop II (SH1410B / 1410S)
 Lugs : TB-80VP
 Rods : 10
 Tension Rods : SST-5038 Stainless Steel Tension Rod
 Strainer : SR-017
 Snares : SN-022N



Joey Jordison

Joey Jordison has a reputation as one of the most influential, respected and successful drummers in the world today. Playing stadiums worldwide with Slipknot, Joey needed a snare drum with a higher pitch, monster bite, and this 13"x6.5" 1mm Steel shell Power Piccolo delivers the rage and power you'd expect from Joey.



- JJ1365**
 Size (Dia. X Depth) : 13" X 6.5"
 Shell : Steel/Black Finish
 Hoops : SuperHoop II / Black Finish (SH1308B / 1308S)
 Lugs : CL-65B
 Rods : 8
 Tension Rods : SST-5047 Stainless Steel Tension Rod
 Strainer : SR-017B
 Snares : SN-029N



Virgil Donati

Virgil has pushed back the barriers of playing drums with his innovative use of the instrument, complex rhythms, creative phrasing and extreme speed, and naturally he has taken great care to design a unique snare drum. Using a 8 ply blended shell, rounded bearing edges and a totally flat snare bed, Virgil's signature snare drum is as state-of-the-art as his playing.



- VG1450**
 Size (Dia. X Depth) : 14" X 5"
 Shell : 8 Ply (Outer: 4 ply Maple / Inner: 4 Ply Birch)
 Hoops : MasterCast (DC1410 / DC1410S)
 Lugs : TB-50
 Rods : 10
 Tension Rods : SST-5042 Stainless Steel Tension Rod
 Strainer : SR-017
 Snares : SN-022N
 Color : #188 Smoke Fade

Ultra-Sound Snare Wires US.PAT.7202405

Pearl's UltraSound snares feature patented Graduated Tension wires with strategically positioned looser and tighter wires. The looser wires respond to the lightest touch while the tighter wires maintain head contact during the loudest playing. Combined, Graduated Tension wires extend the dynamic range of UltraSound snares far beyond that of standard snares. The SN-1420C features "C" shaped end plates with looser tension wires in the center for outstanding tracking and response, and is ideal for rock music and metal snare drums. The SN-1420D features "D" shaped end plates with tighter tension wires in the center for superb sensitivity, and is ideal for classical music and wood snare drums. The SN-1420I has even tension snare wires for those who want traditional snare dynamics, but with the benefits of the UltraSound's non-plated rust proof snare wires and ultra-thin, low mass 0.6mm Phosphor Bronze end plates for ultra quick response. The end plates have three mounting options: tunnels and holes for cord mounting, and slots for straps.

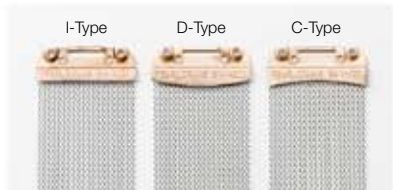



Ian Paice

Deep Purple's legendary drummer designed this snare drum to have classic looks and classic sound with modern technology. The 6.5" steel shell will give you a big rock sound, and the locking nuts will help your drum to "stay tuned all night".



IP1465

- Size (Dia. X Depth) : 14" X 6.5"
- Shell : Beaded Sheet
- Hoops : SuperHoop II (SH1410 / 1410S)
- Lugs : TB-65
- Rods : 10
- Tension Rods : SST-5042 Stainless Steel Tension Rod
- Strainer : SR-017
- Snares : S-022N



Tico Torres

After decades of international success with Bon Jovi, Tico Torres worked with the Pearl design team and chose a cast aluminium shell to achieve a sound that has the warmth of a wood drum with the bite of a metal drum.



TR1465

- Size (Dia. X Depth) : 14" X 6.5"
- Shell : 3mm Cast Aluminum w / Reinforcement
- Hoops : MasterCast (DCS1410 / DC1410S)
- Lugs : CL-65
- Rods : 10
- Tension Rods : SST-5042 Stainless Steel Tension Rod
- Strainer : SR-010
- Snares : S-025



Eric Singer

Eric has been rocking crowds around the world with mega band Kiss, and needed a drum that could match the intensity of their incredible live shows. His signature drum has an extra thick 10 ply Maple shell for impressive projection and outstanding power.



ES1465

- Size (Dia. X Depth) : 14" X 6.5"
- Shell : 10 Ply Maple
- Air Vents : 3
- Hoops : MasterCast (DCS1410 / DC1410S)
- Lugs : CL-65
- Rods : 10
- Tension Rods : SST-5047 Stainless Steel Tension Rod
- Strainer : SR-017
- Snares : S-022N
- Color : #160 Silver Sparkle



Dennis Chambers

As one of the world's most respected International session musicians and clinicians, Dennis' signature snare drum has outstanding sound and tonal dynamics. This top specification drum includes a wide range of features to help you achieve the perfect sound.



DC1465

- Size (Dia. X Depth) : 14" X 6.5"
- Shell : 4 Ply Maple
- Reinforcement : w/4 ply Maple Reinforcement Rings
- Hoops : MasterCast (DCS1410 / DC1410SG)
- Lugs : CL-100
- Rods : 10
- Tension Rods : SST-5047 Stainless Steel Tension Rod
- Strainer : 4-Way Adjustable / SR-020 on both sides
- Snares : S-030N
- Color : #136 Opal White



Omar Hakim

Having played the drums for Sting, Madonna and David Bowie, to name but a few, Omar was looking for a unique sound in designing his signature snare drum. The 13" x 5" shell has a power piccolo sound while the Mahogany helps to produce the perfect blend of sonic power, projection and tonal color.



OH1350

- Size (Dia. X Depth) : 13" X 5"
- Shell : 6 Ply African Mahogany
- Hoops : SuperHoop II (SH1308B / 1308S)
- Lugs : CL-55
- Rods : 8
- Tension Rods : SST-5047 Stainless Steel Tension Rod
- Strainer : SR-015
- Snares : SN-029N
- Color : #140 Natural Mahogany



Chad Smith

Explosive, versatile and funky...these words not only describe Chad's playing with the Red Hot Chili Peppers, but also describe the sound of his awesome signature snare drum. One of the best selling drums in Pearl's arsenal, the Chad Smith snare drum will help bring your groove to the next level.



CS1450

- Size (Dia. X Depth) : 14" X 5"
- Shell : Steel, Black Nickel Plated
- Hoops : SuperHoop II (SH1410B / 1410S)
- Lugs : CL-55
- Rods : 10
- Tension Rods : SST-5047 Stainless Steel Tension Rod
- Strainer : SR-015
- Snares : SN-022

SR-1000 Glide-Lock Strainer

US.PAT.7220905/7301087

Pearl's SR-1000 Glide-Lock strainer addresses two age-old strainer problems that have plagued drummers for years: the throw-off lever flipping off and the tension knob loosening while playing. The SR-1000's patented throw-off lever features a Positive Lock system that locks in the ON position and completely removes the possibility of the snares turning off no matter how hard you play. Using patented low-friction technology the lever has a smooth gliding action to raise and lower the snares with ultra quiet precision. The patent pending tension knob also locks and both the throw-off and butt plate can be removed from the shell with the snares attached to allow quick and easy bottom head changes.

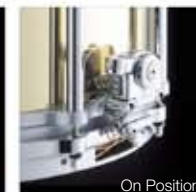

PEARL ADVANCED HARDWARE SYSTEMS

PEARL HARDWARE, THE CHOICE OF PROFESSIONALS

Pearl's Advanced Hardware Systems introduces a line of professional grade hardware that will forever alter the way that you look at hardware. Hardware strengthened with innovations like our double strut legs to prevent lateral movement and hidden nylon bushings within the tubes to prevent metal-to-metal contact and the inherent squeaks that arise from it. Oversized non-slip rubber feet provide greater surface adhesion to keep everything firmly planted. Our robust die-cast pipe joints provide super human clamping power via our UltraGrip wingnuts to keep everything exactly where you want it. Our award-winning BC-2000 boom stand provides mounting options never before attainable. Each piece is engineered to function above and beyond traditional hardware. That's why we call it Advanced.

▶▶▶▶ PEARL DRUM PEDALS AND HARDWARE

ADVANCED
HARDWARE SYSTEMS

| 2000 | 1000 | 900 | SERIES



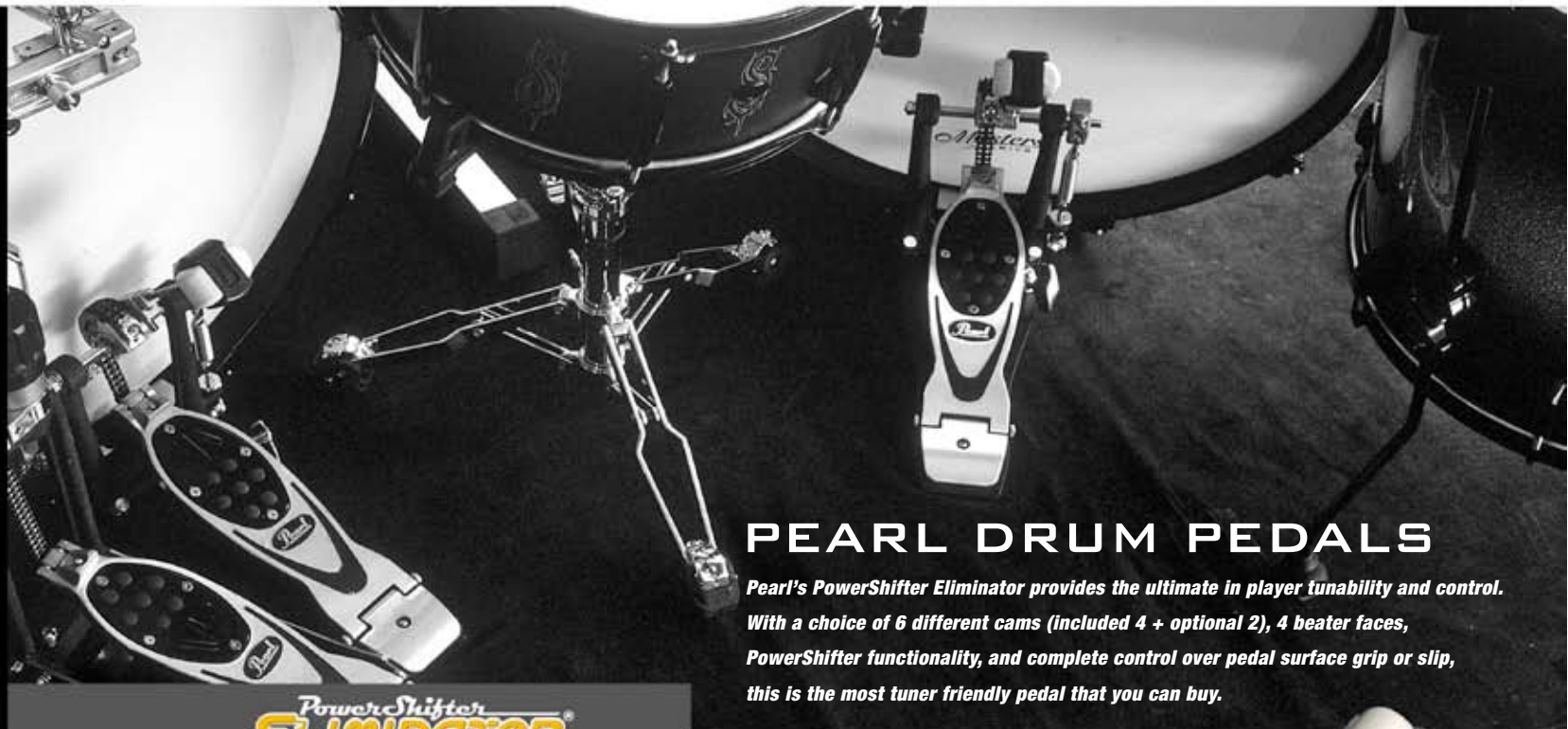

PEARL DRUM PEDALS

Pearl's PowerShifter Eliminator provides the ultimate in player tunability and control. With a choice of 6 different cams (included 4 + optional 2), 4 beater faces, PowerShifter functionality, and complete control over pedal surface grip or slip, this is the most tuner friendly pedal that you can buy.

**PowerShifter
ELIMINATOR**

| P-2000 | SERIES

INTERCHANGEABLE CAM SYSTEM

US.PAT.6172291

Our exclusive Cam System provides six (included 4 + optional 2) interchangeable color coded cams allowing you to quickly change the power and feel of the pedal to suit your individual playing needs. Changing from cam to cam is as simple as pushing the release button and snapping another cam in place.

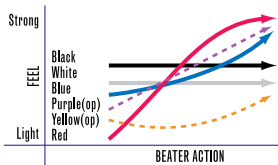

BLACK LINEAR ACTION CAM



This is Pearl's original "perfect circle" Cam design. It offers superior power and a very natural, perfectly balanced action and smooth feel.

WHITE OVERSIZED LINEAR CAM



The White Cam is a slightly over sized "perfect circle" Cam. It offers a very natural, smooth action, with great power and balance, with a slightly lighter pedal feel.

BLUE PROGRESSIVE CAM



This is the very popular "off-center" axis type cam design. It offers a light feel in the beginning that accelerates with speed and power upon impact.

RED RADICAL PROGRESSIVE CAM



The Red Cam features an extreme "off-center" axis design. The action is similar to the Blue Cam but with a lighter feel at the beginning of the stroke.

OPTION CAMS

PURPLE AGGRESSIVE ACTION CAM



The Purple cam provides aggressive acceleration for huge power and response, second only to the Red cam.

YELLOW INVERSE ACTION CAM



The Yellow cam provides a slight inverse action. When maximum power is required, this is the cam of choice.

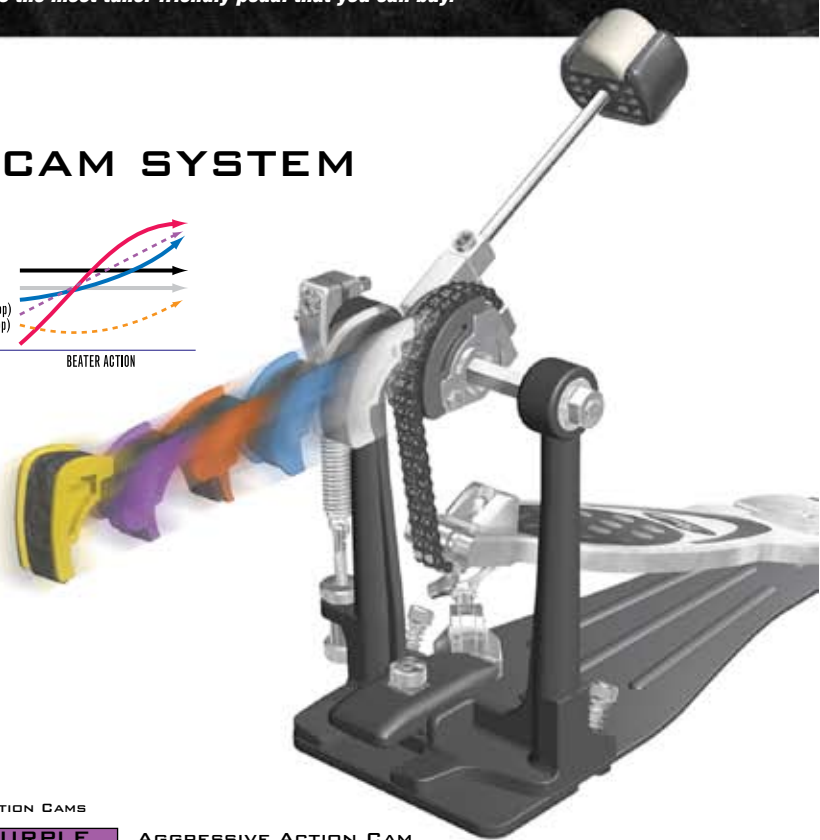

**POWERSHIFTER
ELIMINATOR
DRUM PEDALS
P-2000
SERIES**

CHAIN DRIVE

Pearl's sprocket-less double chain drive provides super smooth action with powerful and precise feel. Since there are no teeth, the "grinding" noise common with most chain drive pedals is eliminated making the Eliminator perfect for studio work.



P-2000C

BELT DRIVE

Our Belt Drive provides a very comfortable, natural feel similar to a direct drive system. We use an extremely strong, highly durable drive belt, instead of a normal rubber strap, to provide maximum durability, strength, and stretch resistance.



P-2000B



**DOUBLE PEDAL COMPLETE
(Right-Footed)
P-2002C**

**DOUBLE PEDAL CONVERSION KIT
(Right-Footed)
P-2001C**

**DOUBLE PEDAL COMPLETE
(Left-Footed)
P-2002CL**



**DOUBLE PEDAL COMPLETE
(Right-Footed)
P-2002B**

**DOUBLE PEDAL CONVERSION KIT
(Right-Footed)
P-2001B**

**DOUBLE PEDAL COMPLETE
(Left-Footed)
P-2002BL**

PEARL DRUM PEDALS

POWERSHIFTER

US.PAT.5574237

Our revolutionary PowerShifter function provides 3 positions to fine tune the power and feel of the pedal. By moving the footboard forward or back you change the chain or belt drive angle, thus changing the leverage to create a light, normal or strong feel.



INDEPENDENT TRACTION GRIPS

Power Shifter Eliminator's Traction Plate footboard insert allows you to remove and reconfigure each individual traction grip to suit your exact playing requirements. From maximum grip to full slide, and every option in between, the choice is yours. The Traction Plate also reverses to focus the slide or grip surfaces to either the toe or heel of the pedal.

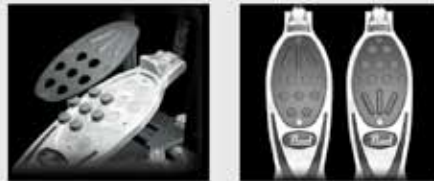

ZERO PLAY HINGE

Our stainless steel hinge is manufactured with incredibly precise tolerances to prevent play between the footboard and heel yet provides maximum freedom of motion for blazing speed. (US.PAT.7179978)

FOOTBOARD ANGLE ADJUSTMENT

Footboard angle is easily adjusted and completely independent from beater angle allowing you to further fine tune the feel and action of your pedal.

ROLLER CAM HOOP CLAMP

Our Roller Cam Hoop Clamp multiplies each turn of the adjustment knob to speed the process of attaching the pedal to the hoop. It fits an extremely wide range of hoop thicknesses and offers the smoothest, most secure grip possible. (US.PAT.5726370)



WIDE TENSION-RANGE SPRING

Our counter spring has been designed to perfectly compliment the weight and balance of the footboard and beater assembly. It also offers a much wider range of adjustability allowing you to fine tune the pedal tension to suit your playing style.

UNI-PRESSURE SPRING CLAMP

Our Uni-Pressure Spring Clamp System grips a full 360 degrees and allows infinite beater angle adjustments. Featuring a unique Floating Spring Pendulum design that is perfectly centered on the clamp, this system offers full precision bearing movement for unmatched smoothness.

**POWERSHIFTER
DRUM PEDALS
P-900**

The P-900 is jam packed with high-end features such as a linear round cam, single chain drive, patented PowerShifter, infinitely adjustable beater angle, and PowerPlate.



P-900

**DRUM PEDALS
P-120
SERIES**



P-120P



P-120



**DOUBLE PEDAL COMPLETE
(Right-Footed)
P-122TW**

**DOUBLE PEDAL CONVERSION KIT
(Right-Footed)
P-121TW**

**DOUBLE PEDAL COMPLETE
(Left-Footed)
P-122TWL**

QUADBEATER

Our QuadBeater provides four different beater surfaces, each with its own distinct sound. You can choose from 2 hard plastic surfaces or 2 felt surfaces and either pinpoint or line contact with the head.

DOUBEAT

The DuoBeat Beater offers two different faces, plastic and felt, adding great versatility of sound over single surface beaters. It's like getting two beaters for the price of one.

**QUADBEATER
(US.PAT.5610351)**



DOUBEAT



**BEATER WEIGHT
BW-100 (US.PAT.7122730)**

The BW-100 Beater Weight features a main body (10.4 gram) and two removable add-on weights : Black (7.2 grams) and Silver (5.8 grams) that can be added or subtracted to achieve perfect feel and power.



**PEDAL STABILIZER
PS-85**

PEARL DRUM PEDALS

	POWERSHIFTER ELIMINATOR P-2000 SERIES				P-900	P-120		
MODEL	P-2000C	P-2002C	P-2000B	P-2002B	P-900	P-120P	P-122TW	P-120
DRIVE	Double Chain		Belt		Single Chain	Single Chain		
CAM	Interchangeable Cam				Aluminum Die-Cast Wheel	Aluminum Die-Cast Wheel		
POWERSHIFTER	•	•	•	•	•	•	•	--
FOOTBOARD	TractionPlate & TractionGrip							
FOOTBOARD ANGLE	3 Positions							
BEATER	QUAD BEATER				DUO BEAT	DUO BEAT		
BEATER ANGLE	Uni-Pressure Spring Clamp				Beater Angle Cam	Beater Angle Cam		
SPRING ROLLER	Bearing				FrictionLess Roller	FrictionLess Roller		
HOOP CLAMP	Roller Cam Hoop Clamp					Roller Cam Hoop Clamp		

**P-2000 SERIES
come standard
with Custom Carry bags**



HI-HAT STANDS



POSILINK TWIN CAM DRIVE SYSTEM w/ INTERCHANGEABLE CAMS (US.PAT.6399866)

Our exclusive PosiLink drive system features twin double chain driven cams one of which accepts your choice of 6 interchangeable cam profiles (4 included and 2 optional) so you can customize the response from mild to wild. If you want a traditional direct drive feel, use one of the two round cam profiles. But if you dare, try the four eccentric cam profiles with varying degrees of offset for accelerated feel that you can't get from any other hi-hat on the planet!



POWERSHIFTER

PowerShifter allows the player to quickly shift the footboard to one of three playing positions. This changes the angle of the pull chain which in turn changes the overall feel of the hi-hat reaction.

TRACTION PLATE FOOTBOARD

Like all Eliminators, the pedal has removable traction grip inserts that can be adjusted or removed to tailor the amount of grip or slip. The plate is even reversible for more choices.

VARISET FOOTBOARD ANGLE ADJUSTMENT

The VariSet cam is infinitely adjustable to allow micro-fine adjustment of the footboard angle for optimum comfort and speed. Footboard angle can be further adjusted by moving the chain to three positions on the pedal cam.

1. SUPERGRIP CLUTCH

[SGC-300P] (PAT.PEND)

The H-2000 features our SuperGrip Clutch. This clutch system uses a larger surface area with 360 degrees of grip that provides vice like clamping force for super grip.

2. HI-HAT CUP (US.PAT.7078606)

Our patented seat cup features a hinged platform for outstanding stability and consistent hi-hat sound.

3. PRECISION SPRING TENSION DIAL

Our precision Spring Tension Dial features a positive click stop design for precise control over hi-hat tension.



No other part of your kit takes the punishment that your Hi-hat takes. It has to be fast, responsive and strong to keep the groove moving. Pearl offers a wide range of Hi-hats to compliment your playing style from our light-weight, easy to carry H-72W to our state-of-the-art Eliminator, that like our Eliminator pedals, features our patented interchangeable cam system for customized feel to allow the pedal to become an extension of yourself.



ADVANCED
HARDWARE SYSTEMS



ELIMINATOR
HI-HAT STAND
H-2000



ELIMINATOR
REMOTE HI-HAT
RH-2000

PowerShifter
ELIMINATOR

4. SWIVELING LEGS

Our swivelling legs allow perfect placement by themselves or with multi-pedal set-ups. (*except H-72W)

5. CONVERTIBLE SPIKE / RUBBER TIPS (PAT.PEND)

The extra large non-slip rubber feet have a push button activated spike that pops out for non-slip grip on carpet or rubber surface. A second button returns it instantly to its recessed position.

6. NEW FOOTBOARD DOCKING STATION

The H-2000 now features a patent pending footboard attachment system and docking station for improved stability and security during transport. The footboard is attached via a tongue and groove-type locking system that holds the stand rigidly at a perfect 90 degree angle for maximum stability. The integrated docking station clamps the footboard safely and securely during transport for maximum protection of the chain and cam system.

7. STANDARD CLUTCH (CL-300)

Our CL-300 clutch used on H-1000 series hi-hats features our Triple-Lock gripper system for zero slippage.

8. FOOTBOARD ANGLE ADJUSTMENT

The H-1000's exclusive threaded foot board connector allows the footboard to be infinitely adjustable for maximum speed and comfort.

9. ROLLER PULLEY SYSTEM (US.PAT.5018426)

The roller system uses a pulley to provide incredible cymbal force with minimal pedal exertion.



**HI-HAT ACCESSORIES
CLOSED HAT
CLH-1000**

The CLH-1000 facilitates the placement of closed hi-hats anywhere on your kit. It includes a boom arm, infinitely adjustable Uni-Lock tilter, pivot-action seat cup and ergonomic UltraGrip wing nuts/ wing bolts.



HI-HAT ATTACHMENT HA-100

The HA-100 positions your hi-hat next to your bass pedal in double bass set-ups for super quick transitions between pedals.

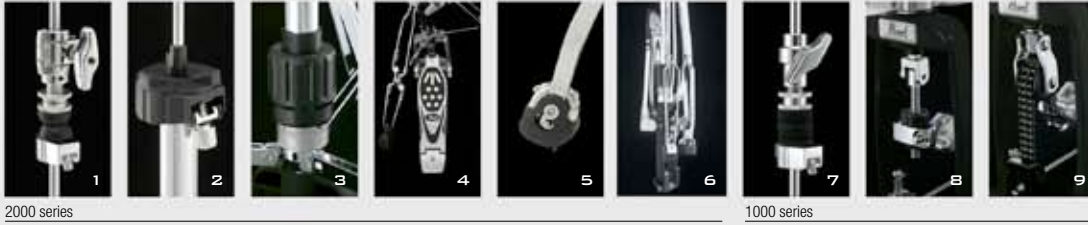

2000 series

1000 series



HI-HAT STANDS

MODEL	ELIMINATOR SERIES		1000 SERIES		900 SERIES	70 SERIES
	H-2000	RH-2000	H-1000	H-1000K	H-900	H-72W
DRIVE	PosiLink Twin Cam Drive Interchangeable Cams		Direct Pull	Roller Pulley System	Direct Pull	Direct Pull
POWERSHIFTER	•	•	---	---	---	---
FOOTBOARD	TractionPlate & TractionGrip		TractionPlate & TractionGrip			
FOOTBOARD ANGLE	VariSet Footboard Angle Adjustment		Footboard Angle Adjustment			
CLUTCH	SuperGrip Clutch w/ Lock Nut	Drop Clutch	Standard Clutch w/ Lock Nut		Standard Clutch	Standard Clutch
SPRING TENSION ADJUSTMENT	•	•	•	•	•	---
SWIVELING LEGS	•	•	•	•	•	---
LEG TIPS	Push Button Convertible (Spike / Rubber)		Reversible (Spike / Rubber)		Rubber	Rubber

Hundreds of Snare,
One Snare Stand

ALL FIT SNARE STAND
S-2000

ALL FIT SNARE ARMS

The all-fit snare arms found on our S-2000 allows individual adjustment of the snare arms to fit drums from 10" to 16". This unique feature also allows the offset placement of your drum for total positioning control. The patented (US.PAT.6710236) Air Suspension rubber tips securely cradle your prized snares without applying unnecessary pressure to the shell. This offers security for your snare without compromising resonance and sustain.

GYROLOCK TILTING SYSTEM

The GyroLock tilter allows complete tilt control over your snare angle. The Ultra-Grip wingnuts make adjustments quick and sure.

PUSH BUTTON CONVERTIBLE RUBBER TIP

The S-2000 features convertible rubber/spike tipped feet that allow your stand to adapt to any playing surface. A push of a button activates spike tips that provide maximum bite on carpeted surfaces. A second button returns them to their recessed position. (PAT.PEND)



Our Snare Stands are available with a wide range of options and features. From our lightweight easy to carry S-70W for the local gig to our flagship S-2000, all Pearl snare stands will cradle your prized snares perfectly and dependably for years to come.



S-2000

SNARE STANDS



S-1000



S-1000D



S-900



S-70W

SNARE STANDS

MODEL	S-2000	S-1000	S-1000D	S-900	S-70W
HEIGHT(mm)	450 - 630mm		360 - 540mm	460 - 650mm	435 - 650mm
SIZE	10" - 16"	12" - 14"		13", 14"	13", 14"
TILTER	GyroLock			Uni-Lock	Gear System
ARM TIPS	Suspension Rubber Tips			Rubber Tips	Rubber Tips
LEGS	SureStrut / Double Braced Legs			Double Braced Legs	Double Braced Legs
LEG TIPS	Push Button Convertible Rubber Tips	Rubber Tips		Rubber Tips	Rubber Tips

TILTING SYSTEM

The S-900 features our Uni-Lock infinitely adjustable tilter for pin-point drum placement.



SBA-1 SNARE BASKET ADAPTER

The SBA-1 attaches quickly to the tips of the S-800W snare stand to accept a broader range of snares including Sopranos and Effects Snare to 10". Rubber inserts prevent the snare from slipping. Sold in packs of 3.



DRUM THRONES

If you can't sit comfortably you can't play your best. That's why Pearl thrones like our Roadster Series feature ergonomic accents that promote good posture and comfort during extended playing. Innovative features such as the reversible backrest, and two-zone cushion on the D-2000BR throne and the shock absorber cushion on the D-1000SP that minimizes shock to your spine to fend off fatigue, are just some of the comfort features you'll find on Pearl thrones.



ROADSTER THRONE
D-2000



ROADSTER THRONE
D-2000BR



ROADSTER THRONE
<SHORT TYPE>
D-1000S



ROADSTER THRONE
D-1000



ROADSTER THRONE
<VELVET>
D-1000C



ROADSTER THRONE
<SUSPENSION TYPE>
D-1000SP



D-900



D-80



D-75



D-70W

Our ergonomic seat provides two unique seating options. Firm padding with a smooth channel in the center can be used with the channel facing forward or backward to suit your personal preference. (D-2000BR / D-2000)

The quick release height adjustment clamp features a fine tuner for perfect height settings. (D-2000BR / D-2000 / D-1000 / D-1000S / D-1000C)

The built-in shock absorber minimizes shock to your spine to maximize comfort. (D-1000SP)

The spring tension is quickly and easily adjustable for your preferred level of comfort. (D-1000SP)

The height collar features vice-like clamping action for slip-proof dependability. (D-75)



DRUM THRONES

MODEL	D-2000BR	D-2000	D-1000	D-1000S	D-1000C	D-1000SP	D-900	D-80	D-75	D-70W
HEIGHT(mm)	490 - 650mm		470 - 630mm	425 - 580mm	470 - 630mm	500 - 660mm	460 - 660mm	500 - 660mm	430 - 680mm	430 - 650mm
SEAT	PVC		PVC	Velvet	PVC	PVC / Memory Foam	Saddle / PVC	PVC		
LEGS	SureStrut / 4-Double Braced Legs		SureStrut / 3-Double Braced Legs			SureStrut / 3-Double Braced Legs	3-Double Braced Legs			
	Back Support			Short Type		Build-in Shock Absorber				



CYMBAL STANDS

Pearl cymbal and boom stands are the choice of the working drummer. Solid and strong with thick chrome finishes that ensure a long life and dependable service, Pearl Advanced Hardware Systems stands are available with a wide range of options to fit your every need. From the studio to the stage, you can count on Pearl hardware.

WINGLOC (US.PAT. 6884015)

Our WingLoc quick release wing nut makes old fashioned wing nuts a bleak memory with its snap on, snap off ease of use. Whereas traditional wing nuts have to be manually unscrewed or screwed tighter, the WingLoc just slides onto a cymbal holder and snaps together to hold the cymbal firmly in a matter of seconds.

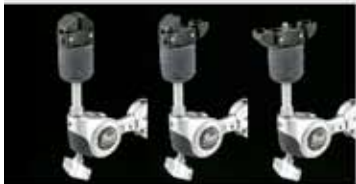

Our patented Reversible Seat Cup (US. PAT. 6940006) can be set to Float like a traditional seat cup or it can be reversed and Locked for 100% rattle-free performance for recording applications.



GYROLOCK & UNI-LOCK
GyroLock allows a full 360 degree range of motion for the fastest, easiest, and most precise setting of cymbals and toms. See it on our award-winning and revolutionary BC-2000 boom stand. Spin it. Lock it. Play it!
Uni-Lock tilters provide infinite positioning options and lock securely with a twist of our ergonomic UltraGrip wing bolts.

SETTING

The BC-2000 offers so many diverse mounting possibilities. With a built-in knurled post, it's perfect for adding cowbells or percussion effects. Add on some additional TL-2000 GyroLock Tilters and mount multiple cymbals on the same boom stand.

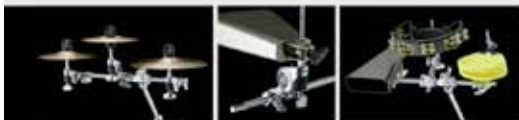

DETACHABLE COUNTER WEIGHT

The detachable counterweight ensures perfect balance and stability.

DIE-CAST JOINT

Our die cast pipe joints provide unrelenting grip for solid and dependable positioning while the hidden nylon bushings inside the tubes prevent metal-to-metal contact for rattle free and quiet performance.

SURESTRUT & STOPLOCK

The BC-2000 also features our double strut legs to prevent lateral movement and positive stop memory locks for repeatable height settings.

OVERSIZED NON-SLIP RUBBER FEET

The over-sized non-slip rubber feet are the foundation of the BC-2000's stability. They provide sure footing and absorb unwanted overtones.

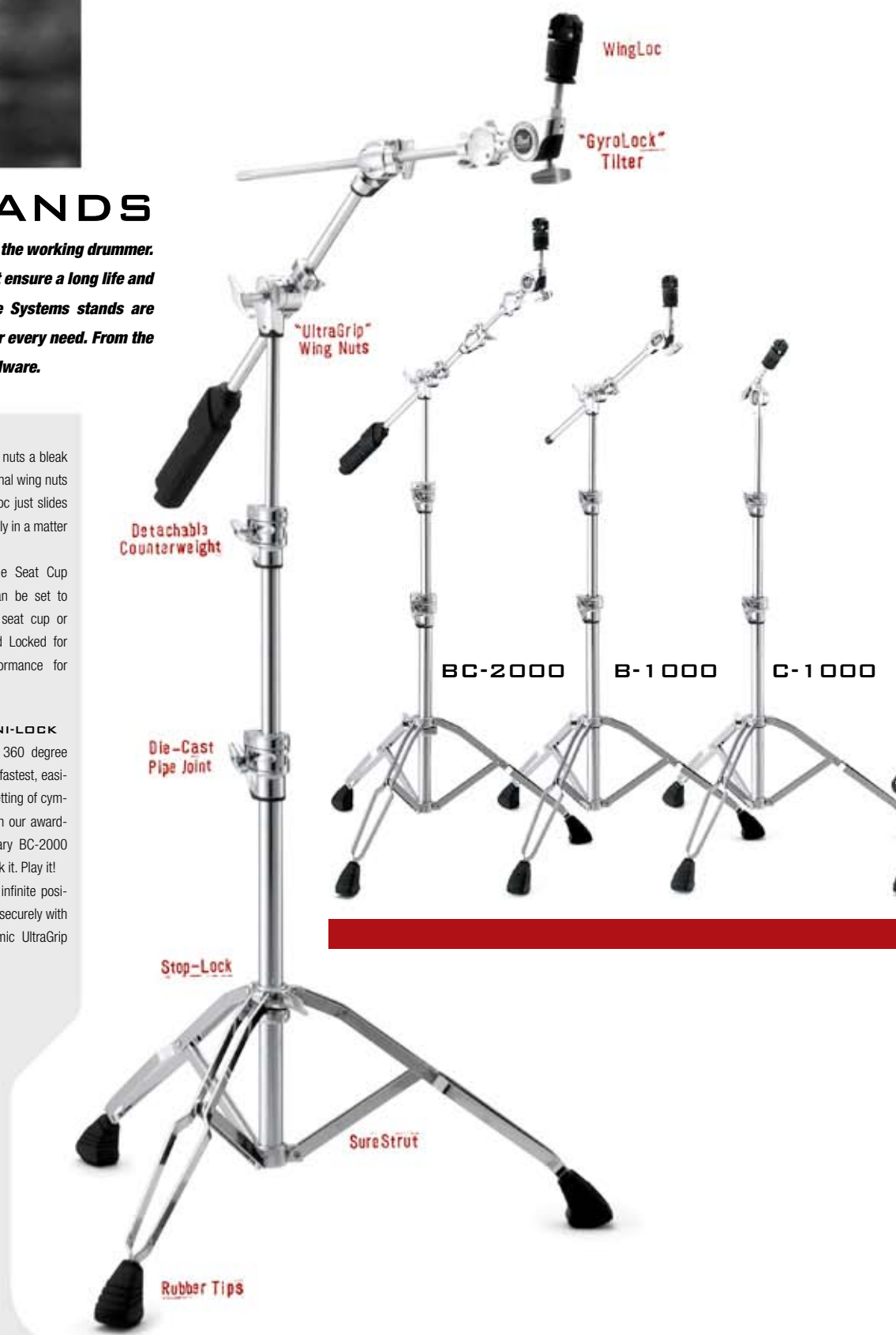

2000 series

900 series

Plastic Tip for Noise Reduction

Die-Cast Joint w/StopLock

Detachable Counter-Weight

SureStruts

StopLock

Uni-Lock Tilter

Die-Cast Joint

StopLock

BC-100S

CONVERTIBLE FLAT BASE STAND

Pearl's new BC-100S Convertible Flat Base Stand is a lightweight boom cymbal stand that features an exclusive low profile flush-base design that is convertible into a traditional tripod base. The BC-100S features a gear tilter and is specially designed to be lightweight and highly portable.



CYMBAL STANDS

	2000 SERIES		1000 SERIES		900 SERIES			70 SERIES		100 SERIES
MODEL	BC-2000	B-1000	C-1000	BC-900	B-900	C-900	B-70W	C-70W	BC-100S	
CYMBAL TILTER	WingLoc			Plastic Wing Nut			Wing Nut, Vinyl Tube, Felt		Wing Nut, Vinyl Tube, Felt	
	Reversible Cup Washer w/ O-Ring			Plastic Cymbal Cup			Steel Washer		Steel Washer	
	GyroLock		Uni-Lock	Uni-Lock			Gear System		Gear System	
PIPE JOINT	Die-cast Joint w/ Stop Lock		Die-cast Joint		Die-Cast Joint			Nylon Bushing Joint	Nylon Bushing Joint	
LEGS	SureStrut / Double Braced Legs			Double Braced Legs			Double Braced Legs		Single Braced Legs	
PIPES	28.6 / 22.2 / 15.9 mm			28.6 / 22.2 / 15.9 mm			22.2 / 19.1 / 15.9 mm		19.1/15.9 mm	

CYMBAL HOLDERS

MODEL	CH-2000	CH-2000S	CH-1000	CH-80	CH-70
DIAMETER	22.2mm			15.9 - 28.6mm	

CYMBAL STACKERS



Cymbal Stacker with dual angle tilters allow the mounting of multiple cymbals on the same stand. Cool angles and lots of options are possible for a whole new world of cymbal placement.

Fits B-800W, C-800W, BC-800W, C-70W, B-70W, CH-80



DRUM RACKS

Pearl's **ICON Series** are the gold standard for drum racks. Its patented square aluminum tubing allows clamps to hold without turning or sliding for ultimate stability and each section is independently height adjustable. Our clamps feature high-strength die cast construction and hinged quick release jaws for fast set up and tear down. **ICON** racks are available with straight or curved tubes in front and three-sided versions. Expansion kits are also available with straight and curved tubes for customized set ups.



ICON 3-SIDED RACK
DR-503
w/ PCX-100(4), PCL-100(2)



ICON FRONT RACK
DR-501
w/ PCX-100(2), PCL-100



ICON FRONT RACK
DR-501C
Curved Bar, w/ PCX-100(2), PCL-100



3-SIDED RACK
DR-80
(*also available DR-008 Expansion Bar)



ICON EXPANSION BAR
DR-501E



ICON EXPANSION BAR
DR-501CE



PIPE CLAMP
PCX-100
Clamping System
w/Adjustable Jaw
for ICON/110/210

PIPE CLAMP
PCX-200
Tilting Clamp System
w/Adjustable Jaw

PIPE CLAMP
PC-8
fits 7/8" tubes,
for DR-80

ICON 6" MINI-EXPANSION BAR
RJ-50

PIPE CLAMP FOR LEG
PCL-100
Fits All ICON Rack Leg Posts

ADAPTERS



AX-20
2 Clamps
fits 5/8" ~ 1-1/8"



AX-25
2 Revolving Clamps
fits 1/2" ~ 1-1/8"



AX-25L
2 Revolving Clamps
fits 1/2" ~ 1-1/8"



AX-28
In-Line & Revolving Clamps
fits 5/8" ~ 1-1/8" & 1/2" ~ 1-1/8"



AX-38
fits 3/8" ~ 1-1/4"
3 Adjustable Clamps



UNIVERSAL CLAMP
UX-80 13" Long Tube
UX-80S 4" Long Tube





**TOM STANDS
TOM HOLDERS**

*Our Advanced Hardware Systems
TH-2000 and TH-1000
Tom holders provide positioning
capabilities never before available.
Large non-slip rubber feet and
No rattle tubes make our
tom stands the studio kings.*



COMBINATION STANDS

GYROLOCK	UNI-LOCK
TC-2000	TC-1000
w/ TH-2000S, CH-2000S	w/ TH-1000S, CH-1000S

DOUBLE TOM STANDS

GEAR	GYROLOCK	UNI-LOCK	GEAR
TC-800W	TC-2000	TC-1000	TC-800W
w/ TH-88S, CH-80	w/ TH-2000S(2)	w/ TH-1000S(2)	w/ TH-88S(2)



TH-2000I

TH-2000S

TH-1000I

TH-1000S

TH-900I

TH-900S

TH-88I

TH-88S

TOM HOLDERS

**GYROLOCK
2000 SERIES**

- TH-2000
- TH-2000I
- TH-2000S

**UNI-LOCK
1000 SERIES**

- TH-1000
- TH-1000I
- TH-1000S

**UNI-LOCK
900 SERIES**

-
- TH-900I
- TH-900S

**GEAR
88 SERIES**

- TH-88
- TH-88I
- TH-88S



HEIGHT EXTENDERS

TX-100
13" Long Tube

COWBELL HOLDER

CA-100

Hoop Mounted, Adjustable L-Arm

75H

Hoop Mounted



COWBELL HOLDER

75X

7/8" Dia Tube

PPS-30

3/8" Post

PPS-37

Multi-Angle "L" Arm



GYROLOCK & UNI-LOCK

The TH-2000 utilizes our GyroLock tilter with infinite 360 degree range of movement. The TH-1000 and TH-900 feature our dependable Uni-Lock tilter with 180 degree infinitely adjustable range of motion.

Pearl Percussion



Andres Bermudez
A.B. Tribal Drums



Andy Farag
Umphreys McGee



Anthony Carrillo
Eddie Palmieri



Archie Pena
Shakira



Bobby Allende
Ocho Y Mas



Camilo Moreno
B-Side Players



Camilo Quinones
B-Side Players



Carlito Soto
Willie Colon



Carmelo Torres
Del Castillo



Cesar Carvajal



Cesar Espinoza
Orquesta Tabaco Y Ron



Chino Bolanos
Independent



Count M'Buto
Derek Trucks



Curtis Rodriguez
Marc Anthony



Daniel Antonetti
New York Independent



Dimas Sanchez
Rico Monaco,
Iba A Se



Ernesto Diaz
Berklee Faculty



Etienne Fuentes
Chayanne



Fausto Cuevas
Stevie Wonder



Francisco Aguabella
L.A. Independent



Future Man
Bela Fleck & The
Flecktones



Gilad
ON 3



Hector "Pocho" Neciousup
Miami Independent



Horacio Hernandez



Jessie Caraballo
Marc Anthony



Jesus Diaz
San Francisco



Jimmy DeGrasso
Ministry



Jose Gregorio
Nestor Torres



Jose Rosa
Miami Independent



Johnny Blas



Johnny Conga
Independent



Jose Claussell
Eddie Palmieri



Lalo Davila
MTSU



Luis Cuenca
B-Side Players



Marc Quiñones
Alman Brothers Band



Marco "Ito" Arguinzi
New York



Mario Monaco
New York Independent



Michael Cartellone
Lynyrd Skynyrd



Michael Duffy
Joan Sebastian,
Ozomatli



Michito Sanchez



Nino Sanchez
Jessica Simpson



O.G.
Slightly Stoopid



Olbin Burgos
Gloria Estefan



Omar Hakim



Omar Ledezma
L.A. Independent



Papo Pepin
New York Legen



Papo Rodriguez
Johnny Polanco



Pete Korpela
Lion King



Rafael Pereira
Sasha Lisnichuk



Ramses Araya
Ruben Blades



Ray Colon
New York



Ravi Jakhotia
Ravi Drums



Raymond Carrasquillo
Puerto Rico



Richard Bravo
Carlos Oliva,
University of Miami



Richie Flores
New York



Robert Vilera
Miami



Rolando Morales-Matos
Lion King



Sammy Figueroa
Jazz & R&B Legend



Sammy Garcia
Puerto Rico



Valerie Dee-Naranjo
Lion King,
SNL



Will Kennedy
WK Krew



WUV
P.O.D.



Glen Caruba



Bart Fermie



Dawne Adams
Pet Shop Boys



Eddie Conard
Independent



Lucas van Merwijk



Martin Verdonk



Nils Fisher



Pablo Escayola
James Last Orchestra

Signature Series

Marc Quiñones Signature Timbales Set

ETE-1415MQ

Designed in conjunction with one of today's premier percussionists, Marc's timbale set consists of standard 14 and 15 inch drums fitted with Remo Clear Ambassador heads, and packed with a ton of innovative features that only Pearl can deliver. The Polished Steel Shells have two inverse beads that not only add strength, but also produce a cutting "cascara" sound (side of the shell) not hindered normally by outward facing beads. To further the "cascara" striking area, this set features a 5-Lug Design that is proportioned perfectly for leaving maximum shell space and less lug interference. Tuning is easier than any other timbales on the market, utilizing a top tuning lug design with included socket wrench. This exclusive Pearl design cuts the time changing heads in half - No more nuts and washers falling on the floor! The cowbell post features a Sympathetic Sound Dampening sleeve so your cowbells and blocks do not ring through the stand, and the whole unit can be mounted in seconds using a one wing-nut design. A double braced tilting stand, and our top-selling PBL-30 Clave Block are included.



Q-Popper Timbale Snare w/ Mount

ETE-1205MQ

The Marc Quiñones Signature Q-Popper 12"x5" Timbale Snare is perfect for accenting a traditional Salsa group, as well as an auxiliary add-on to your drum set. With the snares on it "pops" with all the characteristics of a small metal snare drum, yet throw the snares off (via the SR-018 style strainer) and you have an awesome timbale to spark Caribbean flavor to your sound. The Q-Popper matches Marc's Signature steel timbales and comes standard with the NEW PPS-36 Angled Post Adaptor to conveniently mount it off any cymbal or hi-hat stand.



Marc Quiñones
Signature
Timbales Set
ETE-1415MQ

Richie Flores Signature Oak Congas and Bongos

PCW-110DXRF 11" Quinto, PCW-117DXRF 11.75" Conga, PCW-125DXRF 12.5" Tumbá
PBW-300DXRF 7 & 9" Bongos

Why settle for one color when you can have solids, sparkles and fades all in one set of congas and bongos! With Richie Flores NEW Signature drums you can have it all! Richie's exclusive "vertical" fade Lunar Eclipse finish transitions from dazzling Silver to rich Midnight Blue dusted in stellar sparkles as you turn the drums. Fade your congas from left to right, right to left, all Silver Sparkle or all Midnight Blue Sparkle...the color possibilities are limitless! The bongos feature an extra set of holes to allow the shells to be reversed to match the congas. Thai Oak shells with Contour Crown Rims, brilliant chrome plated hardware, and our exclusive Self-Aligning Washer System (S.A.W.S.) for effortless tuning round out the features of these beautiful instruments.

Bobby Allende Signature Fiberglass Congas and Bongos

PCF-110DXBA 11" Quinto, PCF-117DXBA 11.75" Conga, PCF-125DXBA 12.5" Tumbá
PBF-300DXBA 7 & 8.5" Bongos

Bobby demands the best, so he designed his Signature Fiberglass Congas and Bongos to exceed all existing standards, right down to the smallest detail. For example, the seams are invisible, thus giving his congas the look of natural wood. The congas are 28" tall to fit the traditional seated player, and the wider base adds projection and stability. A new rim design on both congas and bongos adds extra comfort while complimenting the fitted Remo Fibreskyn3 heads.



Bobby Allende Signature
Fiberglass Congas
and Bongos



Richie Flores Signature
Oak Congas and Bongos
#527 Lunar Eclipse

Jesus Diaz Signature Cuban Cajons



PCJ-110JD Segundo Cajon(11")
PCJ-120JD Tumbador Cajon(12")
PCJ-100JD Quinto Cajon(10")



Pearl's Folkloric Cuban Cajons are inspired by master Afro-Cuban percussionist, Jesus Diaz, and feature the classic Cuban wedge shape for deep resonating bass tones and cutting slaps. Available in 10", 11", and 12" sizes and pitched in thirds, the Jesus Diaz Signature Cuban Cajons can be played in traditional settings or used as an alternative to congas. All feature 100% wood construction and stand 18" tall. For mounting, drop them into Pearl's Cajon Cradle. It easily attaches to any cymbal stand to firmly hold your 10", 11", or 12" Cajon while standing. Tired of supporting your Cajon between your legs? Simply detach the ring from the stand and the integrated handles become leg rests so your Cradle sits comfortably on your lap... no more pressure on your inner thighs! Inner rubber gaskets protect your Cajon from damage. Instruction manual included.



#620 Café Con Leche

#619 Solar Sparkle

Cajon Stand
PCJ-100S 10"
PCJ-110S 11"
PCJ-120S 12"

Horacio "El Negro" Hernandez Signature Cowbells

Designed by Horacio Hernandez, this series of five cowbells are pitched in accordance to "El Negro's" strictest of standards. Intended for Drumkit and Percussion players, the unique features include two playing surfaces: flat on one side, and curved on the other. The tone is the same, but the distinctive bi-shaped design will give the player the option of striking the bell directly facing in or on the side (like a timbale player). The two-position cowbell bracket will ensure that the wing-nuts will not get in the way when stacking multiple bells and blocks on one post. This makes it much easier to adjust the bells from virtually any position. Another exclusive feature is found on the smallest bell, the HH-1 Bella. Two rubber gaskets separate the mount from the body of the bell offering maximum tone and resonance that is usually "choked" and "dry" with other cowbells of this size. Finished in beautifully plated copper, this professional line of cowbells sound and look like no other on the market.



HH-1 BELLa Hi-pitch Cha-Cha bell
HH-2 ClaBELL Foot-Clave bell
HH-3 ChaBELLa Low-pitch Cha-Cha bell
HH-4 IsaBELL Mambo bell on BD
HH-5 MaryBELL Timbale bell

HH-1 HH-2 HH-3 HH-4 HH-5



PPS-20 Cowbell Footpedal Bracket with HH-2 and P-2000C
The PPS-20 features squared dimples post for maximum support without the "L" rod slipping. Eyebolts/wings and knurled pegs which are reversible; rubber tip or spike.



Congas

Pearl has congas to meet the needs of every player from seasoned professionals to beginners. Our Elite Series offers the highest quality heads with polished Contour Crowns and a choice of shell materials: 100% aged Oak or seamless Fiberglass. Our Primero Pro line features professional-quality construction at an affordable price and a choice of 100% Oak or Fiberglass construction. Primero features outstanding Pearl quality and a choice of 100% Oak or Fiberglass construction at value pricing.

Bongos

Our Bongos offer professional features and authentic styling in a choice of shell materials to perfectly match your Conga Set. Elite Series Bongos feature Contour Crowns and polished steel hardware with a choice of 4 finishes for Oak and 2 finishes for Fiberglass. Primero Pro offers professional features with a choice of 4 finishes for Oak and 3 finishes for Fiberglass. Primero offers maximum affordability with black powder-coated hardware and a choice of Natural finish Oak and 3 Fiberglass finishes.

Travel Conga



- PTC-1100 | NEW | 11" Travel Conga
- PTC-1175 | 11.75" Travel Conga
- PTC-1250 | NEW | 12.5" Travel Conga
- PC-1100TC | NEW | Stand for 11" w/Carrying Bag
- PC-1175TC | NEW | Stand for 11.75" w/Carrying Bag
- PC-1250TC | NEW | Stand for 12.5" w/Carrying Bag
- PPS-50TC | NEW | Stand Bridge

The Travel Congas are available in three standard head diameters: 11", 11.5" and 12.5" yet only 3.5" deep. They feature wood shells and stave construction (identical to our full-size congas) and the Remo FiberSkyn 3 synthetic head for outstanding tone that is unaffected by changes in temperature or humidity. Five precision Allen bolts provide accurate and easy tuning via the included foam-handle Allen wrench.

Pearl's Travel Conga stand is designed specifically with two things in mind: rock solid stability, and lightening fast set-ups and pack-ups. The stand includes a "Y" bracket that attaches to the bottom of your Travel Conga and mounts to the stand centered directly under the drum for maximum stability. The Travel Conga stand comes with a carrying bag that includes a pocket for the optional PPS50TC Bridge that connects two stands together to minimize creeping while performing.



Elite Mahogany Series

Pearl's Elite Mahogany Series of congas and bongos feature our exclusive "Spine-Joint" technology that uses splines to mechanically secure the staves both horizontally and vertically to greatly increase the surface area of the joints for strength that others can't match. The shells feature an inner layer of hard Para Wood for improved volume and increased mid and low frequencies and an outer layer of Mahogany for incredible looks. Another feature is our Contour Crown Rims with a lower profile for greater comfort on your hands and our exclusive Self-Aligning Washer System (S.A.W.S.) that isolate the tension hooks from the inner walls of the lugs for greater tuning ease. The Pearl Elite Mahogany, where state-of-the-art construction creates state-of-the-art sound.



Elite Mahogany Congas

- PCW-110MX 11" Quinto
- PCW-117MX 11-3/4" Conga
- PCW-125MX 12-1/2" Tumba
- NEW COLOR | #531 Cosmic Sparkle

Elite Mahogany Bongos

- PBW-300MX 7" and 9"
- NEW COLOR | #531 Cosmic Sparkle



Elite Oak Congas

#522 Diamond Burst



Elite Oak Bongos

- PBW-300DX 7" and 9"
- #522 Diamond Burst



- PCW-125DX 12-1/2" Tumba

- PCW-110DX 11" Quinto

- PCW-117DX 11-3/4" Conga

Practice Conga

PPC-120 Practice Conga w/Video

The perfect learning tool for the on-the-go percussion student or the seasoned pro warming up backstage. It features a Velcro strap to secure it to your lap and includes a video hosted by Glen Caruba to teach you the basics of hand percussion. Practice anywhere, anytime.



Primero Bongo Attachment

If you use a double conga stand, the PB-700BHS is the simplest way to add bongos to your conga setup. The PB-700BHS features full height and "tilt" adjustment, fits virtually any brand of bongos, and attaches securely to the mounting brackets on our PC-200W and PC-950TW double conga stands.



PB-700BHS

Timbales

Pearl offers Elite Timbales in 3 different sizes: 13", 14" and 15". These professional Timbales feature brass shells with our exclusive 7.5" depths for ultimate tone and projection. Our rolled bearing edges provide cutting "cascara" and the powder coated steel hoops provide classic rimshots. Primero Timbales offer smooth steel shells in 13" and 14" sizes and come complete with a tilting stand, sticks, and cowbell for playability out-of-the-box!

Elite Timbales



- ETB-13 13" Brass Shell

- ETB-14 14" Brass Shell

- ETB-15 15" Brass Shell



Elite Timbales

- ETB-1415 Brass Shell 14"/15" w/PT-900W

Primero Timbales

- PTS-5134 13"/14" Steel w/Tilting Stand Sticks & Cowbell Included

Primero 13" Steel Timbale



- PTE-1336 w/ PPS-36 Mount

Primero Flat Timbs



- PTB-3131 Flat Timbale w/I.S.S. (Brass)

- PTE-3131 Flat Timbale w/I.S.S. (Steel)

Elite Timbale I.S.S. Plate

- PSP-1345 An I.S.S. mounting bracket (less BT-3) for attaching Elite Timbales to racks and tom Arms.





Primero Pro Fiberglass Conga Set
 PFC-202DX 10 / 11" w/o Stand and PFC-120DX 12" w/o Stand
 | NEW COLOR | #627 Neuron Green Fade



Primero Pro Oak Conga Set
 PWC-202DX 10" / 11" #521 Midnight Fade
 (shown with PC-100DX, PC-110DX stands)



Primero Oak Conga Set
 PWC-202 10" / 11"
 #518 Ruby Fade

Primero Oak Bongos
 PWB-67 (6" and 7")
 #518 Ruby Fade
 | NEW |



Primero Pro Fiberglass Bongos
 PFB-100DX 7" and 8.5"
 | NEW COLOR | #627 Neuron Green Fade



Primero Fiberglass Conga Set
 PFC-202 10" / 11"
 #624 Candy Stripe

Primero Pro Fiberglass Bongos
 PFB-100DX 7" and 8.5"
 #626 Gold Marble



Primero Fiberglass Bongos
 PFB-100 (6" and 7")
 #624 Candy Stripe

Primero Pro Fiberglass Conga Set
 PFC-202DX 10 / 11" w/o Stand and PFC-120DX 12" w/o Stand
 #626 Gold Marble

Congas & Bongos Available Finishes

Elite Series			Primero Pro Series						Primero Series							
Oak	Mahogany	Fiberglass	Oak	Fiberglass					Oak	Fiberglass						
#511 Natural	#522 Diamond Burst	#530 Natural Mahogany	#531 Cosmic Sparkle	#602 Bistre Black	#511 Natural	#521 Midnight Fade	#523 Carbon Vapor	#621 Wine Red Marble	#622 Black Marble	#626 Gold Marble	#627 Neuron Green Fade	#511 Natural	#518 Ruby Fade	#602 Bistre Black	#610 Deco Blue	#624 Candy Stripe

Djembes

Djembes are a traditional African instrument that offer a wide variety of sounds and are perfect for drum circles. The Professional Elite Series is available in Oak (12.5" diameter) and Fiberglass (12.5" and 14" diameter). All feature our Contour Crowns for comfortable playing and authentic Goat skin heads for deep lows and crisps highs. Our Primero Djembe is perfect for the beginning percussionist with its durable Fiberglass construction and compact 9.5" size. The PHD-1000 Hide-Away Djembe Stand stays attached to the drum for transport and sets up in seconds by simply swinging the legs outward. The stand includes a side handle for ease of transport and fits virtually all styles and brands of Djembes.



Elite Oak Djembes
 PJW-340
 12 1/2" #511 Natural



Elite Fiberglass Djembe
 PJF-350 14"
 PJF-320 12 1/2"
 #602 Bistre Black



Primero Fiberglass Djembe
 PJF-310
 9 1/2" #610 Deco Blue



Djembe Stand
 PHD-1000

Elite Box Cajon
 PBC-503
 Matte Wine Red w/Natural Front Plate

Primero Box Cajon
 PBC-507 | NEW |
 #507 Gypsy Brown



Elite Batas
 #526 Crimson Sunrise



PBA70 Iya

PBA-60 Itotele

PBA-50 Oconcolo

Cajons

The Primero Box Cajon is constructed from Asiatic Pine and is finished in Gypsy Brown matte lacquer, while our Elite Box Cajon is constructed of a harder Para Wood stained in Amaranth Red. Both feature fully adjustable snares that can be played "on" for Spanish Flamenco-style or "off" for Peruvian-style playing. The front plate is designed for maximum bass and super-sensitive snare response.

Batas

Pearl Percussion Bata drums are now available in Crimson Sunrise, the same beautiful finish featured on our Folkloric Percussion congas and bongos. Additionally, the hardware is now finished in Polished Steel and matches the hardware on our other tunable hand drums. These sacred ceremonial instruments have a thicker Enu (large) head for a deep, rich tone.

Bala Cowbells



BCM-3
Bala Cha-Cha Bell

BCM-5
Bala Fusion Bell

BCM-7
Bala Mambo Bell

BCM-8
Bala Timbale Bell

BCH-10
Hand-Held Campana Bell

BCM-10
Mounted Campana Bell

Primerio Cowbells



BCM-20
King Bala Rock Cowbell
w/Power Flange

BCM-9
King Bala
Timbale Cowbell

BCH-11
Bala Hand-Held Campana
(Hi-Pitched)

PCB-6
6" Bell

PCB-4
4" Bell

**Anarchy
Cowbell**

PCB-20



Cowbells

Pearl cowbells are available in a broad array of sizes and shapes to add diversity and flavor to your kit sound; and nothing completes that Salsa sound like a quality cowbell. If you're looking for power and clarity, look no further than our Bala Cowbells with their distinctive mirror polished, seamless design. Available in 7 different mountable sizes and 2 handheld models, there's a Bala Cowbell that is right for you. Primerio Cowbells are available in 2 sizes: 4" and 6". Each offers great value and tone, superb volume and sturdy construction. No words are needed for the New Anarchy Cowbell. Hit it and get brutal, cutting tone.



ECB-23
Mounted Agogo

ECB-22
Hand-held Agogo

PCB-1030
10" Bell w/PPS-30

PTA-30
Tri-Agogo

PTB-30
Tri-Bells

PDC-50
Phenolic Cowbell Beater

PDC-10
Dual Cowbell Beater

Concert Percussion

Pearl is proud to offer Concert Percussion instruments that are attractively priced for school ensembles, yet engineered with the professional percussionist in mind. Pearl's High-Density Steel Concert Triangles, PET-100 (10"), PET-80 (8"), and PET-60 (6"), offer beautiful clarity with no unwanted overtones. Triangle accessories include the PTC-10 basic triangle clip and the revolutionary PTC-300 Trio Triangle Holder that can accommodate up to three triangles ranging from 6" to 10". Our staggered Double Row 10" Concert Tambourine (PETM-20) has thin stainless steel jingles in a hardwood frame and natural goat skin head. Our concert woodblocks (PCWB-10, PCWB-20, PCWB-30) are made of blended hardwoods and feature a raised spine in the center for easy striking with a mallet or stick. Our Stix-Free Triangle holder has a brass beater underneath two curved felt pads which strikes the mounted triangle horizontally, enabling you to play intricate syncopated patterns, and is fully adjustable to hold 6" to 10" triangles.

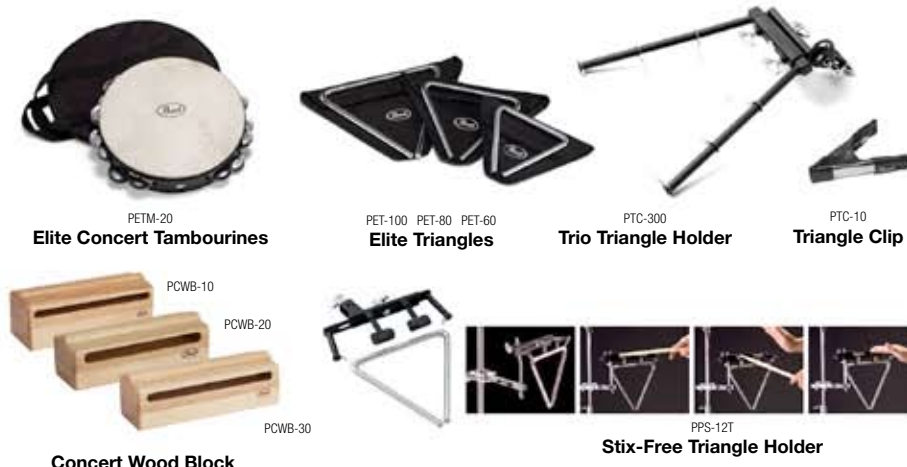

PETM-20
Elite Concert Tambourines

PET-100 PET-80 PET-60
Elite Triangles

PTC-300
Trio Triangle Holder

PTC-10
Triangle Clip



Concert Wood Block



PPS-12T
Stix-Free Triangle Holder

Taiko

All of Pearl's Taiko are made from staved oak which are beautifully finished in a matte natural stain and produce the rich warmth of wood without the expensive price tag of a traditional carved shell. The insides of the shells are shaped using a method called "Hado-Carving" with special reinforcement rings which are placed to break up the unwanted overtones, producing a balanced sonic reflection within the drums. But the sound starts on the outside, with premium cow hide exclusively chosen for Pearl Taiko drums. Pearl's Bachi are from a domestic hardwood in Thailand known as Acacia and offered in three different diameters to suit the size of both the player and Taiko. You will want to protect your investment of these beautifully crafted instruments, so Pearl offers soft padded carrying cases for the larger Miya Taiko.



WOT-12	Miya Taiko 1S/2-Sun
WOT-15	Miya Taiko 1S/5-Sun
WOT-16	Miya Taiko 1S/6-Sun
WOT-18	Miya Taiko 1S/8-Sun
WHT-12	Hira Taiko 1S/2-Sun
WHT-14	Hira Taiko 1S/4-Sun
WST-20BL	Shime Taiko w/Tension Lugs
WOT-120S	Stand for WOT-12
WOT-15160S	Stand for WOT-15/16
WOT-180S	Stand for WOT-18

BAT-30A BAT-20A BAT-10A

Hand Percussion

We offer an ever expanding line of effects from around the world to add flavor and color to your sound with bold improvements over the traditional. The Synthetic Fiber Claves produce a cutting clave sound, and are virtually indestructible. The Metal Guiro provides a unique metal sound and is perfect for Merengue rhythms. The Natural Gourd Guiro has two playing sides for different sound effects. Coated with fiberglass gel in the interior, it has projection and volume, and the rubber ring gives strength to the shell, making this Guiro the last you'll ever purchase. Our Shekere is a precision formed, traditionally shaped fiberglass shell that optimizes projection without the fragility or weight of natural gourds. Our Clave Blocks are neon color-coded synthetic blocks designed with our Chamber Density Variation Technology. This allows consistent shaping of each block, while varying each block's pitch by a third. Our newest addition to complement the mega-popular Anarchy Cowbell is the PBL100 Anarchy Block. Completely black and spike-riddled, this block will cut like an axe through the heaviest metal rhythm sections as a piercing alternative to a rim-shot. Our Gating Cabasa enables you to play tight rhythmic patterns by a turn of the rotator arm. The Shakelets feature Pearl's exclusive Brazilian-style platinellas, called "Ganzinellas". With Shakelets on the wrist endless possibilities are created. Clap your hands, shake them in the air or play them holding a drumstick. They are just plain fun. We have two new tambourines available called the Ultra Grip Tambourine with Jingle Control. The ski-pole, like ergonomic handle, is positioned near the tambourine's center of gravity for comfortable and effortless playing, and the Jingle Control Discs allow the jingles to be selectively muted to control the volume of your tambourine and complement your playing style. Like our popular PTM10GH (Brass Jingle) and PTM10SH (Stainless Steel Jingle) Tambourines each Ultra Grip Tambourine is equipped with Pearl's QuickMount holder that allows the tambourine to go from mounted to hand-held with a flick of your wrist. The new 36 Bar Aluminum Chromatic windchimes features self-dampening parallel swinging chimes for controlled chime sound. A soft roll-up carrying case is included that doubles as a towel that can be draped over a (horizontal) music stand to act as a trap table. The case includes a storage compartment for the optional PWH-20 Windchime Holder.



PCL-10
Fiber Claves



PFG-20
Fiber Combo Guiro



PMG-20
Metal Guiro



PNG-20
Natural Gourd Guiro



PSK-10
Fiberglass Shekere



PBL-10 High (Neon Green) PBL-20 Medium (Neon Yellow) PBL-30 Low (Neon Orange)
Clave Block w/Holder



NEW!
PBL-100
Anarchy Block



CBS-100
Gating Cabasa



PWR-40
Shakelets



PTB-10
TomBourine



NEW!
PTM-50BHR (Brass)
PTM-50SHR (Steel)
Ultra Grip Tambourine



PTM-10GH
Tambourine
w/Brass Jingles



PTM-10SH
Steel Jingle Tambourine
w/Stainless Steel Jingles



PTH-10B (Brass) PTH-10S (Steel)
Headless Wood Tambourines



PLS-30
Liso Shaker
w/Mounting Bracket



PFM-20
Beaded Maracas



PGA-20
Basket Ganzas
(9" x 4")



PGA-30 (Short)
Hex Ganzas



PEC-1
Egg Carton



Wind Chimes

NEW!
PWH-3620A
36 Bar Aluminum Chromatic
Case included



PTG-20
Tang-Tang



PAB-20 High PAB-50 Medium PAB-100 Low
Ash Tone Block



PSC-30
Spirit Chimes
w/Holder & Mallet



PJM-10SH
Hi Hat Jingle Ring



PJC-10SH
Jingle Clamp



PSA-10
Snare Drum Hand Adapter

Brazilian Percussion

Authentic Brazilian Sound

Pearl's line of Brazilian Percussion brings modern refinements and Pearl quality to the traditional Samba musician. Our Repinique line with 10" and 12" Aluminum shells feature etched heads, shoulder strap, and low rims for superior playing comfort. Our super lightweight Cuica features an 8" Goat skin head and comes equipped with a carrying strap and a specially designed sponge. Two models of Pandeiros and a Pandanza with multi function effects and a traditional Tamborim round out the new line. All are offered in the traditional Brazilian colors of bright Blue, Yellow and Green for dynamic looks that will surely get you noticed wherever you play. The lightweight wood shell Surdos allow for hours of comfortable play when worn over the shoulder with the provided strap. They are available in 18" x 22" and 22" x 22" sizes (diameter x depth) and include two-ply tunable heads with an outer ply of synthetic leather for accentuated low-end frequencies. Our patent-pending Leg/Bass Drum Adaptor Kit (PBS30BD) allows your Surdo to be played vertically like a floor tom or horizontally with a pedal like a bass drum. Pearl's new Caixa features a 12" x 4" wood shell, drum key tunable textured heads, and SR-018 style throw-off. It can be played traditionally around the shoulder with the provided strap, or attached to a stand as an auxiliary snare to your drum kit.



Surdo 18"

PBS-1822
(NEW)

Surdo 22"

PBS-2222
(NEW)

Legs & BD Adapter Kit for Surdo

PBS-30
(NEW)

Caixa 12"

PBCX-1204
(NEW)

Repinique 10"

PBR-10 (w/ Strap)

Repinique 12"

PBR-12 (w/ Strap)



Pandeiro 10"

PBP-510
(5 sets platinellas & goatskin head) w/ bag

Pandeiro 12"

PBP-612
(6 sets platinellas & plastic head) w/bag

Pandanza

PDZ-510
w/ agogo bell

Tamborim

PBT-60

Tamborim Stick

PBT-60S

Ganzheiro

PGR-03

Percussion Stands and Brackets

Pearl offers stands for every application, from our economical and lightweight PC-900 stand that accommodates a range of Congas and Djembes, to our PC-1000 QRS Multi stand that provides a solution for all of your instruments.

The PC-2000 Conga Kick Stand is a one-size-fits-all stand packed full of user-friendly features. Designed to accommodate the standing percussionist, the PC-2000 features extendable legs and a contemporary frame designed to perfectly unite two, three, or four stands together.



Quick Release Multi-Stand

PC-1000QRS
Basic Stand
for Congas & Djembes

PC-2000
Conga Kick Stand

PC-900
All-Fit Conga Stand

PB-900W
All-Fit Titting
Bongo Stand

PB-700
Lightweight
Bongo Stand

Holder and Accessories



PPS-30

Adjustable Accessory Holder

PPS-36

Angled Single Post Adapter

PPS-37

Angled Post Adapter

PPS-40

Lug Mount Accessory Holder

PPS-27

Swivel Mount Adapter

PGH-20

Universal Guiro Holder

PPS-20

Foot Pedal Bracket

PCS-10

Cowbell Stacker

PPS-10 & PPS-11

Stix-Free

Folkloric Percussion

This line of congas and bongos features a traditional look with modern innovation. Thicker South American style natural skins and a fiberglass gel coat on the interior seals provide the sound desired by today's players, and that of the classic Cuban sound. The Cata is a bamboo instrument played with sticks. Our Bamboo Claves produce a dry, "airy" tone that is lower in pitch than our "Chin-Chan" Hardwood Claves. The Achere is a single shaker with a handle used for time-keeping, while the Guataca, with scalloped edges for scraping, gives great metallic effects.



#526 Crimson Sunrise

Folkloric Elite Bongos

PWB-300FC
(7" and 8.5")

Folkloric Elite Congas

PCW-125FC
Tumbador (12-1/2")

PCW-110FC
Quinto (11")

PCW-117FC
Segundo (11-3/4")



Cuica

PBC-80



Shekeres

PSK-50FC
(Uno)

PSK-70FC
(Caja)

PSK-60FC
(Segundo)



Shekere Holder

PPS-45
NEW!



Claves

PCL-10FCB
(Bamboo)

PCL-10FCW
(Wood)



Cata w/Holder

PCA-14FC



Achere

PAC-10FC



Guataca

PGT-10FC

Trap Table & Rack

Our popular PTT-1824 Trap Table can now be easily converted into a two-level folding rack without drilling or modifications by simply adding Pearl's new PTR-1824 Add-On Rack. The PTR-1824 installs in seconds using clamps and folds flush with the table for easy pack-up. A unique clamping system allows the included (4) straight and (4) angled 3/8" knurled posts to clamp anywhere onto horizontal or vertical areas of the rack. Also included is a retractable three-legged stabilizer bar for optimum stability.



Trap Table
PTT-1824
(18 X 24")

Trap Table Rack
PTR-1824 + PTR-1824

Trap Table
PTT-1212
(12 X 12")



Trap Table Single Post Adapter
PTR-1824RC3 (For PTT-1824, PTT-1212)



CA-100

75H

75X

PPS-51

PPS-52

PPS-92

Cowbel Holders

Percussion Cases

Pearl's new padded carrying cases include features like ergonomic carrying straps, rubber protective bottoms, top-mounted carrying handles, tuning wrench pouches, and heavy duty double zippers. The PPB100 is made from heavy weight nylon and will fit all Conga sizes.



PSC-125CG
12-1/2"
Conga Bag

PSC-117CG
11-3/4"
Conga Bag

PSC-110CG
10"
Conga Bag

PSC-BB
Bongo Bag

PSC-1118CJ
Cuban Cajon Case

PSC-1213CJ
Box Cajon Case

PSC-2000
Conga Kick Stand Case

PSC-1400J
14"
Djembe Bag

PSC-1250J
12-1/2"
Djembe Bag



PSC-1175TC
Travel Conga Case



Replacement Parts

Ultra-Sound Snares

Pearl's Ultra-Sound snares feature patented Graduated Tension wires for extended dynamic range from ultra soft to ultra loud. Ultra-thin, low mass end plates assure ultra quick response. The end plates feature three mounting options: tunnels or holes for cord mounting and slots for straps. US.PAT.7202405



SN-1320C	20 strands for 13", C-type, w/straps & cords
SN-1320D	20 strands for 13", D-type, w/straps & cords
SN-1320I	20 strands for 13", I-type, w/straps & cords
SN-1420C	20 strands for 14", C-type, w/straps & cords
SN-1420D	20 strands for 14", D-type, w/straps & cords
SN-1420I	20 strands for 14", I-type, w/straps & cords



SN-1442C	42 strands for 14", C-type, w/straps & cords
SN-1442D	42 strands for 14", D-type, w/straps & cords
SN-1442I	42 strands for 14", I-type, w/straps & cords

Replacement Snares



S-022N	20 Strand for 14" w/Cords
S-022NU	20 Strand for 14" w/Cords, Uncoated
S-022NG	20 Strand for 14" w/Cords, Gold Plated
S-022	20 Strand for 14" w/Straps
S-025	20 Strand for 14" long, w/Straps
S-029N	20 Strand for 13" w/Cords
S-030N	24 Strand for 14" w/Cords
S-031N	20 Strand for 12" w/Cords
S-032N	12 Strand for 10" w/Cords
S-033N	12 Strand for 12" w/Cords
S-040	15 Strand for 14" w/Cords, Steel Cable, Thinner Gauge
S-041	15 Strand for 14" w/Cords, Bronze Cable, Thicker Gauge
SPS-18/6	Plastic Strap (6/pkg)
SNC-40/6	Snare Cord (6/pkg)

OptiMount

Our OptiMount Suspension System attaches to the tom's tension rods and floats on rubber cushions, providing the ultimate in stability while allowing the drum to resonate fully without restriction. With OptiMount, the mounting hardware is completely removed from the drum shell, providing a drastic improvement in resonance and sustain.



OPTA-0708/C	for drums 7"-8" deep, 6"-16" diameter, Light Weight Aluminum
OPTA-0910/C	for drums 9"-10" deep, 6"-16" diameter, Light Weight Aluminum
OPTA-1112/C	for drums 11"-12" deep, 6"-16" diameter, Light Weight Aluminum
OPTA-1314/C	for drums 13"-14" deep, 6"-16" diameter, Light Weight Aluminum
OPTA-1516/C	for drums 15"-16" deep, 6"-16" diameter, Light Weight Aluminum



OPT-0708/C	for drums 7"-8" deep, 6"-16" diameter, UltraGrip Wingnut
OPT-0910/C	for drums 9"-10" deep, 6"-16" diameter, UltraGrip Wingnut
OPT-1112/C	for drums 11"-12" deep, 6"-16" diameter, UltraGrip Wingnut
OPT-1314/C	for drums 13"-14" deep, 6"-16" diameter, UltraGrip Wingnut
OPT-1516/C	for drums 15"-16" deep, 6"-16" diameter, UltraGrip Wingnut

I.S.S.

Our standard I.S.S. mounts also remove all mounting hardware from the shell and clamp to the rim providing the quickest, easiest mounting system available today. (US.PAT. 5544561)



IS-0810N/C	1.6mm Steel Hoop, UltraGrip Wingnut
fits 8"~10"	ISS-0810 Vision, UltraGrip Wingnut
IS-0810SL/C	2.3mm Superhoop II, UltraGrip Wingnut
IS-1216N/C	1.6mm Steel Hoop, UltraGrip Wingnut
fits 12"~16"	ISS-1216 Vision, UltraGrip Wingnut
IS-1216SL/C	2.3mm Superhoop II, UltraGrip Wingnut

Die Cast Hoops

MasterCast are the finest die cast hoops available and feature the perfect blend of thickness and mass to improve the depth, clarity, and focus of toms and snare drums.



Model #	Diameter	# of Tension
DC-0805	8"	5
DC-1006	10"	6
DC-1206	12"	6
DC-1306	13"	6
DC-1408	14"	8
DC-1408S	14"	8 Snare Side
DC-1410	14"	10
DC-1410S	14"	10 Snare Side
DC-1410SG	14"	10 Snare Side w/Guard
DC-1508	15"	8
DC-1608	16"	8
DC-1808	18"	8

Super Hoop II

SuperHoop II hoops are precision formed from heavy-duty 2.3mm steel, triple-flanged and engraved with the Super-Hoop II logo.



Model #	Diameter	# of Tension
SH-0604	6"	4
SH-0805	8"	5
SH-1006	10"	6
SH-1006S	10"	6 Snare Side
SH-1206	12"	6
SH-1208	12"	8
SH-1208S	12"	8 Snare Side
SH-1306	13"	6
SH-1408	14"	8
SH-1408S	14"	8 Snare Side
SH-1410B	14"	10
SH-1410S	14"	10 Snare Side
SH-1410SG	14"	10 Snare Side w/Guard
SH-1508	15"	8
SH-1608	16"	8
SH-1808	18"	8

Steel Hoops

Model #	Diameter	# of Tension
RIM-0604	6"	4
RIM-0804	8"	4
RIM-0805	8"	5
RIM-1006	10"	6
RIM-1006SL	10"	6 Snare Side
RIM-1206	12"	6
RIM-1206SL	12"	6 Snare Side
RIM-1208B	12"	8
RIM-1208S	12"	8 Snare Side
RIM-1306	13"	6
RIM-1308B	13"	8
RIM-1308S	13"	8 Snare Side
RIM-1406	14"	6
RIM-1408B	14"	8
RIM-1408S	14"	8 Snare Side
RIM-1410B	14"	10
RIM-1410S	14"	10 Snare Side
RIM-1410SG	14"	10 Snare Side w/Guard
RIM-1508	15"	8
RIM-1606	16"	6
RIM-1608	16"	8

Bass Drum Hoop Protectors



HPP-2	Metal Hoop Protector for Wood BD Hoops
NP-01	Hoop Protector for Metal BD Hoops
NP-347/2	Non-Slip Hoop Protector for Wood BD Hoops (pair)

Masking Covers

The GK-90 and BBC-1 cover the holes of BT-3 and BB-3 brackets that have been removed.



GK-90

BBC-1 for BB-3, w/Gasket, Screws and Nuts
GK-90 for BT-3, inside/outside plates w/Bolts

Stainless Steel Tension Rods

Pearl's Stainless Steel Tension Rods are machined, not forged, from a single piece of stainless steel to the most exacting tolerances in the industry. They feature super-smooth, precise tensioning, with absolutely no play. Each non-plated stainless steel tension rod is matched with a precision-machined brass swivel nut for ultra-precise performance.



SST-5028/6 M5.8 x 28mm (6)
SST-5035/6 M5.8 x 35mm (6)
SST-5038/6 M5.8 x 38mm (6)
SST-5042/6 M5.8 x 42mm (6)
SST-5047/6 M5.8 x 47mm (6)
SST-5052/6 M5.8 x 52mm (6)

Tension Rod Washers

NLW-12/12

MTW-12/12



NLW-12/12 Nylon Washers (12) White
NLW-12B/12 Nylon Washers (12) Black
MTW-12/12 Metal Washers (12)

Tension Rod LockNuts

TNK-10N/10

TL-20/10



TL-20/10 Tension Rod Lock Nuts (10/pkg)
TNK-10N/10 Tension Keeper (10/pkg)

Muffler

External clamp-on muffler for snare drums and toms. By adjusting the pressure and position of the felt pad, excessive overtones can be precisely controlled or eliminated.



OM-1 Clamp-on Muffler, Snare Drum & Toms

Hi-Hat Clutches



DCL-300P

SGC-300P



DCL-300P Drop Clutch, Rubber Washers, Lock Nut
SGC-300P Super Grip Clutch, Rubber Washers, Lock Nut M5.8 x 42mm (6)
CL-300 Clutch, Triple-Lock, Felt Washers, Lock Nut
CL-68N Clutch, Standard, Felt Washers

Chains & Belts

CCA-5

BCA-1



CCA-5 Chain Assy Complete for Eliminator Pedals
CCA-10 Chain Assy Complete for 1000 Series Power Shifter/PowerPro
CCA-1 Chain Assy Complete for 120 Series
BCA-1 Belt Assy Complete for Eliminator Pedals
BCA-10 Belt Assy Complete for 1000 Series

Cams, Beater Weight & Spring

EPAP-1

BW-100

CAM-YL

CAM-PL



EPAP-1 Package: Beater Weight, Purple Cam, Yellow Cam
CAM-PL Eliminator Purple Cam, Aggressive Action
CAM-YL Eliminator Yellow Cam, Inverse Action
CAM-BK Eliminator Black Cam, Linear Action
CAM-WT Eliminator White Cam, Oversized Linear Action
CAM-BL Eliminator Blue Cam, Progressive Action
CAM-RD Eliminator Red Cam, Radical Action
BW-100 Beater Weight, 3 Weights in One

Drum Keys



KGT-100 Gyro Tune Key w/Quick Release Neck Strap
K-030 Hi-Tension Tuning Key
K-050 Tuning Key

Practice Pads

Silencer Rubber Pads



RP-50

Our RP-50 features five rubber discs for silent practicing on drumsets with 12", 13", and 16" toms, and 14" snare drum. A universal-fit bass pad with adjustable straps is also included. They remove easily for resumption of live play.

RP-40C

Our RP-40C Cymbal Silencers effectively reduce the volume of cymbals for practicing. The set includes an 18"/20" cymbal pad, 14"/16" cymbal pad, and a pair for 14" hi-hats.

Bass Drum Pedal Training Pads

BD-10

The BD-10 bass pad is perfect for practicing at home or on the road. The wide pad accommodates double pedals and is specially formulated for extremely low noise and a realistic feel. The universal-fit "hoop" accepts all brands of pedals and adjusts to compensate for different floor surfaces. The BD-10 folds for compact transport.



Training Drum Pads

SD-50

The SD-50 features Pearl's unique rubber pad surface with realistic rebound and near silent performance. The stand and pad use heavy-duty 8mm threading for superior durability and stability.



Pearl Drum Heads

Pearl's exclusive ProTone heads, standard equipment on Vision, and Forum, are specially designed to deliver maximum performance and durability. They're affordably priced and available separately in a wide range of models to satisfy virtually any playing style.

Bass Drum Heads

ProTone bass heads feature built in Perimeter EQ rings that provide "out-of-the-box" playability with little or no additional z. ProTone batter heads are available on coated and clear single-ply and clear two-ply versions. ProTone



resonator heads feature the Pearl logo and are available in Coated and Ebony (black). The Black Beat head is similar to the ProTone Ebony but without the Perimeter EQ system.



Bass Drum - Front Heads w/LOGO

Size	ProTone EBONY w/Perimeter EQ	Size	ProTone COATED w/Perimeter EQ	Size	BLACK BEAT
18"	PTH-18PL	18"	PTH-18PL	18"	PTH-18PL
20"	PTH-20PL	20"	PTH-20PL	20"	PTH-20PL
22"	PTH-22PL	22"	PTH-22PL	22"	PTH-22PL
24"	PTH-24PL	24"	PTH-24PL	24"	PTH-24PL

Bass Drum - Batter Heads

Size	ProTone CLEAR w/Perimeter EQ	ProTone COATED w/Perimeter EQ	ProTone CLEAR Double Ply
18"	PTH-18EQ	PTH-18CEQ	---
20"	PTH-20EQ	PTH-20CEQ	PTH-20D
22"	PTH-22EQ	PTH-22CEQ	PTH-22D
24"	PTH-24EQ	PTH-24CEQ	PTH-24D

Tom Heads

ProTone tom heads are made with a proprietary film specially designed for drumheads for outstanding tone and durability. Whether you like the quick attack of single-ply heads or the wetter, fatter sound of two-ply heads, ProTone has you covered. ProTone tom heads are available in coated and clear single-ply and clear two-ply versions.

Pro Tone Tom Heads

Size	COATED-Single Ply	CLEAR-Single Ply	CLEAR-2Ply
8"	PTH-08C	PTH-08	PTH-08D
10"	PTH-10C	PTH-10	PTH-10D
12"	PTH-12C	PTH-12	PTH-12D
13"	PTH-13C	PTH-13	PTH-13D
14"	PTH-14C	PTH-14	PTH-14D
15"	PTH-15C	PTH-15	PTH-15D
16"	PTH-16C	PTH-16	PTH-16D
18"	PTH-18C	PTH-18	PTH-18D



COATED-Single Ply



CLEAR-2 Ply



CLEAR-Single Ply

Snare Drum Heads

Pearl snare side heads feature excellent stretch resistance for long wear and outstanding sensitivity.

Snare Drum Heads

Size	SNARE SIDE
13"	SS-13S
14"	SS-14S



Muffle Drum Heads

Muffle Heads are made with a high-strength woven material that allows air to escape for dramatically reduced volume. Most any acoustic kit can be converted to a 24/7 practice kit by simply switching the batter heads to Muffle Heads.

Muffle Heads

Size	Model #	Size	Model #
8"	MFH-08	14"	MFH-14
10"	MFH-10	16"	MFH-16
12"	MFH-12	20"	MFH-20B
13"	MFH-13	22"	MFH-22B

