

A photograph of a Pearl drum set with a shimmering copper finish. The set includes a bass drum, snare drum, and three toms, all mounted on a chrome hardware stand. Two cymbals are visible on the left. The background is a textured, greyish-blue wall. The Pearl logo is prominently displayed in the upper center, with the text '2014 GENERAL CATALOG' below it. The Pearl logo on the bass drum head is also visible.

# Pearl®

2014 GENERAL CATALOG

Pearl

## THE CHOICE IS YOURS.

PEARL HAS BEEN CRAFTING PERCUSSION INSTRUMENTS DESIGNED TO FIT THE NEEDS OF EVERY DRUMMER SINCE 1953. NO MATTER WHERE THE PLAYING ROAD TAKES YOU, PEARL HAS THE RIGHT DRUM SET OPTIONS TO MAKE YOUR VOICE HEARD AT EVERY STEP ALONG THE WAY.

### MASTERWORKS



#### CUSTOM CRAFTSMANSHIP FOR THE MASTER PERCUSSIONIST.

The dream destination for the Pro drummer that wants true control. Every element of the kit's sound, look, and feel is player-selected from a limitless palette of custom options. Hand-crafted to heirloom perfection for the ultimate custom drum statement.

PAGES 2 - 5

### REFERENCE



#### SONICALLY SELECT DRUM PERFORMANCE.

The best custom options from the Masterworks realm, pre-selected to draw the best in sound and playability from each drum. Optimum pro performance for high-volume, high-capacity playing presence.

PAGES 6 - 7

### REFERENCE PURE



#### UNRESTRICTED TONAL RESPONSE.

The sonically-select Reference formula in a thin drum shell format. Unrestricted tone for close-field articulation with a warm, resonant vibe. Ideal for controlled environments and concert settings where extended tuning range is paramount.

PAGES 8 - 9

### MASTERS MAPLE



#### THE LEGENDARY MLX MAPLE SOUND.

The road-proven, time-tested combination of North American Maple shells and MasterCast hardware. Warm, thunderous punch and stunning Artisan II exotic lacquer finishes make it perfect for the touring pro.

PAGE 10

### MASTERS BIRCH



#### NATURALLY BALANCED FOR STAGE & STUDIO.

Now with all Birch shells, the Masters line gets an added dose of cut and clarity. Exceptional for the road as well as recording, Masters Birch includes all the custom touches of Master's Maple, with jaw-dropping premium finish options.

PAGE 11

### SESSION STUDIO CLASSIC



#### THE RETURN OF PERFORMANCE.

With traditional shallow-depth toms for increased articulation, The 'Classic' is back with a unique Kapur/Birch hybrid shell. Powerful attack, added tonal clarity, and stunning lacquer finishes make it fit in any pro playing environment.

PAGES 12 - 13

### VISION VBL



#### NEXT LEVEL PERFECTION.

Truly a sight to behold, Vision gives the next-level drummer a strong foundation to build a career on. Quality high-gloss lacquer finishes, durable hardware, and stellar tone make it the clear choice for moving your drumming voice forward.

PAGE 14

### EXPORT



#### THE LEGENDS OF TOMORROW, PLAY EXPORT TODAY.

The kit that spawned a thousand drumming legends is back for a new generation. True to its legacy of quality and durability, Pearl's new Export is built stronger than ever to give the student drummer's lifetime of play a strong beginning.

PAGES 16 - 17

# Pearl®

## 2014 GENERAL CATALOG

All specifications and availability subject to change without notice.

### DRUM SETS

2-5	Masterworks
6-7	Reference Series
8-9	Reference Pure Series
10-11	Masters Maple / Birch Series
12-13	Session Studio Classic Series
14	Vision Birch Lacquer Series
15	Rhythm Traveler & Pod
16-17	Export Series
18-21	ePro & Accessories

### HARDWARE

32-33	Demon Drive
32-33	Demon Chain
34	Eliminator
35	P-930
36-37	Hi-Hat Stands
38	Snare Stands
39	Drum Thrones
40-41	Boom & Straight Cymbal Stands
42-43	Racks & Tom Stands / Arms

### SNARE DRUMS

24	Reference
25	Masters
25	Session
26	Free Floating
27	Hybrid Exotic
28	SensiTone
29	SensiTone Premium
30	Signature
31	Effect

### PERCUSSION

44-45	Signature Congas & Bongos
46-47	Cajons & Accessories
48	Timbales
49	Cowbells
48-49	Frame Drums & Accessories
50	Djembes & Folkloric Percussion
51	Brazilian & Concert Percussion
52	Hand Percussion
53	Percussion Stands, Bags & Holders

54-55 Replacement Parts

## THE BEST WARRANTY IN THE INDUSTRY!\*

### COMMITTED TO THE HIGHEST LEVEL OF CUSTOMER SATISFACTION.

The Pearl Lifetime Warranty is a statement of confidence to our customers to the reliability of Pearl products. Pearl drums, stands and hardware are designed and manufactured to the highest standards in quality, style, appearance and playing performance. This lifetime warranty reflects a tradition of excellence and a commitment to superior engineering and craftsmanship dedicated to you, the drummer. The Pearl lifetime warranty is our pledge to you that we will proudly stand behind our product for as long as you own it. *Buy it once, play it for life.*



- Drum Set/Concert wood and metal shells for the Lifetime of the Original Owner.
- Foot pedals, hi-hat stands, cymbals stands, boom cymbal stands, snare drum stands, throne bases, floor-standing tom stands, floor-standing cymbal/tom stands, concert stands, racks and rack accessories, cymbal holders and multi-clamps for the Lifetime of the Original Owner. Some exceptions apply.
- Drum Set claws, tension rods, swivel nuts, spurs, tom brackets, tom holders, strainers, and nuts and bolts for the Lifetime of the Original Owner.
- Rotationally molded cases for the Lifetime of the Original Owner.
- The LIFETIME WARRANTY applies to the aforementioned Pearl products purchased from June 15, 2009.

\* This warranty is valid only in the United States.

# MASTERWORKS

CUSTOM CRAFTSMANSHIP FOR THE MASTER PERCUSSIONIST.



**YOU'VE ARRIVED.  
IT'S TIME TO TELL THE WORLD.**

Since 1999, Pearl's hand-crafted Masterworks drums have given the professional drummer the tools to make a totally custom statement with new heights of perfection. The philosophy is simple: let the drummer call the shots on the construction, sound, look, and feel of the kit. Truly custom options - from shell composition and thickness, to hardware selection and finish, even bearing edges and a virtually endless pallet of custom finishes. All selected by and built for you by the most elite craftsmen in the drum world. For the ultimate personal and performance statement, Masterworks puts you in control.



**SHELL MATERIALS**  
LET YOUR EARS DECIDE

## SHELL THICKNESS

### PRECISION TONAL CONTROL



*Masterworks allows you to further tailor your drum tone by selecting the thickness of each shell.*



### THIN (4-ply, 5mm w/ 4-ply Reinforcement Rings)

Great resonance and sustain with top-end "spike." Maximum tonal note for the near-field environment.



### MEDIUM (6-ply, 7.5mm)

Exceptional for general-purpose play. Excellent projection with full-bodied wood tone.



### THICK (8-ply, 10mm and 10-ply, 12.5mm)

Maximum cut and projection with subdued sustain.

## MAPLE

**The perfect blend of tone, attack, and body.**

- Ideal for general purpose applications.
- Equal tonal amounts of hi-end attack, mid-range body, and low-end punch.
- Hand-selected for proper density, grain consistency, and color.
- North American hardwood with rich, even grain.

## BIRCH

**The precision choice for high-volume cut and power.**

- Best suited for live, high-volume environments.
- Offers boosted hi-end cut with mellow midrange.
- Natural EQ delivers articulate stroke with shorter, even decay.
- North American "white" wood with marbled, subdued grain.

## MAHOGANY

**Deep, powerful punch with dark, elegant tone.**

- Boosted bottom-end perfect for controlled rooms/studios.
- Speaks with rich warmth from low-end register.
- Beautifully smooth midrange sustain with hi-end roll-off.
- Porous African wood with rich, dark texture and grain.

## COMPOSITE SHELL

**The Ultimate Hybrid.**

- Custom configure a kit down to the wood plies used for shells.
- Sonically blend the characteristics of different wood types.
- Maple/Birch ideal for outer plies, inner Mahogany plies boost bass.
- Plies must be specified in groups of 2 for cross-lamination panels (i.e. 2 outer Maple + 2 inner Mahogany = 4 ply shell, etc.)

## BEARING EDGE OPTIONS

Nothing influences your drum's overall response than the bearing edge. That's why Masterworks gives you three bearing edges from which to choose.



**45 DEGREES**  
Provides the perfect blend of attack and warmth.

**ROUNDED 45**  
Boosts mid to high frequencies as a result of greater head-to-shell contact.

**FULLY ROUNDED**  
Provides maximum head-to-shell contact for the greatest boost in mid to low range frequencies.

## HARDWARE COLOR

All Masterworks Series drums are available in your choice of Chrome, Gold, or Black Chrome plated drum hardware.

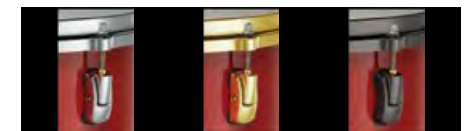

CHROME

GOLD

BLACK CHROME

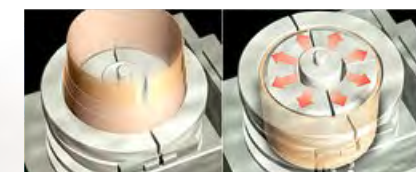

**ASSURES MANUFACTURING EXCELLENCE. EVERY TIME.**

To create the ultimate drum shell, Pearl's proprietary Superior Shell Technology begins with select woods chosen for their unique acoustic attributes. Each is milled to precise thickness with overlapping scarf joint seams and saturated with Pearl's exclusive "AcoustiGlue," creating optimum resonance by drying to the exact consistency of the wood. Finally, the plies are cross-laminated in high-temperature molds at 1000 PSI of hydraulic pressure, producing superior tone and extreme strength.

# MASTERWORKS

COMPLETELY CUSTOM. TOTALLY HANDMADE.



NO ASSEMBLY LINE. NO BOUNDARIES.

*Define Yourself.* Masterworks drums truly represent all that is possible. There is no inventory or assembly line. Every drum in your kit is designed by and hand-built for you - to your exacting specifications - by Pearl's elite team of Masterworks Craftsmen. Masterworks drums are as individual as you are: like no other you have heard or seen before.



THE ULTIMATE STATEMENT IN DRUMS

CUSTOM SHELL THICKNESS

CHOICE OF COMPOSITION

CHOICE OF HARDWARE COLORS

CHOICE OF BEARING EDGE OPTIONS

ARTISAN FINISHES

NO PREFABRICATION

# REFERENCE SERIES

SONICALLY SELECT DRUM PERFORMANCE.

REFERENCE 20 PLY  
Snare Drum

Of the many Reference Series snare drums available, our Reference Series wood snare drum uses 6 inner plies of Birch united with 14 outer plies of Maple for a staggeringly thick 20 ply shell. The 45 Degree bearing edge brings all 20 plies to the party in a highly focused sweet spot. This projects the volume that you would expect from such a thick shell without losing sensitivity or articulation.

## REFERENCE SERIES: THE STANDARD TO WHICH ALL DRUMS ARE JUDGED.

All drums are not created equal. Toms, snares, and bass drums each have a specific application and voice, whether great or small. So why make them all with the same wood type and bearing edge?

With this concept in mind, Pearl explored the many options in the Masterworks crafting process to find the perfect combination of shell material, thickness, and bearing edge profile for each individual size and type of drum. No weak links, no compromises; just pure performance across the harmonic spectrum.

Reference Series Drums are the product of what became a two and a half year search for harmonic perfection. Drums in a kit are meant to function together as a single instrument. So each Reference drum is individually engineered to channel the best sonic character for that drum's intended voice. The result is a drum kit so dialed-in for optimum sound quality and performance, it is truly the reference standard.

### REFERENCE SPECIFICATIONS

SHELLS	Maple, Birch & African Mahogany
SNARE	20 Ply Matching 13 x 6.5, 14 x 5 or 14 x 6.5"
FINISH	Super High Gloss Lacquer/Lacquer Sparkles**
HEADS	Remo Clear Emperor Tom, Powerstroke3 Bass
TOM MOUNTS	Aluminum OptiMount Suspension System
TOM ARMS	Sold Separately
DRUM HARDWARE	Chrome, Black Chrome or Gold Plated
HOOPS	MasterCast Die-Cast Hoops
LUGS	BRL Bridge Lugs with Swivel Function

\*Sold Separately \*\*See full Color Chart on back cover



#152 ANTIQUE GOLD



RF924XPC103  
#103 PIANO BLACK



Bridge style lugs and floor tom leg brackets provide maximum resonance with minimal shell contact. Pearl's revolutionary BRL lugs assure the ultimate in head seating and tuning integrity. The unique swivel function allows the tension rods to align perfectly into the lugs so there's no lateral pressure against the hoops, thus assuring maximum resonance and sustain.

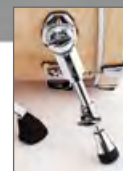

Our telescoping spurs feature rubber or spike tips for maximum traction control. The high-grip rubber tip can be retracted to allow a recessed spike to be exposed for maximum "bite" on carpeted surfaces.



All Reference snare drums feature Pearl's SR-1000 Glide-Lock Strainer, which includes a locking throw off lever and tension knob that won't loosen no matter how hard you play. Low-friction technology permits smooth gliding action for ultra quiet, super precise motion. US Patent #7220905, #7301087, #7365256

Stock finishes listed below.

\*\*See full Color Chart on back cover for all Special Order Finishes.



# REFERENCE PURE SERIES

## UNRESTRICTED TONAL RESPONSE.

Reference Pure proudly builds upon the Masterworks philosophy started by Pearl's original Reference Series Drums. Using the same shell composition formula as the original (number and type of wood plies, task-specific bearing edges, etc.) the highly resonant qualities of Reference Pure's lower-mass, thinner shell assure an uninhibited shell-focused tonality that responds immediately in any playing environment.



Reference Pure snare drums feature ultra-thin "Evenply" shells with 4 outer plies of Maple for a smooth, balanced sound with 2 inner plies of Birch for extra cut and projection. The 45 Degree bearing edges provide superb sensitivity and pinpoint articulation.



## THE REFERENCE PURE DIFFERENCE:

- Ultra-thin "Evenply" Shells (About 30% thinner than Reference) resonate freely with the lightest touch. We reduced the tom thickness from 7.5 to 5.4mm thick and floor toms and bass drums from 10mm down to 7.2mm.
- Shell hardware mass decreased by 30%, allowing better vibration transference to the shell from the head.
- 1.6mm FatTone Hoops' exclusive hemmed/welded edge (US Pat. #8367917) gives increased strength to low-mass design.
- STL Swivel Tube Lugs allow for increased resonance, minimal shell contact, and precisely aligned, no-bind tuning.

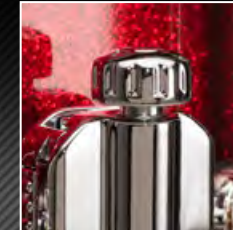
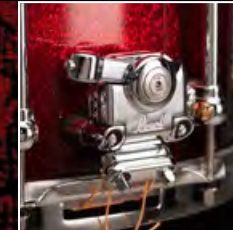

Aluminum OptiMount Suspension System mounts to the tension rods and are insulated from metal to metal contact.

Pearl's Golden Ratio Air Vent (US Patent #7485791) is precision placed on toms to increase low-end response, while low-mass, low-contact STL lugs and floor tom brackets allow for increased shell sustain.

Air Suspension Rubber Tip (US Patent #5881981) isolates the tom from the floor, preventing tonal choke and increasing resonance.

Pearl's SR-1000 Glide-Lock Strainer's locking throw off lever and tension knob assures worry-free, slip-free performance from all Reference Pure Snare Drums. (US Patent #7220905, #7301087, #7365256.)



RFP924XSPC377  
#377 SCARLET SPARKLE BURST



RFP924XPC103  
#103 PIANO BLACK

## REFERENCE PURE SPECIFICATIONS

SHELLS	Low Mass Evenply Maple, Birch & African Mahogany
SNARE	6 Ply Matching 13 x 6.5, 14 x 5, 14 x 6.5"
FINISH	Super High Gloss Lacquer / Lacquer Sparkles **
HEADS	Remo Clear Emperor Tom, Powerstroke3 Bass
TOM MOUNTS	Aluminum OptiMount Suspension System
TOM ARMS	Sold Separately
HOOPS	Low Mass FatTone Hoops
LUGS	Low Mass STL Swivel Tube Lugs
	*Sold Separately

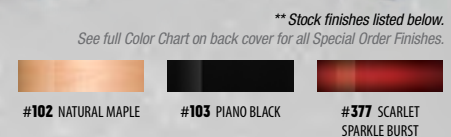

\*\* Stock finishes listed below. See full Color Chart on back cover for all Special Order Finishes.

# MASTERS MAPLE + BIRCH

MCX SERIES + BCX SERIES

THE LEGENDARY SOUND OF PEARL.

Masters Maple features the same 6 ply Maple shells and quality drum hardware that has made the name Masters synonymous with excellence. Never before has the legendary Masters sound been available to so many.

Masters Series shells are formed using Pearl's exclusive Superior Shell Technology (SST) that assures sonic perfection, road-worthy durability, and years of musical enjoyment and performance.

Choose from either **100% Maple** for even distribution of lows, mids, and highs or **100% Birch** with boosted lows and highs with slightly less mids.

MORGAN ROSE, SEVENIST

*Masters*



MCX924XSPC810  
#810 ASH FADE TAMO

CHOICE OF  
**100% MAPLE**  
OR **100% BIRCH**



Pearl Masters Maple & Birch are adorned with MasterCast Die-Cast Hoops, the finest die cast hoops available, and feature the perfect blend of thickness and mass to improve the depth, clarity and focus of the drums.

The OptiMount Suspension System attaches to the tom's tension rods, and provides the ultimate in stability, while at the same time allowing the drum to resonate fully without restriction.



To maintain optimal resonance, Masters Maple & Birch kits feature professional hardware including SP-30 spurs, LB/LG-40 floor tom legs, MasterCast Die-Cast Hoops, OptiMount Suspension System, CL bridge lugs and Air Suspension Feet for road-worthy dependability and USA Remo heads for superior sound.

All Masters drums feature Pearl's proprietary 38-step high-gloss and Artisan II Lacquer finishes. This "green" technology of the Artisan II Lacquer finishes gives Masters Maple and Birch drums the rich look of exotic veneers, without endangering rare wood species.



MASTERS BIRCH  
#818 LAVA BUBINGA

## MASTERS MAPLE: PREMIUM TONE FOR THE TOURING PRO

Truly a set worthy of its name, Masters Maple delivers the essentials touring players rely on for pro performance. Derived from Pearl's legendary MLX shell, the 6-ply all Maple shell on Masters Maple made drumming history with Jeff Porcaro, Tommy Lee, and Dennis Chambers; now it's ready to do the same with you at the helm.

### MASTERS MAPLE SPECIFICATIONS

SHELLS	6 ply 100% Maple 7.5mm
SNARE	Matching 14 x 5.5" or 14 x 6.5"
FINISH	Super High Gloss & Artisan II Lacquer
HEADS	Remo Clear Ambassador Tom, Powerstroke3 Bass
TOM MOUNTS	OptiMount Suspension System
DRUM HARDWARE	Chrome
HOOPS	MasterCast Die-Cast Hoops
LUGS	CL Bridge Lugs

\*Sold Separately

### MASTERS BIRCH SPECIFICATIONS

SHELLS	6 ply 100% Birch 7.5mm
SNARE	Matching 14 x 5.5" or 14 x 6.5"
FINISH	Super High Gloss & Artisan II Lacquer
HEADS	Remo Clear Ambassador Tom, Powerstroke3 Bass
TOM MOUNTS	OptiMount Suspension System
DRUM HARDWARE	Chrome
HOOPS	MasterCast Die-Cast Hoops
LUGS	CL Bridge Lugs

\*Sold Separately

## MASTERS BIRCH: BRINGING THE POWER BACK TO THE ROAD

New to the Pearl Masters line is Masters Birch, bringing all the features of Masters Maple but with a 6-ply all Birch shell. Renown for its "Natural EQ" sound in studio and live applications, Birch's boosted low and high tones power through amplification and make the drummer's voice heard with barking clarity.

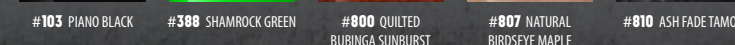

# SESSION STUDIO CLASSIC SERIES

THE RETURN OF PERFORMANCE.

The Classic is back, returning in beautiful finishes, featuring the tom sizes that ruled back in the day. Create the sound that caught your ear and inspired your inner groove.

**GENE HOGLAN**  
DETHKLOK / TESTAMENT / DEATH



The nucleus of the Session Studio Classic sound, warm resonant Kapur surrounded by the brightness of Birch finished with a perfect 45 Degree bearing edge. This timeless combination creates a shell with powerful attack and beautiful tonal decay. Fitting for virtually any style of music or venue.

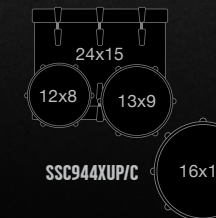
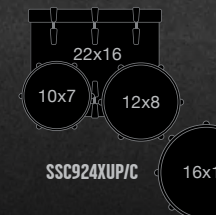
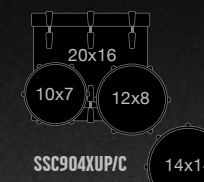

By crafting the shells with slightly more shallow depths, Session Series' unique shell composition allows energy from the drummer's hit to flow freely through the drum. This creates a livelier, punchy tonality reminiscent of the chart-topping kits of yesterday.



SSC924XUP/C  
#110 SEQUOIA RED

**WILL KENNEDY**  
THE YELLOWJACKETS



The OptiMount Suspension System attaches to the tom's tension rods, and provides the ultimate in stability, while at the same time allowing the drum to resonate fully without restriction.

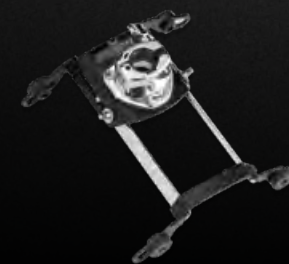

Session toms and snare drums feature rigid yet low-mass SuperHoop II Rims for ease of tuning and optimum resonance. All drums feature classic Session "RL" Series lugs.



SSC924XUP/C  
#106 ANTIQUE IVORY

SSC924XUP/C  
#361 VINTAGE COPPER SPARKLE



## SESSION SSC SPECIFICATIONS

SHELLS	6 ply Birch / Kapur 7.5mm
SNARE	Matching 14 x 5.5" or 14 x 6.5"
FINISH	Super High Gloss Lacquer
HEADS	Remo Clear Pinstripe Tom, Powerstroke3 Bass
TOM MOUNTS	OptiMount Suspension System
DRUM HARDWARE	Chrome
HOOPS	SuperHoop II
LUGS	RL Lugs

\*Sold Separately

## CLASSIC SOUND. AMAZING VALUE.

Session Studio Classic without question is the ultimate value in drums. Offering many of the ground-breaking features normally found on drums that cost substantially more. Session Studio Classic is the perfect "Step up" kit for the aspiring musician.

Blended shells of Birch and Kapur provide solid punch and volume for a sophisticated tonal range. SSC features a diverse selection of shell sizes to fit your style and taste, including bass drums from 20" to 24", matching snare drums and six Classic Pearl high gloss lacquer finishes.



# VISION BIRCH LACQUER SERIES

NEXT LEVEL PERFECTION FOR THE DRUMMER WHO KNOWS THE DIFFERENCE.

Truly a sight to behold, Vision gives the next-level drummer a strong foundation to build a career on. Quality high-gloss lacquer finishes, durable hardware, and stellar tone make it the clear choice for moving your drumming voice forward.

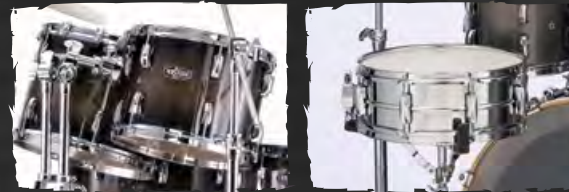

By removing the mounting hardware from the drum, I.S.S. tom holders allow the shells to vibrate freely for maximum resonance and sustain.

Pearl offers 3 VBL configurations, and they all come with Remo two-ply heads and chrome plated Steel SensiTone snare drum. These incredible sounding drums are offered in five exclusive High-Gloss Lacquer Finishes.



VBL-925S/C244\*  
#244 NATURAL BLACK BURST

\*Shown with matching snare. Comes with chrome SensiTone.

## VISION VBL SPECIFICATIONS

SHELLS	6 ply 100% Birch 7.5mm
SNARE	14 x 5.5 Steel SensiTone
FINISH	High-Gloss Lacquer
HEADS	Remo Clear Tom Head, Powerstroke Bass Head
TOM MOUNTS	I.S.S. Mounting System
DRUM HARDWARE	Chrome
HOOPS	1.6 mm Steel
LUGS	TL Lugs



Vision Birch Lacquer is Pearl's most affordable 100% Birch drum set. Birch has long been recognized for its focused, naturally EQ'ed sound, ideal for both stage and studio.



VBL-925S/C239  
#239 GRAPHITE



Muffle Heads (mesh) & Plastic Cymbals for Silent Practicing

# RHYTHM TRAVELER

Easy to transport and easy to practice, the ground breaking concept kit Rhythm Traveler is a compact gigging and practice kit all in one. This complete 5pc kit includes professional quality 2 ply "ProTone" heads and 13" and 16" cymbals for live performance, and silent mesh heads and plastic cymbals for quiet practicing. Whether you are a beginner just starting out, or a gigging drummer who needs a convenient practice set, the Rhythm Traveler is the perfect solution.



RT-705HBCM31

## RHYTHM TRAVELER RT SPECIFICATIONS

SHELLS	9 Ply Mahogany	TOM MOUNTS	Gear
SNARE	13" x 5"	DRUM HARDWARE	Black
FINISH	#31 Jet Black	HOOPS	1.6mm Steel
HEADS	Plastic & Mesh	LUGS	BRL-Look

# RHYTHM POD

SHELLS	9 Ply Mahogany
SNARE	12" x 5"
FINISH	Covered
HEADS	Plastic
TOM MOUNTS	Gear
DRUM HARDWARE	Black
HOOPS	1.6mm Steel
LUGS	Standard

The Rhythm Traveler Pod kit gives you all the sound of the original Rhythm Traveler, but takes portability to a new level. Rhythm Pod rack toms nest for easy transportation and you'll be amazed by the thunderous sound from the 16"x13" bass drum. The Pod Kit comes standard with 2 ply "ProTone" heads and silent mesh heads, a bass drum pedal, cymbal arm, hi-hat stand plus a 13" Brass cymbal and 13" Brass Hi-hats. Rhythm Pod drums are offered in three covered finishes.

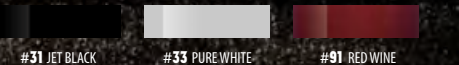

RT-56533

# EXPORT SERIES

THE LEGENDS OF TOMORROW, PLAY EXPORT TODAY.

Export Series now incorporates Pearl's SST (Superior Shell Technology), Opti-Loc tom mounts, all-new 830 Series Hardware with a P-930 Pedal, and a choice of five amazing stocking finishes.



Brian Frasier Moore Justin Timberlake  
EXPORT OWNER



EXPORT #91 RED WINE

EXPORT #33 PURE WHITE

### CONFIGURATIONS

EXX725	EXX725S	EXX705
22x18	22x18	20x18
12x8	10x7	10x7
13x9	12x8	12x8
16x16	16x16	14x14
14x5.5	14x5.5	14x5.5

Includes HWP-830 Hardware

### EXPORT SPECIFICATIONS

SHELLS	Poplar and Asian Mahogany Blend
SNARE	14 x 5.5 Matching Wood Snare
FINISH	Choice of 5 Covered Finishes
HEADS	Remo Clear Tom Head, Powerstroke Bass Head
TOM MOUNTS	Opti-Loc Mounting System
TOM ARMS	TH-701
DRUM HARDWARE	Chrome
HARDWARE	P-930, BC-830, C-830, H-830, S-830



EXPORT #702 ELECTRIC BLUE SPARKLE



EXPORT #31 JET BLACK

EXPORT #21 SMOKEY CHROME



### 830 SERIES HARDWARE

Without a doubt the most sophisticated hardware ever offered on a drum kit at this price. The BC-830 Boom stand, C-830 Cymbal stand, and S-830 Snare Drum stand all feature infinitely adjustable Uni-Lock Tilters for pinpoint positioning. Robust 1" diameter base tubes and 7/8" diameter center tubes with sturdy double-braced tripods provide exceptional rigidity and stability. The H-830 Hi-Hat stand features swivel legs that accommodate double pedals. The P-930 drum pedal combines the styling and performance of the Demon Drive pedal with the Eliminator interchangeable cam technology for the ultimate in power, speed, and control.



Reference inspired blended shell construction uses the classic sound of Poplar combined with inner plies of Asian Mahogany for strong volume and assault with deep resonance and sustain.

Export comes equipped with the all new P-930 drum pedal. This drum pedal combines the long board design of our Demon Drive drum pedal with the interchangeable cam design of our Eliminator drum pedal for amazing performance and value.

Export rack toms are equipped with Pearl's new Opti-Loc Mounting System that features a triangular design with two tension rod attachment points and another through one of the drum's two air vents. Rubber isolators at all connection points allow the drums to vibrate freely for maximum sustain and resonance while providing absolute and wobble-free performance.



P-930 DRUM PEDAL

# OPRO SERIES

REAL ELECTRONIC DRUMS

TOMMY LEE  
MÖTLEY CRÜE

EXX725/C33  
#33 PURE WHITE  
WITH EPADRBM-25  
CONVERSION KIT



## ePRO LIVE

ePro Live is a revolutionary electronic drumset that features real drum sizes and real drum shells, not a collection of little practice pads, that allows natural playability and familiarity so drummers can instantly transition between acoustic and electronic drums. It comes complete with a full-featured ICON-style rack and professional-grade tom and cymbal holders for rock-solid dependability. The TruTrac Electronic Drumheads feel like real heads and have two-zones (center and rim) on the toms and snare.

The real look of the ePro Live starts with the real sizes of the drums. The set features 10", 12" and 14" toms, a 14" snare drum, and a 20" bass drum, so the drummer no longer has to change their playing mechanics to adjust to a set full of 8" practice pads.

EPLX205P/B  
#464 QUILTED MAPLE FADE  
WITH E-CLASSIC CYMBALS  
*(Traditional rubber cymbals also available. Throne not included.)*



## ePRO POWERED BY EXPORT

Electrify your Export (or any acoustic kit) by adding TruTrac Electronic Drumheads and r.e.d. Box Drum Module. Choose from four TruTrac Acoustic to Electronic Conversion Kits in popular configurations or customize your set-up with separate TruTrac Components including the NEW TruTrac Hi-hat coming in Spring 2014.



The ultimate goal of a drum module is to reproduce the REAL SOUND of drums. The r.e.d. box is Pearl's drum module and accommodates the original acoustics of 1000 High Definition sounds and 150 High Definition kits. The sound library includes acoustic and vintage drums, electronics from beat machines to modern digital and a variety of orchestral, concert and world percussion instruments.

## TRUTRAC HI-HAT



EHH-2  
TRUTRAC HI-HAT



The TruTrac hi-hat is designed to replicate the look and feel of its acoustic counterpart. It follows a traditional approach mounting on any acoustic hi-hat stand. The TruTrac Hi-Hat uses top and bottom cymbals with full motion for a natural playing experience. When combined with the Redbox sound module, it produces sounds from open to closed, half-open and three quarter positions plus "chik" and splash. Pearl designed the TruTrac Hi-Hat to be the perfect upgrade for E Pro Live and the TruTrac Pad conversion kits.

# PRO SERIES

AS SIMPLE AS CHANGING A DRUM HEAD



(Also available with brass cymbals)

EPADRBM-25S

## TRU TRAC PACK + DRUMHEADS

Pearl's TruTrac Electronic Drumheads are available in pre-packs and individual components so you can convert your own acoustic kit into an electronic kit. Both pre-packs include (5) No Drill Adapters and all necessary parts and tools to complete your kit's conversion from acoustic to electronic. Connect the pads to your favorite module, Hi-Hat controller and cymbals to enhance your current electronic kit, and you're good to go!



TruTrac Pack Conversion Kits are available in two configurations: 10/12/16/14/Bass and 12/13/16/14/Bass.



No-Drill adapters connect through your air vent with no soldering or drilling required.



Insert the longer supplied tension rods into your existing hoops and tighten them just enough to secure the TruTrac Electronic Drumhead.



SSC924XUP/C389  
#389 MATTE LIQUID AMBER  
WITH EPADRBM-25S  
CONVERSION KIT

All of these great components couldn't reach their full potential without rich drum and percussion sounds generated from the r.e.d.box drum module (r.e.d. stands for Real Electronic Drums). The 128MB RAM capacity accommodates 1000 High Definition Sounds, 150 High Definition kits, plus space for 50 user-created kits.

r.e.d.box  
Real • Electronic • Drums



HIGH DEFINITION KITS  
JUST A CLICK AWAY.

One very unique and exciting capability of Pearl's r.e.d.box is the Memory Switch, which gives you the ability to flash the memory and substitute a lush, super high-end drum set for the original acoustics. Pearl has partnered with professional digital drum samplers Toontrack, Zildjian, and Steven Slate Drums, to provide the lush kits through [redboxsoundshop.com](http://redboxsoundshop.com).

RBM-20MUL  
r.e.d.box MODULE



**Pad & Cymbal Inputs**  
12 Dual-Zone trigger inputs for 24 unique sound sources

**MIDI IN/OUT**  
Connects with external MIDI device

**USB IN/OUT**  
Input for loading new sound sets from Mac or PC. Sends and receives MIDI

**AUX IN**  
Connects to external sound source

**AUX OUT**  
Connects to monitor system or recording device (sound assignable)

**MAIN OUT**  
Connects to amplifier or speaker system (sound assignable)

RedBox 2.0 firmware updates provide an enhanced dynamic range and sensitivity to give drummers the expression needed to appreciate the nuances of the lightest ghost notes and softest buzz rolls on stage or in the studio. Every kit has been modified to use the pitch-to-velocity function which allows samples to change in pitch when played at different velocities, creating a more realistic performance and reducing the unwanted triggering that is evident in most modules. E-Pro Live now supports the addition of 2 extra crash cymbals which require no additional programming when inserted to trigger inputs #10 and #11. Additional improvements have been made on the panning, EQ, and effects to provide the highest quality sonorities for recording or live performances. The fifty new kits run the gamut from Acoustic, One man Rhythm Sections and Hybrid Electronic. The red box now has 150 kits and is the largest library available in a drum module.

### MEMORY SWITCH

One of the most unique features of the r.e.d.box module is the ability to flash the memory of the module and replace the Original Acoustics with one large and lush-sounding kit. Just follow these easy steps and you'll be on your way to playing premium kits on your E-Pro Live from the best drum sampling software companies in the world!

1. Visit [redboxsoundshop.com](http://redboxsoundshop.com) to preview and purchase specially designed kits from Zildjian, Toontrack, Steven Slate, and Pearl and download the free software that allows your PC or Mac to communicate with the r.e.d.box.
2. Connect your computer to the r.e.d.box with a USB cable.
3. Launch the Memory Switch communication software and move the Original Acoustics to your computer.
4. Using a Mac, drag and drop the Lush kit onto the r.e.d.box icon which loads in 20 minutes. (Separate instructions required for PC)
5. Reverse the process to replace the original acoustics.
6. Free samples of lush sounding kits and drumless play-a-long tracks are available at [redboxsoundshop.com](http://redboxsoundshop.com).

Pearl's Precision Drum Monitors are a closed dynamic headphone of exceptional quality suitable for the most demanding professional applications. Based on the highly acclaimed Beyer Dynamic DT770 Pro, Pearl's PDM250 has been custom engineered as the ultimate drum monitoring headphone for recording studios, post production, or broadcasting situations.



Compatible with any electronic drum set and attachable to any throne. The Throne Thumper is equally at home vibing your kit's low frequencies to you as you practice, or letting you feel the bass player groove in a live show environment where hearing the other musicians is tough. Installation is easy and coupled with Pearl's Precision Drum Monitors, you'll hear every sonic nuance that your kit produces.



[redboxsoundshop.com](http://redboxsoundshop.com) offers the ultimate variety of high resolution kits ready for download. Play along mp3s are available in all genres as well as historical Pearl kits.



**VIRGIL DONATI**  
EDDIE JOHNSON / CAB / PLANET X

**ERIC SINGER**  
KISS / ALICE COOPER



**BRIAN FRASIER MOORE**  
JUSTIN TIMBERLAKE / MADONNA /  
CHRISTINA AGUILERA



**DENNIS CHAMBERS**  
SANTANA

**TERENCE HIGGINS**  
WARREN HAYNES / JOHN SCOFIELD



**NATE MORTON**  
THE VOICE

**TODD SUCHERMAN**  
STYX

**GEORGE KOLLIAS**  
NILE



**OMAR HAKIM**  
INDEPENDENT

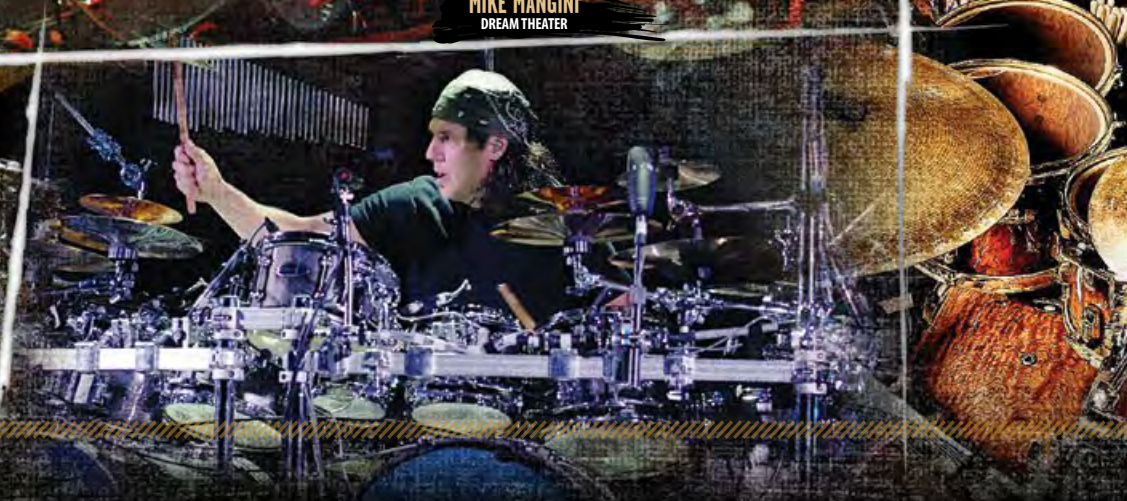

**MIKE MANGINI**  
DREAM THEATER



# REFERENCE SNARE DRUMS

THE ULTIMATE STABLE OF SNARES

MELVIN BALDWIN  
JUSTIN BIEBER

# MASTERS + SESSION SNARE DRUMS

CLASSIC PEARL SOUND



<b>RFP-1465S/C</b>	SIZE 14" x 6.5"
SHELL	6 ply: Maple 4 +Birch 2
HOOPS	FatTone (FH1410/1410S)
LUGS	STL-65
TENSION RODS	SST-5047 Stainless Steel
STRAINER	SR-1000 Glide-Lock Strainer
SNARES	SN-1420D Ultra-Sound "D" type



<b>RFP-1450S/C</b>	SIZE 14" x 5"
SHELL	6 ply: Maple 4 +Birch 2
HOOPS	FatTone Hoops (FH1410/1410S)
LUGS	STL-55L
TENSION RODS	SST-5047 Stainless Steel
STRAINER	SR-1000 Glide-Lock Strainer
SNARES	SN-1420D Ultra-Sound "D" type



<b>RFP-1365S/C</b>	SIZE 13" x 6.5"
SHELL	6 ply: Maple 4 +Birch 2
HOOPS	FatTone Hoops (FH1308/1308S)
LUGS	STL-65
TENSION RODS	SST-5047 Stainless Steel
STRAINER	SR-1000 Glide-Lock Strainer
SNARES	SN-1320D Ultra-Sound "D" type



<b>MMP-1455S</b>	SIZE 14" x 5.5"
SHELL	4 ply Maple*
HOOPS	MasterCast (DC1410/1410S)
LUGS	STL-55
TENSION RODS	SST-5055 Stainless Steel
STRAINER	SR-017
SNARES	S-022N



<b>MPL-1455S/C</b>	SIZE 14" x 5.5"
SHELL	6 ply Maple 5.4 mm
HOOPS	FatTone (FH1410/1410S)
LUGS	STL-55
TENSION RODS	SST-5055 Stainless Steel
STRAINER	SR-017
SNARES	S-022N



<b>BCX-1455S/C</b>	SIZE 14" x 5.5"
SHELL	6 ply Birch or Maple (MCX-1455S/C)
HOOPS	MasterCast (DC1410/1410S)
LUGS	CL-55
TENSION RODS	T-062
STRAINER	SR-017
SNARES	S-022N



<b>RF-1465S</b>	SIZE 14" x 6.5"
SHELL	20 ply: Maple 14+Birch 6
HOOPS	MasterCast (DC1410/1410S)
LUGS	BRL-65
TENSION RODS	SST-5047 Stainless Steel
STRAINER	SR-1000 Glide-Lock Strainer
SNARES	SN-1420D Ultra Sound "D" type



<b>RF-1450S</b>	SIZE 14" x 5"
SHELL	20 ply: Maple 14+Birch 6
HOOPS	MasterCast (DC1410/1410S)
LUGS	BRL-55
TENSION RODS	SST-5047 Stainless Steel
STRAINER	SR-1000 Glide-Lock Strainer
SNARES	SN-1420D Ultra Sound "D" type



<b>RF-1365S</b>	SIZE 13" x 6.5"
SHELL	20 ply: Maple 14+Birch 6
HOOPS	MasterCast (DC1306/1306S)
LUGS	BRL-65
TENSION RODS	SST-5047 Stainless Steel
STRAINER	SR-1000 Glide-Lock Strainer
SNARES	SN-1320D Ultra Sound "D" type



<b>MMP-1465S</b>	SIZE 14" x 6.5"
SHELL	4 ply Maple*
HOOPS	MasterCast (DC1410/1410S)
LUGS	STL-65
TENSION RODS	SST-5047 Stainless Steel
STRAINER	SR-017
SNARES	S-022N



<b>MPL-1465S/C</b>	SIZE 14" x 6.5"
SHELL	6 ply Maple 5.4 mm
HOOPS	FatTone (FH1410/1410S)
LUGS	STL-65
TENSION RODS	SST-5047 Stainless Steel
STRAINER	SR-017
SNARES	S-022N



<b>MCX-1465S/C</b>	SIZE 14" x 6.5"
SHELL	6 ply Maple or Birch (BCX-1465S/C)
HOOPS	MasterCast (DC1410/1410S)
LUGS	CL-65
TENSION RODS	T-061L
STRAINER	SR-017
SNARES	S-022N

\* w/ 4-ply Maple Reinforcement Rings



<b>RFB-1465</b>	SIZE 14" x 6.5"
SHELL	3mm Brass
HOOPS	MasterCast (DC1410/1410S)
LUGS	BRL-65
TENSION RODS	SST-5047 Stainless Steel
STRAINER	SR-1000 Glide-Lock Strainer
SNARES	SN-1420D Ultra-Sound "D" type



<b>RFB-1450</b>	SIZE 14" x 5"
SHELL	3mm Brass
HOOPS	MasterCast (DC1410/1410S)
LUGS	BRL-55
TENSION RODS	SST-5047 Stainless Steel
STRAINER	SR-1000 Glide-Lock Strainer
SNARES	SN-1420D Ultra-Sound "D" type



<b>RFS-1465</b>	SIZE 14" x 6.5"
SHELL	2.5mm Cast Steel
HOOPS	MasterCast (DC1410/1410S)
LUGS	BRL-65
TENSION RODS	SST-5047 Stainless Steel
STRAINER	SR-1000 Glide-Lock Strainer
SNARES	SN-1420D Ultra-Sound "D" type



<b>RFS-1450</b>	SIZE 14" x 5"
SHELL	2.5mm Cast Steel
HOOPS	MasterCast (DC1410/1410S)
LUGS	BRL-55
TENSION RODS	SST-5047 Stainless Steel
STRAINER	SR-1000 Glide-Lock Strainer
SNARES	SN-1420D Ultra-Sound "D" type



<b>SSC-1455S/C</b>	SIZE 14" x 5"
SHELL	6 ply 7.5mm Birch/Kapur
HOOPS	SuperHoop II (SH1410B/1410S)
LUGS	CL-55
TENSION RODS	T-062
STRAINER	SR-017
SNARES	S-022N



<b>SSC-1465S/C</b>	SIZE 14" x 6.5"
SHELL	6 ply 7.5mm Birch/Kapur
HOOPS	SuperHoop II (SH1410B/1410S)
LUGS	CL-65
TENSION RODS	T-061L
STRAINER	SR-017
SNARES	S-022N

# FREE FLOATING SNARE DRUMS

THE ULTIMATE PURITY OF SOUND



**Task-Specific Innovation** Just as each player has an individual voice, snare drums speak differently depending on shell type, size, weight, and application. With the latest Free Floating snare models, Pearl's engineers crafted each to fit a specific task by model. By combining the tonal character of each shell type with its ideally-matched depth - and adding different Ultra-Sound snare wires to further sculpt individual tonal personality - these Task-Specific Free Floating snares give the player a unique voice for any sonic situation.



**Click-Lock Throw-Off System** Featured on all new Free Floating snare models, the Click Lock Throw-Off is engineered with Polymer bearings for precise and smooth action. The unique nylon grip mechanism locks the snares into place at the top position, and disengages quickly when released. (Patent Pending)



30 years ago, Pearl introduced the Free Floating Snare Drum. A milestone achievement in snare drum evolution, this unique system removes all hardware from the shell to greatly improve the drum's resonance and projection.

With new sizes and shell types, today's Free Floating snare models are tailored to bring power, clarity, and true articulation to fit nearly any playing environment; and advance the instrument even further for a new breed of players.



• Deep, rich snare power with short, even sustain decay.  
**FTAL-1480** SIZE 14" x 8"  
 SHELL 1.2mm Seamless Aluminum  
 HOOPS MasterCast (DC1410/DC1410S)  
 LUGS FT-80  
 TENSION RODS SST-5042  
 STRAINER SR-160F  
 SNARES SN-1442C



• Ultimate in throaty, deep snare growl. Shortened decay.  
**FTMH-1480** SIZE 14" x 8"  
 SHELL 8 ply (10mm) African Mahogany  
 HOOPS MasterCast (DC1410/DC1410S)  
 LUGS FT-80  
 TENSION RODS SST-5042  
 STRAINER SR-160F  
 SNARES SN-1442C



• Lower overtone body, preserves crisp top-end snare snap.  
**FTBP-1465** SIZE 14" x 6.5"  
 SHELL 1.2mm Phosphor Bronze  
 HOOPS MasterCast (DC1410/DC1410S)  
 LUGS FT-65  
 TENSION RODS SST-5042  
 STRAINER SR-160F  
 SNARES SN-1420C



• Full-spectrum, both bright in punch and warm in tone.  
**FTBR-1450** SIZE 14" x 5"  
 SHELL 1mm Brass  
 HOOPS MasterCast (DC1410/DC1410S)  
 LUGS FT-50  
 TENSION RODS SST-5042  
 STRAINER SR-160F  
 SNARES SN-1420I



• 1mm shell for bright, open attack with ringy overtone.  
**FTSS-1435** SIZE 14" x 3.5"  
 SHELL 1mm Stainless Steel  
 HOOPS MasterCast (DC1410/DC1410S)  
 LUGS FT-35  
 TENSION RODS SST-5035  
 STRAINER SR-160F  
 SNARES SN-1420D



• Full, rounded bottom frequencies. Extra midrange body.  
**FTMMH-1465** SIZE 14" x 6.5"  
 SHELL 6 ply (7.5mm)\*  
 HOOPS MasterCast (DC1410/DC1410S)  
 LUGS FT-65  
 TENSION RODS SST-5042  
 STRAINER SR-160F  
 SNARES SN-1420C



• Punchy and smooth. A perfect "go-to" snare.  
**FTMM-1450** SIZE 14" x 5"  
 SHELL 6 ply (7.5mm) Maple  
 HOOPS MasterCast (DC1410/DC1410S)  
 LUGS FT-50  
 TENSION RODS SST-5042  
 STRAINER SR-160F  
 SNARES SN-1420I



• Dense all Birch shell delivers bright, open attack.  
**FTBB-1435** SIZE 14" x 3.5"  
 SHELL 6 ply (5.4mm) Birch  
 HOOPS MasterCast (DC1410/DC1410S)  
 LUGS FT-35  
 TENSION RODS SST-5035  
 STRAINER SR-160F  
 SNARES SN-1420D

\*4 ply Maple w/ 2 ply inner African Mahogany

# HYBRID EXOTIC SNARE DRUMS

SPACE-AGE PRECISION, TIMELESS TONE.



To capture sonic perfection for true professional, Pearl's latest experiments with different material combinations have yielded new tonal frontiers in our new Hybrid Exotic Series snare drums. The purest representation of Pearl's finest craftsmanship, Hybrid Exotic shell choices include spun-composite VectorCast™, dual-step seamless Cast Aluminum, and cross-laminated Kapur and Fiberglass, for the ultimate in power and prestige.



**Introducing VectorCast™** A single tiny strand can make all the difference in the world. Beginning with a composite material filament and resin thread, Pearl's new VectorCast shell is formed around a mandrel in an X-pattern; creating a thin, high-strength shell that "flexes" with each strike. Its characteristic sound is both lively and fat, and is a vast departure from other synthetics like Acrylic or Carbon Fiber.



**Glide-Lock Throw-Off System** Pearl's SR-1000 Glide-Lock Strainer's locking throw-off lever and tension knob assures worry free, slip-free performance from all Hybrid Exotic Snare Drums. (US Patent #7220905, #7301087, #7365256.)



**NEW Spin-Tight™ Tension Rods** To maintain tuning tension across the batter head, all Hybrid Exotic snare drums feature Pearl's new Spin-Tight tension rods. This elegantly simple innovation creates a tension rod-within-a-tension rod, that allows the rod to expand and lock into place without the swivel nut. Utilizing a special drum key, tunings can be controlled under high-impact play like never before. (Patent Pending)



• Quick, yielding snap with heavy midrange overtones.  
**HEP-1450** SIZE 14" x 5"  
 SHELL VectorCast  
 HOOPS SuperHoop II (SH1410B/1410S)  
 LUGS STL-100  
 TENSION RODS SPT-5047 (top) - SST-5047 (bottom)  
 STRAINER SR-1000  
 SNARES SN-1420C



• Full-Spectrum snare body with thick bottom-end tonality.  
**HEP-1465** SIZE 14" x 6.5"  
 SHELL VectorCast  
 HOOPS SuperHoop II (SH1410B/1410S)  
 LUGS STL-100  
 TENSION RODS SPT-5047 (top) - SST-5047 (bottom)  
 STRAINER SR-1000  
 SNARES SN-1420C



• Dry, high-pitched crack with little overtone.  
**HEAL-1450** SIZE 14" x 5"  
 SHELL Cast Aluminum: 3mm w/ 2mm R-Rings  
 HOOPS SuperHoop II (SH1410B/1410S)  
 LUGS STL-100  
 TENSION RODS SPT-5047 (top) - SST-5047 (bottom)  
 STRAINER SR-1000  
 SNARES SN-1420I



• Fat midrange focus without sacrificing volume.  
**HEAL-1465** SIZE 14" x 6.5"  
 SHELL Cast Aluminum: 3mm w/ 2mm R-Rings  
 HOOPS SuperHoop II (SH1410B/1410S)  
 LUGS STL-100  
 TENSION RODS SPT-5047 (top) - SST-5047 (bottom)  
 STRAINER SR-1000  
 SNARES SN-1420I



• Articulate snare punch, best at higher tunings.  
**HEK-1450** SIZE 14" x 5"  
 SHELL 6 ply 7.5mm Kapur w/Inner Fiberglass  
 HOOPS SuperHoop II (SH1410B/1410S)  
 LUGS STL-100  
 TENSION RODS SPT-5047 (top) - SST-5047 (bottom)  
 STRAINER SR-1000  
 SNARES SN-1420D



• A lively blend of throaty snare holler and punchy projection.  
**HEK-1465** SIZE 14" x 6.5"  
 SHELL 6 ply 7.5mm Kapur w/Inner Fiberglass  
 HOOPS SuperHoop II (SH1410B/1410S)  
 LUGS STL-100  
 TENSION RODS SPT-5047 (top) - SST-5047 (bottom)  
 STRAINER SR-1000  
 SNARES SN-1420D



• Low, thunderous wallop with deep, solid playability.  
**HEK-1480** SIZE 14" x 8"  
 SHELL 6 ply 7.5mm Kapur w/Inner Fiberglass  
 HOOPS SuperHoop II (SH1410B/1410S)  
 LUGS STL-100  
 TENSION RODS SPT-5047 (top) - SST-5047 (bottom)  
 STRAINER SR-1000  
 SNARES SN-1442D

# SENSITONE SNARE DRUMS

CLASSIC, RELIABLE SNARE POWER

The Sensi Tone sound is a necessity. Vital, immediate snare tone that has recalls the chart-topping legends of yesterday, but with a undeniably modern sensibility. Classic beaded shells in Steel, Nickel-Plated Brass, and Seamless Aluminum deliver the goods, and the right gig-ready touches make them utility standards for the power player.



• Crisp, sensitive high-pitched snap.

<b>STA-1450S</b>	<b>SIZE 14" x 5"</b>
SHELL	1mm Beaded Steel
HOOPS	SuperHoop II (SH1410B/1410S)
LUGS	TB-55
TENSION RODS	SST-5047
STRAINER	SR-150
SNARES	SN-1420I



• Perfect blend of attack and brassy body.

<b>STA-1450BR</b>	<b>SIZE 14" x 5"</b>
SHELL	1mm Beaded Brass
HOOPS	SuperHoop II (SH1410B/1410S)
LUGS	TB-55
TENSION RODS	SST-5047
STRAINER	SR-150
SNARES	SN-1420I



• Dry, focused crack with quick decay.

<b>STA-1450AL</b>	<b>SIZE 14" x 5"</b>
SHELL	1.2mm Beaded Seamless Aluminum
HOOPS	SuperHoop II (SH1410B/1410S)
LUGS	TB-55
TENSION RODS	SST-5047
STRAINER	SR-150
SNARES	SN-1420I



• Belting crack with mild midrange overtone.

<b>STA-1465S</b>	<b>SIZE 14" x 6.5"</b>
SHELL	1mm Beaded Steel
HOOPS	SuperHoop II (SH1410B/1410S)
LUGS	TB-65
TENSION RODS	SST-5047
STRAINER	SR-150
SNARES	SN-1420I



• An elegant solution for punch and warmth.

<b>STA-1465BR</b>	<b>SIZE 14" x 6.5"</b>
SHELL	1mm Beaded Brass
HOOPS	SuperHoop II (SH1410B/1410S)
LUGS	TB-65
TENSION RODS	SST-5047
STRAINER	SR-150
SNARES	SN-1420I



• Full, guttural snare bellow with little overtone.

<b>STA-1465AL</b>	<b>SIZE 14" x 6.5"</b>
SHELL	1.2mm Beaded Seamless Aluminum
HOOPS	SuperHoop II (SH1410B/1410S)
LUGS	TB-65
TENSION RODS	SST-5047
STRAINER	SR-150
SNARES	SN-1420I

### Throw-Off System: SR-150 Strainer

The secret behind Pearl's new patent pending Click-Lock Strainer System is a "C"-shape clip that clicks onto the tension dial. This prevents the lever from disengaging, and the tension dial from loosening, even if the tension is very low. A Polymer bearing on the axle provides smooth and accurate action, and reliably quick response from the lever.

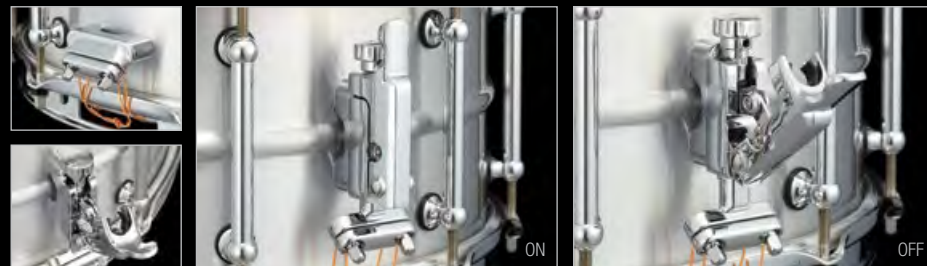

# SENSITONE PREMIUM SNARE DRUMS

IMMACULATE PERCUSSION



• Bright and responsive with lively overtone.

<b>STA-1450FB</b>	<b>SIZE 14" x 5"</b>
SHELL	1.5mm Beaded Brass
HOOPS	SuperHoop II (SH1410B/1410S)
LUGS	ARL-55
TENSION RODS	SST-5047
STRAINER	SR-150
SNARES	SN-1420I



• Bold projection with controlled ring sustain.

<b>STA-1465FB</b>	<b>SIZE 14" x 6.5"</b>
SHELL	1.5mm Beaded Brass
HOOPS	SuperHoop II (SH1410B/1410S)
LUGS	ARL-65
TENSION RODS	SST-5047
STRAINER	SR-150
SNARES	SN-1420I



• Musical and penetrating with mid-range power.

<b>STA-1450PB</b>	<b>SIZE 14" x 5"</b>
SHELL	1.2mm Phosphor Bronze
HOOPS	SuperHoop II (SH1410B/1410S)
LUGS	ARL-55
TENSION RODS	SST-5047
STRAINER	SR-150
SNARES	SN-1420I



• Bellowing low-end whallop with smooth articulation.

<b>STA-1465PB</b>	<b>SIZE 14" x 6.5"</b>
SHELL	1.2mm Phosphor Bronze
HOOPS	SuperHoop II (SH1410B/1410S)
LUGS	ARL-65
TENSION RODS	SST-5047
STRAINER	SR-150
SNARES	SN-1420I



• Top-end projection with fat highs and mids.

<b>STA-1450MM</b>	<b>SIZE 14" x 5"</b>
SHELL	6 ply 5.4mm Maple
HOOPS	SuperHoop II (SH1410B/1410S)
LUGS	ARL-55
TENSION RODS	SST-5047
STRAINER	SR-150
SNARES	SN-1420D



• Thick snare tone with suppressed mid-tonality.

<b>STA-1465MM</b>	<b>SIZE 14" x 6.5"</b>
SHELL	6 ply 5.4mm Maple
HOOPS	SuperHoop II (SH1410B/1410S)
LUGS	ARL-65
TENSION RODS	SST-5047
STRAINER	SR-150
SNARES	SN-1420D



• The Baritone Snare; low-end tone with top-end snap.

<b>STA-1550MH</b>	<b>SIZE 15" x 5"</b>
SHELL	4 ply 5mm African Mahogany*
HOOPS	SuperHoop II (SH1510B/1510S)
LUGS	ARL-55
TENSION RODS	SST-5047
STRAINER	SR-150
SNARES	SN-1520I

### Sensi Tone Premium

Engineered for performance perfection, Sensi Tone Premium snare drums feature a choice of Patina Beaded Brass, Beaded Phosphor Bronze, or even-ply North American Maple shells. With 14" models available in 5" and 6.5" depths, the Premium line's newcomer is the new African Mahogany 15"x5" Baritone snare model, adding an additional voice to the tonal pallet.

Sensi Tone Premium's selection of refined percussion instruments truly demand a place of prestige, and are sure to be first-call drums for the stage, studio, and beyond.



Pearl's stylish new Arch-Tube Lugs come standard on all Sensi Tone Premium snares. The low-contact Arch casting includes two self-aligning swivel nuts rather than a contiguous tube. This allows for pristine tuning across the head and reduced margin for binding within the lug.



# SIGNATURE SNARE DRUMS

CAPTURE THE ELUSIVE SOUND OF YOUR DRUMMING IDOL



**DENNIS CHAMBERS**



<b>DC-1465</b>	<b>SIZE 14" x 6.5"</b>
SHELL	4 Ply Maple Shell w/ Reinforcement Rings
HOOPS	MasterCast (DC1410/1410S)
LUGS	CL-100
RODS	10
TENSION RODS	SST-5047 Stainless Steel
STRAINER	SR-020 on both side (4-way adjustable)
SNARES	S-030N
FINISH	#136 Opal White



**CHAD SMITH**



<b>CS-1450</b>	<b>SIZE 14" x 5"</b>
SHELL	Steel Shell
HOOPS	SuperHoop II (SH1410B/1410S)
LUGS	CL-55
RODS	10
TENSION RODS	SST-5047 Stainless Steel
STRAINER	SR-018
SNARES	S-022
FINISH	Black Nickel



**IAN PAICE**



<b>IP-1465</b>	<b>SIZE 14" x 6.5"</b>
SHELL	Beaded Steel Shell
HOOPS	SuperHoop II (SH1410B/1410S)
LUGS	TB-65
RODS	10
TENSION RODS	SST-5042 Stainless Steel
STRAINER	SR-017
SNARES	S-022
FINISH	Steel



**JOEY JORDISON**



<b>JJ-1365</b>	<b>SIZE 13" x 6.5"</b>
SHELL	Steel Shell
HOOPS	SuperHoop II (SHB1308/1308S)
LUGS	CL-65B
RODS	8
TENSION RODS	SST-5047 Stainless Steel
STRAINER	SR-017
SNARES	S-029N
FINISH	Custom Black



**VIRGIL DONATI**



<b>VG-1450</b>	<b>SIZE 14" x 5"</b>
SHELL	8 ply* (Outer 4 ply Maple / Inner 4 ply Birch)
HOOPS	MasterCast (DC1410/1410S)
LUGS	TB-50
RODS	10
TENSION RODS	SST-5042 Stainless Steel
STRAINER	SR-017
SNARES	S-022N
FINISH	#188 Smoke Flake



**OMAR HAKIM**



<b>OH-135</b>	<b>SIZE 13" x 5"</b>
SHELL	6 ply African Mahogany Shell
HOOPS	SuperHoop II (SH1308/1308S)
LUGS	CL-55
RODS	8
TENSION RODS	SST-5047 Stainless Steel
STRAINER	SR-015
SNARES	S-029N
FINISH	#140 Natural Mahogany

# EFFECT SNARE DRUMS

VERSATILE DRUMS FOR SECONDARY EFFECTS.

FIRECRACKER



<b>FCP-1250</b>	<b>SIZE 12" x 5"</b>
SHELL	8 ply Poplar
HOOPS	1.6mm Steel (RIM1206/1206SL)
LUGS	CL-50
RODS	6
TENSION RODS	T-062
STRAINER	SR-018
SNARES	S-031



<b>FCS-1050</b>	<b>SIZE 10" x 5"</b>
SHELL	1.0mm Steel
HOOPS	1.6mm Steel (RIM1006/1006SL)
LUGS	CL-50
RODS	6
TENSION RODS	T-062
STRAINER	SR-018
SNARES	S-032



<b>M-1060</b>	<b>SIZE 10" x 6"</b>
SHELL	6 ply Maple
HOOPS	SuperHoop II (SH1006/1006S)
LUGS	CL-65
RODS	6
TENSION RODS	SST-5035 Stainless Steel
STRAINER	SR-018
SNARES	S-032N



<b>M-1270</b>	<b>SIZE 12" x 7"</b>
SHELL	8 ply Maple
HOOPS	1.6mm Steel (RIM1208B/1208S)
LUGS	CL-100
RODS	8
TENSION RODS	SST-5047 Stainless Steel
STRAINER	SR-018
SNARES	S-031N

EFFECTS



<b>B-1330</b>	<b>SIZE 13" x 3"</b>
SHELL	Brass
HOOPS	1.6mm Steel (RIM1308B/1308S)
LUGS	CL-05
RODS	8
TENSION RODS	T-055
STRAINER	SR-018
SNARES	S-029N



<b>S-1330</b>	<b>SIZE 13" x 3"</b>
SHELL	Steel
HOOPS	1.6mm Steel (RIM1308B/1308S)
LUGS	CL-05
RODS	8
TENSION RODS	T-055
STRAINER	SR-018
SNARES	S-029N

PICCOLO



<b>M-1330</b>	<b>SIZE 13" x 3"</b>
SHELL	6 ply Maple
HOOPS	1.6mm Steel (RIM1308B/1308S)
LUGS	CL-05
RODS	8
TENSION RODS	T-055
STRAINER	SR-018
SNARES	S-029N



The compact SR-018 Strainer features direct-pull geometry for crisp and articulate snare response.



# DEMON DRIVE / CHAIN DRUM PEDALS

THE FASTEST, SMOOTHEST, MOST POWERFUL PEDAL IN THE WORLD.



- P-3000D: Single Pedal Complete
- P-3002D: Double Pedal Complete (right footed)
- P-3001D: Double Pedal Conversion Kit (right footed)
- P-3002DL: Double Pedal Complete (left footed)



BEATER HEIGHT ADJUSTMENT

PERFECT CIRCLE CAM

PIVOTING HOOP CLAMP

MULTI FUNCTION DRUM KEY

DIRECT LINK ADJUSTMENT

NINJA BEARINGS

CONTROL CORE BEATERS

A choice of 2 positions for a finesse or power feel. Simply loosen the clamshell to change position. U.S. Patent #7579540



INDEPENDENT BEATER ANGLE AND FOOTBOARD HEIGHT ADJUSTMENTS

ADJUSTABLE TRACTION PLATE

DUO-DECK FOOTBOARD

## DEMON CHAIN

TRADITIONAL FEEL & POWER OF A CHAIN

The Demon Chain pedal combines all of the innovative features of the Demon Drive pedal with all the power, speed, and traditional feel that so many players demand. The Perfect Circle cam provides a smooth consistent response throughout the entire range of the stroke for pinpoint accuracy and control. If you demand the feel of a chain drive in a high performance package, take the Demon out for a test drive.

- P-3000C: Single Pedal Complete
- P-3002C: Double Pedal Complete (right footed)
- P-3001C: Double Pedal Conversion Kit (right footed)
- P-3002CL: Double Pedal Complete (left footed)

P-3000C (shown in longboard set up)

## DEMON DRIVE

UNLEASH THE DEMON

The Demon Drive is without a doubt the most thoroughly engineered bass drum pedal the World has ever seen. Lightning fast power and silky smooth finesse make this the choice of some of the most prolific drummers in the world. An amazing array of adjustable features turns this pedal into an extension of your body. From beater angle, traction plate grip, and footboard height and angle, it's all your choice. And when you feel the need for speed the Demon quickly converts to a double pedal with a simple add on pack. Unleash the Demon and find out what custom feel is all about.



The Click-Lock prevents the tension knob from loosening no matter how hard you play. Simply flip up for adjustment. US Patent # 7754953

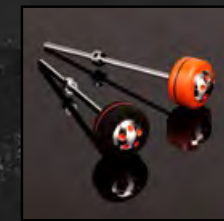

The Demon Drive beater features a Control Core elastomer center that eliminates unwanted vibration. US Patent # 7626108



The most unique feature of the Demon Drive pedal is Pearl's exclusive Duo-Deck Footboard, the world's first convertible footboard. Through a simple adjustment, the footboard can be adjusted from a traditional shortboard to a longboard pedal in seconds, offering a slightly lighter, quicker feel that is the preferred setup when speed is a necessity. U.S. Patent #7626107



The NINJA Bearings were originally designed by skateboarding engineers. These bearings feature micro-polished steel balls for amazing speed and incredible smoothness.



The two position Direct Link adjusts for a choice of light or heavy feel. This creates the most seamless link between the player's musical ideas and their execution on a bass drum.

P-3002D Direct Drive Double Pedal (shown in longboard setting)



P-3002C Chain Drive Double Pedal (shown in shortboard setting)



The Z-Link Drive Shaft features Pearl's exclusive Zero Latency Universal Joints that use precision radial ball bearings and hand-assembled CNC machined frames for zero play and smoothness that allows your slave pedal to respond as quickly and precisely as your primary.



The "linear-response" Perfect Circle Cam provides consistent and smooth feel throughout the entire stroke for pinpoint accuracy and superb control. The racing-inspired Cam is designed to minimize mass and maximize speed and power transfer.



The Demon Chain Pedal is driven by the ultra-lightweight Power Chain with low-friction rollers for speed, and double chain construction for power and dependability. The orange anodized link plates identify the Demon Chain as a member of the Demon family of pedals.

# ELIMINATOR DRUM PEDAL

YOUR FEET WON'T FAIL YOU NOW

## QUADBEATER • U.S. Patent # 5610351

Our QuadBeater provides four different beater surfaces, each with its own distinct sound. You can choose from 2 hard plastic surfaces or 2 felt surfaces and either pinpoint or line contact with the head.

## INDEPENDENT TRACTION GRIPS

PowerShifter Eliminator's Traction Plate footboard insert allows you to remove and reconfigure each individual traction grip to suit your exact playing requirements. From maximum grip to full slide, and every option in between, the choice is yours. The Traction Plate also reverses to focus the slide or grip surfaces to either the toe or heel of the pedal.

## ZERO PLAY HINGE • U.S. Patent # 7179978

Our stainless steel hinge is manufactured with incredibly precise tolerances to prevent play between the footboard and heel yet provides maximum freedom of motion for blazing speed.



## SIDE MOUNT HOOP CLAMP

U.S. Patent # 5726370

Easy access to clamp makes adjustments super easy.



P-2000C: Chain Drive Single Pedal Complete  
P-2000B: Belt Drive Single Pedal Complete

P-2002C: Chain Drive Double Pedal Complete  
P-2001C: Chain Drive Double Pedal Conversion Kit (right footed)

P-2002CL: Chain Drive Double Pedal Complete (left footed)

P-2002B: Belt Drive Double Pedal Complete  
P-2001B: Belt Drive Double Pedal Conversion Kit (right footed)  
P-2002BL: Belt Drive Double Pedal Complete (left footed)



## CONVERSION KIT

The P-2001 Conversion Kit converts single Eliminator pedals into a double. Your existing single pedal becomes the left auxiliary pedal.

- P-2001C Chain Drive w/Case
- P-2001B Belt Drive w/Case

(right footed only)



P-2000C  
CHAIN DRIVE



P-2000B  
BELT DRIVE



## CHAIN DRIVE

Pearl's sprocket-less double chain drive provides super smooth action with powerful and precise feel. Since there are no teeth, the "grinding" noise common with most chain drive pedals is eliminated making the Eliminator perfect for studio work.

## BELT DRIVE

Our Belt Drive provides a very comfortable, natural feel similar to a direct drive system. We use an extremely strong, highly durable drive belt, instead of a normal nylon strap, to provide maximum durability, strength, and stretch resistance.

## POWERSHIFTER FUNCTION

Our revolutionary PowerShifter function provides 3 positions to fine tune the power and feel of the pedal. By moving the footboard forward or back, you change the chain or belt drive angle, thus changing the leverage to create a light, regular, or strong feel. U.S. Patent #5574237

## PowerShifter ELIMINATOR

## INTERCHANGEABLE CAM SYSTEM U.S.PAT.#6172291

Our exclusive Cam System provides six (4 included + optional 2) interchangeable color coded cams allowing you to quickly change the power and feel of the pedal to suit your individual playing needs. Changing from cam to cam is as simple as pushing the release button and snapping another cam in place.

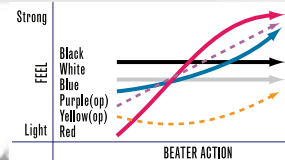

# P-930 DRUM PEDAL

SPEED & CONTROL FOR THE MASSES

Pearl's P-930 merges many of the advanced features of our Flagship Demon Drive with our Award winning Eliminator line to create a bass drum pedal never before available in this price range. High end performance inspired from our Demon Drive like the longboard footboard, Control Core beater and our Click-Lock spring tension keepers combine with our PowerShifter and Eliminator style cam technology that uses our Perfect Circle cam with a removable Orange Progressive Cam for fully tunable performance and lightning speed and control.

If you want fast feet and you're on a budget, Pearl's P-930 is the ultimate pedal to step up to.

## CONTROL CORE DUO BEATER

U.S. Patent #7626108

Our Control Core Beater utilizes our Control Core elastomer center to minimize vibration. It features 2 unique striking surfaces, a slightly rounded felt and a slightly convex hard plastic surface.

## POWERSHIFTER FUNCTION

U.S. Patent #5574237

Our PowerShifter function provides 2 positions to fine tune the power and feel of the pedal. By moving the footboard forward or back, you change the chain angle, thus changing the leverage to create a light, or strong feel.

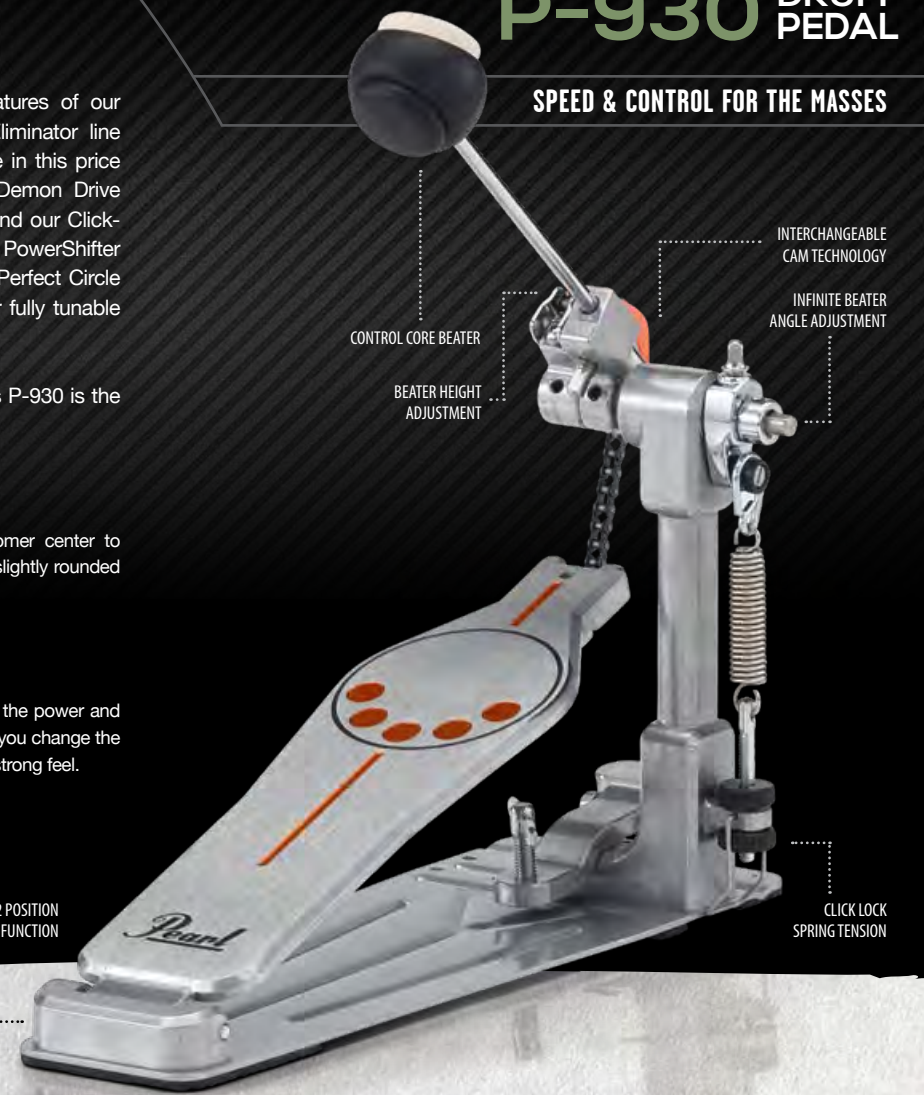

- P-930: Single Pedal Complete
- P-932: Double Pedal Complete (right footed)
- P-931: Double Pedal Conversion Kit (right footed)
- P-932L: Double Pedal Complete (left footed)



What's better than double the speed, power and control of our P-930? Nothing. The P-932 Demon Deuce gives the gift of amazing feet for a fraction of the cost of other "less innovative" pedals.



The Orange Progressive Cam can be removed to reveal the Perfect Circle for further tunability to match your playing style. U.S. Patent #6172291

Click-Lock spring tension maintains perfect tension gig after gig. Set it and forget it. U.S. Patent #7754953

# HI-HAT STANDS

THE BIGGEST ADVANCEMENT IN TIME KEEPING SINCE THE WRISTWATCH.



The H-2000 features our slip-proof Super Grip Clutch with patented lock nut. The pivoting seat cup provides a stable platform for the bottom cymbal for improved control and consistency.

U.S. Patent #7326843 & #7078606

The H-2000 Precision Spring Tension Dial allows absolute perfect tension control for the ultimate in fine-tunable response.



ZERO PLAY HINGE  
U.S. Patent # 7179978

Like all Eliminators, the pedal has removable traction grip inserts that can be adjusted or removed to tailor the amount of grip or slip. The plate is even reversible for more choices.



HA-130

The HA-130 positions your hi-hat next to your bass pedal in double bass set-ups for super quick transitions between pedals.

## H-2000

- SuperGrip Clutch (U.S. Patent #7326843)
- Hi-Hat Cup (U.S. Patent #7078606)
- Swiveling Legs
- Precision Spring Tension Dial
- PosiLink Twin Cam Drive System with Interchangeable Cams (U.S. Patent #6399866)
- Traction Plate Footboard
- Convertible Spike/Rubber Feet (U.S. Patent #7371953)
- Footboard Docking Station (U.S. Patent #7371952)
- PowerShifter

## RH-2000

- SuperGrip Clutch (U.S. Patent #7326843)
- Hi-hat Cup (U.S. Patent #7078606)
- Precision Spring Tension Dial
- PosiLink Twin Cam Drive System with Interchangeable Cams (U.S. Patent #6399866)
- Traction Plate Footboard
- Reversible Spike/Rubber Feet
- PowerShifter
- Drop Clutch Included

## H-1000

- Direct Pull Drive System
- Infinitely Adjustable Footboard Angle
- Double Braced Tripod w/ Swivel Function
- Spike/Rubber Tips
- Clutch w/Lock Nut (U.S. Patent #7326843)
- Spring Tension Dial
- Hi-hat Cup (U.S. Patent #7078606)

## H-930

- Direct Pull Drive System
- Precision Spring Tension Dial
- Double Braced Tripod w/ Swivel Function
- SureGrip Oversize Rubber Feet
- Demon Style Long Board Footboard

## H-830

- Demon Style Long Footboard (single color footboard)
- Double Braced Tripod w/ Swivel Function

## CLH-930

- Closed Hi-Hat
- Uni-Lock Tilter
- Knurled Boom Arm
- UltraGrip Wing Nuts / Wing Bolts



1000 Series Pedal Height Adjustment

H-930 Hi-Hat Stand

H-830 Hi-Hat Stand

The 2000 Series shares many of the key characteristics of its sibling, the Eliminator drum pedal, including the Interchangeable Cam System, the first of its kind on any hi-hat stands. The whole concept of the Eliminator system creates an experience of unmatched versatility and responsive action. The customizable footboard with full control over slip and grip allows the Eliminator to adapt to your style of playing like no other hi-hat stands you have ever played.

The RH-2000 Remote Hat combines the H-2000 Eliminator Hi-Hat stand's PosiLink Twin Cam drive system with a third-generation low-friction cable to produce the smoothest, lightning-fast, natural feeling remote hat in the world. Teamed with our ICON Rack System, the RH-2000 can be placed virtually anywhere or facilitate multiple hi-hat setups.



The H-1000 features our infinitely adjustable footboard angle adjustment. This allows precise height matching when using multiple pedal setups.



H-1000 Hi-Hat Stand uses beefy 1" tubing and clamshell clamps with built in memory locks for superior rigidity.

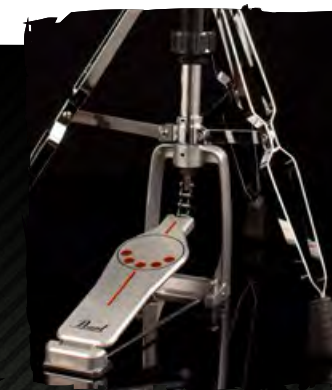

H-930 Hi-Hat Stand features our Demon style longboard, double braced tripod w/swivel function, and precision tension dial.



H-830 Hi-Hat Stand is standard equipment with our Export series and offers a monochromatic Demon Style longboard design and swivel tripod.

# SNARE STANDS

EVERY SNARE SHOULD BE SO LUCKY.

Every gig is different, and so is every snare drum. But no matter the gig or the snare drum we have a stand to accommodate both.

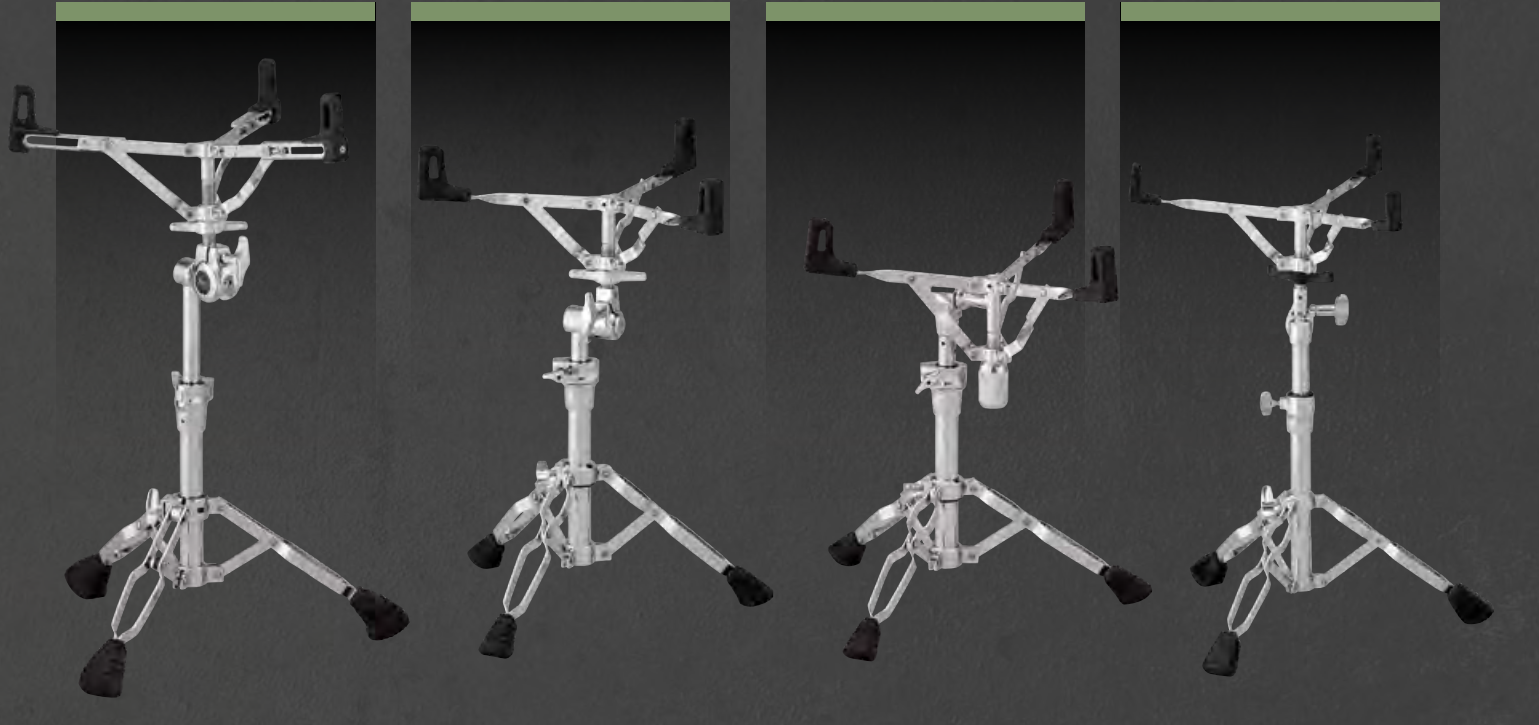

## S-1030

- GyroLock tilter
- Air suspension Rubber Tips (U.S. Patent #6710236)
- Trident Tripod
- Oversize super grip rubber feet
- Fits snares 10"-16"
- Height range of 470-660mm

## S-930

- Uni-Lock tilter
- Air suspension Rubber Tips (U.S. Patent #6710236)
- Double braced Trident Style tripod
- Fits snares 10"-14"
- Height range of 450-630mm

## S-930D

- Drop Basket for deeper snares
- Uni-Lock tilter
- Air suspension Rubber Tips (U.S. Patent #6710236)
- Double braced Trident Style tripod
- Fits snares 10"-14"
- Height range of 360-540mm

## S-830

- Uni-Lock tilter
- Double braced tripod
- Fits snares 13"-14"
- Height range of 430-620mm

Our premiere S-1030 model offers chameleon like diversity for stage or studio. Rock solid footing with a GyroLock tilter that allows pinpoint positioning. The basket arms adjust to fit snares from 10" to 16" while promoting optimal resonance with its Air Suspension cradle.

The S-930 offers similar features but uses our legendary Uni-Lock tilter and is also available as a drop basket version.

Our S-830 model is standard equipment with our all new Export line. Lightweight, yet rigidly strong, it's perfect for the local gig and makes load in at the club a breeze.



### S-1030 SNARE STAND GYROLOCK

Our premier S-1030 model features Pearl's 360 degree infinitely adjustable GyroLock tilter for ease-of-use and pinpoint positioning.



### S-1030 SNARE BASKET

The Pearl S-1030 Snare Stand adjusts to fit virtually any size snare from 10" to 16". The Air Suspension rubber tips securely cradle your prized snares while allowing them to fully resonate. U.S. Patent #6710236



### SPIKED / RUBBER FEET

Our CVT-300/3 Push Button Spiked/Rubber Feet come in pack of 3 to retrofit on any of our 1030 Series hardware for sure-footed performance on any terrain. U.S. Patent #7371953



### S-930D SNARE BASKET

The S-930D Snare Stand is a shorter version of the S-930 Snare Stand, and is built to comfortably accommodate deeper snare drums.

# DRUM THRONES

SOUND ERGONOMICS.

Next to your drums your throne could be your most important piece of gear. A great throne will prevent fatigue, promote great form and posture to keep you going for those second and third encores night after night. Our thrones offer advanced ergonomic design, sturdy wide footprints for stability and a wide selection of cushion tops to provide your desired level of softness or firmness.



D-1000SN (Not shown)  
Same as below but in a "short" version 455-625mm

## D-2500BR

- Motorcycle-style cushion
- Detachable backrest mounts via single knob
- Reversible Stoplock collar
- Height range of 495-665mm

## D-1000SPN

- Round vinyl cushion
- Built in shock absorber post with adjustable spring tension
- Reversible stoplock
- Height range of 525-630mm

## D-1000N

- Round vinyl cushion
- Reversible stoplock
- Height range of 495-665mm



D-2500 and D-1000 Series Thrones are equipped with Pearl's exclusive Lock/Spin System. By reversing the StopLock, the cushion can be locked to prevent turning or allowed to spin depending on your preference.



The D-1000SPN Series features a firm vinyl covered cushion and a shock absorbing post for outstanding comfort, along with adjustable spring tension for customizable support.



## D-2500

- Motorcycle-style cushion
- Accepts backrest
- Reversible Stoplock collar
- Height range of 495-665mm

## D-930

- Round vinyl cushion
- Double braced legs
- Height range of 470-660mm

## D-790

- Round vinyl cushion
- Height range of 450-650mm

## D-730S

- Round vinyl cushion
- Single braced tripod
- Height range of 400-580mm



The Height Collar features a hinged Stop Lock and vise-like clamshell design for non-slip security.

# BOOM + STRAIGHT CYMBAL STANDS

WELCOME TO BOOM TOWN.

Pearl's BC-2030 features patent pending Nodal Point Markings on the telescopic tubes that allow cymbals to achieve better clarity and sustain when the tubes are positioned at their respective Nodal Points.



## BC-2030

- GyroLock Tilter
- WingLoc
- Reversible Cup Washer w/O-ring
- Die Cast Joint w/Stop Lock
- Trident Tripod
- Double Braced Legs
- Built in Percussion Post
- Nodal Point Resonance Enhancing System (Patent Pending)



## BC-1030

- GyroLock Tilter
- WingLoc
- Reversible Cup Washer w/O-ring
- Die Cast Joint
- Trident Tripod
- Double Braced Legs
- Built in Percussion Post

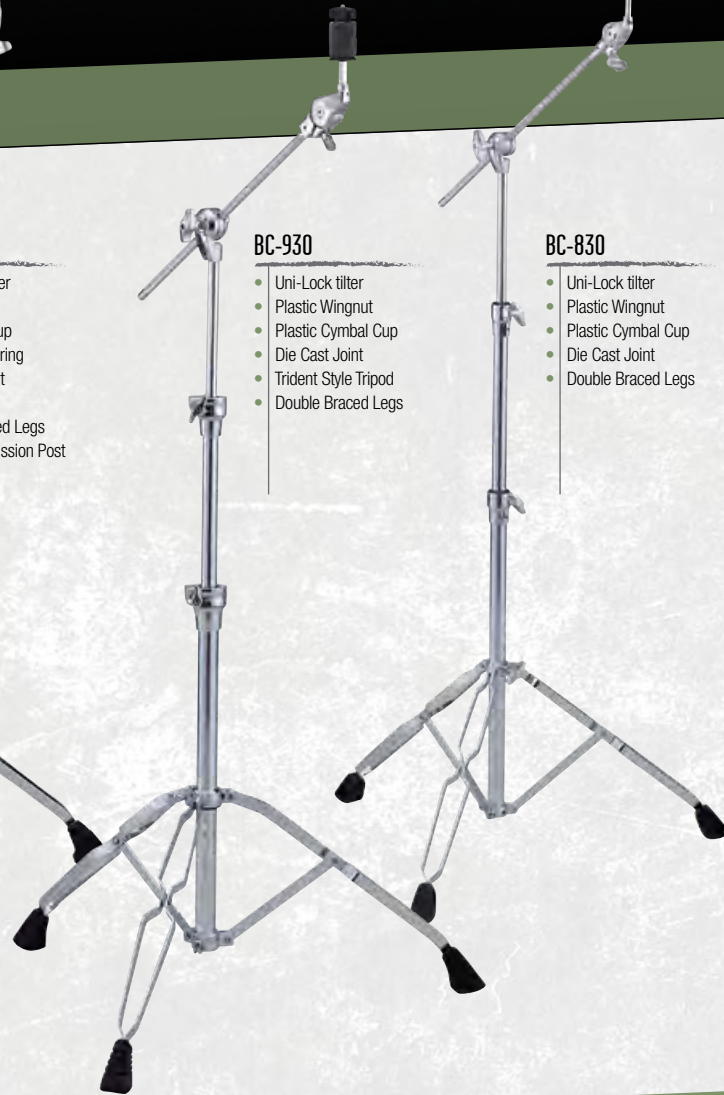

## BC-930

- Uni-Lock tilter
- Plastic Wingnut
- Plastic Cymbal Cup
- Die Cast Joint
- Trident Style Tripod
- Double Braced Legs



## BC-830

- Uni-Lock tilter
- Plastic Wingnut
- Plastic Cymbal Cup
- Die Cast Joint
- Double Braced Legs



## C-1030

- GyroLock Tilter
- WingLoc
- Reversible Cup Washer w/O-ring
- Die Cast Joint
- Trident Tripod
- Double Braced Legs
- Built in Percussion Post



## C-930

- Uni-Lock Tilter
- Plastic Wingnut
- Plastic Cymbal Cup
- Die Cast Joint
- Trident Style Tripod
- Double Braced Legs
- Built in Percussion Post



## C-830

- Uni-Lock Tilter
- Plastic Wingnut
- Plastic Cymbal Cup
- Die Cast Joint
- Double Braced Legs



IAN PAICE  
DEEP PURPLE

## FOR EVERY CYMBAL, THERE IS A PLACE.

Nothing takes more abuse than your cymbal stands.

Constant practice, tear 'em down throw 'em in the back of your ride, load 'em in at the gig. Abuse 'em a couple of hours on stage then start all over again. Those clamps and tilters take a lot of abuse that's why Pearl is the choice of the serious working drummer. We've been advancing drum hardware since 1946 so if you're serious about drumming, get serious about your hardware.

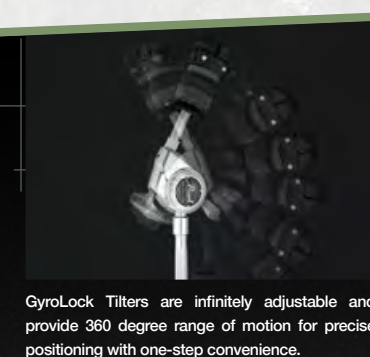

GyroLock Tilters are infinitely adjustable and provide 360 degree range of motion for precise positioning with one-step convenience.



**WingLoc (U.S. Patent # 6884015)**  
Pearl's WingLoc Quick Release Wing Nut snaps open and snaps closed for super quick removal and attachment.

**Reversible Seat Cup (U.S. Patent #6940006)**  
The seat cup is specially designed to "float" normally or it can be reversed and "locked" to prevent noise during recording.



The Trident Tripod uses a full 360° of clamping force via the hinged collar. The inner tube rests in a nylon bushing to prevent metal to metal contact. Heavy duty legs feature lateral bracing for superior ultra quiet rigidity.



The C-830 offers lighter weight while incorporating many of the 1030 series designs. The tripod uses Trident style design with double braced legs. Large easy to use wingnuts and lateral struts for optimal stability.

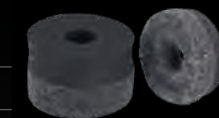

The Reversible Felt/Foam Cymbal Washers allow four-way control of cymbal "ring" by mixing and matching the "hard" and "soft" surfaces of the washers.

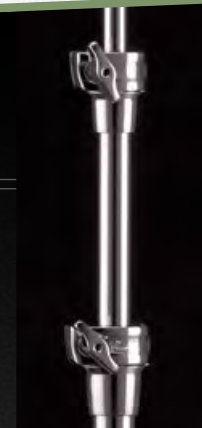

The Clamshell designed Die Cast joint on 2030, 1030, 930 series Boom and Straight cymbal stands, provides superhuman clamping force. Set your position, lock it down and wail away.

# RACKS + TOM STANDS / ARMS

AN INDUSTRY ICON - THE PROFESSIONAL'S CHOICE.

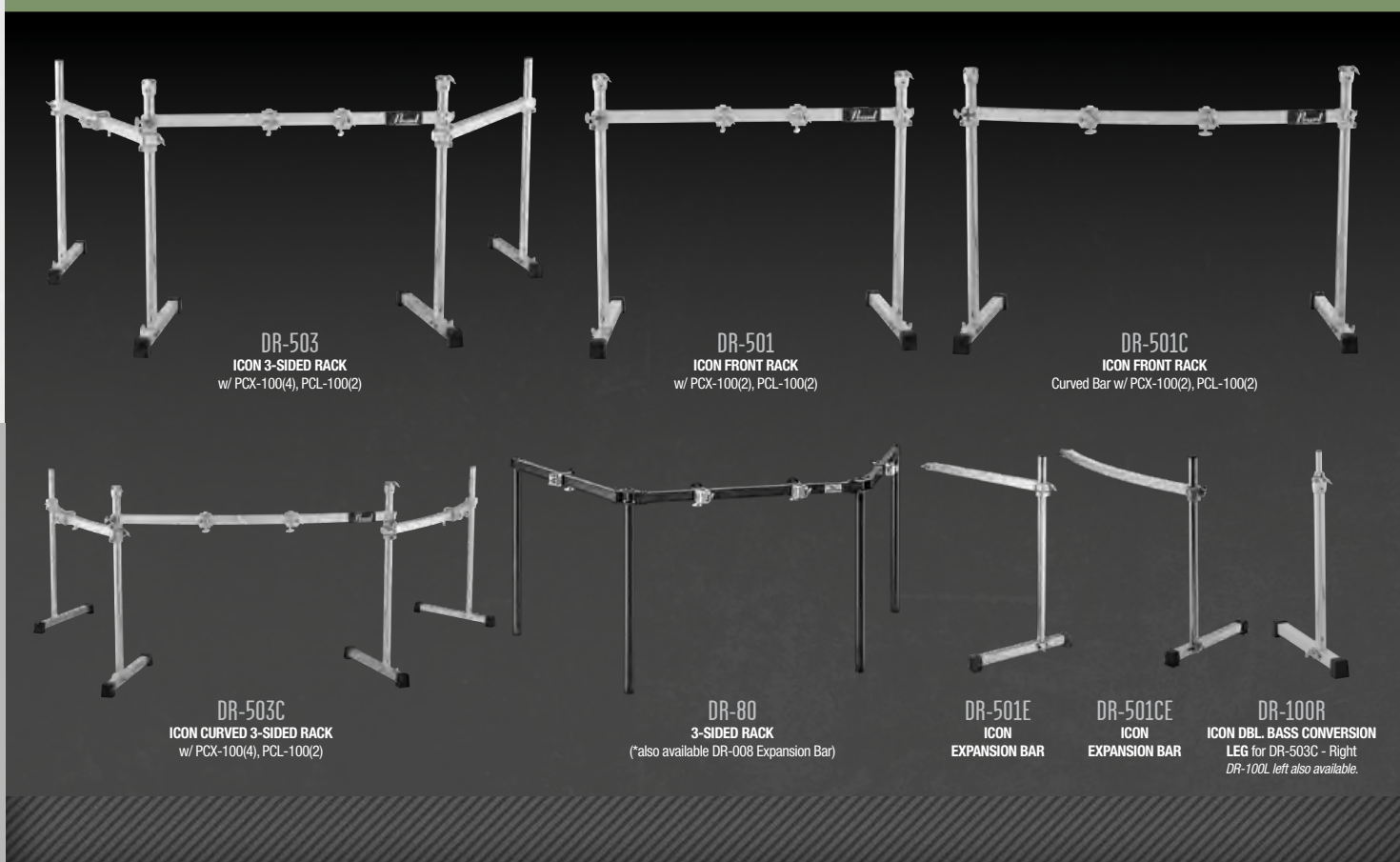

**DR-503**  
ICON 3-SIDED RACK  
w/ PCX-100(4), PCL-100(2)

**DR-501**  
ICON FRONT RACK  
w/ PCX-100(2), PCL-100(2)

**DR-501C**  
ICON FRONT RACK  
Curved Bar w/ PCX-100(2), PCL-100(2)

**DR-503C**  
ICON CURVED 3-SIDED RACK  
w/ PCX-100(4), PCL-100(2)

**DR-80**  
3-SIDED RACK  
(\*also available DR-008 Expansion Bar)

**DR-501E**  
ICON  
EXPANSION BAR

**DR-501CE**  
ICON  
EXPANSION BAR

**DR-100R**  
ICON DBL. BASS CONVERSION  
LEG for DR-503C - Right  
DR-100L left also available.



T-1030

T-930

TC-1030

TC-930

CH-1030

CH-930

CH-830

CH-70



**PMBDL3C**  
CHROME MULTI BASS DRUM LEGS

Multi-Bass Drum Legs allow any bass drum to be played horizontally. Height and tilt adjustable.



TH-1030 TOM ARMS



GYROLOCK

UNI-LOCK

GEAR TILTER

Pearl's Tom Arms offer positioning possibilities never before attainable. Our T/TC-1030 Series features our GyroLock tilter for an infinite 360 degree range of movement. The T/TC-930 Series use our Uni-Lock tilter for 180 degrees of motion. Our TH-88 and TH-70 Tom Arms Series use our dependable gear tilter.

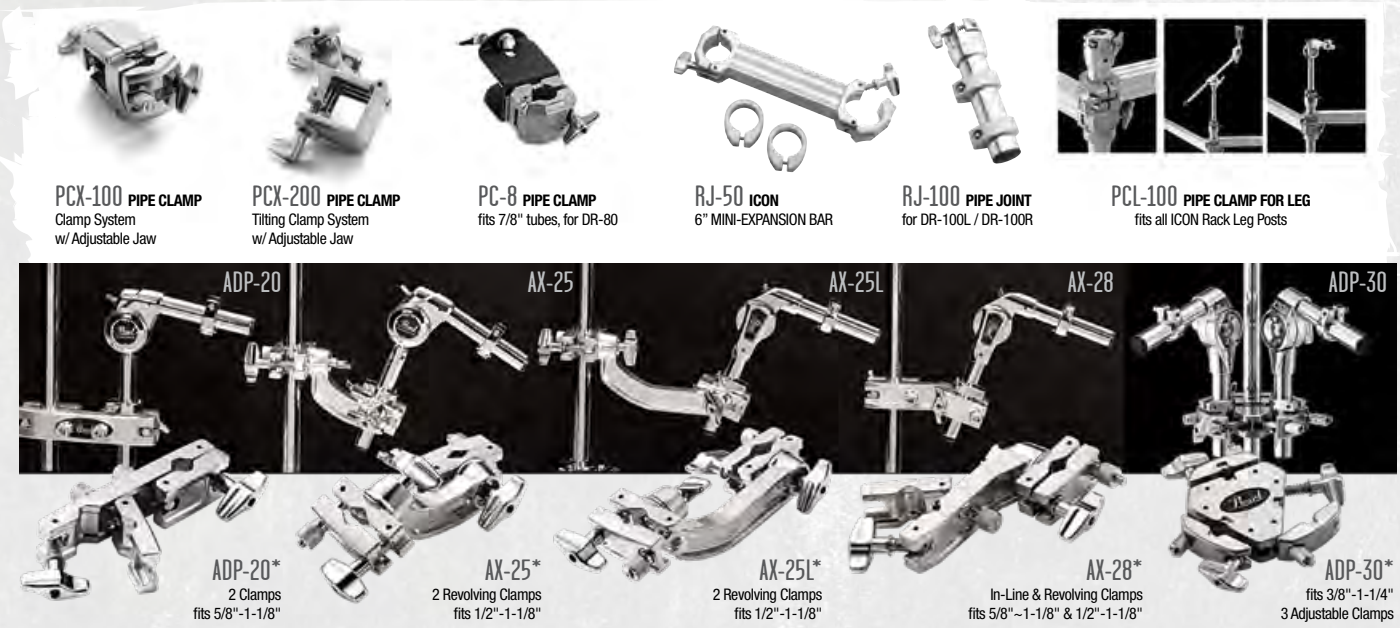

**PCX-100** PIPE CLAMP  
Clamp System  
w/ Adjustable Jaw

**PCX-200** PIPE CLAMP  
Tilting Clamp System  
w/ Adjustable Jaw

**PC-8** PIPE CLAMP  
fits 7/8" tubes, for DR-80

**RJ-50** ICON  
6" MINI-EXPANSION BAR

**RJ-100** PIPE JOINT  
for DR-100L / DR-100R

**PCL-100** PIPE CLAMP FOR LEG  
fits all ICON Rack Leg Posts

**ADP-20\***  
2 Clamps  
fits 5/8"-1-1/8"

**AX-25\***  
2 Revolving Clamps  
fits 1/2"-1-1/8"

**AX-25L\***  
2 Revolving Clamps  
fits 1/2"-1-1/8"

**AX-28\***  
In-Line & Revolving Clamps  
fits 5/8"-1-1/8" & 1/2"-1-1/8"

**ADP-30\***  
fits 3/8"-1-1/4"  
3 Adjustable Clamps

\*Stands & Tom Arms not included

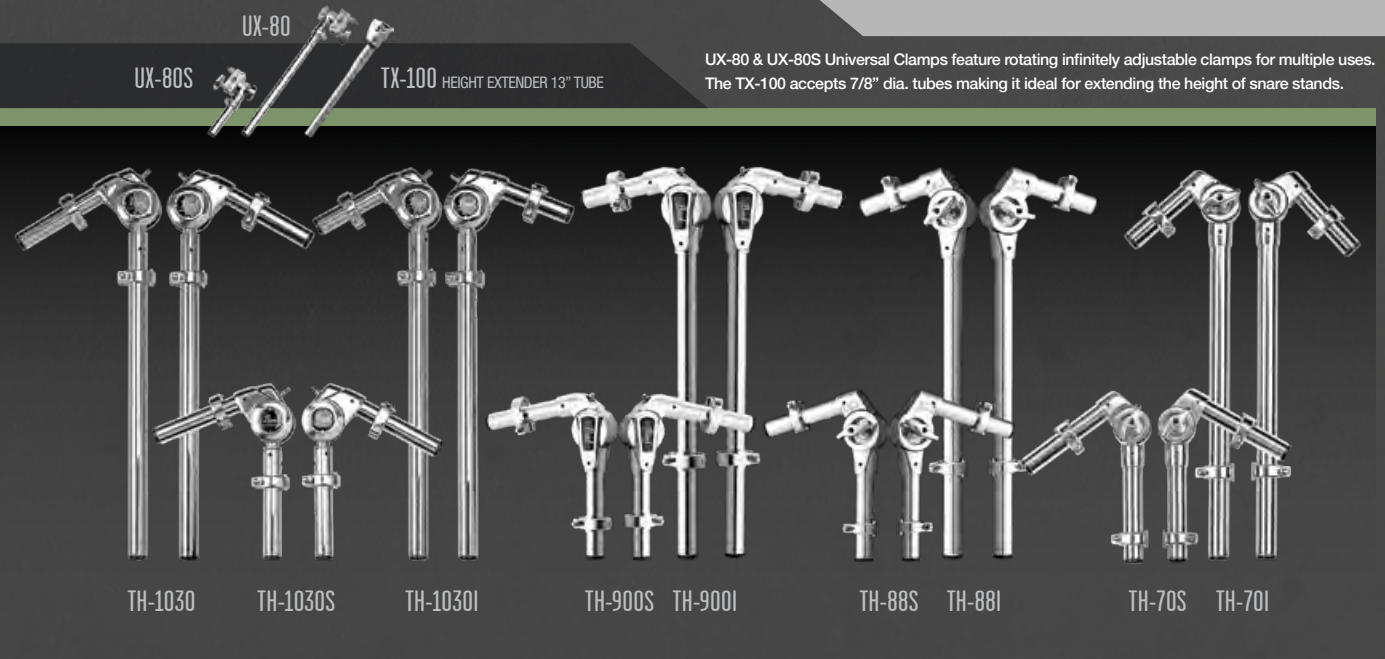

UX-80S

UX-80

TX-100 HEIGHT EXTENDER 13" TUBE

UX-80 & UX-80S Universal Clamps feature rotating infinitely adjustable clamps for multiple uses. The TX-100 accepts 7/8" dia. tubes making it ideal for extending the height of snare stands.

TH-1030

TH-1030S

TH-1030I

TH-900S

TH-900I

TH-88S

TH-88I

TH-70S

TH-70I

# SIGNATURE CONGAS + BONGOS

THE PROS PLAY PEARL!

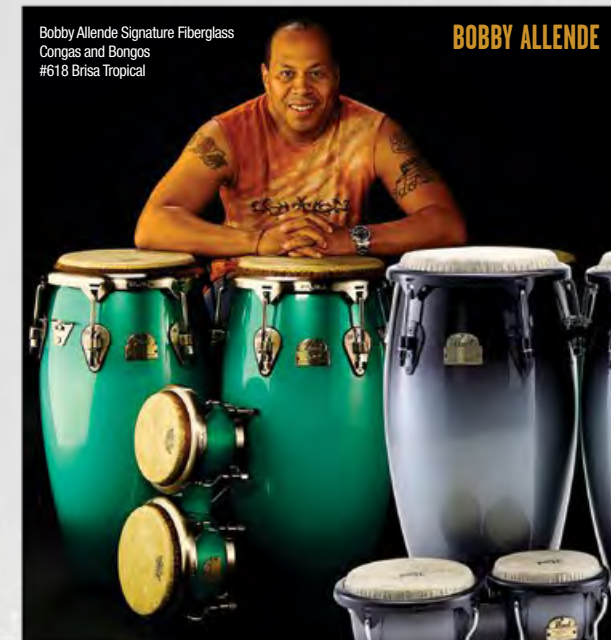

Bobby Allende Signature Fiberglass Congas and Bongos #618 Brisa Tropical

**BOBBY ALLENDE**

**CONGAS**  
PCF-110DXBA 11" QUINTO  
PCF-117DXBA 11.75" CONGA  
PCF-125DXBA 12.5" TUMBA  
**BONGOS**  
PBF-300DXBA 7" & 8.5"

**BOBBY ALLENDE PRIMERO MODEL**  
#642 Harbor Gray  
PFC-202BA 10" & 11" CONGAS  
PFB-100BA 7" & 8.5" BONGOS  
*(not available in Europe)*



**ELITE FIBERGLASS CONGAS**  
PCF-110DXA 11" QUINTO  
PCF-117DXA 11.75" CONGA  
PCF-125DXA 12.5" TUMBA  
#641 Blue Sparkle Burst

**ELITE FIBERGLASS BONGOS**  
PBF-300DXA 7" & 9"  
#641 Blue Sparkle Burst

## PEARL CONGAS

Pearl has congas to meet the needs of every player from seasoned professionals to beginners. Our Elite Series offers the highest quality heads with polished Contour Crowns and a choice of shell materials: 100% aged Thai Oak or seamless Fiberglass. Our Primero Pro line features professional-quality construction at an affordable price and a choice of 100% Thai Oak or Fiberglass. The Primero line features outstanding Pearl quality along with the same choice of 100% Thai Oak or Fiberglass. Both series offer matching bongos to perfectly compliment your ensemble. Pearl's Signature Congas feature Contour Crown Rims, polished chrome hardware, and exclusive Self-Aligning Washer System for truly optimal performance. Each series is offered with matching Bongos, and is available in 100% Thai Oak or seamless Fiberglass shells.



**RICHIE FLORES**

Richie Flores Signature Oak Congas and Bongos #527 Lunar Eclipse

**RICHIE FLORES PRIMERO MODEL**  
#534 Tiburon Blue  
Wide Body Shape  
PWC-202RF 10" & 11" CONGAS  
PWB-100RF 7" & 8.5" BONGOS  
*(not available in Europe)*

**CONGAS**  
PCM-110DXRF 11" QUINTO  
PCM-117DXRF 11.75" CONGA  
PCM-125DXRF 12.5" TUMBA  
**BONGOS**  
PBW-300DXRF 7" & 9"

## HAVANA SERIES

The new Havana Series congas and bongos combine Cuban tradition with superior craftsmanship.

The wide belly shape of these high end, fiberglass drums produce deeper low tones and greater volume. Contour Crown rims and natural skin heads give you clear highs and cutting slaps. The stunning Liquid Gold finish and chrome plated hardware completes a set of drums you can love forever.

### HAVANA CONGAS

PCF110HV644 11" Havana Quinto  
PCF117HV644 11.75" Havana Conga  
PCF125HV644 12.5" Havana Tumba

### HAVANA BONGOS

PBF300HV644 7" & 9" Havana Bongos  
#644 Liquid Gold



**ELITE OAK BONGOS**  
PBW-300DX 7" & 9"  
#532 Cherry Eucalyptus

**ELITE OAK CONGAS**  
PCW-110DX 11" QUINTO  
PCW-117DX 11.75" CONGA  
PCW-125DX 12.5" TUMBA  
#532 Cherry Eucalyptus

## TRAVEL CONGAS

Pearl Travel Congas are available in three standard sizes: 11"x3.5", 11.75"x3.5" and 12.5"x3.5". They feature wood shells and stave construction and Remo FiberSkyn 3 synthetic heads. Five precision Allen bolts provide accurate and easy tuning via the included foam-handle wrench. The Travel Conga stand is designed specifically to be rock solid, and lightning fast during set-up and pack-up. The stand comes with a carrying bag that includes a pocket for the optional PPS-50TC Bridge that connects two stands together to minimize creeping while performing.



PTC-1100 11" TRAVEL CONGA  
PTC-1175 11.75" TRAVEL CONGA  
PTC-1125 12.5" TRAVEL CONGA  
PSC-1175TC Travel Conga Bag

PC-1100TC STAND FOR 11" w/ CARRYING BAG  
PC-1175TC STAND FOR 11.75" w/ CARRYING BAG  
PC-1125TC STAND FOR 12" w/ CARRYING BAG  
PPS-50TC STAND BRIDGE



**TRILOK GURTU**  
INDEPENDENT

**FRANK KNUCKLES**  
THE ROOTS

**LALO DAVILA**  
MTSU

**PAPU PEPIN**  
CONGA LEGEND

**ROLANDO MORALES MATOS**  
THE LION KING

**ANDY FARAG**  
UMPHREYS MCGEE

**BRETT BAKER**  
JAY-Z



**COUNT M'BUTO**  
THE DEREK TRUCKS BAND

**ARCHIE PEÑA**  
SHAKIRA

**CESAR ESPINOZA**  
ORCHESTRA TOBACO Y RON

**VALERIE DEE NARANJO**  
SATURDAY NIGHT LIVE

**CARMELO TORRES**  
LOS LONELY BOYS

**AARON DRAPER**  
JILL SCOTT / COMMON

**RICHARD BRAVO**  
LOS TEMERARIOS



# CAJONS & ACCESSORIES

GET IN THE CAJON ZONE!



Cajons are the perfect introduction to the world of percussion. Affordable, easy to carry and just plain fun to play. Pearl offers a diverse collection of Cajons with a complete selection of accessories to customize your instrument and develop your own unique sound. Perfect for drum circles, small gigs or even studio work, your Cajon will become your new best friend.



**SONIC BOOM BUZZ\***  
PBC-1914SBS

Sister to the popular Sonic Boom, the Buzz adds fixed snares and a resonant Artisan Walnut front plate. This beautiful cajon really has the deep bass and punchy snare crack you need to emulate a drum set.



**CYCLONE CAJON**  
PCJ-647CVC

When you hit this rounded back, fiberglass beauty and the air funnels around and exits the bass port resulting in a fat, throaty bottom. The flexible wood faceplate provides a crisply articulate voice with remarkable projection.



**INNER CIRCLE MULTI DRUM CAJON**  
PCJ-IC

Sit on top for standard cajon playing, or unlatch, remove and place drum on the closed cajon and play like a conga at a seated height. Or attach the accompanying strap and you have a shoulder-stung djembe or Timbao. Awesome!



**CLUB CAJON\***  
PBC-5512CC

The Club cajon features all wood construction with fixed snares and a rear facing bass port that deepens the lows.

#512 Sheer Black finish



**PRIMERO JINGLE\***  
PBC-507JC

The Primero Jingle is a wood version of the Jingle cajon and features built in Platinela and tambourine jingles that allow you to sound like an entire percussion section.

#507 Gypsy Brown finish



**OG**  
SLIGHTLY STOOPID



**PETE KORPELA**  
THE LION KING



**JESUS DIAZ**  
INDEPENDENT / JESUS DIAZ & QBA



**SAMMY FIGUEROA**  
INDUSTRY LEGEND



**FAUSTO CUEVAS**  
STEVIE WONDER



**JESSIE CARABALLO**  
MARC ANTHONY



**CUBE CAJON**  
PFCC-629S

This 12.5" square Fiberglass cajon features 5 diverse playing surfaces and a built in port to boost lows. Each surface is a different thickness to vary the pitch. Stand included.

#629 Carubinga finish



**2 FACE CAJON**  
PBC-512TF

This professional wood cajon with fixed snares has a 3mm thick face for a traditional low pitch and a 5mm thick face for a distinct higher pitch.

#512 Sheer Black



**WEDGE TRI-SIDE CAJON**  
PCJ-3000B

This unique pie slice shape offers a natural seated playing position and 2 striking surfaces. Fiberglass construction with fixed snares and Artisan II finish. Ported in rear.



**BOOM BOX CAJON**  
PCJ-633BB

This Fiberglass cajon with fixed snares features a built in bass port that magnifies subsonic frequencies for great bass projection.

#633 Artisan Red Mahognay



**PRIMERO BOX CAJON\***  
PBC-507

Get started with Primero. Constructed from Asiatic Pine with snares, this model has the right pitch and price.

#507 Gypsy Brown finish



**BOOM BOX CAJON**  
PCJ-633BB630

This Fiberglass cajon with fixed snares features a built in bass port that magnifies subsonic frequencies for great bass projection.

#630 Red Sparkle



**BRUSH BEAT CAJON**  
PCJ-633BT

Fiberglass construction with textured surface that responds well to brushes and other effects. Ported in rear.

Black and White Finish



**FUN BOX CAJON**  
PFB-300

Help your child develop proper playing mechanics while playing this smaller kid-friendly size cajon. Durable Fiberglass construction finished in bright Yellow.



**CAJON STAND**  
PCJ-70STD

The Pearl Cajon Stand accepts virtually every make and model of cajon. The stand is fully height and angle adjustable and sets up in seconds. Four points of contact with the drum, double braced legs and large rubber feet provide maximum stability.



**SONIC BOOM\***  
PBC-1914SB

Made in the USA. A massive low-end producer perfect for small acoustic settings or larger amplified venues. 100% Birch construction provides exceptional resonance that speaks clearly through the frontward facing bass port. This Box Rocks!



**JESUS DIAZ SIGNATURE RADIAL EDGE CAJON**  
PBC-509JD

In conjunction with world-renowned percussionist Jesus Diaz, Pearl has created the Radial Edge Cajon. Its high-end wood construction, fixed snares and luxurious Artisan Rosewood finish make this the ultimate cajon experience possible.



**JINGLE CAJON**  
PCJ-629

Designed by Pete Korpela this Fiberglass cajon features built in Platinela and tambourine jingles that can be engaged for incredible sound with fixed snares.

#629 Carubinga finish

## CAJON ACCESSORIES

Pearl's line of cajon accessories allow you to enhance your performance by adding dynamic new sounds. Jingle Cups can be added to the face of any Cajon or even to acoustic guitars and other drums. The new Cajon Clave and Wood Blocks attach to your cajon using the provided 3M Dual-Lock Tape or can be played hand-held or stand mounted. The new Cajon seat cushion adds comfort for long sessions.



**CAJH-100**  
Cajon Holster  
Nylon w/ Velcro Straps



**PSC-BC**  
Seat Cushion w/  
Thick Foam for Comfort



**PBCW-100**  
Wood Block w/ Dual-Lock  
Tape & Mounting Bracket  
(PPS-37 Not Included)



**PJCP-1/6**  
Jingle Cup  
Two Pack

**PBCC-100**  
Clave Block w/ Dual-Lock  
Tape & Mounting Bracket  
(PPS-37 Not Included)

# TIMBALES + COWBELLS + FRAME DRUM PERCUSSION

BUILD THE RIGHT RIG FOR THE GIG!



MARC QUIÑONES  
ALLMAN BROTHERS BAND



HORACIO HERNANDEZ  
INDEPENDENT

## TIMBALES



PTS-5134  
PRIMERO TIMBALES  
13" / 14" Steel w/ Tilting Stand  
(Stands & Cowbell included)

PTE-1415DX  
PRIMERO PRO TIMBALES  
14" / 15" Steel w/ Tilting Stand  
(Sticks included. Not available in Europe)

PTB-5145  
ELITE TIMBALES  
14" / 15" Brass w/ Tilting Stand

ETE-1415MQ  
MARC QUIÑONES SIGNATURE TIMBALES  
14" / 15" Steel w/ Tilting Stand and  
PBL-30 Clave Block (Cowbell not included)

PTE-1415MQ  
MARC QUIÑONES SIGNATURE SERIES  
PRIMERO TIMBALES  
14"x7" / 15"x7" Steel Shells w/ Tilting Stand  
Black Powder Coat

## HORACIO HERNANDEZ SIGNATURE COWBELLS

## NEW YORKER BELLS

## BALA BELLS



HH-5X MARYBELL  
HH-4X ISABELL  
HH-3X CHABELLA  
HH-2X CLABELL  
HH-1X BELLA



BCM-3NY CHA-CHA (High)  
BCM-5NY CHA-CHA (Low)  
BCM-7NY MAMBO  
BCM-8NYQ MARC QUIÑONES SIG. TIMBALE BELL  
BCM-10 MOUNTED CAMPANA BELL  
BCM-10 HAND-HELD CAMPANA BELL



Pearl and Grammy Award winning artist Horacio Hernandez have developed the ultimate family of cowbells. These bells feature a quick release system that allows the bell to lift easily off of its mount for hand held playing. 5 unique pitches make this the perfect family.

## PRIMERO COWBELLS



PCB-1030 10" BELL w/ PPS-30  
PCB-6 6" BELL  
PCB-4 4" BELL



JOSE ROSA MIAMI INDEPENDENT  
SAMMY GARCIA INDEPENDENT  
MARCO "TITO" ARGUNZONI TITO NIEVES  
CARLITO SOTO WILLIE COLON



PTE-1336  
PRIMERO 13" STEEL TIMBALE  
w/ PPS-36 Mount

PTE-3131  
FLAT TIMBALE  
w/ I.S.S. (Steel)

PTB-3131  
FLAT TIMBALE  
w/ I.S.S. (Brass)



PTB-30 TRI-BELLS  
ECB-22 HAND-HELD AGOGO  
ECB-23 MOUNTED AGOGO  
PTA-30 TRI AGOGO  
PDC-60 PRO COWBELL BEATER

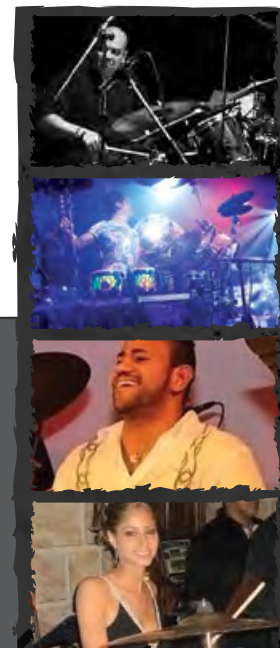

JOSE APONTE  
UNT

RAVI JAKHOTIA  
RAVI DRUMS

CHRISTIAN PEPIN  
INDEPENDENT

JESSICA RODRIGUEZ  
COCOMAMA



FRAME DRUMS • Pearl Frame Drums are solid wood construction with tuneable coated heads that allow you to create various tones.

RAFAEL PEREIRA  
JANELLE MONAE



PFR-14HK\*  
HIP KIT 14" Frame Drum  
w/ Hip Clipz Snare & Strap

The Pearl Hip Kit combines a 14" frame drum and accessory pack that is perfect for drum circles, the stage, studio or as a cocktail kit.



PFR-14C  
14" FRAME DRUM



PFR-0818C  
FRAME DRUMS Set of 6  
Sizes: 8", 10", 12", 14", 16", 18"

The Hip Clipz accessories can convert any frame drum into the ultimate wearable, go anywhere drum.

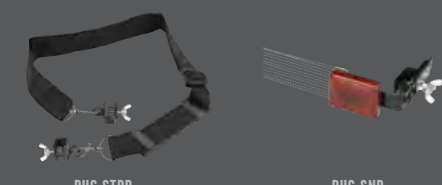

PHC-STRP HIP CLIPZ STRAP  
PHC-SNR HIP CLIPZ SNARE  
PHC-PK HIP CLIPZ PACK

# DJEMBES + FOLKLORIC PERCUSSION

ANCIENT INSTRUMENTS FOR THE MODERN PERCUSSIONIST.

**DJEMBES** • Djembes are a traditional African instrument that offer a wide variety of sounds and are perfect for drum circles. The Professional Elite Series is available in Oak (12.5" diameter) and Fiberglass (12.5" and 14" diameter). All feature our Contour Crowns for comfortable playing and authentic Goat skin heads for deep lows and crisps highs.



Pearl's EZ Tune Djembe is the first djembe ever to combine the traditional look and feel of a rope djembe with the modern functionality of a mechanical tuning system.



**PJW-140R533** EZ TUNE DJEMBE 14" (OAK) #533 Gloss Black  
**PJW-125R533** EZ TUNE DJEMBE 12.5" (OAK) #533 Gloss Black  
**PJF-320R632** EZ TUNE DJEMBE 12" (FIBERGLASS) #632 Cranberry Fade  
**PJF-350R632** EZ TUNE DJEMBE 14" (FIBERGLASS) #632 Cranberry Fade  
**PJW-340** ELITE OAK DJEMBE 12.5" #511 Natural (Not available in Europe)  
**PJF-350 14" / PJF-320 12.5"** ELITE FIBERGLASS DJEMBE #602 Bistre Black (Not available in Europe)  
**PFD-300** FIBERGLASS FUN DRUM

**DJEMBASS** • If you want extreme low-end, and a head-turning alternative to a standard bass drum, look no further than Pearl's Djembass. Convert our most popular PJF-350 Fiberglass Djembe into a compact kick drum with the Djembass accessory pack. To reduce the attack and add greater "lows" we have included a cloth cap that stretches around the head. For greater low-end, slip the included neoprene disc inside which give you two sound options. Your pedal (not included) attaches via an I.S.S. type clamp to the Djembe's stand mounting plate.



**PJBS-350** DJEMBASS



**CAMILO QUINONES** B-SIDE PLAYERS  
**DAVID PEREZ** JAZZ SPY  
**DIMAS SANCHEZ** RICO MONACO, IBA A SE  
**ERNESTO DIAZ** BERKLEE FACULTY  
**ETIENNE FUENTES** CHAYANNE  
**HECTOR "POCHO" MECOSUP** MIAMI INDEPENDENT  
**JOSE CLAUSSELL** EDDIE PALMIERI  
**JUAN PABLO ROMERO** OSCAR DE LEON  
**MARIO MONACO** INDEPENDENT  
**OHAR LEDEZMA** L.A. INDEPENDENT  
**PAPO RODRIGUEZ** JOHNNY POLANCO  
**ZIG MAJLER** HANDS ON WITH ZIG

**FOLKLORIC ELITE CONGAS** • Pearl's line of Folkloric congas feature a traditional look with modern innovation that only Pearl can deliver. Each 28" tall Oak conga is designed for the "seated" player, but is pre-drilled for stand mounts if necessary. Thicker South American style natural skins makes the drums warm sounding, but a fiberglass gel coat on the interior seals the shell and adds the projection and volume desired by today's players. Four Polished Steel Reinforcing Bands are inset on the shell for a smooth touch, and the traditional hoops complete these stunning instruments in a Matte Crimson Sunrise finish. The 7 & 8.5" Oak Bongos have the same hardware and shell features of the congas. The thicker bongo skins add to the projection and "dry" tone reminiscent of that classic Cuban sound.



**PCW-125FC** TUMBADOR 12.5"  
**PCW-110FC** QUNITO 11"  
**PCW-117FC** SEGUNDO 11.75"  
**PBW-300FC** FOLKLORIC ELITE BONGOS 7" & 8.5"



**PBA-60** ITOTELE  
**PBA-70** IYA  
**PBA-50** OCONCOLO

**BATAS** • Pearl Percussion Bata drums are available in Crimson Sunrise, the same beautiful finish featured on our Folkloric Elite congas and bongos. Additionally, the hardware is finished in Polished Steel and matches the hardware on our other tunable hand drums. These sacred ceremonial instruments have a thicker Enu (large) head for a deep, rich tone.

## SHEKERES



**PCA-14FC** CATA W/ HOLDER  
**PAC-10FC** ACHERE  
**PGT-10FC** GUATACA  
**PCL-10FCB** BAMBOO CLAVE  
**PCL-20FCW** WOOD CLAVE  
**PPS-45** SHEKER HOLDER  
**PSK-50FC** UNO  
**PSK-60FC** SEGUNDO  
**PSK-70FC** CAJA

# BRAZILIAN + CONCERT PERCUSSION

DISCOVER SAMBA!

## BRAZILIAN PERCUSSION

Pearl's line of Brazilian Percussion brings modern refinements and Pearl quality to the traditional Samba musician. Our Repinique features lightweight yet sturdy steel shells with etched heads, shoulder straps and low rims for incredible playing comfort. The lightweight wood shell Surdos allow for hours of comfortable play when worn over the shoulder with the provided strap. Available in 18"x22", 20"x18" and 22"x22" sizes (diameter x depth), Pearl's popular Surdos continue to be the industry standard. The Timbao is made from lightweight fiberglass, and is capable of the extremely high tension utilized in tradition Brazilian ensembles. The Rocar is equipped with brass and steel platinellas, and can be played as a single shaker, or separated for two-handed sonic options.



**PBTB-140** TIMBAO  
**PBTA-1420** TAN TAN  
**PBS-2018** SURDO 20"  
**PBS-1822** SURDO 18"  
**PBS-2222** SURDO 22"  
*(Shown with optional PBS-30BD)*



**PBS-30BD** LEGS & BD ADAPTER KIT FOR SURDO  
**PBT-70S** TAMBORIM STICK  
**PBSM-20** SURDO Mallet



**PBCX-1204** CAIXA 12"  
**PBCX-1265** CAIXA 12"  
**PBC-80SS** CUICA  
**PBR-10S** REPINIQUE 10" w/ Strap  
**PBR-12S** REPINIQUE 12" w/ Strap



**PBP-510** PANDEIRO 10" (5 sets platinellas & goatskin head) w/ bag  
**PBP-612** PANDEIRO 12" (6 sets platinellas & plastic head) w/ bag  
**PDZ-510** PANDANZA w/ Agogo Bell  
**PBT-60C** TAMBORIM w/ Quick Draw Mount

## CONCERT PERCUSSION

Pearl is proud to offer Concert Percussion instruments that are attractively priced for school ensembles, yet engineered with the professional percussionist in mind. The symphonic tambourine is a perfect example. Its 17 pairs of specially aged, stamped brass jingles provide a dry, yet bright tone that brings added color to any musical situation. Its 10" headed wood frame allows the player to effortlessly perform all tambourine techniques, and the tambourine's plush carrying case is included. The rattler is another vital component to any concert percussionists' equipment, and Pearl's is built with an extended handle for a comfortable grip and ease of playing. Holders for the rattler and castanets are also available.



**PCWTB05** TEMPLE BLOCKS  
**PRT-10** RATTLER  
**PETM-20** ELITE CONCERT TAMBORINE  
**PETM-1017** SYMPHONIC TAMBORINE



Play the Triangle without a beater using the Six-Free Holder.



**PCN-20S** CASTANETS  
**PCN-20H** CASTANETS HOLDER  
**PSS-100** SLAP STICK  
**PCWB-100A** (High)  
**PCWB-200A** (Medium)  
**PCWB-300A** (Low)



**PPS-12T** SIX-FREE TRIANGLE HOLDER w/ 8" Triangle  
**PET-100** 10" TRIANGLE  
**PET-80** 8" TRIANGLE  
**PET-60** 6" TRIANGLE  
**PTC-10** TRIANGLE CLIP  
**PTC-300** TRIO TRIANGLE HOLDER

# HAND PERCUSSION

A WORLD OF HAND PERCUSSION.



PNG-20  
NATURAL GOURD GUIRO



PMG-20  
METAL GUIRO



PFM-20  
BEADED MARACAS

PFM-50  
MARACABASA



PGA-20  
BASKET GANZA 9" x 4"



PGA-32 (Long) PGA-30 (Short)  
HEX GANZAS



PGA-40  
TRIPLE SHAKER



PGA-50SF  
GROOVE SHAKER



PEC-1  
EGG CARTON



PWR-40  
SHAKELETS



PTH-10B (Brass) PTH-10S (Steel)  
HEADLESS WOOD TAMBOURINES



PTM-10GH  
TAMBOURINE W/ BRASS JINGLES



PTM-10SH  
STEEL JINGLE TAMBOURINE  
W/ STAINLESS STEEL JINGLES



PTM-50BHR (Brass)  
PTM-50SHR (Steel, not pictured)  
ULTRA GRIP VOLUME ADJUSTABLE TAMBOURINE



CBS-100  
GATLING CABASA



PTG-20  
TANG-TANG



ASH TONE BLOCKS



PBL-10 CLAVE BLOCK (High) PBL-20 CLAVE BLOCK (Medium) PBL-30 CLAVE BLOCK (Low)



PSC-30  
SPIRIT CHIMES W/ HOLDER & MALLET



PWCH-3620A  
36 ANODIZED ALUMINUM BARS WITH CASE, HOLDER AND STRIKER



PWCH-3220G  
32 GOLD ANODIZED ALUMINUM BARS WITH CASE, HOLDER AND STRIKER

# PERCUSSION STANDS BAGS + HOLDERS

PRO TOOLS FOR EVERY GIG.

## PERCUSSION STANDS & BRACKETS

The PC-3000TW stand holds full size professional congas as securely as most stands double its weight and mass. The PC-300W is scaled down to support our lighter Primero Conga line-up. Both stands set-up in seconds because there are no wingnuts needed to mount your congas. The PC-3000TW includes a carrying bag. The PC-2500 Ultralite Conga stand, is lightweight yet sturdy and stable. Index markings on all adjustable parts make for consistent lightening fast set-ups, and teardown is just as quick and easily portable utilizing the PSC-2000 ergonomic carrying case.



PB-700BHS  
BONGO ATTACHMENT FOR  
PC-200



PC-200  
PRIMERO TWIN CONGA STAND

PC-3000TW  
QUICK RELEASE DOUBLE  
CONGA STAND W/ BAG

PC-2500  
ULTRA LITE CONGA STAND

PC-900  
ALL-FIT  
CONGA STAND

PB-900W  
ALL-FIT TILTING  
BONGO STAND

PB-700  
LIGHTWEIGHT  
BONGO STAND

## TRAP TABLE & RACK

Our popular PTT-1824 Trap Table can be easily converted into a two-level folding rack without drilling or modifications by simply adding the PTR-1824 Add-On Rack. The PTR-1824 installs in seconds using clamps and folds flush with the table for easy pack-up. A unique clamping system allows the included (4) straight and (4) angled 3/8" knurled posts to clamp anywhere onto horizontal or vertical areas of the rack. Also included is a retractable three-legged stabilizer bar for optimum stability. The easy-to-attach PTR-UNV Universal Trap Table Rack mounts on virtually any trap table and features six 3/8" rods and receptors for various percussion mounting possibilities.



PTR-UNV  
UNIVERSAL TRAP TABLE RACK

PTT-1824  
TRAP TABLE (18" x 24")

PTT-1824 + PTR-1824  
TRAP TABLE RACK

PTT-1212  
TRAP TABLE (12" x 12")

(FOR PTT-1824, PTT-1212)

PTR-1824RC3  
TRAP TABLE SINGLE POST ADAPTER

## PERCUSSION CASES

Pearl's padded carrying cases include features like ergonomic carrying straps, rubber protective bottoms, top-mounted carrying handles, tuning wrench pouches, and heavy duty double zippers.



PSC-BB  
BONGO BAG

PSC-125CG  
CONGA BAG  
12.5"

PSC-117CG  
CONGA BAG  
11.75"

PSC-110CG  
CONGA BAG  
10"

PSC-140DJ  
DJEMBE BAG  
14"

PSC-125DJ  
DJEMBE BAG  
12.5"

PSC-1213CJ  
BOX CAJON CASE

PSC-2000  
ULTRA LITE CONGA  
STAND CASE

PSC-1175TC  
TRAVEL CONGA CASE

## HOLDER + ACCESSORIES



PTVB-1212  
PERCUSSION TOY BOX  
(accessories not included)

PPS-37  
ANGLED POST ADAPTER

PPS-40  
LUG MOUNT  
ACCESSORY HOLDER

PGH-20  
UNIVERSAL GUIRO HOLDER

PPS-20  
FOOT PEDAL BRACKET

PCS-10  
COWBELL STACKER

PPS-10 & PPS-11  
STIX-FREE

CA-130

75H

75X

PPS-01

PPS-02

COWBELL  
HOLDERS

# REPLACEMENT PARTS

## ULTRA-SOUND SNARES

Pearl's Ultra-Sound snares feature patented Graduated Tension wires for extended dynamic range from ultra soft to ultra loud. Ultra-thin, low mass end plates assure ultra quick response. The end plates feature three mounting options: tunnels or holes for cord mounting and slots for straps.

U.S. PAT. 7,202,405



SN-1320C	20 strands for 13", C-type, w/straps & cords
SN-1320D	20 strands for 13", D-type, w/straps & cords
SN-1320I	20 strands for 13", I-type, w/straps & cords
SN-1420C	20 strands for 14", C-type, w/straps & cords
SN-1420D	20 strands for 14", D-type, w/straps & cords
SN-1420I	20 strands for 14", I-type, w/straps & cords



SN-1442C	42 strands for 14", C-type, w/straps & cords
SN-1442D	42 strands for 14", D-type, w/straps & cords
SN-1442I	42 strands for 14", I-type, w/straps & cords

## REPLACEMENT SNARES



S-022N	20 Strand for 14" w/Cords
S-022NU	20 Strand for 14" w/Cords, Uncoated
S-022	20 Strand for 14" w/Straps
S-025	20 Strand for 14" long, w/Straps
S-029N	20 Strand for 13" w/Cords
S-030N	24 Strand for 14" w/Cords
S-031N	20 Strand for 12" w/Cords
S-032N	12 Strand for 10" w/Cords
S-033N	12 Strand for 12" w/Cords
S-040	15 Strand for 14" w/Cords, Steel Cable, Thinner Gauge
S-041	15 Strand for 14" w/Cords, Bronze Cable, Thicker Gauge
SPS-18/6	Plastic Strap (6/pkg)
SNC-40/6	Snare Cord (6/pkg)

## OPTI-LOC

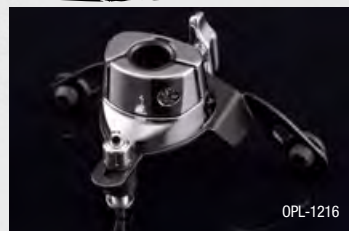

OPL-1216

Opti-Loc suspension tom holders provide exceptional stability while greatly improving resonance and sustain. (For EXX Export)

OPL-0608/C	Opti-Loc for EXX (only) 6"-8" Diameter
OPL-1216/C	Opti-Loc for EXX (only) 12"-16" Diameter

## OPTIMOUNT

Our OptiMount Suspension System attaches to the tom's tension rods and floats on rubber cushions, providing the ultimate in stability while allowing the drum to resonate fully without restriction. With OptiMount, the mounting hardware is completely removed from the drum shell, providing a drastic improvement in resonance and sustain.



OPTA-0708/C	for drums 7"-8" deep, 6"-16" diameter, Light Weight Aluminum	OPT-0708	for drums 7"-8" deep, 6"-16" diameter, UltraGrip Wingnut
OPTA-0910/C	for drums 9"-10" deep, 6"-16" diameter, Light Weight Aluminum	OPT-0910	for drums 9"-10" deep, 6"-16" diameter, UltraGrip Wingnut
OPTA-1112/C	for drums 11"-12" deep, 6"-16" diameter, Light Weight Aluminum	OPT-1112	for drums 11"-12" deep, 6"-16" diameter, UltraGrip Wingnut
OPTA-1314/C	for drums 13"-14" deep, 6"-16" diameter, Light Weight Aluminum	OPT-1314	for drums 13"-14" deep, 6"-16" diameter, UltraGrip Wingnut
OPTA-1516/C	for drums 15"-16" deep, 6"-16" diameter, Light Weight Aluminum	OPT-1516	for drums 15"-16" deep, 6"-16" diameter, UltraGrip Wingnut

## MASTERCAST HOOPS

MasterCast are the finest die cast hoops available and feature the perfect blend of thickness and mass to improve the depth, clarity, and focus of toms and snare drums.



Model #	Diameter	# of Tension
DC-0805	8"	5
DC-1006	10"	6
DC-1206	12"	6
DC-1306	13"	6
DC-1408	14"	8
DC-1408S	14"	8 Snare Side
DC-1410	14"	10
DC-1410S	14"	10 Snare Side
DC-1410SG	14"	10 Snare Side w/Guard
DC-1508	15"	8
DC-1608	16"	8
DC-1808	18"	8

## BASS DRUM HOOP PROTECTORS



HPP-2	Metal Hoop Protector for Wood BD Hoops
NP-01	Hoop Protector for Metal BD Hoops
NP-347/2	Non-Slip Hoop Protector for Wood BD Hoops (pair)

## SUPER HOOP II & FATTONE HOOPS

SuperHoop II hoops are precision formed from heavy-duty 2.3mm steel, triple-flanged and engraved with the SuperHoop II logo. FatTone hoops are low mass 1.6mm hoops with hemmed and welded edges for strength and rigidity.



Super Hoop Model #	FatTone Hoop Model #	Diameter	# of Tension
SH-0604	NA	6"	4
SH-0805	FH-0805	8"	5
SH-1006	FH-1006	10"	6
SH-1006S	NA	10"	6 Snare Side
SH-1206	FH-1206	12"	6
SH-1208	NA	12"	8
SH-1208S	NA	12"	8 Snare Side
SH-1306	FH-1306	13"	6
SH-1308	FH-1308	13"	8
SH-1308S	FH-1308S	13"	8 Snare Side
SH-1408	FH-1408	14"	8
SH-1408S	NA	14"	8
SH-1410	FH-1410	14"	10
SH-1410S	FH-1410S	14"	10 Snare Side
SH-1410SG	NA	14"	10 Snare Side w/Guard
SH-1508	FH-1508	15"	8
SH-1608	FH-1608	16"	8
SH-1808	FH-1808	18"	8

## STEEL HOOPS

RH-0804	8" 4
RH-1006	10" 6
RH-1206	12" 6
RH-1306	13" 6
RH-1408	14" 8
RH-1408S	14" 8 Snare side
RH-1608	16" 8
RH-1808	18" 8

## MASKING COVERS

The GK-90 and BBC-1 cover the holes of BT-3 and BB-3 brackets that have been removed.



BBC-1	for BB-3, w/Gasket, Screws and Nuts
GK-90	for BT-3, inside/outside plates w/Bolts

## SPIN-TIGHT™ TENSION RODS

Specially-designed stainless steel tension rods that lock to maintain tension settings. Starter pack includes 4 Spin-Tight Tension rods with K-180 Drum Key.



K-180	
SPT-5047	W7/32 x 47mm (1)
SPT-4SPK	W7/32 x 47mm (4) w/ K-180 Drum Key
SPT-6PK	W7/32 x 47mm (6)

## STAINLESS STEEL TENSION RODS

Pearl's Stainless Steel Tension Rods are machined, not forged, from a single piece of stainless steel to the most exacting tolerances in the industry. They feature super-smooth, precise tensioning, with absolutely no play. Each non-plated stainless steel tension rod is matched with a precision-machined brass swivel nut for ultra-precise performance.

SST-5028/6	W7/32 x 28mm (6)
SST-5035/6	W7/32 x 35mm (6)
SST-5038/6	W7/32 x 38mm (6)
SST-5042/6	W7/32 x 42mm (6)
SST-5047/6	W7/32 x 47mm (6)
SST-5052/6	W7/32 x 52mm (6)

## TENSION ROD WASHERS

NLW-12B/12	Nylon Washers (12) Black	MTW-12/12	Metal Washers (12)
------------	--------------------------	-----------	--------------------

## TENSION ROD LOCKNUTS

TNK-10N/10	Tension Rod Lock Nuts (10/pkg)
TL-20/10	Tension Keeper (10/pkg)

## CAMS + BEATER WEIGHT

EPAP-1	Package: Beater Weight, Purple Cam, Yellow Cam
CAM-PL	Eliminator Purple Cam, Aggressive Action
CAM-YL	Eliminator Yellow Cam, Inverse Action
CAM-BK	Eliminator Black Cam, Linear Action
CAM-WT	Eliminator White Cam, Oversized Linear Action
CAM-BL	Eliminator Blue Cam, Progressive Action
CAM-RD	Eliminator Red Cam, Radical Action
BW-100	Beater Weight, 3 Weights in One (U.S. Patent #7122730)

## CHAINS + BELTS

CCA-5	Chain Assy Complete for Eliminator Pedals
CCA-10	Chain Assy Complete for 1000 Series Power Shifter/PowerPro
CCA-1	Chain Assy Complete for 120 Series
BCA-1	Belt Assy Complete for Eliminator Pedals
BCA-10	Belt Assy Complete for 1000 Series

## HI-HAT CLUTCHES

DCL-300P	Drop Clutch, Rubber Washers, Lock Nut
SGC-300P	Super Grip Clutch, Rubber Washers, Lock Nut
CL-300P	Clutch, Triple-Lock, Rubber Washers, Lock Nut
CL-300	Clutch, Triple-Lock, Felt Washers, Lock Nut
CL-68N	Clutch, Standard, Felt Washers

Lock Nut	U.S. Patent #7326843
----------	----------------------

## DRUM KEYS

KGT-100	Gyro Tune Key w/Quick Release
K-030	Hi-Tension Tuning Key
K-050	Tuning Key
K-180	Spin-Tight Key

## JUNGLE GIG CONVERSION

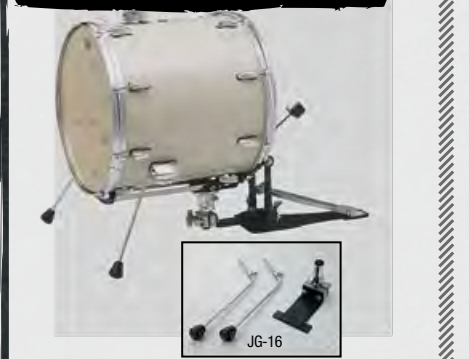

JG-16 • Pearl's Jungle Gig allows the conversion of a 16" Floor Tom to a Bass drum.

## PRACTICE PADS

### BASS DRUM PEDAL TRAINING PADS

BD-10 The BD-10 bass pad is perfect for practicing at home or on the road. The wide pad accommodates double pedals and is specially formulated for extremely low noise and a realistic feel. The universal-fit "hoop" accepts all brands of pedals and adjusts to compensate for different floor surfaces. The BD-10 folds for compact transport.



## MUFFLER

External clamp-on muffler for snare drums and toms. By adjusting the pressure and position of the felt pad, excessive overtones can be precisely controlled or eliminated.



OM-1	Clamp-on Muffler, Snare Drum & Toms
------	-------------------------------------

## DRUM HEADS

MUFFLE HEADS			
Size	Model #	Size	Model #
8"	MFH-08	14"	MFH-14
10"	MFH-10	16"	MFH-16
12"	MFH-12	20"	MFH-20B
13"	MFH-13	22"	MFH-22B



AREJAY HALE  
HALESTORM

JEREMY SPENCER  
FIVE FINGER DEATH PUNCH

CASEY GRILLO  
KAMELOT

GIANCARLO DE TRIZIO  
THE BOOK OF MORMON TOUR

BEN JOHNSON  
BUFFY CORD

ROBBY AMEN  
HINDER

KENNEDY DENABO  
BENEFIT JUST DANCE

DENNIS CHAMBERS  
SANTANA

QUINTON ROBINSON  
INDEPENDENT

MICHAEL BUTLER  
AKON

QUINTON JOSEPH  
MONEY BLOOD & THE GEMS

TIM HORTON  
MONEY BLOOD & THE GEMS

DAMI LOBLE  
HELMET

MIKO SIREN  
APOCALIPTICA

CRIZ  
LACUNA COIL

MELVIN BALDWIN  
JUSTI BIRER

GENE HOGAN  
TESHAWART / OTHROK

CODY HANSON  
HINDER

JASON BITTNER  
SHADOWS FALL

MARVIN SMITTY SMITH  
INDEPENDENT

RANDY BLACK  
PRIMAL FEAR

ROBBY AMEN  
HINDER

KRIS MYERS  
UMPHREY'S MCGEE

CHAD SEXTON  
311

OMAR HAKIM  
INDEPENDENT

MORGAN ROSE  
SEVENDUST

ELMO LOVANO  
MY PET

MATT ABTS  
GOVT MULE

GARY HUSBAND  
INDEPENDENT

GENE HOGAN  
TESHAWART / OTHROK

CODY DICKINSON  
NORTH MISSISSIPPI ALLSTARS

MATTY AMENDOLA  
INDEPENDENT

TRACY BROUSSARD  
BLAKES SHELTON

ADRIAN ERLANDSSON  
PARADISE LOST / AT THE GATES

JASON BITTNER  
SHADOWS FALL

JUSTIN BENNER  
HAWK NELSON

RAY LUZIER  
KORN

SAM LOEFFLER  
CHELLE

TONY PALERMO  
PAPA ROACH

JOHN LONGSTRETH  
ORIGIN

WILL KENNEDY  
YELLOWJACKETS

STANLEY RANDOLPH  
STEVIE WONDER

JUSSIG  
THE 69'ERS

TOMMY LEE  
MOTEL KATIE

CODY DICKINSON  
NORTH MISSISSIPPI ALLSTARS

MATTY AMENDOLA  
INDEPENDENT

GRANT COLLINS  
INDEPENDENT

TRE STAFFORD  
ADELITAS WAY

TRACY BROUSSARD  
BLAKES SHELTON

JOEY JORDISON  
SCAR THE MARTYR

ADRIAN ERLANDSSON  
PARADISE LOST / AT THE GATES

CHAD BRACKETT  
LIVE

RAY LUZIER  
KORN

SAM LOEFFLER  
CHELLE

JASON HARTLESS  
PISTOL DAY PARADE

TONY PALERMO  
PAPA ROACH

JOHN LONGSTRETH  
ORIGIN

WILL KENNEDY  
YELLOWJACKETS

TERENCE HIGGINS  
WARREN HAYNES

JOE SPURGEON  
THE HORRORS

BRIAN FRASIER MOORE  
JUSTIN TIMBERLAKE

GRANT COLLINS  
INDEPENDENT

JEREMY STRATTON  
HED P.E.

ASH PEARSON  
3 INCHES OF BLOOD

TRE STAFFORD  
ADELITAS WAY

WUV  
P.O.D.

JOEY JORDISON  
SCAR THE MARTYR

CHAD BRACKETT  
LIVE

RAY LUZIER  
KORN

SAM LOEFFLER  
CHELLE

JASON HARTLESS  
PISTOL DAY PARADE

TONY PALERMO  
PAPA ROACH

JOHN LONGSTRETH  
ORIGIN

WILL KENNEDY  
YELLOWJACKETS

TERENCE HIGGINS  
WARREN HAYNES

JOE SPURGEON  
THE HORRORS

BRIAN FRASIER MOORE  
JUSTIN TIMBERLAKE

GRANT COLLINS  
INDEPENDENT

JEREMY STRATTON  
HED P.E.

ASH PEARSON  
3 INCHES OF BLOOD

TRE STAFFORD  
ADELITAS WAY

WUV  
P.O.D.

JOEY JORDISON  
SCAR THE MARTYR

CHAD BRACKETT  
LIVE

RAY LUZIER  
KORN

SAM LOEFFLER  
CHELLE

JASON HARTLESS  
PISTOL DAY PARADE

TONY PALERMO  
PAPA ROACH

JOHN LONGSTRETH  
ORIGIN

WILL KENNEDY  
YELLOWJACKETS

TERENCE HIGGINS  
WARREN HAYNES

JOE SPURGEON  
THE HORRORS

BRIAN FRASIER MOORE  
JUSTIN TIMBERLAKE

GRANT COLLINS  
INDEPENDENT

JEREMY STRATTON  
HED P.E.

ASH PEARSON  
3 INCHES OF BLOOD

TRE STAFFORD  
ADELITAS WAY

MOOSE  
BULLET FOR MY VALENTINE

WUV  
P.O.D.

JASJA  
CHILDREN OF BLOOD

CHRIS VEST  
FRAMING HANLEY

RODNEY HOWARD  
AVRIL LAVIGNE

RICKY LANSON  
INDEPENDENT

JESSE CARABALLO  
MARC ANTHONY

WILL HUNT  
EMERGENCY

TODD SUCHERMAN  
STYX

DANIEL ERLANDSSON  
ARCH ENEMY

RYAN MORAN  
SLIGHTLY STOOPID

TYLER STEWART  
BARENAKED LADIES

BRIAN VODINH  
10 YEARS

JOE TOMINO  
MATSIYAHU / DUB TRIO

WES LITTLE  
JOE NICHOLS

DAVE SIMMONS  
KC & THE SUNSHINE BAND

GEORGE KOLLAS  
NINE

MOOSE  
BULLET FOR MY VALENTINE

JASJA  
CHILDREN OF BLOOD

CHRIS VEST  
FRAMING HANLEY

RODNEY HOWARD  
AVRIL LAVIGNE

RICKY LANSON  
INDEPENDENT

JESSE CARABALLO  
MARC ANTHONY

WILL HUNT  
EMERGENCY

TODD SUCHERMAN  
STYX

DANIEL ERLANDSSON  
ARCH ENEMY

RYAN MORAN  
SLIGHTLY STOOPID

TYLER STEWART  
BARENAKED LADIES

BRIAN VODINH  
10 YEARS

JOE TOMINO  
MATSIYAHU / DUB TRIO

WES LITTLE  
JOE NICHOLS

DAVE SIMMONS  
KC & THE SUNSHINE BAND

MIKE MANGINI  
DREAM THEATER

GEORGE KOLLAS  
NINE

JASJA  
CHILDREN OF BLOOD

CHRIS VEST  
FRAMING HANLEY

RODNEY HOWARD  
AVRIL LAVIGNE

RICKY LANSON  
INDEPENDENT

JESSE CARABALLO  
MARC ANTHONY

WILL HUNT  
EMERGENCY

TODD SUCHERMAN  
STYX

DANIEL ERLANDSSON  
ARCH ENEMY

RYAN MORAN  
SLIGHTLY STOOPID

TYLER STEWART  
BARENAKED LADIES

BRIAN VODINH  
10 YEARS

JOE TOMINO  
MATSIYAHU / DUB TRIO

WES LITTLE  
JOE NICHOLS

DAVE SIMMONS  
KC & THE SUNSHINE BAND

**MASTERS MAPLE + MASTERS BIRCH**

**MCX924XP/C**  
**BCX924XP/C**  
 22"x18"  
 12"x9" 13"x10"  
 16"x16"

**MCX924XSP/C**  
**BCX924XSP/C**  
 22"x18"  
 10"x8" 12"x9"  
 16"x16"

**MCX904XP/C**  
**BCX904XP/C**  
 20"x18"  
 10"x8" 12"x9"  
 14"x14"

**#103 PIANO BLACK**   **#388 SHAMROCK GREEN**   **#800 QUILTED BUBINGA SUNBURST**   **#807 NATURAL BIRDSEYE MAPLE**   **#810 ASH FADE TAMO**

**#357 GOLDEN BRONZE GLITTER**   **#358 SILVER GLITTER**   **#818 LAVA BUBINGA**

**MASTERS MAPLE** (above)  
**MASTERS BIRCH** (left)

**SESSION STUDIO CLASSIC**

**SSC924XUP/C**  
 22"x16"  
 10"x7" 12"x8"  
 16"x14"

**SSC944XUP/C**  
 24"x15"  
 12"x8" 13"x9"  
 16"x14"

**SSC904XUP/C**  
 20"x16"  
 10"x7" 12"x8"  
 14"x14"

**#103 PIANO BLACK**   **#106 ANTIQUE IVORY**   **#110 SEQUOIA RED**   **#113 SHEER BLUE**   **#361 VINTAGE COPPER SPARKLE**   **#389 MATTE LIQUID AMBER**

**VISION VBL**

**VBL925 / VBL925P**  
 22"x18"  
 12"x9" 13"x10"  
 14"x5.5" 16"x16"

**VBL925S / VBL925SP**  
 22"x18"  
 10"x8" 12"x9"  
 14"x5.5" 16"x16"

**VBL905 / VBL905P**  
 20"x18"  
 10"x8" 12"x9"  
 14"x5.5" 14"x14"

**#230 CLEAR BIRCH**   **#232 RUBY FADE**   **#239 GRAPHITE**   **#243 PRUSSIAN BLUE**   **#244 NATURAL BLACK BURST**

**EXPORT**

**EXX725/C**  
**EXX725/PC**  
 22"x18"  
 12"x8" 13"x9"  
 14"x5.5" 16"x16"

**EXX725S/C**  
**EXX725S/PC**  
 22"x18"  
 10"x7" 12"x8"  
 14"x5.5" 16"x16"

**EXX705/C**  
**EXX705/PC**  
 20"x18"  
 10"x7" 12"x8"  
 14"x5.5" 14"x14"

**#21 SMOKEY CHROME**   **#31 JET BLACK**   **#33 PURE WHITE**   **#91 RED WINE**   **#702 ELECTRIC BLUE SPARKLE**

**REFERENCE + REFERENCE PURE STOCK COLORS**

**RF924XP/C**  
**RFP924XP/C**  
 22"x18"  
 12"x9" 13"x10"  
 16"x16"

**RF924XSP/C**  
**RFP924XSP/C**  
 22"x18"  
 10"x8" 12"x9"  
 16"x16"

**RF904XP/C**  
**RFP904XP/C**  
 20"x18"  
 10"x8" 12"x9"  
 14"x14"

**REFERENCE**   **REFERENCE PURE**

**#102 NATURAL MAPLE**   **#103 PIANO BLACK**   **#376 ULTRA BLUE FADE**   **#102 NATURAL MAPLE**   **#103 PIANO BLACK**   **#377 SCARLET SPARKLE BURST**

**REFERENCE + REFERENCE PURE SPECIAL ORDER COLORS**

**#100 WINE RED**   **#109 ARCTIC WHITE**   **#126 EMERALD MIST**   **#128 VINTAGE SUNBURST**   **#142 ROOTBEER FADE**   **#143 TWILIGHT FADE**

**#148 EMERALD FADE**   **#151 PLATINUM MIST**   **#152 ANTIQUE GOLD**   **#153 SUNRISE FADE**   **#154 MIDNIGHT FADE**   **#155 SCARLET FADE**

**#197 RHYTHM BLUE**   **#302 INCA GOLD BURST**   **#330 IVORY PEARL**   **#331 BLACK PEARL**   **#332 RED PEARL**   **#333 PURPLE METALLIC**

**#334 RED METALLIC**   **#335 BLACK CHERRY**   **#368 BLACK SILVER BURST**   **#393 PURPLE CRAZE II**   **#342 VINTAGE TOBACCO BURST (Reference Pure Only)**

**PEARL CORPORATION**  
 Corporate Headquarters  
 549 Metroplex Dr.  
 P.O. Box 111240  
 Nashville, Tennessee 37211-3140  
 (615) 833-4477 • FAX (615) 833-6242



WWW.PEARLDRUM.COM

PGC2014