

MASTERS SERIES

Masters Series Lacquer Finish - Available Colors

		MMX	MPX	MPX	BPX
	No.100 Wine Red				
	No.102 Natural Maple				
	No.103 Piano Black				
	No.112 Natural Birch				
	No.122 Black Mist				
	No.128 Vintage Sunburst				
	No.141 Red Mahogany				
	No.148 Emerald Fade				
	No.151 Platinum Mist				
	No.152 Antique Gold				
	No.153 Sunrise Fade				
	No.154 Midnight Fade				
	No.156 Purple Storm				
	No.160 Silver Sparkle				
	No.165 Diamond Burst				
	No.166 Black Sparkle				
	No.168 Ocean Sparkle				

Masters Series Covered Finish - Available Colors

		MSX
	No.400 White Marine Pearl	
	No.401 Royal Gold	
	No.402 Abalone	
	No.403 Red Onyx	
	No.404 Amethyst	

Pearl[®]
The best reason to play drums.

PEARL DRUMS



www.pearldrum.com

SESSION / EXPORT / FORUM / RHYTHM TRAVELER

Lacquer Finish - Available Colors

		SMX	SBX	ELX
	No.281 Carbon Mist			
	No.282 Storm Cloud			
	No.290 Vintage Fade			
	No.291 Cranberry Fade			
	No.292 Marine Blue Fade			
	No.296 Green Burst			
	No.297 Green Fade			
	No.298 Black Burst			
	No.280 Vintage Wine			
	No.283 Solid Black			
	No.284 Tobacco Burst			
	No.289 Blue Burst			
	No.271 Ebony Mist			
	No.273 Blue Mist			
	No.274 Amber Mist			
	No.294 Amber Fade			
	No.295 Ruby Fade			
	No.299 Cobalt Fade			

Covered Finish - Available Colors

		EXR	EX	FX	RT
	No.430 Prizm Blue				
	No.431 Strata Black				
	No.432 Prizm Purple				
	No.433 Strata White				
	No.435 Strata Blue				
	No.436 Strata Red				
	No.21 Smokey Chrome				
	No.31 Jet Black				
	No.33 Pure White				
	No.44 Carbon Black				
	No.45 Carbon Red				
	No.49 Polished Chrome				
	No.78 Teal Metallic				
	No.91 Red Wine				
	No.95 Deep Blue				
	No.98 Charcoal Metallic				

Pearl[®]
The best reason to play drums.

For more information on these or any Pearl product, visit your local authorized Pearl Dealer. You can also visit us on the World Wide Web Site www.pearldrum.com. Colors shown in this catalogue are for representation only and may not be exactly the same as the original colors due to the printing processes involved. Products and specifications are subject to change without notice. Printed 07/2005 in JAPAN ITEM #PGC507

PEARL DRUMS and PERCUSSION
GENERAL CATALOG
2005 / 2006

PEARL DRUMS

					 Dennis Chambers Independent U.S.A.	 Omar Hakim Independent U.S.A.	 Steve Ferrone Tom Petty U.S.A.	 Will Kennedy Independent U.S.A.	 Horacio Hernandez Independent U.S.A.	 Robby Ameen Independent U.S.A.	 Billy Hart Independent U.S.A.	 Mike Mangini Independent U.S.A.	 Shane Gaalaas Cosmosquad, Diesel Machine U.S.A.	 Rickey Lawson Independent U.S.A.	 Virgil Donati Planet-X, Ring of Fire, Soul Sirkus U.S.A.
			 Chad Smith Red Hot Chili Peppers U.S.A.	 Morgan Rose Sevendust U.S.A.	 Vinnie Paul Damageplan U.S.A.	 Eric Singer KISS U.S.A.	 Tico Torres Bon Jovi U.S.A.	 Scott Rockenfield Queensrÿche U.S.A.	 Jonathan Mover Independent U.S.A.	 Jimmy DeGrasso Independent U.S.A.	 Michael Cartellone Lynyrd Skynyrd U.S.A.	 Chad Gracey Live U.S.A.	 Brian Young Fountains of Wayne U.S.A.	 Donna C The Donnas U.S.A.	
 Joey Jordison Slipknot U.S.A.	 Shawn Drover Megadeth U.S.A.	 Mike Wengren Disturbed U.S.A.	 Wuv P.O.D. U.S.A.	 Daniel Adair 3 Doors Down U.S.A.	 David Buckner Papa Roach U.S.A.	 Matt McDonough Mudvayne U.S.A.	 Ben Graves Murderdolls U.S.A.	 Sam Loeffler Chevelle U.S.A.	 Dave McClain Machine Head U.S.A.	 Craig Nunenmacher Black Label Society U.S.A.	 Bobby Jarzombek Iced Earth U.S.A.	 Criz Lacuna Coil U.S.A.	 Flo Mounier Cryptopsy Canada	 Mitch Dorge Independent Canada	 Paul Delong Independent Canada
 Ian Paice Deep Purple UK	 Darrin Mooney Primal Scream, Gary Moore UK	 Adrian Erlandsson Cradle of Filth UK	 Danny Goffey Supergass UK	 Andy Treacey Faithless UK	 Velroy Bailey Westlife UK	 Liam Bradley Ronan Keating UK	 Matt Tong Bloc Party UK	 Ian Matthews Kasabian UK	 Martin Stoeck Pur Germany	 Pete York Independent Germany	 Tom Hapke Independent Germany	 Juergen Stiehle Die Happy Germany	 Vom Ritchie Die Toten Hosen Germany	 Rick Gratton Independent Canada	 Kim Urhahn Lilix Canada
 Phil Jordan The Music UK	 Adams Perry A UK	 Andy Williams Doves UK	 Mike Chiplin Lostprophets UK	 Ryan Richards Funeral for a Friend UK	 Mark Brzezicki Procol Harum UK	 Pete Lewinson Simply Red UK	 Gareth Brown Blue UK	 Christophe Deschamps Independent France	 Eric Sarthou AqME France	 Laurent Faucheu Independent France	 Raphael Mercier Mass Hysteria France	 David Salkin Independent France	 Bandini Independent Italy	 GATTO Independent Italy	 Marangolo Independent Italy
 Koen Liekens K'Choice Belgium	 Jonas Ekdahl EVERGREY Sweden	 Christer Sjöström Independent Sweden	 Daniel Erlandsson Arch Enemy Sweden	 Morgan Ågren Independent Sweden	 Lacu Hanoi Rocks Finland	 Jussi 69 The 69 Eyes Finland	 Jaska Children of Bodom Finland	 Aki Hakala The Rasmus Finland	 JAY NEGATIVE Finland	 Jukka Uotila Independent Finland	 Cesar Zuiderwijk Independent Holland	 Ernst van Ee Independent Holland	 Lucas van Merwijk Independent Holland	 Cyril Directie Candy Dulfer Holland	
 Quim Sole Independent Spain	 Juan De La Oliva Independent Spain	 David Barcos Independent Spain	 Igor Cavalera SEPULTURA Brazil	 Haroldo Ferretti Skank Brazil	 Maguinho Independent Brazil	 Ricardo Confessori Shaman Brazil	 Rudy Sanchez Independent Mexico	 Pablo Bernal Independent Columbia	 Rune Arnesen Nils Petter Moivaer Norway	 Anders Engen Bjorn Eidsvåg Norway					
 Grant Collins Independent Australia	 Karl Lewis Bachelor Girl Band, Independent Australia	 Jon Farris INXS Australia	 Andy Strachan The Living End Australia	 Su-Ho Kang Independent Korea	 Zhang Jiong life and death Again China	 Munetaka Higuchi Loudness Japan	 Shuichi "Ponta" Murakami Independent Japan	 Hiro Tsunoda Independent Japan							

Gorden Campbell • Kenwood Dennard • Terence Higgins (Dirty Dozen Brass Band) • Stix Hooper (The Crusaders) • Matt Wilson • Tommy Campbell • Casey Schueerell • Ricky Sebastian • Kim Plainfield
 Clarence Penn • Lionel Cordew • Barry Kerch (Shinedown) • Rene Martinez (Intocable) • Todd Sucherman (Styx) • Johnny Kelly (Type O Negative) • Jerry Gaskill (King's X) • Pete Sandoval (Morbid Angel)
 Steve Gillis (Filter) • John Humphrey (Seether) • Jeremy Hummel (Breaking Benjamin) • Crispy (Motograter) • Brian Prout (Diamond Rio) • Gene Jackson • Jerry Brown • Robin Guy • Nick Menza
 Billy Osbourne • Carlos Hercules • Ben Byrne (Starsailor) • Colin Newton (Idlewild) • Graham Hopkins (Gemma Hayes) • Jason Bowld (Pitchshifter) • Mitch Glover (Kosheen) • Neil Payne (Texas)
 Clive Jenner (Groove Armada) • Sebastiaan De Krom (Jamie Cullum) • Smiley (Archive) • Tom/Alex White (The Electric Soft Parade) • John Jenkins (The Streets) • Gordan Morison (Raging Speedhorn)
 Dan Foord (Sikh) • Dave Clarke (Hot House Flowers) • Spike T. Smith (Morrissy) • Stidi (The Wildhearts) • Jimmy Brown (UB40) • Harry James (Thunder, Magnum)



Your Leader in Innovation and Quality, From Studio to Stage.

For over 50 years, Pearl has consistently raised the bar for quality, innovation and craftsmanship. From our entry level Forum Series to our completely custom made Masterworks, the Pearl name is synonymous with value and performance. 2004 brings a virtual cornucopia of new and improved products. The introduction of our Advanced Hardware Systems will change the way that you look at drum hardware forever. Our Export Series has blurred the line between an entry level kit and high end performance. Our midline Session Series drums now offer a choice of 100% Maple or 100% Birch shells in professional quality finishes. Masters offers a choice of 5 series featuring unique shell configurations and a choice of 4 hardware finishes. Our flagship model Masterworks sports all new lugs and is still the only truly custom drums. You dream it and we'll build it. It's as simple as that.



Drum Hardware

The Perfect Compliment to a Great Set of Drums

The same tireless pursuit of perfection that goes into our legendary drums is found in our hardware. Hardware designed to maximize the sound of your drums. Pearl Hardware has set the standard for strength, durability and innovation. It's the choice of working professionals who depend on their equipment. Sure-footed on the stage or in the studio, when the show must go on, count on Pearl hardware.

Advanced Hardware Systems

Advancing the Way that you Play

Not just hardware, but an engineering marvel. Our Advanced Hardware Systems is the ultimate foundation for the studio musician. Each component incorporates features like our over-sized rubber feet to provide grip and absorb vibrations, no rattle tubes and our UltraGrip wingnuts that provide rock solid positioning night after night.

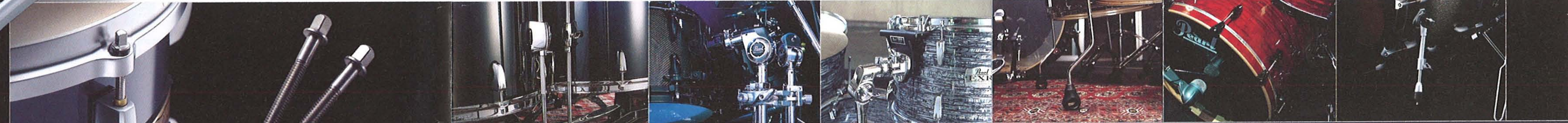
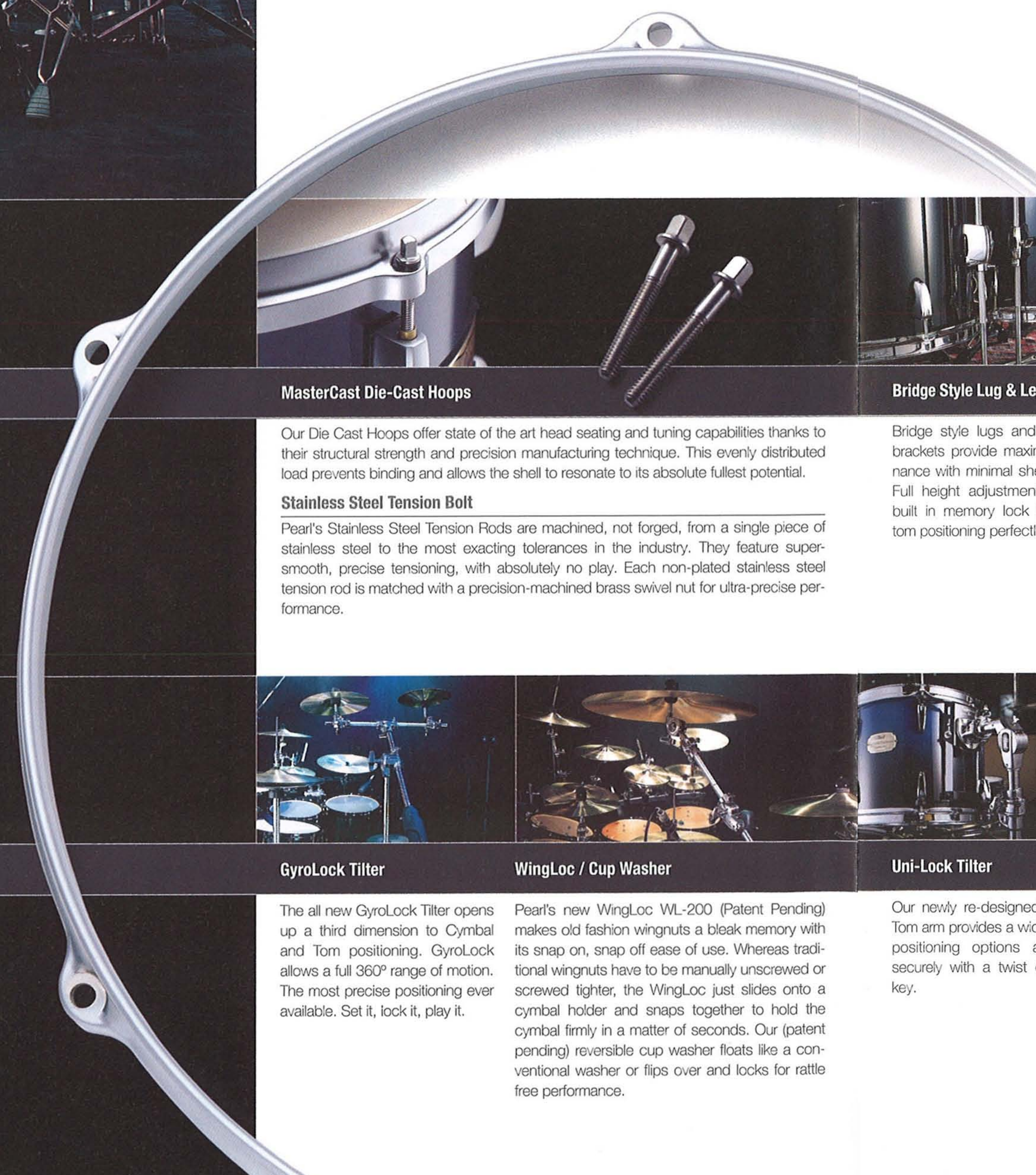

MasterCast Die-Cast Hoops

Our Die Cast Hoops offer state of the art head seating and tuning capabilities thanks to their structural strength and precision manufacturing technique. This evenly distributed load prevents binding and allows the shell to resonate to its absolute fullest potential.

Stainless Steel Tension Bolt

Pearl's Stainless Steel Tension Rods are machined, not forged, from a single piece of stainless steel to the most exacting tolerances in the industry. They feature super-smooth, precise tensioning, with absolutely no play. Each non-plated stainless steel tension rod is matched with a precision-machined brass swivel nut for ultra-precise performance.

Bridge Style Lug & Leg Bracket

Bridge style lugs and floor tom brackets provide maximum resonance with minimal shell contact. Full height adjustment with our built in memory lock keep floor tom positioning perfectly set.

OptiMount Suspension System

The OptiMount Suspension System provides Tom mounting with no shell contact for ultimate resonance. By attaching to the tension bolts via insulated rubber bushings the shell is allowed to float which in turn allows it to sing to its fullest capabilities.

Integrated Suspension System

Our I.S.S. mounting system mounts securely to the tom rim the shell is unencumbered by hardware and promotes maximum resonance and sustain.

Air Suspension Rubber Tip

Air Suspension feet allow your floor tom to rest on a cushion of air. These large rubber feet prevents premature sound decay from floor contact. Floor toms never had it so good.

Bass Drum Claw

Our Bass Drum Claws incorporate rubber hoop isolators that prevent scratching of your lacquer hoops and provide even clamping force for consistent tuning. Our recessed key bolt provides easy access with a clean, non protruding design.

Bass Drum Spur

Our telescoping spurs give maximum traction control on any floor surface. The standard high grip rubber tip can be retracted to allow a recessed spike to be exposed for maximum "bite" on surfaces such as carpet.

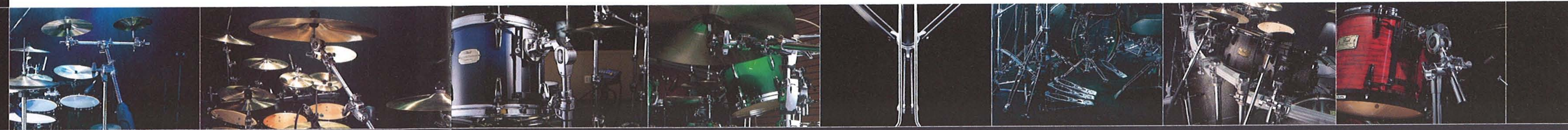

GyroLock Tilter

The all new GyroLock Tilter opens up a third dimension to Cymbal and Tom positioning. GyroLock allows a full 360° range of motion. The most precise positioning ever available. Set it, lock it, play it.

WingLoc / Cup Washer

Pearl's new WingLoc WL-200 (Patent Pending) makes old fashion wingnuts a bleak memory with its snap on, snap off ease of use. Whereas traditional wingnuts have to be manually unscrewed or screwed tighter, the WingLoc just slides onto a cymbal holder and snaps together to hold the cymbal firmly in a matter of seconds. Our (patent pending) reversible cup washer floats like a conventional washer or flips over and locks for rattle free performance.

Uni-Lock Tilter

Our newly re-designed Uni-Lock Tom arm provides a wide range of positioning options and locks securely with a twist of a drum key.

Die-Cast Joint

Our all new pipe joint incorporated into our Advanced Hardware Systems is absolutely the strongest clamp on the market today. It features internal nylon bushings that prevent metal to metal contact within the tube for true silent operation. The UltraGrip wingnut provides superior leverage for tightening and loosening of the clamp.

SureStrut

The double strut design incorporated into our Advanced Hardware Systems promotes optimal rigidity with true silent operation. It prevents lateral wobble and potential metal squeaks.

Rubber Tip

These over-sized rubber feet provide double duty by providing superior traction and advanced vibration absorption.

Convertible Spike / Rubber Tip

Our S-2000 Snare Stand and H-2000 Hi-hat provide an ingenious hidden spiked tip that is accessible with just a push of a button. Push a second button and it instantly disappears. (Pat. Pending)

Curved Rack / Pipe Clamp

The ICON Rack System has set the standard for drum rack systems. Often imitated but never duplicated. The new DR501C features a subtle curve that allows your drums to flow around you for a very natural feel. Our new PCX-100 and PCX-200 clamps offer precise die-cast construction for sure fit and adjustable jaws that accommodate a wide range of tubing sizes.

Universal Clamp

This is a true multi-tasking tool. The Universal clamp has so many potential uses. With a 7/8" diameter tube and built in swivel, it works perfectly as a secondary snare mount, tom mount or any other effect that needs superior positioning. The quick release clamp makes it a snap to use, anywhere.

A Brief History of Materials

Throughout history drum shell composition has ridden the waves of music trends, recording advances and popular perception. Obvious trends in live performances and in the recording industry reflect "The Sound" of that particular era. In the 60's it was Maple and Mahogany for the new phenom called "Rock Bands". Into the 70's Maple gained popularity with heavier forms of Rock emerging and venues becoming larger. In the eighties with the onslaught of Metal, everything got bigger and louder. Maple shells lined with interior plies of Fiberglass were even used with thunderous approval. By the early 90's Maple became the perceived standard with Birch now gaining ground with players and sound engineers. Pearl's history in shell construction goes beyond traditional composition. Years of experimenting with different woods and combinations of materials such as Fiberglass, Acrylics, Aluminum and Carbon Fiber have led us to a more thorough understanding of how certain materials and select blends of unique materials influence the overall response of the shell. Some of the most memorable performances in history have taken place using some of these futuristic hybrids. Trends in shells will always ebb and flow and the choice of wood generally follows your taste in music or particular playing style. No matter the makeup of the drum it all comes down to how effectively the shell can redirect the energy that is transmitted to the head via the sticks.

The Pursuit of the Perfect Shell

The nucleus of Pearl's legendary performance is our proprietary shell manufacturing process, the Heat Compression Shell Molding System. HC/sms assures a perfectly formed shell every time. We begin with the finest select

aged wood plies with tapered scarf joints cut on each end. These scarf joints allow the seams to overlap and prevent any voids or dead spots that can occur with common butt seams. Each ply is then coated with a proprietary adhesive formula that when heated, hardens to the same consistency as the wood it binds. The plies are then hand formed and inserted into a hydraulic compression die mold, which compresses the plies inward and outward at a force equal to 70Kgf per square centimeter. All of this takes place at an extreme temperature until the glue boils and permeates every pore of the wood. This ensures a shell of consistent density through and through. These precision made shells are then thoroughly inspected for perfectly even edge contact. Next, our bearing edge is applied. This critical step in the shell making process is another key component in the quality of our shells. By cutting the 45° angled edge from the inner shell and then cutting the opposing 45° bearing edge closer to the outside of the shell we are able to utilize optimal shell diameter. This bearing edge provides the perfect platform for your drum head through this highly focused contact point offering tuning

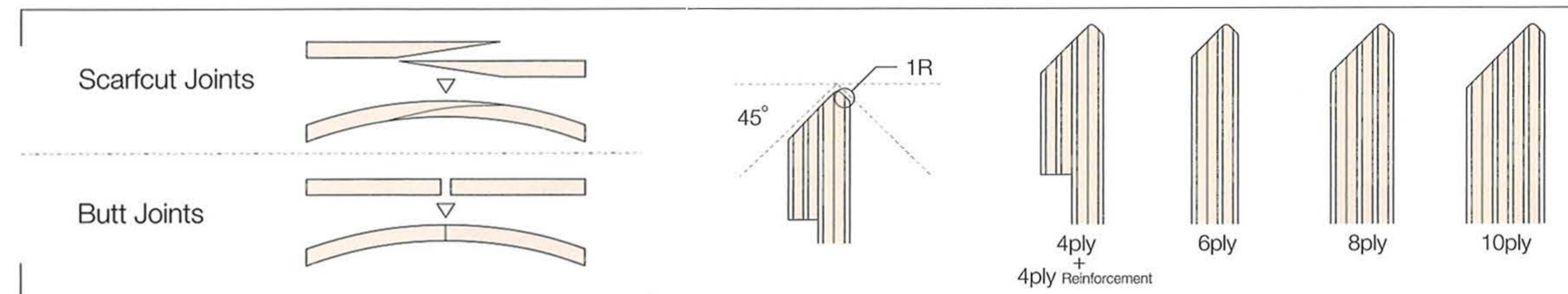

The Science of Masterworks

Masterworks represents all that is possible in shell manufacturing, by offering a selection of shell materials, ply thicknesses and any combination of each, the ability to perpetuate and hone the sound that you desire is available to anyone through the science of Masterworks.

Through Thick and Thin

Research has shown that as the shell thickens, through the addition of overall plies, less energy is lost through shell resonance and thereby project higher Sound Pressure Levels. Essentially, project more energy within the confines of a tighter focus. In contrast thinner shells offer easy energy transfer that optimizes resonance projecting from the shells for that close up, "player's experience." Perfect for recording where microphone placement can capitalize on the warmth and natural tone of the instrument.

Blending In

Only Pearl can offer the selective drummer of today the opportunity to customize every aspect of their drums to reflect their individual taste. The ability to select the shell

thickness, from 4 plies to 10 plies. Select the composition of the individual plies from three unique woods, each prized for their individual sonic properties. 100% African Mahogany provides a strong bottom end with deep, resounding sustain. 100% Maple combines a strong punch with balanced midtones and highs. Ideal for overall applications. 100% Birch maintains a solid low end with smooth mids and greater high-end presence. Even the option of artisan finished outer plies of opulent African Bubinga or exotic Tamo are available.

The Big Finish

As with every other aspect of Masterworks, the finish is up to you. A time intensive 31 step process that ends with the most spectacular custom finish available in the industry. With over 50 years of drum manufacturing research and development, Pearl offers the discriminating player the ultimate feature in a set of drums. Choice.

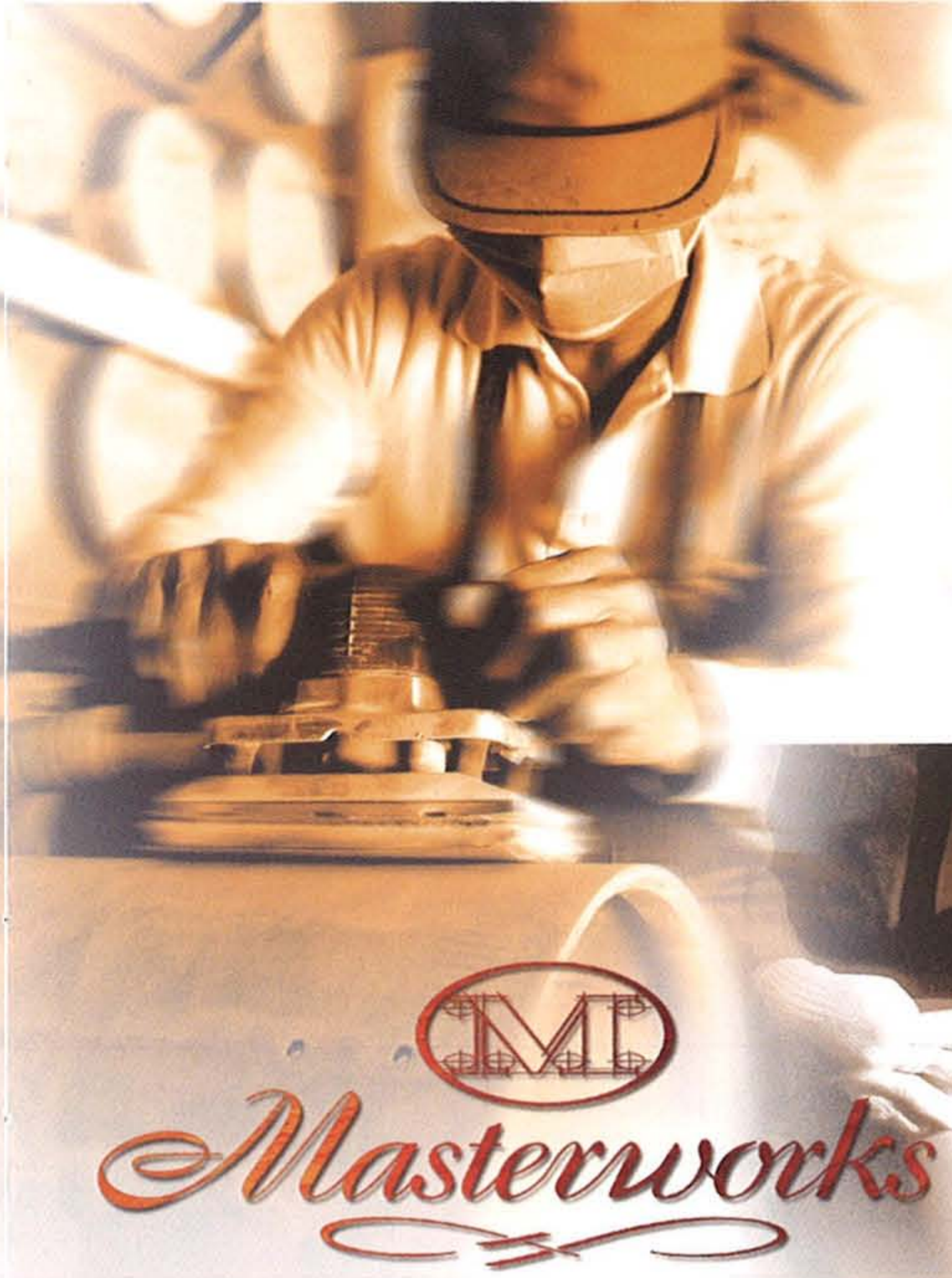

Our HC/sms assures manufacturing excellence, every time.

The making of the perfect shell is a painstaking process. First, the finest raw materials are hand selected, adhered together with a proprietary glue, heated to extreme heat and pressure in our exclusive molds, shell ends are squared and trued and our bearing edge is cut. Finally our thirty one step finish is applied. Voila! The perfect shell.

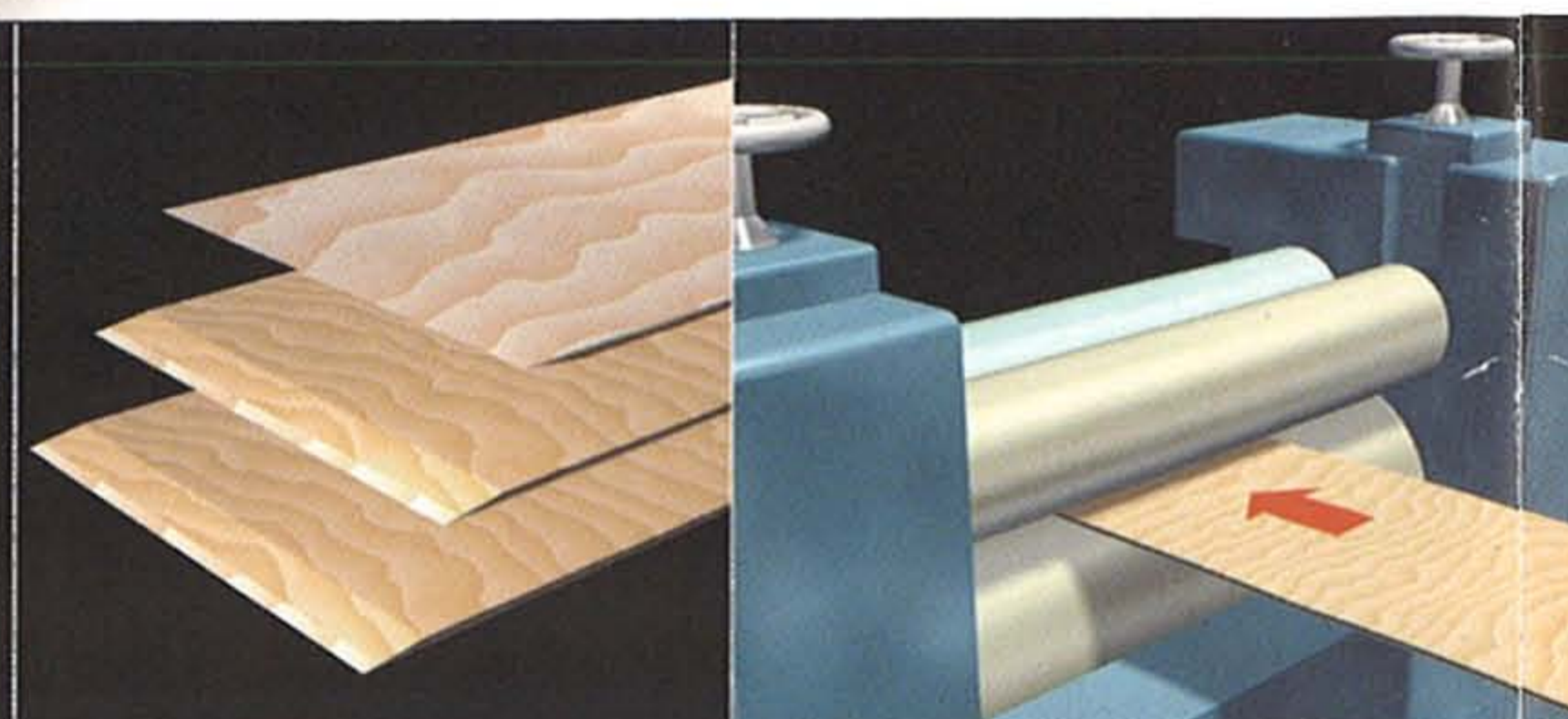
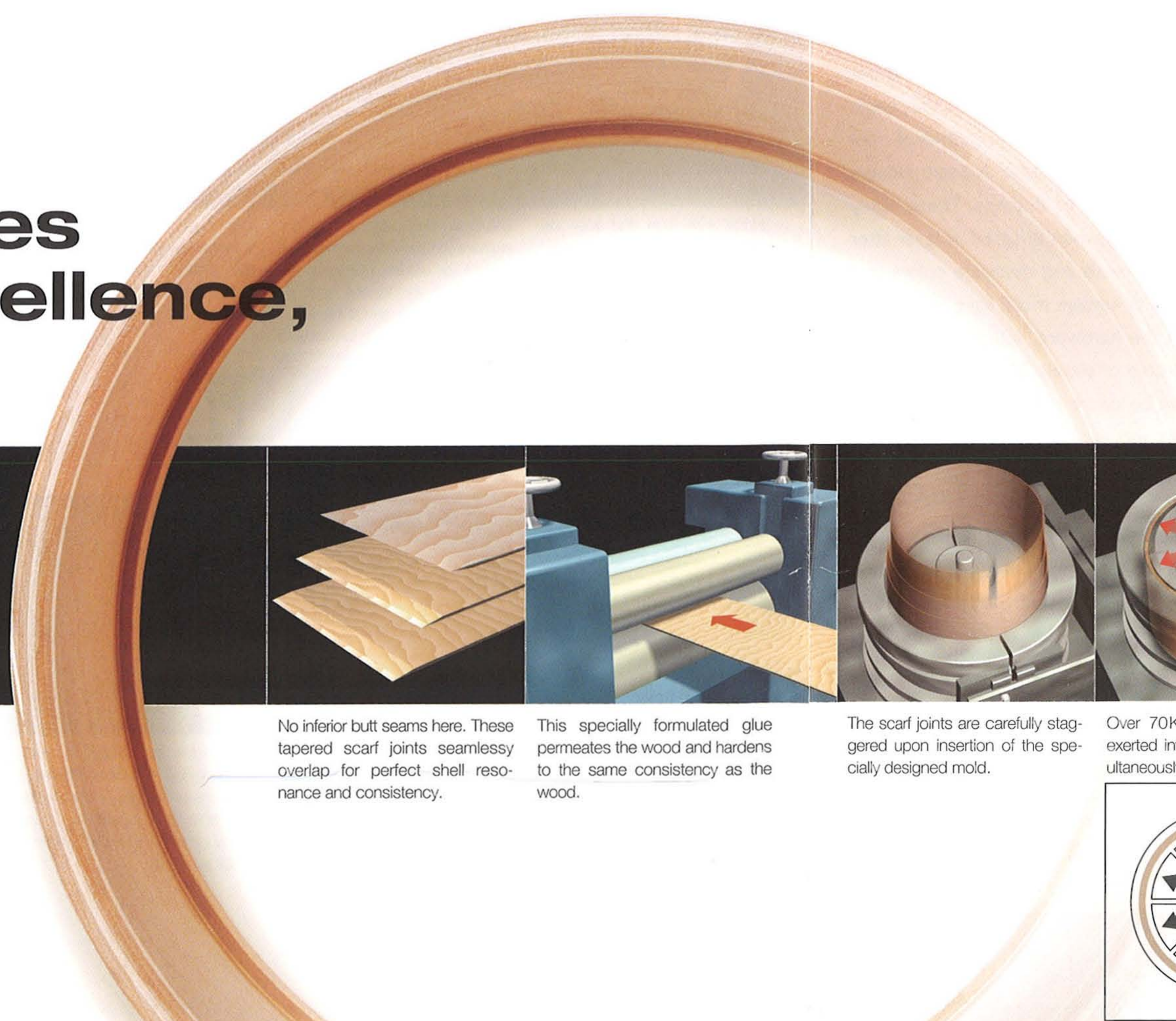

No inferior butt seams here. These tapered scarf joints seamlessly overlap for perfect shell resonance and consistency.

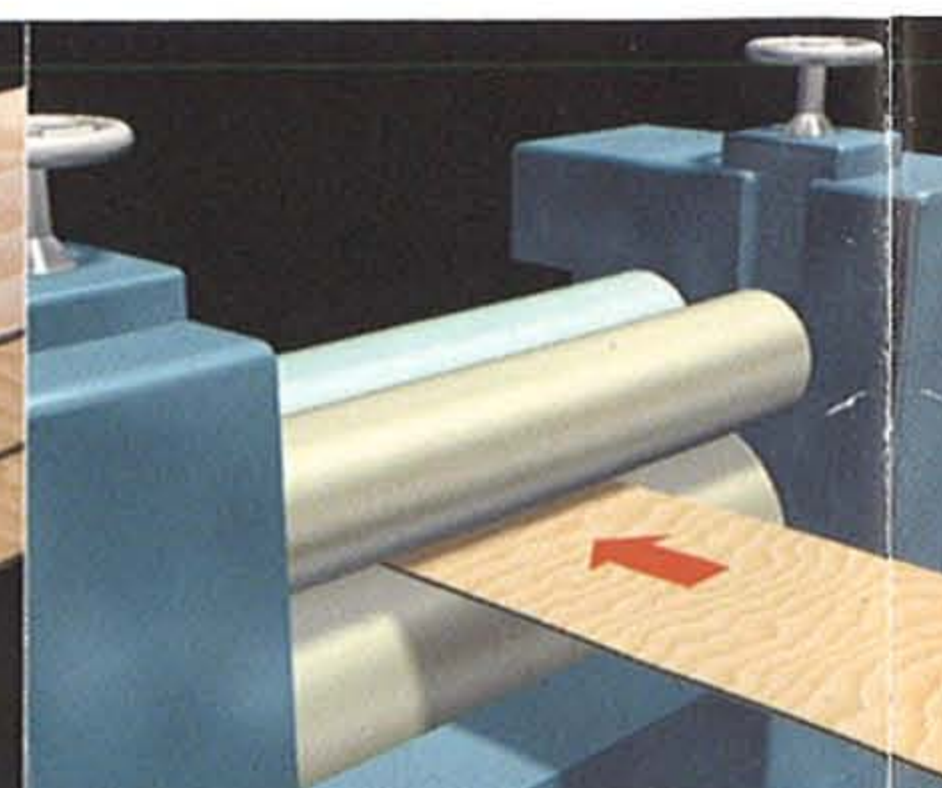

This specially formulated glue permeates the wood and hardens to the same consistency as the wood.

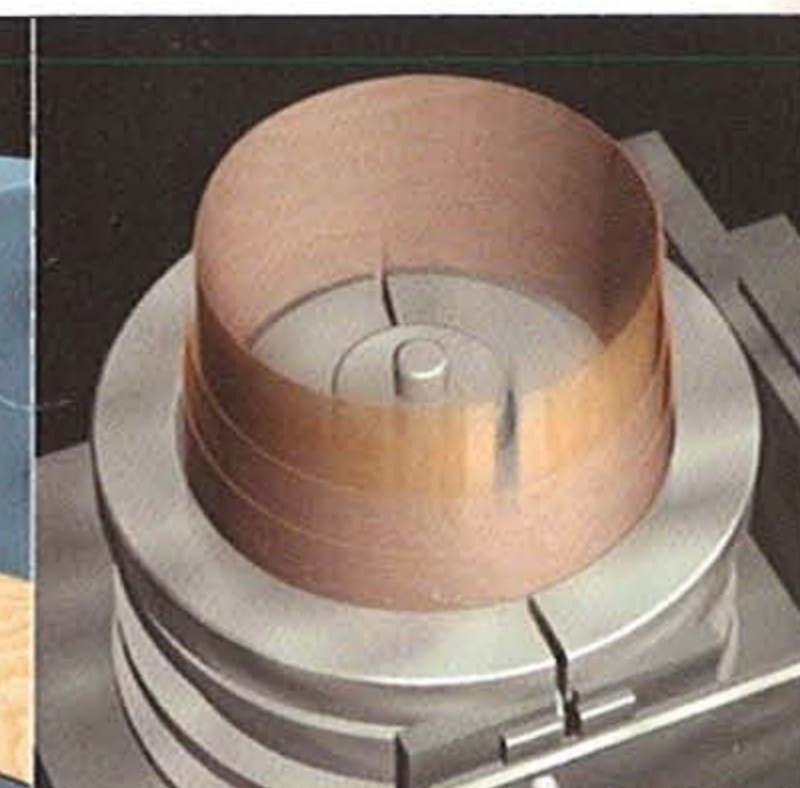

The scarf joints are carefully staggered upon insertion of the specially designed mold.



Over 70Kgf/cm² of pressure is exerted inward and outward simultaneously with extreme heat.

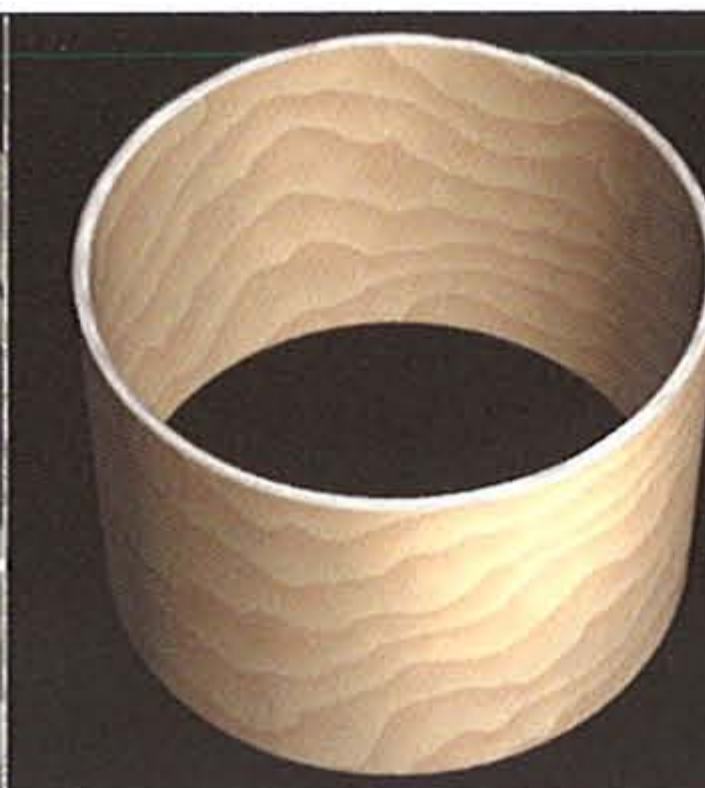

A perfect, gapless air chamber.

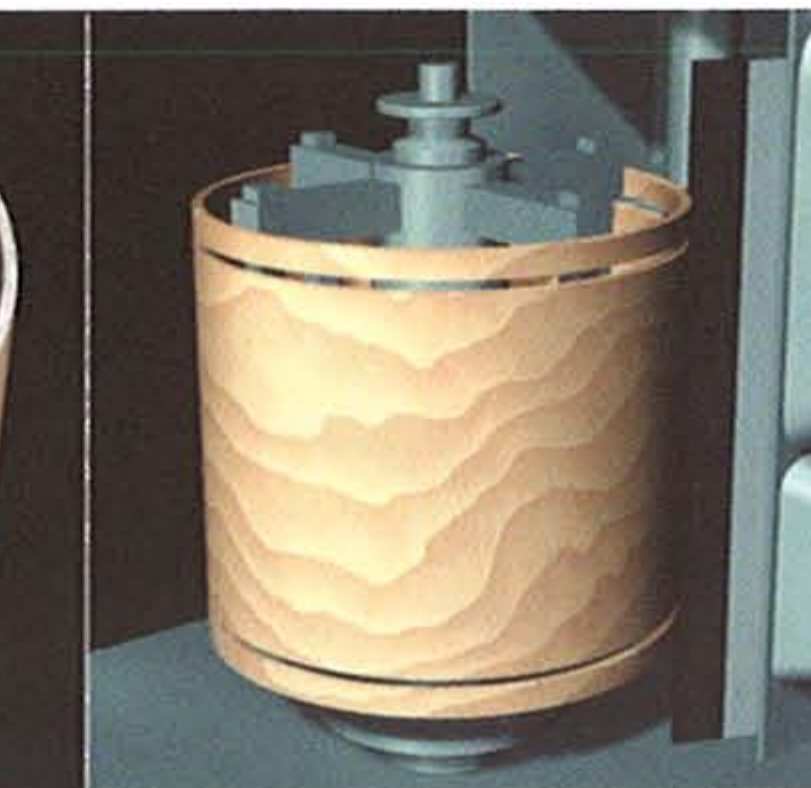

The shell is then trimmed and the ends squared to assure overall tuning consistency and head seal.

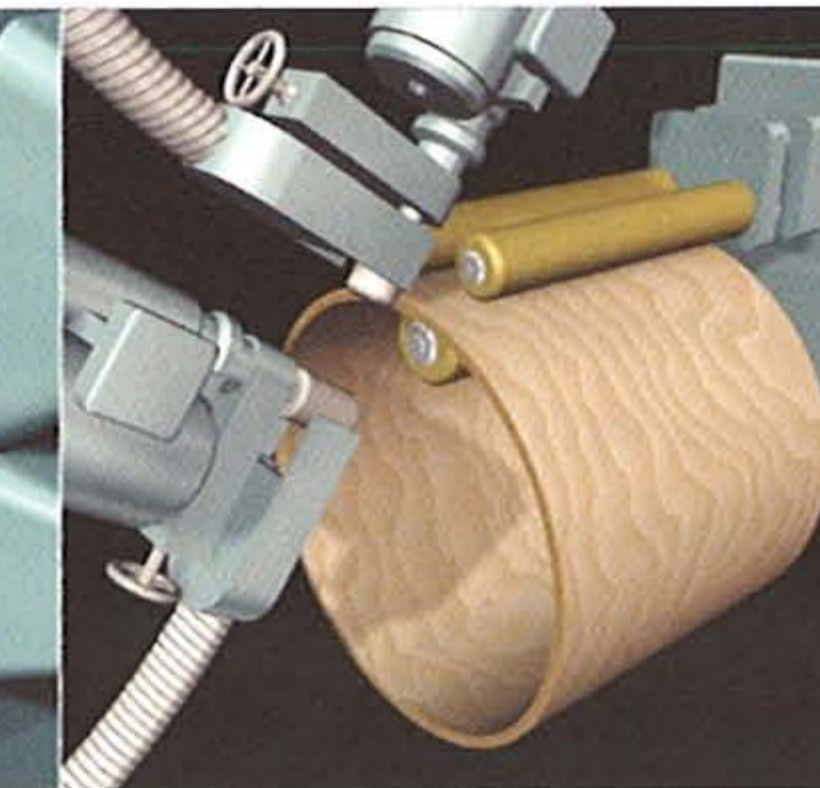

Our exclusive bearing edge incorporates a 45° out and 45° in, slightly inset from the exterior to optimize contact with the flat portion of the drum head.

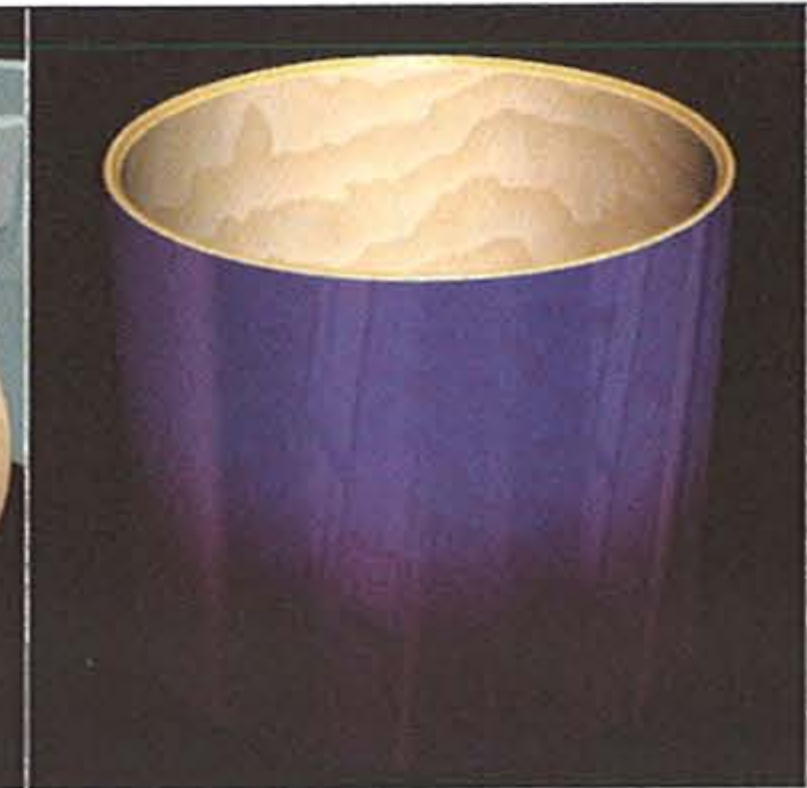

Pearl's finishes are the industry state of the art. Your choice of finish is encased in layers of highly durable urethane and polished to a high luster. Truly a work of art.

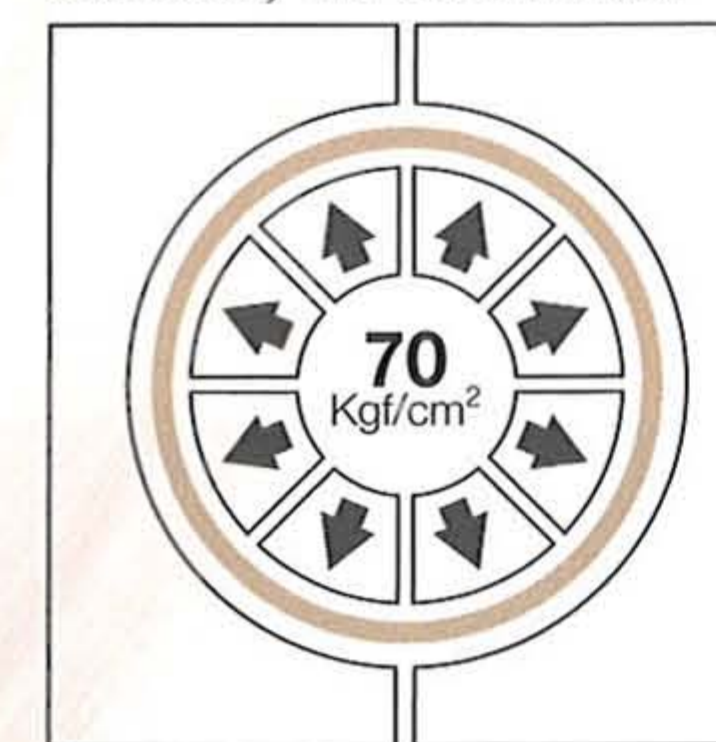

HC/sms
Heat Compression Shell Molding System



Masterworks



Design the kit of your dreams. The choices are yours.

With no assembly line boundaries and no mass production compromises, Masterworks drums truly represent all that is possible. Each drum is a work of art, constructed by seamlessly blending the artisan qualities and wisdom of hand craftsmanship, with the technology and precision of state of the art custom built machinery. There is no inventory. Every drum in your kit is designed by you, and hand built to your exacting specifications, one drum at a time. We've assembled an elite group of Pearl master craftsmen in order to manufacture the finest drums the world has ever known. Masterworks drums are as individual as you are, and like no other you have heard or seen before.



Pearl's Masterworks line of drums represents the fruition of over 50 years of acoustic drum research and craftsmanship. When you choose Masterworks, you're selecting drums that epitomizes exactly what you want in set of drums. Why? Because you design them. From shell thickness and composition, to exterior finish and hardware plating. Masterworks is the only true custom drums available. There is no inventory, no pre-fabricated shells sitting on a shelf. Every drum in your kit is designed by you and built to the most exacting tolerances by the world's finest master craftsmen using the industries most advanced custom built machinery.



Maple, Birch and African Mahogany



Composit Shell

Completely custom. Totally hand-made. It's a musicians dream come true. Whatever your musical style, Masterworks can build a kit to express every nuance of your individual style.

With Masterworks, it's about choices. The choices that begin with the selection of your shell material. You choose the individual plies and any combination of select woods. Even exotic outer Artisan veneers are available such as Red Burl Mahogany, Tamo or Bubinga. These highly figured woods become acoustic masterpieces when encased in layer after layer of high gloss lacquer. We can even match and duplicate colors that you submit. Fades, bursts, opaques, pearls or vintage metal flake finishes are all available. The choices continue with the hardware, select standard lustrous Chrome, Satin Chrome, Black Chrome or stately 24k Gold.

With Pearl's Masterworks Series you can be assured that your drums will be as individual as you are. If you desire something more futuristic, we offer the cutting edge of drums with the Carbon Fiber finish.



This ultra exotic hybrid features 6 plies of 5.4mm Maple shells sandwiched between an inner and outer ply of Carbon Fiber. This kit offers a sound that goes beyond description and has to be experienced. The future is now!

Masterworks Gold Mini Flake Finish

- All Composite Shells with different material
- Gold Mini Flake Finish with Super Hi-Luster Lacquer Top Coat



Masterworks Red fade, Artisan Bubinga Outer Ply

- Composite Shell with Artisan Bubinga Outer Ply
- Red Fade Finish with Super Hi-Luster Lacquer Top Coat

Masterworks Carbonply Maple Finish

- Carbon Fiber Inner and Outer Plies, 6 Ply 5.4mm 100% Maple Core
- Same Pricing as Lacquer Finished Masterworks

This hybrid kit is as futuristic as they come with a sound that is equally ahead of its time. If you feel that you lack "Stage Presence", this kit can make up for it with looks alone. And when you strike the first note, you'll realize what Masterworks is all about.... Unparalleled Quality. Carbonply Maple's distinctive sound results from joining the 6-ply 5.4mm 100% Maple shell with an inner and outer layer of Carbon Fiber. This highly evolved combination creates a sumptuous sonic sandwich that provides a sound and response unlike anything you've ever played before.



Completely Custom. Totally Handmade.



Masters Series is about choices.
 No other Series provides
 so many options in
 shell composition and finishes.
 It's the sound of professionals.
 Make it yours.

THE MASTERS

it's the sound.

MASTERS CUSTOM MMX

MASTERS CUSTOM MRX

MASTERS RETROSPEC MSX

MASTERS STUDIO BRX

MASTERS MAHOGANY CLASSIC MHX

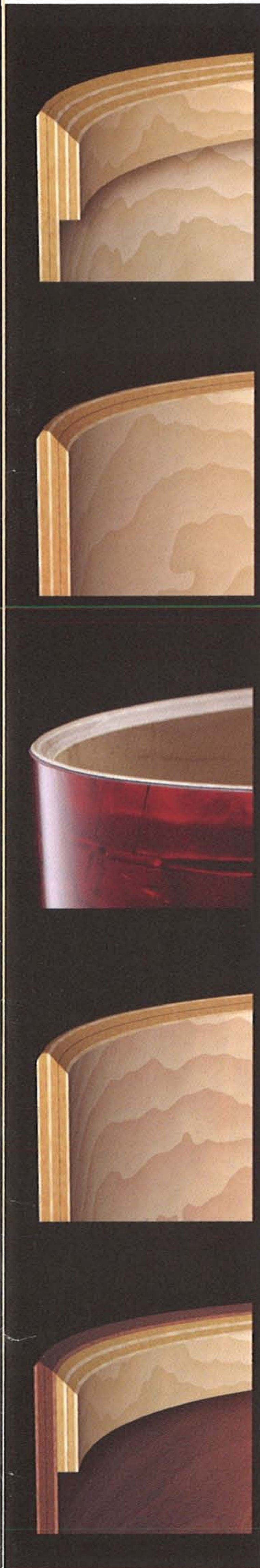

4 ply Maple with 4 ply Maple Reinforcement Rings (5mm + 5mm)

This is the classic "Masters Sound" offering a thin, 4 ply, 5mm, 100% aged Maple shell with reinforcement rings at both top and bottom. This shell provides great response with a full bodied round tone, with smooth sustain and is easy to tune in any range.

6 ply Maple (7.5mm)

This is Pearl's legendary 6 ply, 100% aged Maple shell. It offers an extremely powerful, solid sound, with great focus, volume, and projection. MRX provides a very flexible sound for any type of music offering a great blend of attack and low end presence.

6 ply Maple with Covered Finish (7.5mm)

MSX provides 6 plies of 100% Maple, the same solid, hard-hitting power and projection of MRX but with a durable covered finish. These finishes give the drum the retro look of the classic kits of yesterday.

6 ply Birch (7.5mm)

Our exclusive Masters Studio shell is the perfect alternative to the total Maple sound. Its tone is naturally "EQed" providing great hi-end attack, a slightly reduced mid range, and beautiful low end punch. BRX is a great all around sound for both live and recorded music.

4 ply Mahogany with 4 ply Maple Reinforcement Rings (5mm + 5mm)

Our African Mahogany MHX provides an extremely warm, mellow, and deep round tone, with great response. Its sound is very natural and offers the ultimate in low end. The sound of MHX is very reminiscent of the prized vintage drums of yesteryear.

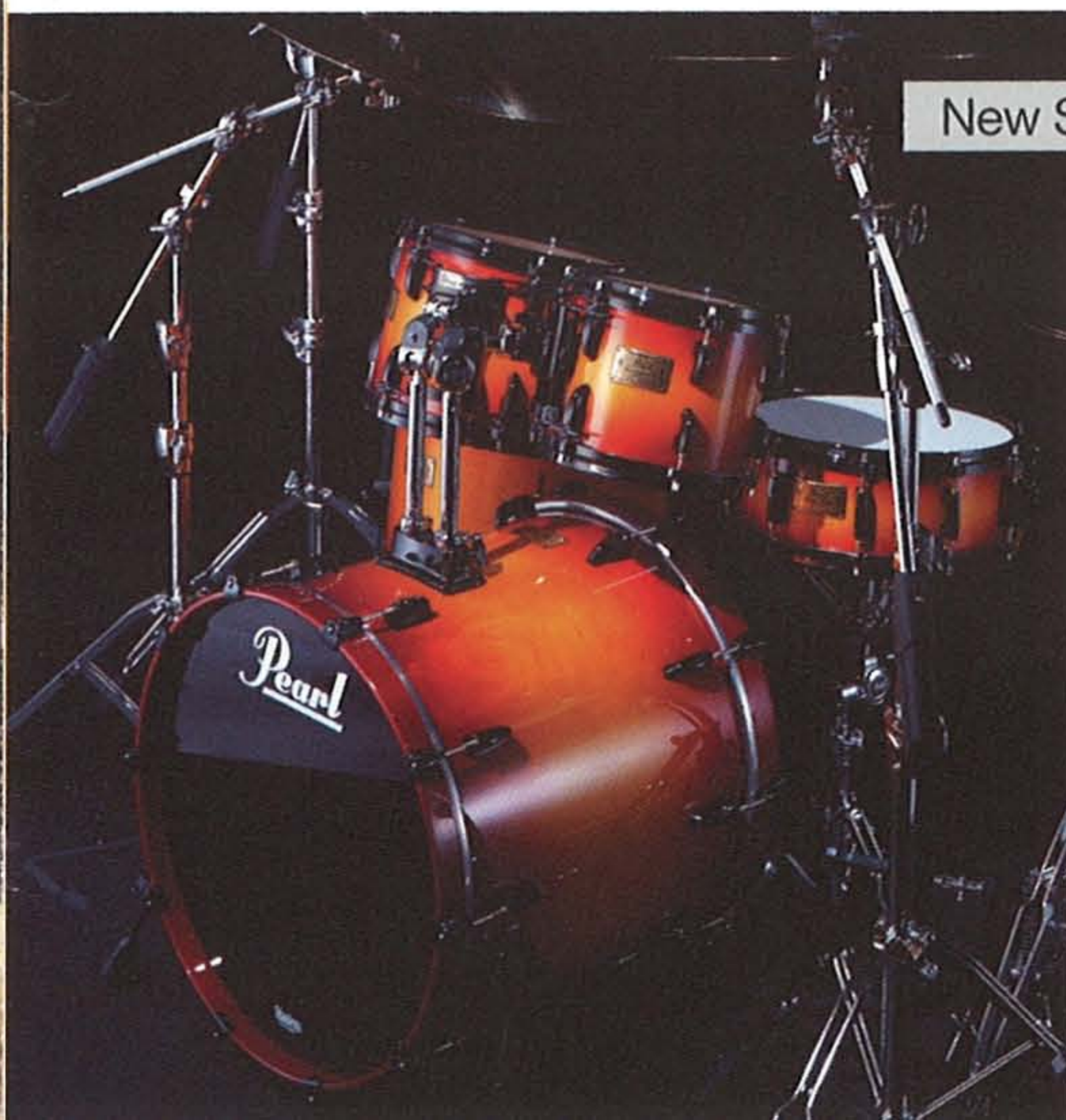

New Super Deep Bass Drums

Meeting the trend for deeper bass drums, we are now offering 20" depth on 22" diameter bass drums to create an even, full bodied, and deeper tone without losing sustain. The new depth will be offered as an ala cart choice with Masterworks, Reference and Masters Series drums.

Hardware Color

Pearl continues its legacy of innovation by offering drummers four additional choices to make their kit as unique as they are. All Masters Series drums are available in your choice of Chrome, Gold, Satin Chrome, or Black Chrome plated hardware finishes.

Gold Plated Hardware
in #151 Platinum Mist



Satin Chrome Plated Hardware
in #168 Ocean Sparkle



Black Chrome Plated Hardware
in #154 Midnight Fade



Model Number

Specification Chart

Diameter x Depth	Size Code #	
Bass Drum	w/o BB-3	w/ BB-3
18" x 14"	1814BX	1814BB
18" x 16"	1816BX	1816BB
20" x 14"	2014BX	2014BB
20" x 16"	2016BX	2016BB
20" x 18"	2018BX	2018BB
22" x 16"	2216BX	2216BB
22" x 18"	2218BX	2218BB
22" x 20"	2220BX	2220BB
24" x 16"	2416BX	2416BB
24" x 18"	2418BX	2418BB
Floor Tom		
14" x 14"	1414F	
16" x 16"	1616F	
18" x 16"	1816F	
Tom Tom		
8" x 7"	0807T	
8" x 8"	0808T	
10" x 8"	1008T	
10" x 9"	1009T	
10" x 10"	1010T	
12" x 8"	1208T	
12" x 9"	1209T	
12" x 10"	1210T	
13" x 9"	1309T	
13" x 10"	1310T	
13" x 11"	1311T	
14" x 10"	1410T	
14" x 11"	1411T	
14" x 12"	1412T	
15" x 13"	1513T	
15" x 14"	1514T	
16" x 13"	1613T	
16" x 14"	1614T	

Numbering System

Series
 Diameter
 Depth

MMX 22 18 B X / C

Bass Drum **B**
 Floor Tom **F**
 Tom Tom **T**
 Snare Drum **S**

w/o BB-3 **X**
 w/ BB-3 **B**
 Snare Drum w/ Double Lugs ... **D**

Hardware Color **C**
 Chrome Plated **C**
 Black Chrome Plated **B**
 Satin Chrome Plated **S**
 Gold Plated **G**

Masters Series LACQUER Finish

MMX MRX MHX BRX

Model No.	Finish Name
No.100	Wine Red
No.102	Natural Maple
No.103	Piano Black
No.112	Natural Birch
No.122	Black Mist
No.128	Vintage Sunburst
No.141	Red Mahogany
No.148	Emerald Fade
No.151	Platinum Mist
No.152	Antique Gold
No.153	Sunrise Fade
No.154	Midnight Fade
No.156	Purple Storm
No.160	Silver Sparkle
No.165	Diamond Burst
No.166	Black Sparkle
No.168	Ocean Sparkle

Available Colors



Masters Series COVERED Finish

MSX

No.400	White Marine Pearl
No.401	Royal Gold
No.402	Abalone
No.403	Red Onyx
No.404	Amethyst



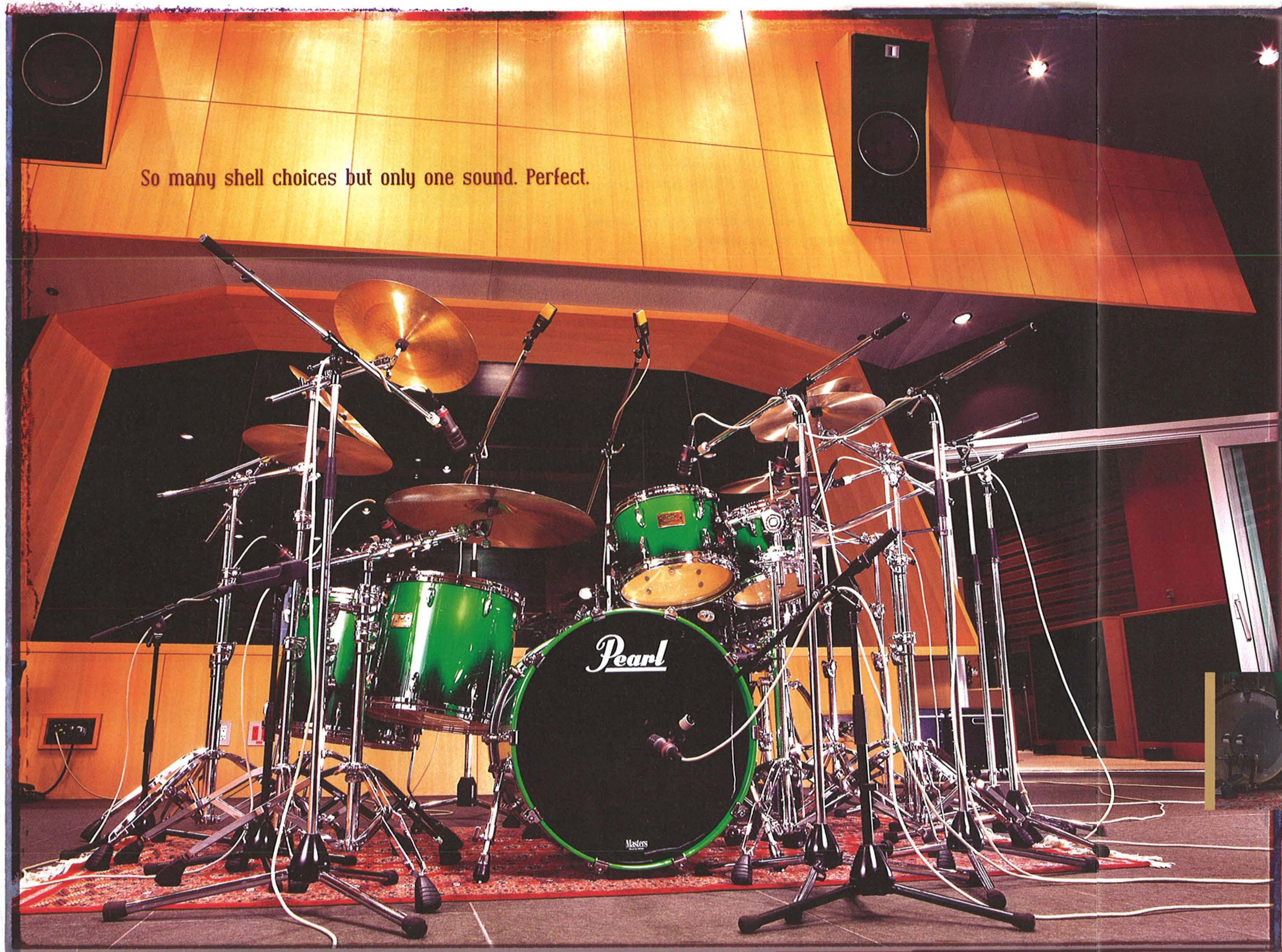

So many shell choices but only one sound. Perfect.

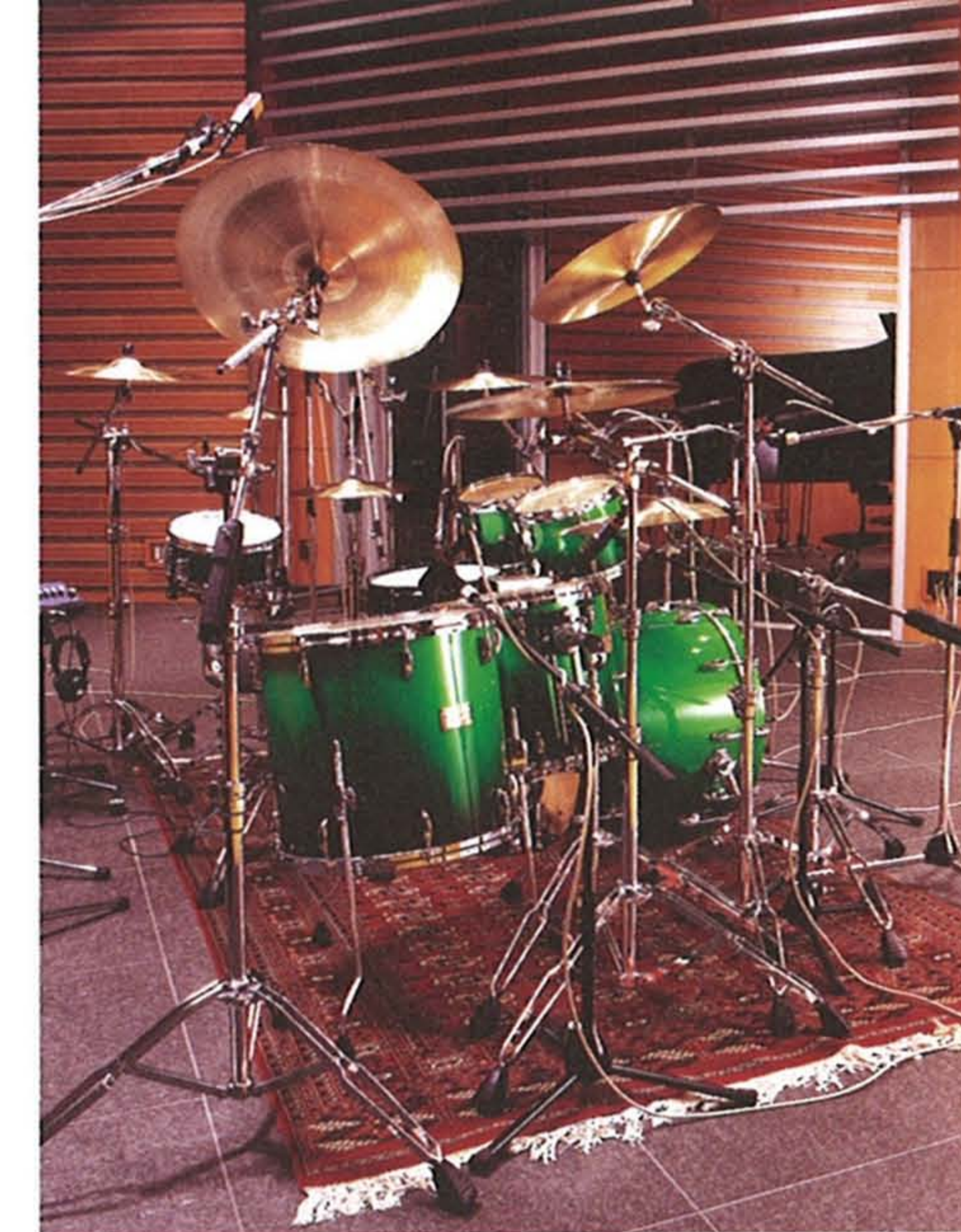

MASTERS CUSTOM MMX

#148 Emerald Fade
 Bass Drum : MMX2218BX/C, MMX2016BX/C
 Tom Tom : MMX1008T/C, MMX1208T/C, MMX1309T/C,
 MMX1412T/C, MMX1614T/C,
 Floor Tom : MMX1816F/C
 Snare Drums : UCA1465, FCP1050
 Hardware & Accessories :
 P-2002C(x2), H-2000, S-2000, T-2000, TX-100, TH-2000S(x2),
 DR-501C(x2), PCX-200(x3), IS-0810N/C, TH-2000I, CH-2000,
 TL-2000, CH-2000S(x4), CH-1000(x2), BA-200BW



Air Suspension feet on our Floor toms allow the shell to fully resonate with minimal dampening. All Masters Series drums feature our Stainless Steel tension rods for strong, consistent tuning. Our recessed bass drum claws offer a smooth appearance while maintaining easy tuning access.

THE MASTERS

Get on the Producer's Speed Dial

Master Series is the first call kit for the professional drummer. With so many choices available, it's no wonder Masters have become one of the favorites in the recording industry. Birch, Maple or Mahogany, whatever your recording dynamics may be, Masters Series has the sound for the application.



MASTERS RETROSPEC MSX

#401 Royal Gold
 Bass Drum : MSX2218BX/C
 Tom Tom : MSX1008T/C, MSX1209T/C, MSX1310T/C
 Floor Tom : MSX1616F/C, MSX1816F/C
 Snare Drum : MSX1465S/C, M1040
 Hardware & Accessories :
 H-2000, P-2002C, S-2000, DR-503, PCX-200(x3),
 TH-2000S(x4), CH-1000(x5)

THE MASTERS

Masters Series, a Force to be Reckoned with on the Stage.

When you see a great drummer, he's usually behind a great kit.
And Masters Series is that kit rocking stadiums and concert halls around the world.
There is no greater stage presence than Masters Series. Let's Rock.

Masters. As strong as you need it to be.

The Masters It's the sound.



MASTERS CUSTOM MMX

#168 Ocean Sparkle
Bass Drum : MMX2418BX/S
Tom Tom : MMX1209T/S
Floor Tom : MMX1616F/S
Snare Drum : SCS1450
Hardware & Accessories :
H-2000, P-2000C, S-2000, BA-200BW,
UX-80, TH-2000S, C-1000(x3)



MASTERS RETROSPEC MSX

#404 Amethyst
Bass Drum : MSX2218BX/C
Tom Tom : MSX0807T/C, MSX1008T/C, MSX1209T/C
Floor Tom : MSX1414F/C, MSX1616F/C
Snare Drums : MSX1465S/C
Hardware & Accessories :
H-2000, P-2002C, S-2000, DR-501C, DR-501CE(x2),
PCX-100(x2), PCX-200(x4), CH-2000, CH-1000(x4),
75X, BCM-10, TH-2000S(x3), TL-2000(x2)



MASTERS RETROSPEC MSX

#403 Red Onyx
Bass Drum : MSX2416BX/B
Tom Tom : MSX1310T/B
Floor Tom : MSX1616F/B, MSX1816F/B
Snare Drum : UCA1450
Hardware & Accessories :
H-2000, P-2000C, S-2000, BA-200BW, TX-100,
TH-2000S, B-1000(x5)



MSX offers that proven 6 ply 100% Maple sound in choice of 5 covered finishes. These finishes are visually stunning and highly durable, making them perfect for the road. Features like matching inlays on the bass hoops and Pearl's OptiMount Tom mounting system let you know that this is a Masters Series.

The Masters

It's the sound.

MMX MRX MSX MHX BRX



MASTERS CUSTOM MMX

#153 Sunrise Fade
 Bass Drum : MMX2016BB/C
 Tom Tom : MMX1008T/C, MMX1209T/C
 Floor Tom : MMX1414F/C
 Snare Drums : SCS1450
 Hardware & Accessories :
 H-1000, P-1000, S-1000, TH-2000(x2), B-1000(x2), C-1000(x3)



MASTERS CUSTOM MMX

#156 Purple Storm
 Bass Drum : MMX2218BB/S
 Tom Tom : MMX1008T/S, MMX1209T/S, MMX1412T/S, MMX1614T/S
 Snare Drums : MMX1455S/S
 Hardware & Accessories :
 H-2000, P-2002C, S-2000, T-2000(x2), BC-2000, C-1000(x3),
 B-1000, AX-20, CLH-1000, TL-2000



MASTERS CUSTOM MRX

#122 Black Mist
 Bass Drum : MRX2218BB/C
 Tom Tom : MRX1209T/C, MRX1310T/C
 Floor Tom : MRX1616F/C
 Snare Drum : STS1455
 Hardware & Accessories :
 H-1000, P-1002, S-1000, TH-1000(x2), B-1000(x2), C-1000(x3)



MASTERS STUDIO BRX

#128 Vintage Sunburst
 Bass Drum : BRX2218BB/B(x2)
 Tom Tom : BRX0807T/B, BRX1008T/B, BRX1009T/B, BRX1208T/B,
 BRX1210T/B
 Floor Tom : BRX1411T/B, BRX1613T/B, BRX1816F/B
 Snare Drum : BRX1465S/B
 Hardware & Accessories :
 RH-2000, P-2000C(x2), S-2000, DR-501C(x2), DR-501CE(x2),
 RJ-50, CH-2000(x2), CH-2000S(x2), CH-1000(x7), TH-2000S(x6),
 TH-2000I(x2), TL-2000(x3), PCX-100(x9), PCX-200(x7), AX-25,
 PBL-20, BCM-10,



MASTERS RETROSPEC MSX

#400 White Marine Pearl
 Bass Drum : MSX2016BB/S
 Tom Tom : MSX1209T/S
 Floor Tom : MSX1414F/S, MSX1616F/S
 Snare Drum : MSX1455S/S
 Hardware & Accessories :
 H-2000, P-2000B, S-1000, AX-20, TH-2000S, B-1000(x2), C-1000(x2)



MASTERS MAHOGANY CLASSIC MHX

#141 Red Mahogany
 Bass Drum : MHX2218BB/C
 Tom Tom : MHX1310T/C,
 Floor Tom : MHX1616F/C, MHX1816F/C
 Snare Drums : MHX1465S/C
 Hardware & Accessories :
 H-2000, P-1000, C-1000(x3), B-1000, BC-2000, PTM-10GH, PPS-37



MASTERS STUDIO BRX

#100 Wine Red
 Bass Drum : BRX2016BB/C
 Tom Tom : BRX1209T/C
 Floor Tom : BRX1616F/C
 Snare Drum : BRX1455S/C
 Hardware & Accessories :
 H-2000, P-2000C, S-2000, BA-200BW, TX-100, TH-2000S, B-1000(x4),
 AX-25L, 75X, PTM-10GH, CA-100, ECB-6

THE MASTERS

The Masters ... It's the sound.

Masters. The most innovative, most versatile drums ever designed.
Specially built for the way you play now.

THE MASTERS

Masters Series is the professional's choice.

And to make your Masters kit complete be sure and use only the finest hardware, Pearl. Our all new 2000 Series hardware represents years of research and development in hardware engineering. From our ICON racks used by the most prolific drummers in the world to our Powershifter Eliminator pedals, our mind set of manufacturing excellence is evident in every component that we make.

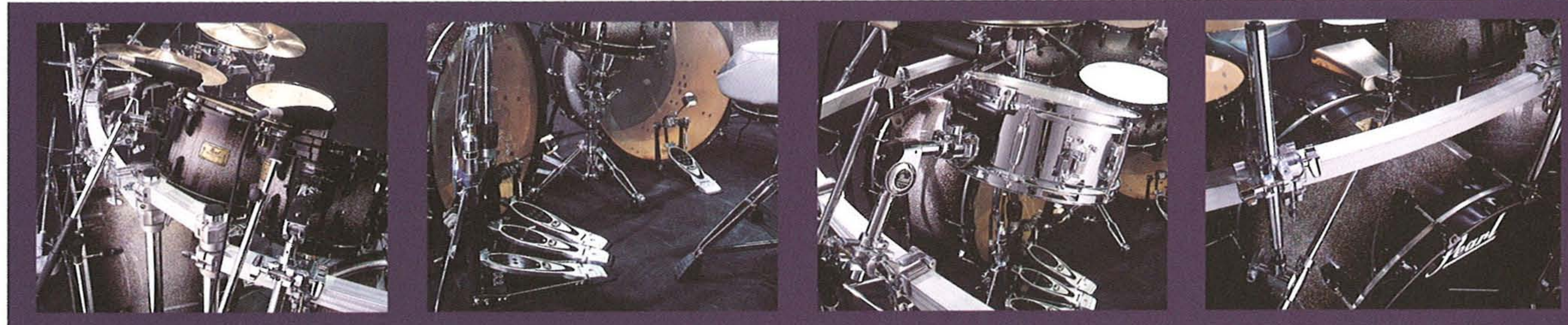

MASTERS CUSTOM MMX

#165 Diamond Burst

Bass Drum : MMX2418BX/B(x2), MMX2016BX/B
 Tom Tom : MMX1008T/B, MMX1209T/B, MMX1411T/B
 Floor Tom : MMX1616F/B, MMX1816F/B
 Snare Drum : MMX1465SD/B, FCS1250
 Hardware & Accessories :
 H-2000, HA-100, CLH-1000, P-2000C(x2),
 P-2002C, S-2000, DR-501C(x2), DR-501CE(x2),
 RJ-50, PCX-200(x4), PCX-100(x4), TH-2000S(x4),
 IS-0810N/C, TH-2000(x2), CH-2000(x2), CH-1000(x7),
 AL-612, AL-615



MASTERS CUSTOM MRX

#151 Platinum Mist

Bass Drum : MRX2218BX/C
 Tom Tom : MRX1008T/C, MRX1209T/C
 Floor Tom : MRX1414F/C, MRX1616F/C, MRX1816F/C
 Snare Drum : STS1455
 Hardware & Accessories :
 H-2000, P-2002B, S-2000, DR-503, PCX-200(x3), TH-2000S(x2),
 CH-2000, TL-2000, CH-2000S(x4), 75(x2), PTM-10GH, BCM-5



MASTERS RETROSPEC MSX

#402 Abalone

Bass Drum : MSX2218BB/C
 Tom Tom : MSX1209T/C
 Floor Tom : MSX1616F/C
 Snare Drum : CS1450
 Hardware & Accessories :
 H-1000, P-1000, S-1000, TH-1000I, BC-2000, TL-2000,
 B-1000(x4), PTM-10GH



ROCKET TOMS

Rocket Toms are the perfect accent for your kit and can be melodically tuned for dramatic fills.

6" x 12"	AL-612
6" x 15"	AL-615
6" x 18"	AL-618
6" x 21"	AL-621

#103 Piano Black Lacquer, #109 Arctic White Lacquer



JUNGLE GIG

The Jungle Gig allows the conversion of virtually any 16" floor to a bass drum. Very portable and perfect for small gig.

Jungle Gig Kit	JG-16
----------------	-------



High end Features at a Mid Range Price

SESSION

SESSION CUSTOM SMX
ALL MAPLE SHELL

SESSION STUDIO SBX
ALL BIRCH SHELL



#292 Marine Blue Fade



SESSION STUDIO SBX

#282 Storm Cloud

Basic Kit : SBX924HP/C

Additional Set-up : SBX0807T/C, SBX1310T/C, SBX1616F/C, SBX1816F/C, STS1455, FCS1050
DR-501C(x2), H-1000, P-1002, S-1000(x2), UX-80(x3), TH-1000(x2), TX-100(x2), PCX-200(x5),
CH-1000(x6), PS-85, DCL-300P, RH-2000, AX-20 (x2), CLH-1000



SESSION STUDIO SBX

#289 Blue Burst

Bass Drum : SBX2218BB/C

Tom Tom : SBX1008T/C, SBX1209T/C, SBX1310T/C

Floor Tom : SBX1414F/C, SBX1616F/C

Snare Drum : STS1455

Hardware & Accessories : H-1000, P-1002, S-1000, B-1000(x4), C-1000(x2), CH-1000,
T-1000, TH-1000I, AX-25L, AX-20,



SESSION CUSTOM SMX

#291 Cranberry Fade

Bass Drum : SMX2218BB/C

Tom Tom : SMX1008T/C, SMX1209T/C

Floor Tom : SMX1414F/C, SMX1616F/C

Snare Drum : UCA1465

Hardware & Accessories :

H-1000, P-1002, S-1000, T-1000, CH-1000, CH-70, B-1000(x4)



SESSION CUSTOM SMX

#290 Vintage Fade

Bass Drum : SMX2016BB/C

Tom Tom : SMX1209T/C

Floor Tom : SMX1414F/C

Snare Drum : STB1455

Hardware & Accessories :

H-1000, P-1000, S-1000, TH-1000I, B-1000, C-1000(x2)



Session Series continues to offer a professional kit packed with features and value.

The Session Series has completely redesigned Lugs, Tom Arms and our state of the art

Tom mounting system, OptiMount. And if that's not enough, now there's a choice

in shell composition in Session. Choose from 6 plies of 100% Maple or 6 plies of 100% Birch.

No matter your choice, you get high end, professional functionality with an affordable price.

- 6 ply 7.5mm 100 % Maple Shells
- New Lug Design
- New Tom Arms
- OptiMount Tom Mounting System
- 5 Super High Gloss Lacquer Finishes



Session Custom SMX | All Maple Shell

Session SMX features 6 plies of 100% Maple. A time proven favorite, Maple delivers that warm resonance and deep sonic punch without compromising sensitivity. Ideal for most any live situation. SMX is available in a choice of 5 high gloss lacquer finishes including 4 dramatic fades.



Session Studio SBX | All Birch Shell



Session SBX offers up a popular choice in shells with 6 plies of 100% Birch. This material has become a favorite in the studio with a lively, easy to record sound. Dramatic highs combined with strong and resonant bottom end delivers a naturally equalized sound. SBX is available in 5 high gloss lacquer finishes including 3 beautiful fades.



Session Series offers professional features and a choice of shell materials.

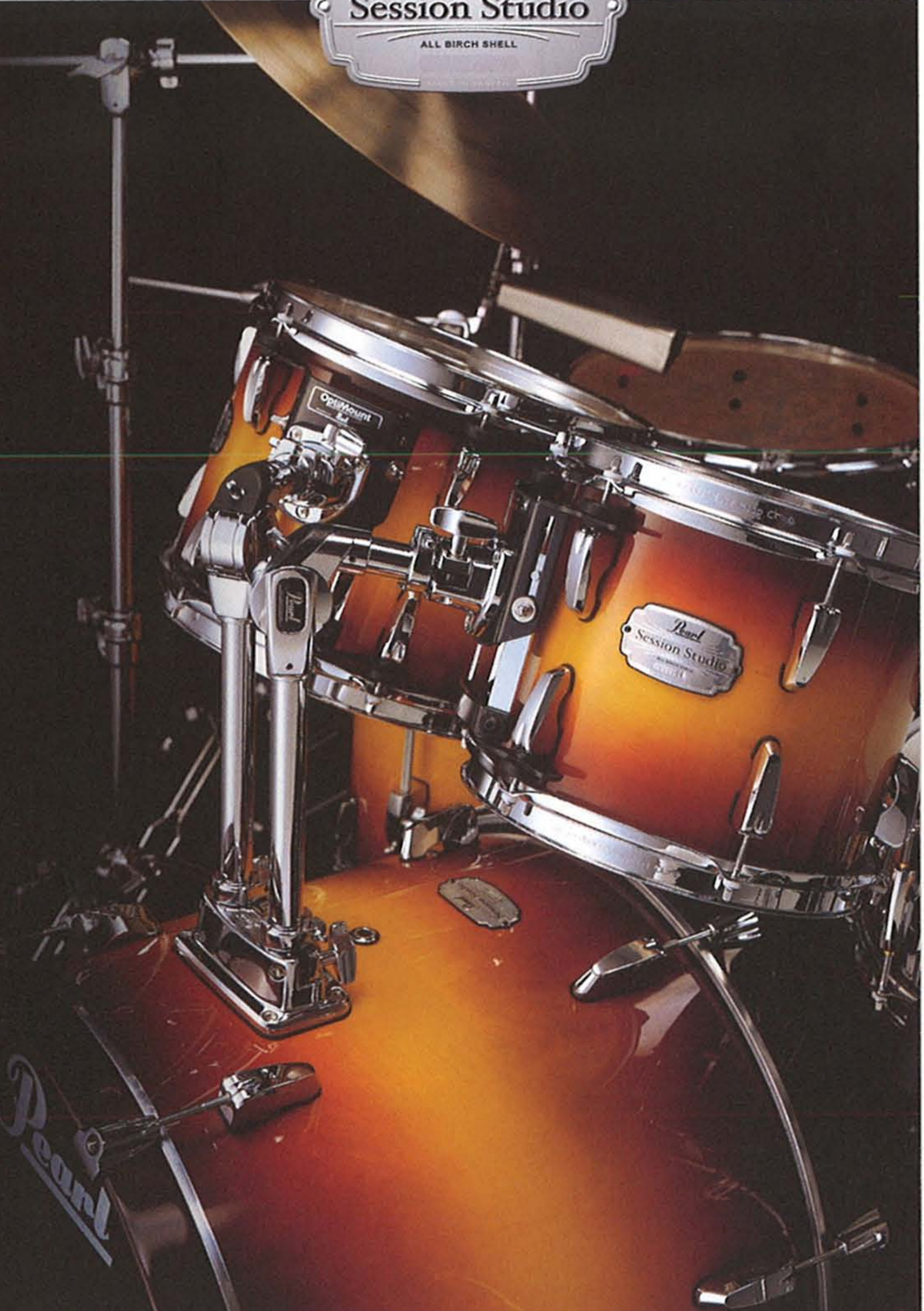

SESSION CUSTOM SMX

#296 Green Burst
Basic Kit : SMX924P/C (4-pc Shell Pack)
Additional Set-up : SMX1414F/C, STB1455
H-1000, P-1000, S-1000, C-1000 (2), B-1000 (3)

SESSION STUDIO SBX

#284 Tobacco Burst
Basic Kit : SBX924P/C (4-pc Shell Pack)
Additional Set-up : SBX1008T/C, SBX1816F/C, STS1455
H-1000, P-1000, S-1000, C-1000 (2), B-1000 (5), TH-1000S, AX-20, BCM-8



Both Session Series offer 3 best selling configuration shell packs. The 924HP provides bright and beautiful sounding smaller size tom-toms and hanging-style low tom-tom. The 924P offers the most popular configuration in today's Rock/Pop scene. The 904P has a 20 inch bass drum which delivers you a deep & punchy bass. These shell packs will be your groundwork to build your dream Kit.

SMX924P/C
4-pc Shell Pack *
#281 Carbon Mist

SBX924P/C
4-pc Shell Pack *
#289 Blue Burst

* Hardware, cymbals and snare drum not included



Session Series Shell Packs:

Model #:	924HP	924P	904P
Bass Drum	22"x18" 2218BB	22"x18" 2218BB	20"x16" 2016BB
Tom Toms	10"x 8" 1008T 12"x 9" 1209T 14"x11" 1411T	12"x 9" 1209T 13"x10" 1310T -	10"x 8" 1008T 12"x 9" 1209T -
Floor Tom	-	16"x16" 1616F	14"x14" 1414F
Tom Holder	TH-1000I (2)	TH-1000I (2)	TH-1000I (2)
Tom Holder, Short Adapter	TH-1000S AX-20	-	-
Floor Tom Legs	-	LG-40(3)	LG-40(3)

Component Drums :

Bass Drums	Tom Toms
18" x 14" 1814BB	8" x 7" 0807T
18" x 16" 1816BB	8" x 8" 0808T
20" x 16" 2016BB	10" x 8" 1008T
22" x 16" 2216BB	10" x 9" 1009T
22" x 18" 2218BB	10" x 10" 1010T
24" x 16" 2416BB	12" x 8" 1208T
24" x 18" 2418BB	12" x 9" 1209T
	12" x 10" 1210T
Floor Toms	13" x 9" 1309T
14" x 14" 1414F	13" x 10" 1310T
16" x 16" 1616F	13" x 11" 1311T
18" x 16" 1816F	14" x 11" 1411T
	14" x 12" 1412T
Snare Drums	15" x 13" 1513T
14" x 5.5" 1455S	15" x 14" 1514T
14" x 6.5" 1465S	16" x 13" 1613T
	16" x 14" 1614T

- Size : Diameter x Depth
- Bass Drums w/BB-3 Bracket
- Tom Toms w/OptiMount System

BUILT TO ROCK. BUILT TO LAST

EXPORT



#299 Cobalt Fade

Export Series. Ask any drummer working today and most of them will tell you that it all started with their first Export Kit. Since Export Series hit the Rock scene 20 years ago it has continued to redefine what an entry level kit should be. The evolution continues with a newly engineered lug for the entire family of Export Series. The new P-120P pedal offers styling cues from our award winning Eliminator line of high performance pedals, and the new H-820W Hi-Hat brings speed and response never before available at this price. New to the Export Line is EXR, the defiant black sheep of the Export family. EXR offers bold styling that gets you noticed sonically and visually. 6 outrageous coverings, 1 very difficult choice for you. Export Series, from the garage to the stage, we perform.

PEARL DRUMS EXPORT SERIES		
EXPORT SELECT	EXPORT	EXPORT
ELX	ELX	ELX

EXPORT SELECT ELX #298 Black Burst

Basic Configuration: ELX825B/C
 Additional Set-up: ELX1414F/B, ELX1816F/B, B-800W(x2), BC-800W(x2)



EXPORT SELECT ELX #297 Green Fade

Bass Drum : ELX2218B/C
 Tom Tom : ELX1008T/C, ELX1209T/C, ELX1411T/C, ELX1613T/C
 Snare Drums : ELX1455S/C, FCP1050, FCS1250
 Hardware & Accessories :
 IS-0810N/C, IS-1216N/C, H-820W, RH-2000, P-122TW, PS-85, S-800W, DR-501C(x2), PCX-100, PCX-200(x4), CH-80(x6), TH-88S(x2), TH-88L(x2), UX-80(x2), UX-80S, PPS-15(x2), PPS-37(x3), CA-100, 75X, AX-25, PBL-10, PBL-20, PBL-30, PTB-10, PTM-10GH, BCM-8

ELX provides all of the standard Export features and offers a choice of 8 different high gloss lacquer finishes, three of these beautiful fades are available with Black hardware for a completely custom look. These kits provide the look and style of kits costing hundreds more and a sound to match. ELX, time proven performance.

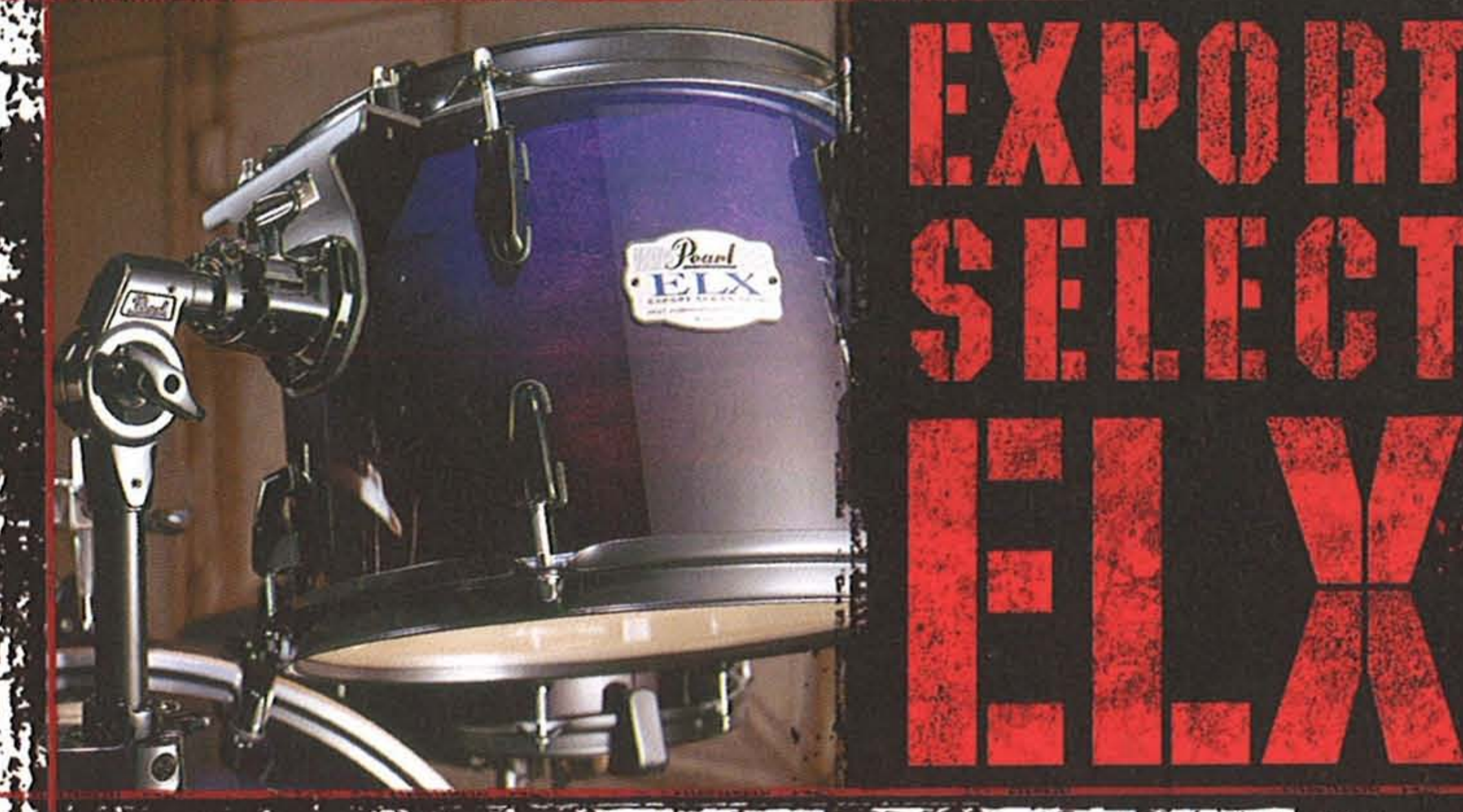

EXPORT SELECT ELX



EXPORT SELECT ELX #294 Amber Fade

Basic Configuration: ELX825H/B, ELX6F/B
 Additional Set-up: BC-800W(x2), FCS1250, UX-80S, CST-80, IS-1216N/C



EXPORT SELECT ELX #295 Ruby Fade

ELX825/C



#431 Strata Black



EXPORT EXR #436 Strata Red
 Basic Kit : **EXR825H/C**
 Additional Set-up : EXR1616F/C, DR-501, DR-501E, PCX-200(x3), CH-80(x3), 75X, ECB-6



EXPORT EXR #433 Strata White
EXR825/C

EXPORT EXR

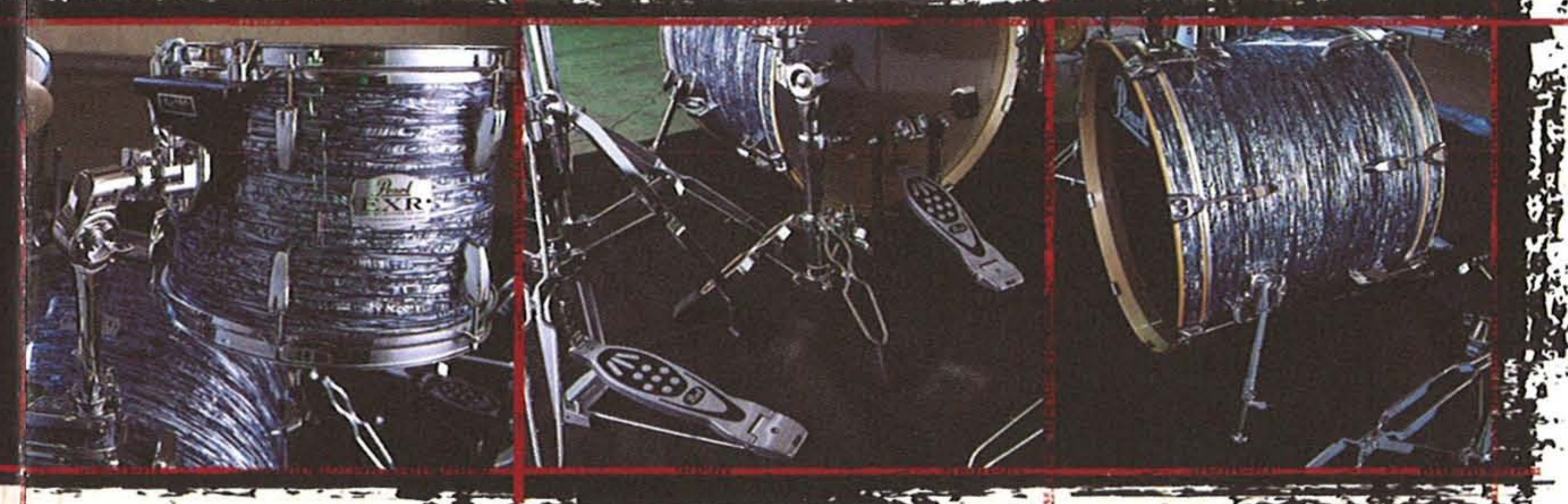

BUILT TO ROCK. BUILT TO LAST



EXPORT EXR #432 Prizm Purple
 Bass Drum : EXR2218B/C
 Tom Tom : EXR1209T/C
 Floor Tom : EXR1616F/C
 Snare Drum : EXR1455S/C, FCP1050
 Hardware & Accessories : H-820W, P-120P, S-800W, B-800W, BC-800W, C-800W(x2)
 CH-80, TH-88I, UX-80, CA-100, ECB-6, IS-0810N/C



The EXR series is the definitive Export series kit. Its 100% Poplar shells covered in a choice of 6 road ready covered finishes exude raw rock power. Setting off the bold exteriors are new lugs, our I.S.S. Tom mounts and a new lightning fast Bass Pedal and Hi-Hat. Never has so much performance and value been available at this price. EXR, your modern monster of rock.

EXPORT EXR #430 Prizm Blue
EXR825/C
 Additional Set-up : EXR2218B/C, EXR1008T/C, EXR1411T/C, P-120P, BC-800W(x3), TH-88I, TH-88S, AX-20, HA-100, PPS-37, ECB-10



EXPORT EXR #435 Strata Blue
 Basic Kit : **EXR825/C**
 Additional Set-up : EXR6/C, S1330B, BC-800W, B-800W, S-800W, CH-70

FORUM READY - SET - GO!!
 IF YOU'RE READY TO ROCK...
 YOU'RE READY FOR FORUM.

FORUM FX

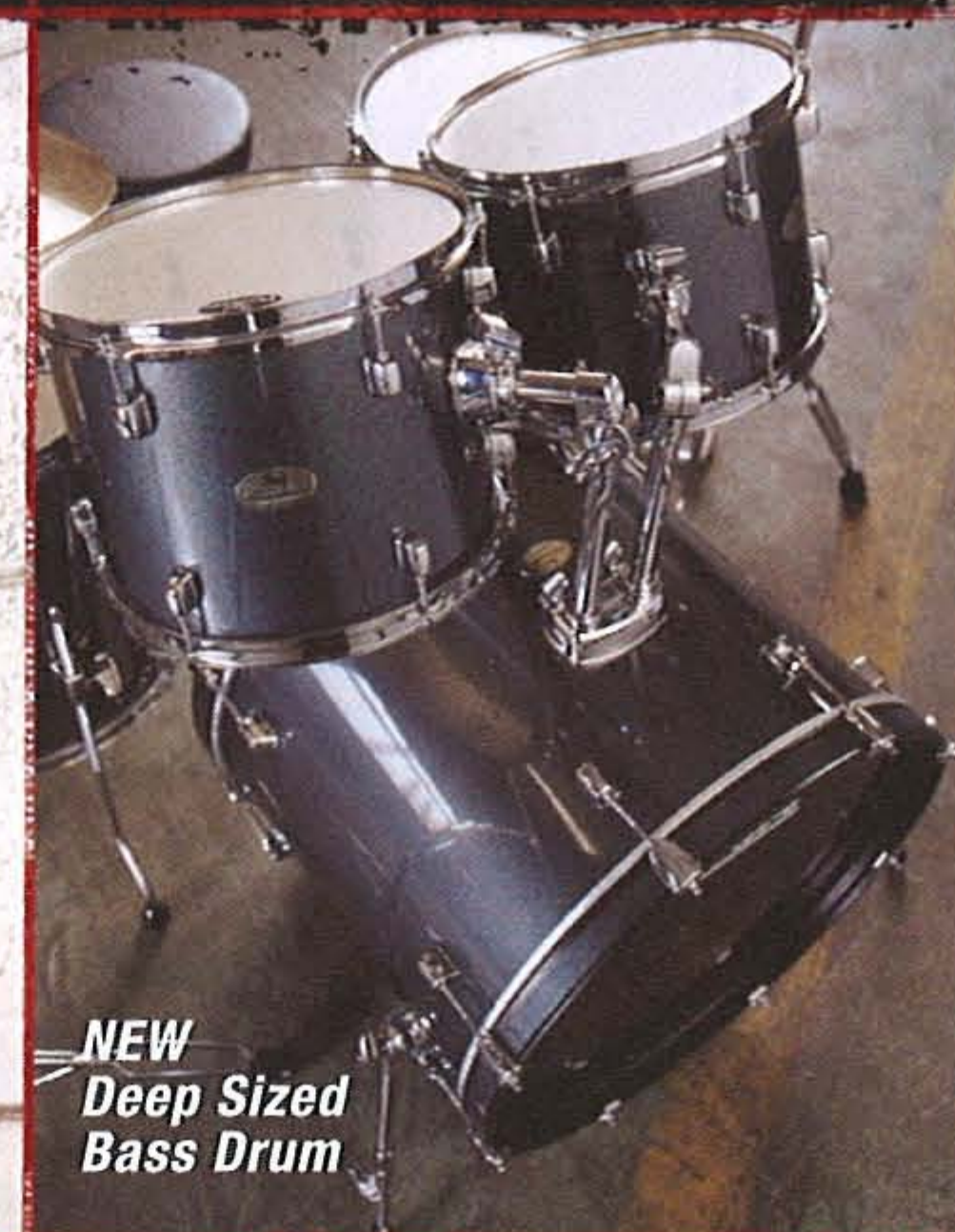

NEW
 Deep Sized
 Bass Drum

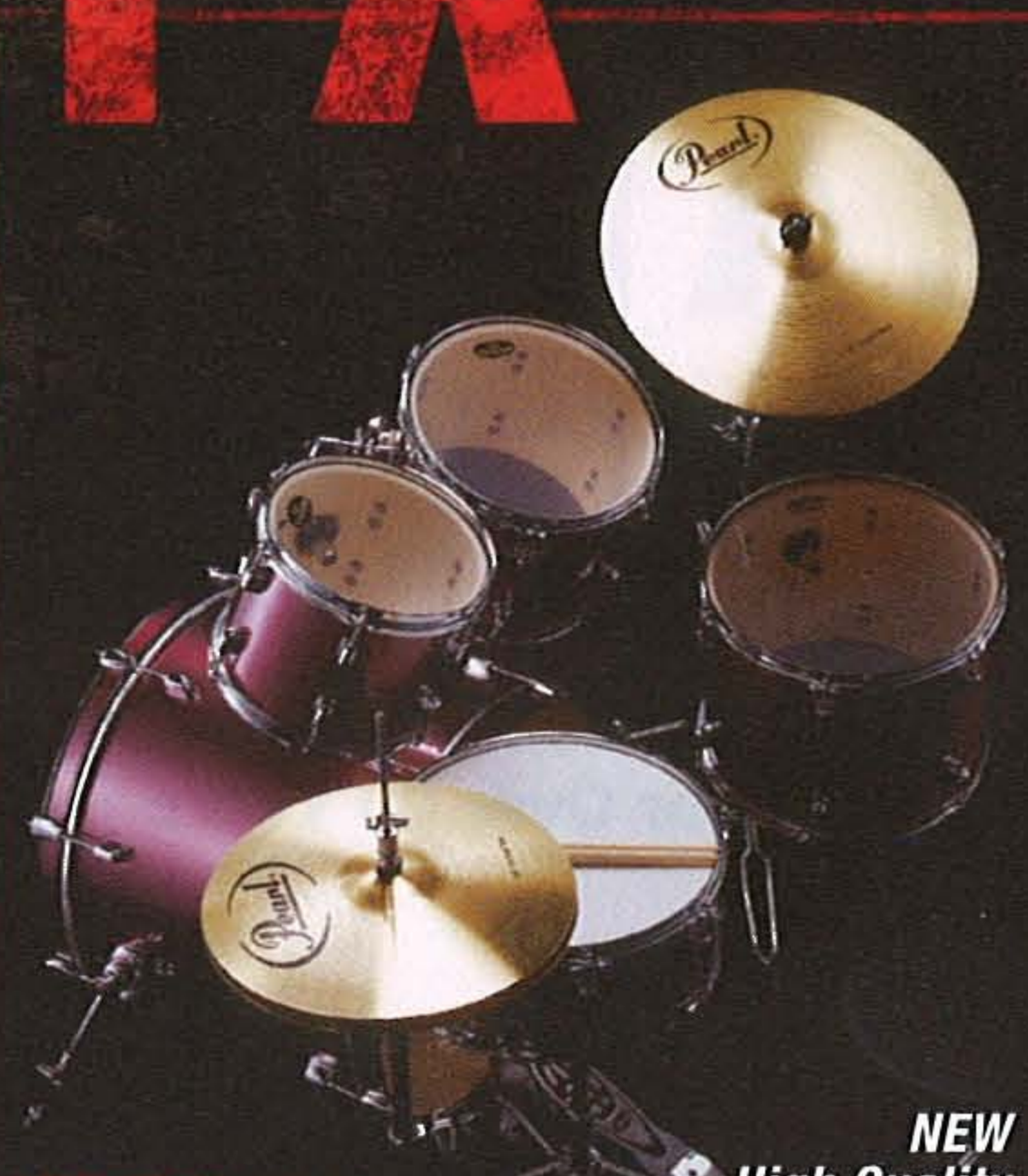

NEW
 High Quality
 Canadian Cymbals



NEW
 Carbon Black
 Finish



FX1455S

Forum Ready-Set-Go! is the all-in-one concept, that gets you started in style and ready to rock with the least amount of hassle. Forum has it all, plus the quality, the sound... that's genuine Pearl. With Forum Ready-Set-Go you get a complete five piece set of drums, a full set of rugged double braced hardware, a heavy-duty throne, high quality Canadian cymbals, a pair of Vic Firth drum sticks, and even a free DVD with all the set-up, tuning, and instructional pointers you'll need. Wow! Nobody offers a deal like this.

Forum also features a deep sized bass drum and extremely durable covered finishes in eight colour choices including the exciting New Carbon Black and Carbon Red. Included is a matching all wood Snare Drum, tough black carbon steel Bass Drum Hoops, dependable deep gear designed Tom Holders and one of Pearl's highly acclaimed, super fast Bass Drum Pedals. A vast array of optional component drums are available so you can add to your set as your needs change.

FORUM FX	FX725HSC	FX725SC	FX705SC
Bass Drum	2218B 22"x18"	2218B 22"x18"	2016B 20"x16"
Tom Tom	1008T 10"x 8"	1209T 12"x 9"	1008T 10"x 8"
Tom Tom	1209T 12"x 9"	1310T 13"x 10"	1209T 12"x 9"
Tom Tom	1412T 14"x12"	1616F 16"x16"	1414F 14"x14"
Snare Drum	1455S 14"x5.5"	1455S 14"x5.5"	1455S 14"x5.5"
Crash-Ride Cymbal	PC-318CR 18"	PC-318CR 18"	PC-318CR 18"
Hi-Hat Cymbals	PC-314HH 14"(1pr.)	PC-314HH 14"(1pr.)	PC-314HH 14"(1pr.)
Tom Holder	TH-70 (x2)	TH-70 (x2)	TH-70 (x2)
Tom Holder, Short	TH-70S	----	----
Adapter	AX-20	----	----
Hi-Hat Stand	H-72W	H-72W	H-72W
Snare Drum Stand	S-70W	S-70W	S-70W
Cymbal Boom Stand	B-70W	B-70W	B-70W
Drum Pedal	P-120	P-120	P-120
Drum Throne	D-70W	D-70W	D-70W
Drumsticks	Vic Firth 5A	Vic Firth 5A	Vic Firth 5A
DVD	An Introduction to Drumming featuring ERIC SINGER		

Masters
 Session
 SensiTone
 UltraCast
 FireCracker
 Effect
 Free Floating System
 Signature Models

The most comprehensive inventory of Snare Drums is available from your percussion leader, Pearl.

Nothing affects the sound of your kit like your snare.

Wood, Steel, Brass, Copper, or Aluminum, they're all here. Consider this your personal library of sound.

Check one out today.

Pearl Snare Drums



FX725SC
 #44 Carbon Black

FX725HSC
 #45 Carbon Red

FX725HSC
 #21 Smokey Chrome

Exclusive Covered Finish

#21 Smokey Chrome	
#31 Jet Black	#33 Pure White
#44 Carbon Black	#45 Carbon Red
#91 Red Wine	#95 Deep Blue
	#98 Charcoal Metallic

Ultra-Sound Snare Wires

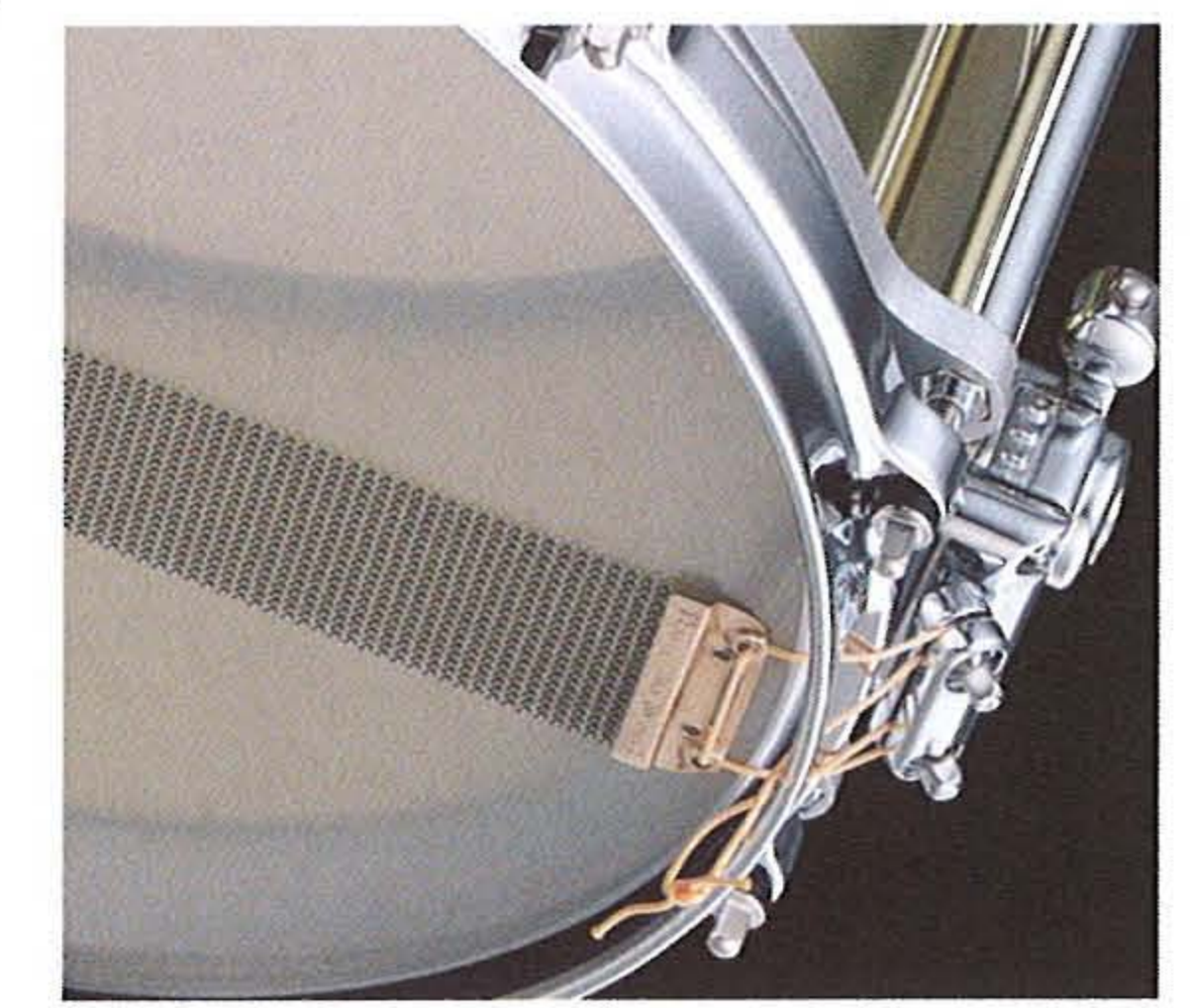
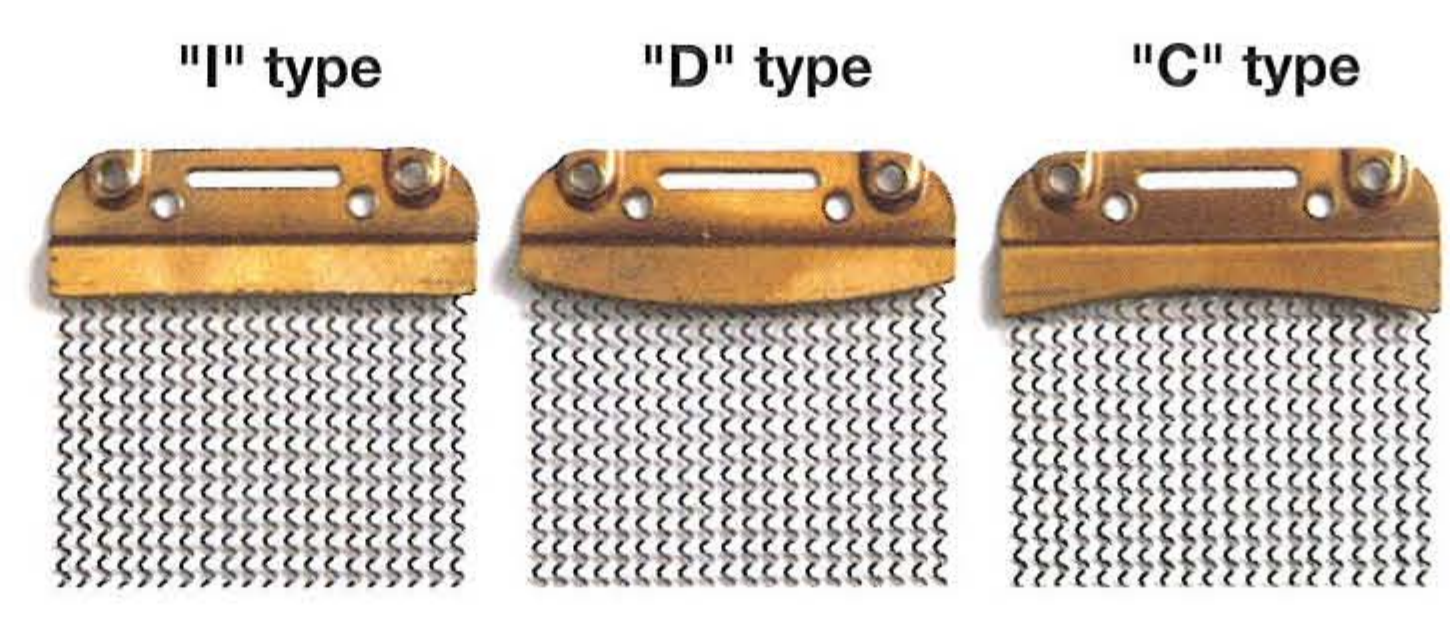

Pearl's new Ultra-Sound snares set a new standard and feature patent pending Graduated Tension snares on the "C" and "D" type snares, for extended dynamic range from ultra soft to ultra loud. The SN-1420C has "C" shaped end plates with looser tension wires in the centre for outstanding tracking and response and is ideal for rock music and metal snare drums. The SN-1420D has "D" shaped end plates with tighter tension wires in the centre for superb sensitivity and is ideal for classical music and wood snare drums. Finally the SN-1420I has even tension snare wires for those who want traditional snare dynamics but with the benefits of the Ultra-Sound's ultra quick snare wires.

All Ultra-Sound snares use non-plated rust proof snare wires and ultra-thin, low mass and 0.6mm Phosphor Bronze end plates for ultra quick response. Additionally, the end plates have three mounting options: Tunnels or holes for cord mounting and slots for straps.

New SR-1000 Glide-Lock Strainer

Pearl's new SR-1000 Glide-Lock strainer (Pat.Pend) addresses two age-old strainer problems that have plagued drummers for years: the throw-off lever flipping off and the tension knob loosening while playing. The SR-1000's throw-off lever features a Positive Lock system that locks in the ON position and completely removes the possibility of the snares turning off no matter how hard you play. Using low-friction technology the lever has a smooth gliding action to raise and lower the snares with ultra quiet precision. The tension knob also locks and both the throw-off and butt plate can be removed from the shell with the snares attached to allow quick and easy bottom head changes.

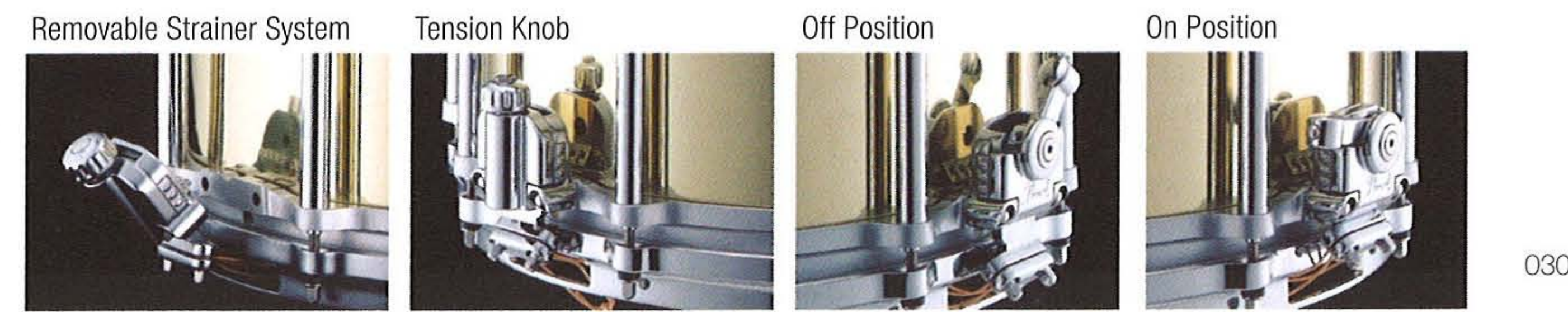

All New *Let your Rhythm Run*
Rhythm Traveler

Easy to transport and easy to practice, the ground breaking concept kit Rhythm Traveler now comes with newly designed lug, spur, and hardware. This complete 5pc kit includes professional quality 2 ply "Protone" heads and 13" and 16" cymbals for your live performance, and silent mesh heads and plastic cymbals are also provided for your near - silent practicing.



Plastic Heads & Real Cymbals
 for Live Playing



Muffle Heads (mesh) & Cymbal Muffers
 for Practicing

Rhythm Traveler	RT705HC
20"x 8" Bass Drum, 10"x 5" / 12"x 5" / 14"x 5" Tom Tom, 13"x 5" Wood Snare Drum, Mesh Heads, Protone Heads, Cymbals : CX216 / 16" Crash Ride, CX213 / 13" Hi-Hat (x2), Cymbal Pads : RP-CP (x2) for Ride and Hi-Hat Cymbals, Plastic Cymbals : RP-13PRC (for Ride), RP-13PHH (for Hi-Hat), TH-60 (x2) Tom Holder, TH-60S Tom Holder, ADT-2 Adapter, C-62W Cymbal Stand, P-62 Drum Pedal, H-62W Hi-Hat Stand, S-62W Snare Stand	
Available Finishes : #31 Jet Black, #33 Pure White	



Masters

Nothing highlights your overall finesse like your snare drum.
Masters Series snares are the ultimate compliment for your drumset.
A perfect match sonically and visually for your Masters kit or a dynamic upgrade for any drumset. All Masters Series snare drums feature our die-cast hoops, stainless steel tension rods and that unmistakable Masters Sound.

* w/4 ply Maple glue rings

6 ply Maple



MRX1465S

Size (Dia. x Depth)	14" x 6.5"
Shell	6 ply Maple
Hoops	Master Cast (DC1410/DC1410S)
Lugs	CL-65
Rods	10
Tension Rods	SST-5047
Strainer	SR-015
Snares	S-022N



MRX1455S

Size (Dia. x Depth)	14" x 5.5"
Shell	6 ply Maple
Hoops	Master Cast (DC1410/DC1410S)
Lugs	CL-55
Rods	10
Tension Rods	SST-5052
Strainer	SR-015
Snares	S-022N

4 ply Maple



MMX1465SD

Size (Dia. x Depth)	14" x 6.5"
Shell	4 ply Maple*
Hoops	Master Cast (DC1410/DC1410SG)
Lugs	CL-100
Rods	10
Tension Rods	SST-5047
Strainer	SR-015
Snares	S-030N



MMX1465S

Size (Dia. x Depth)	14" x 6.5"
Shell	4 ply Maple*
Hoops	Master Cast (DC1410/DC1410S)
Lugs	CL-65
Rods	10
Tension Rods	SST-5047
Strainer	SR-015
Snares	S-022N



MMX1455S

Size (Dia. x Depth)	14" x 5.5"
Shell	4 ply Maple*
Hoops	Master Cast (DC1410/DC1410S)
Lugs	CL-55
Rods	10
Tension Rods	SST-5052
Strainer	SR-015
Snares	S-022N

6 ply Maple



MSX1465S

Size (Dia. x Depth)	14" x 6.5"
Shell	6 ply Maple
Hoops	Master Cast (DC1410/DC1410S)
Lugs	CL-65
Rods	10
Tension Rods	SST-5047
Strainer	SR-015
Snares	S-022N



MSX1455S

Size (Dia. x Depth)	14" x 5.5"
Shell	6 ply Maple
Hoops	Master Cast (DC1410/DC1410S)
Lugs	CL-55
Rods	10
Tension Rods	SST-5052
Strainer	SR-015
Snares	S-022N

4 ply African Mahogany



MHX1465S

Size (Dia. x Depth)	14" x 6.5"
Shell	4 ply African Mahogany*
Hoops	Master Cast (DC1410/DC1410S)
Lugs	CL-65
Rods	10
Tension Rods	SST-5047
Strainer	SR-017
Snares	S-022N



MHX1455S

Size (Dia. x Depth)	14" x 5.5"
Shell	4 ply African Mahogany*
Hoops	Master Cast (DC1410/DC1410S)
Lugs	CL-55
Rods	10
Tension Rods	SST-5052
Strainer	SR-017
Snares	S-022N

6 ply Birch



BRX1465S

Size (Dia. x Depth)	14" x 6.5"
Shell	6 ply Birch
Hoops	Master Cast (DC1410/DC1410S)
Lugs	CL-65
Rods	10
Tension Rods	SST-5047
Strainer	SR-017
Snares	S-022N



BRX1455S

Size (Dia. x Depth)	14" x 5.5"
Shell	6 ply Birch
Hoops	Master Cast (DC1410/DC1410S)
Lugs	CL-55
Rods	10
Tension Rods	SST-5052
Strainer	SR-017
Snares	S-022N

Session Series Snare Drums



SMX1455S

Size (Dia. x Depth)	14" x 5.5"
Shell	6 ply Birch
Hoops	SuperHoop II (SH1408B/SH1408S)
Lugs	NCL-55
Rods	8
Tension Rods	T-061L
Strainer	SR-017
Snares	S-022N



SBX1455S

Size (Dia. x Depth)	14" x 5.5"
Shell	6 ply Birch
Hoops	SuperHoop II (SH1408B/SH1408S)
Lugs	NCL-55
Rods	8
Tension Rods	T-061L
Strainer	SR-017
Snares	S-022N

SensiTone

SensiTone Snare Drums are recognized the world over. Like some of the other highly sought after vintage drums of yester-year, these drums are destined to take their place in history. Available in Steel or Brass and 8 different sizes, they all feature beaded metal shells that articulate every subtle note that you play. To make every nuance heard, there is only one SensiTone.



UltraCast

UltraCast has turned into a modern gothic novel. An experiment gone awry. A monster in the truest sense. We set out to make a precision milled cast Aluminum shell that would project energy and be heard over the chaos of a live band. UltraCast has done that beyond our wildest dreams. When you hear players like Morgan Rose, Mike Wengren or Joey Jordison, you're hearing the power of UltraCast. Available in 2 sizes, only one attitude.

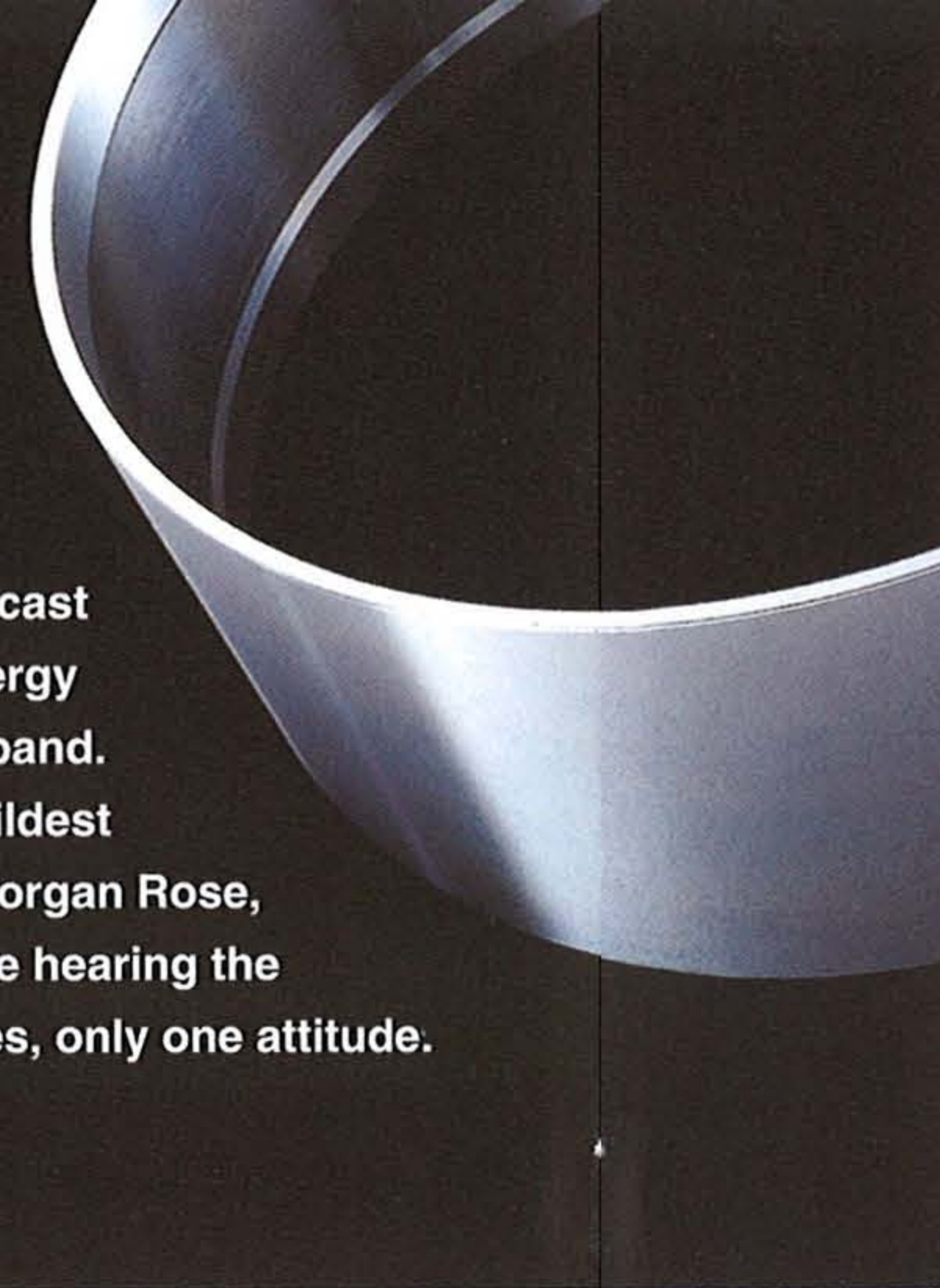

SR-1000
Glide-Lock Strainer

	UCA1465 / B	UCA1450 / B
Size (Dia. x Depth)	14" x 6.5"	14" x 5"
Shell	3mm Cast Aluminum	3mm Cast Aluminum
Hoops	SuperHoop II (SHB1410B/1410S)	SuperHoop II (SHB1410B/1410S)
Lugs	TB-65B	TB-50B
Rods	10	10
Tension Rods	SST-5042	SST-5042
Strainer	SR-1000	SR-1000
Snares	SN-1420C Ultra-Sound "C" Type	SN-1420C Ultra-Sound "C" Type

SensiTone Classic II



	SCB1450B	SCS1450	STB1465	STB1455	STS1465	STS1455
Size (Dia. x Depth)	14" x 5"	14" x 5"	14" x 6.5"	14" x 5.5"	14" x 6.5"	14" x 5.5"
Shell	Beaded Brass, Black Nickel Plated	Beaded Steel	Beaded Brass	Beaded Brass	Beaded Steel	Beaded Steel
Hoops	Master Cast (DC1410/DC1410S)	SuperHoop II (SH1410B/1410S)	SuperHoop II (SH1410B/1410S)	SuperHoop II (SH1410B/1410S)	SuperHoop II (SH1410B/1410S)	SuperHoop II (SH1410B/1410S)
Lugs	TB-50	TB-50	CL-65	CL-55	CL-65	CL-55
Rods	10	10	10	10	10	10
Tension Rods	SST-5042	SST-5042	SST-5047	SST-5052	T-061L	T-062
Strainer	SR-017	SR-017	SR-017	SR-017	SR-017	SR-017
Snares	S-022N	S-022N	S-022N	S-022N	S-022N	S-022N

FireCracker

When you are ready to add some new chops, the first thing to do is to add a secondary snare. There is no doubt as to how these powerhouses got their name. Available in 12" x 5" and 10" x 5" sizes in a choice of 8 ply Poplar or Steel. Light fuse and get away.

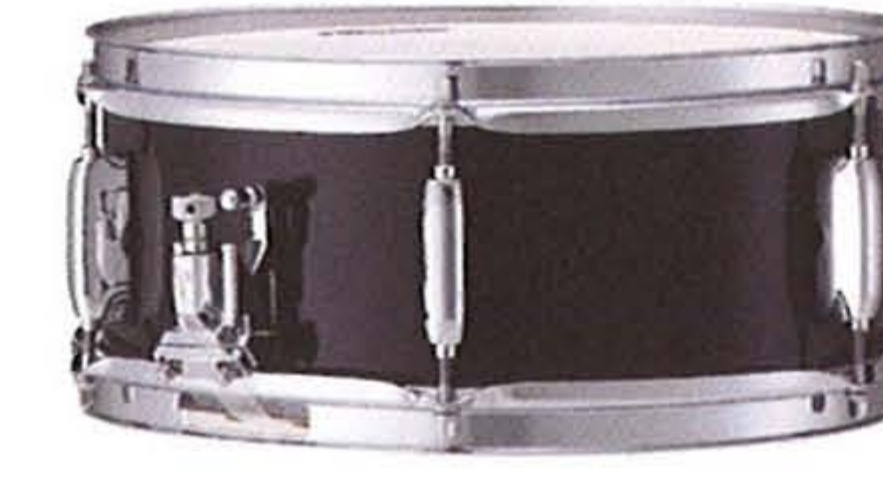

Standard Steel



	FCS1050	FCS1250	FCP1050	FCP1250	SS1455
Size (Dia. x Depth)	10" x 5"	12" x 5"	10" x 5"	12" x 5"	14" x 5.5"
Shell	1.0mm Steel	1.0mm Steel	8ply Poplar	8ply Poplar	Steel
Hoops	1.6mm Steel (RIM1060/1060S)	1.6mm Steel (RIM1206/1206S)	1.6mm Steel (RIM1060/1060S)	1.6mm Steel (RIM1206/1206S)	1.6mm Steel (RIM1408B/1408S)
Lugs	CL-50	CL-50	CL-50	CL-50	CL-50
Rods	6	6	6	6	8
Tension Rods	T-061L	T-061L	T-061L	T-061L	T-062
Strainer	SR-018	SR-018	SR-018	SR-018	SR-014N
Snares	S-032	S-031	S-032	S-031	S-022

Effect

These highly specialized drums allow you to accent your sound to be as unique as you are. Available in a range of sizes to add character and a new dynamic range to your set.



	M1040 Soprano	M1060 Popcorn	M1270 Soprano	B1330 Piccolo	S1330B Piccolo	M1330 Piccolo	M1440 Piccolo
Size (Dia. x Depth)	10" x 4"	10" x 6"	12" x 7"	13" x 3"	13" x 3"	13" x 3"	14" x 4"
Shell	6 ply Maple	6 ply Maple	8 ply Maple	Brass	Steel	6 ply Maple	6 ply Maple
Hoops	1.6mm Steel (RIM1006/1006SL) w/l.S.S.	SuperHoop II (SH1006/1006S)	1.6mm Steel (RIM1208B/1208S)	1.6mm Steel (RIM1308B/1308S)	1.6mm Steel (RIM1308B/1308S)	1.6mm Steel (RIM1308B/1308S)	1.6mm Steel (RIM1410B/1410S)
Lugs	CL-05	CL-65	CL-100	CL-05	CL-05	CL-05	CL-05
Rods	6	6	8	8	8	8	10
Tension Rods	SST-5038	SST-5038	SST-5047	T-055	T-055	T-055	SST-5042
Strainer	SR-018	SR-018	SR-018	SR-018	SR-018	SR-018	SR-018
Snares	S-032N	S-032N	S-031N	S-029N	S-029N	S-029N	S-022N

SR-1000
Glide-Lock Strainer

Free Floating System

Free Floating Snares offer the truest articulation and response from the shell material. The shell is completely isolated from any hardware, nothing to encumber its ringing clarity, just unbridled response. Pearl's Free Floating System is available in several sizes and 4 different shell materials, Brass, Copper, Steel or 6 ply premium Maple. The only way to experience the Free Floater is at your Pearl Dealer.

Shell	6 ply Maple	Brass	Copper
Size (Dia. x Depth) 14" x 6.5" Hoops Master Cast (DC1410/DC1410S) Lugs FT-65 Rods 10 Tension Rods SST-5042 (NEW) Strainer SR-1000 (NEW) Snares SN-1420I Ultra-Sound™ I" Type			
	FM1465 / C	FB1465 / C	FC1465 / C
Size (Dia. x Depth) 14" x 5" Hoops Master Cast (DC1410/DC1410S) Lugs FT-50 Rods 10 Tension Rods SST-5042 (NEW) Strainer SR-1000 (NEW) Snares SN-1420I Ultra-Sound™ I" Type			
	FM1450 / C	FB1450 / C	FC1450 / C
Size (Dia. x Depth) 14" x 3.5" Hoops Master Cast (DC1410/DC1410S) Lugs FT-35 Rods 10 Tension Rods SST-5038 (NEW) Strainer SR-1000 (NEW) Snares SN-1420I Ultra-Sound™ I" Type			
	FM1435 / C	FB1435 / C	FC1435 / C

Shell	Steel
Size (Dia. x Depth) 14" x 3.5" Hoops 1.6mm Steel (RIM1410B/1410S) Lugs FT-35 Rods 10 Tension Rods T-060 (NEW) Strainer SR-1000 (NEW) Snares SN-1420I Ultra-Sound™ I" Type	
	FS1435B / C

Signature Series

Imagine being able to capture that elusive sound of your drumming idol. Pearl's extensive line of Signature Series Snares gives you an opportunity to own a snare developed with input from the pros. We offer snares from some of the world's greatest players, and they're all available at your Pearl Dealer.

	Joey Jordison Joey Jordison has a reputation as one of the most influential, respected and successful drummers in the world today. Playing stadiums worldwide with Slipknot, Joey needed a snare drum with a higher pitch with monster bite and this 13" x 6.5" 1mm Steel shell Power Piccolo delivers the rage and power you'd expect from Joey.	
	Virgil Donati Virgil has pushed back the barriers of playing drums with an innovative use of the instrument, complex rhythms, creative phrasing and extreme speed and naturally he has taken great care to design a unique snare drum. Using a 8 ply blended shell, rounded bearing edges and a totally flat snare bed, Virgil's signature snare drum is a State-of-the-art as his playing.	
	Ian Paice Deep Purple's legendary drummer designed this snare drum to have classic looks, classic sound but with a modern specification. The 6.5" steel shell will give you big rock sound and the locking nuts will help your drum to "stay tuned all night".	
	Tico Torres After decades of international success with Bon Jovi, Tico Torres worked with the Pearl design team and chose a cast aluminium shell to achieve a sound that has the warmth of a wood drum yet still has the bite of a metal drum.	

	JJ1365 Size (Dia. x Depth) : 13" x 6.5" Shell : Steel/Black Finish Hoops : SuperHoop II / Black Finish SHB1308B / 1308S Lugs : CL-65B Rods : 8 Tension Rods : SST-5047 Strainer : SR-17B Snares : S-029N
	VG1450 Size (Dia. x Depth) : 14" x 5" Shell : 8ply (Outer: 4ply Maple / Inner : 4ply Birch) Hoops : Master Cast (DC1410/DC1410S) Lugs : TB-50 Rods : 10 Tension Rods : SST-5042 Strainer : SR-017 Snares : S-022N
	IP1465 Size (Dia. x Depth) : 14" x 6.5" Shell : Beaded Steel Hoops : SuperHoop II (SH1410B/1410S) Lugs : TB-65 Rods : 10 Tension Rods : SST-5042 Strainer : SR-017 Snares : S-022N
	TR1465 Size (Dia. x Depth) : 14" x 6.5" Shell : 3mm Cast Aluminum Hoops : Master Cast (DCS1410B/DCS1410SG) Lugs : FT-65S Rods : 10 Tension Rods : SST-5042 Strainer : SR-010 Snares : S-025

	Eric Singer Eric has excelled in the most extreme musical situations and played for Kiss as well as Alice Cooper. His signature snare drum is designed to give you more projection and depth using our thickest drum shell (10 plies of aged 100% maple) and it has a unique penetrating sound.	
	Dennis Chambers As one of the world's most respected international session musicians and clinician, Dennis's signature snare drum has outstanding sound and tonal dynamics. This top specification drum includes a wide range of features to help you achieve the perfect sound.	
	Omar Hakim Having played the drums for Sting, Madonna and David Bowie, to name but a few, Omar was looking for a unique sound in designing his signature snare drum. The 13 x 5 shell has a power piccolo sound while the Mahogany helps to produce the perfect blend of sonic power, projection and tonal colour.	
	Chad Smith Loud, Loud and louder... What else would expect Chad Smith to sound like in the Red Hot Chili Peppers. This awesome rock drum looks as good as it sounds and produces consistently, one of the best, overall rock drum sounds in the world today.	
	Steve Ferrone Tasteful musicality and powerful groove...the trademarks of Steve's sound...that why he's the first call for superstars such as Eric Clapton and Tom Petty. His signature snare drum is a reflection of the maestro's playing style, tasteful and elegant, yet powerful on demand.	

	ES1465 Size (Dia. x Depth) : 14" x 6.5" Shell : 10 ply Maple Hoops : Die Cast (DC1410/DC1410S) Lugs : CL-65 Rods : 10 Tension Rods : SST-5047 Strainer : SR-017 Snares : S-022N Color : #160 Silver Sparkle
	DC1465 Size (Dia. x Depth) : 14" x 6.5" Shell : 4 ply Maple w/4 ply Maple glue rings Hoops : Die Cast (DC1410/DC1410SG) Lugs : CL-100 Rods : 10 Tension Rods : SST-5047 Strainer : SR-020 x 2 Snares : S-030N Head : Evans B-14GIRB /S-14H30 Color : #136 Opal White
	OH1350 Size (Dia. x Depth) : 13" x 5" Shell : 6 ply African Mahogany Hoops : SuperHoop II (SH1308B/1308S) Lugs : CL-55 Rods : 8 Tension Rods : SST-5047 Strainer : SR-015 Snares : S-029N Color : #140 Natural Mahogany
	CS1450 Size (Dia. x Depth) : 14" x 5" Shell : Beaded Brass,Black Nickel Plated Hoops : SuperHoop II (SH1410B/1410S) Lugs : CL-55 Rods : 10 Tension Rods : SST-5047 Strainer : SR-015 Snares : S-022
	SF1465 Size (Dia. x Depth) : 14" x 6.5" Shell : Beaded Brass,Black Nickel Plated Hoops : SuperHoop II (SHG1410B/SHG1410S) Lugs : Tube (TB-65 CG) Rods : 10 Tension Rods : SST-5042 Strainer : SR-017CG Snares : S-022N

PEARL ADVANCED HARDWARE SYSTEMS



PEARL HARDWARE, THE CHOICE OF PROFESSIONALS

Pearl's Advanced Hardware Systems introduces a line of professional grade hardware that will forever alter the way that you look at hardware. Hardware strengthened with innovations like our double strut legs to prevent lateral movement, hidden nylon bushings within the tubes to prevent metal to metal contact and the inherent squeaks that arise from it. Oversized non-slip rubber feet provide greater surface adhesion to keep everything firmly planted. Our new die cast pipe joints provide super human clamping power via our UltraGrip wingnuts to keep everything exactly where you want it. This new hardware will introduce mounting options never before attainable. Each piece is engineered to function above and beyond traditional hardware. That's why we call it advanced.

**ADVANCED
HARDWARE SYSTEMS**

PEARL DRUM PEDALS

PowerShifter
ELIMINATOR

INTERCHANGEABLE CAM SYSTEM US.PAT.6172291

Our exclusive Cam System provides six (included 4 + optional 2) interchangeable color coded cams allowing you to quickly change the power and feel of the pedal to suit your individual playing needs. Changing from cam to cam is as simple as pushing the release button and snapping another cam in place.

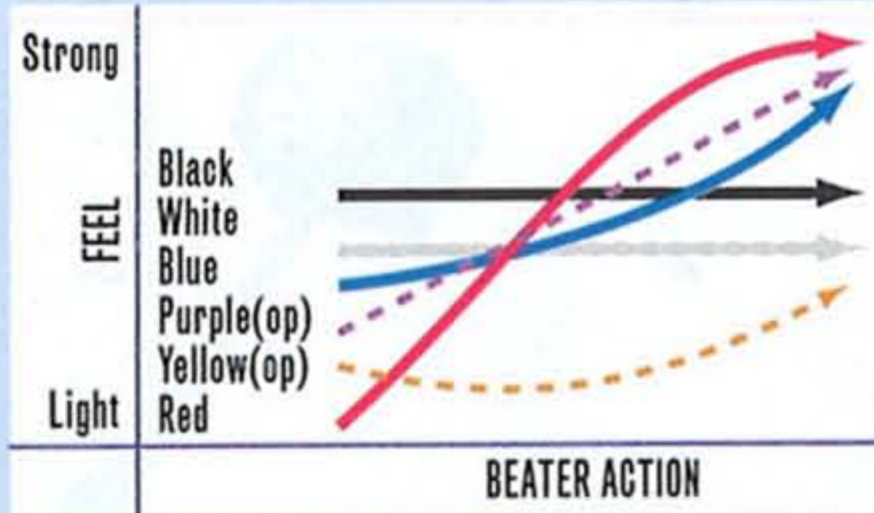

BLACK LINEAR ACTION CAM



This is Pearl's original "perfect circle" Cam design. It offers superior power and a very natural, perfectly balanced action and smooth feel.

WHITE OVERSIZED LINEAR CAM



The White Cam is a slightly over sized "perfect circle" Cam. It offers a very natural, smooth action, with great power and balance, with a slightly lighter pedal feel.

BLUE PROGRESSIVE CAM



This is the very popular "off-center" axis type cam design. It offers a lighter feel in the beginning that accelerates with speed and power upon impact.

RED RADICAL PROGRESSIVE CAM



The Red Cam features an extreme "off-center" axis design. It provides traditional action with great response to sensitive footwork and extreme power upon impact.

OPTION CAMS

PURPLE CAM-PL

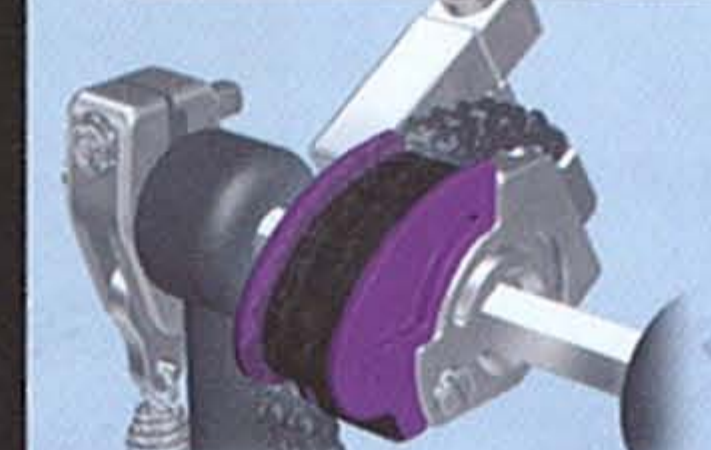

The new Purple cam provides aggressive acceleration for huge power and response, second only to the Red cam.

YELLOW CAM-YL



The new Yellow cam provides a slight inverse action with response being smooth and predictable slightly under the White cam.

Pearl's PowerShifter Eliminator provides the ultimate in player tunability and control. With a choice of 6 different cams (included 4 + optional 2), 4 beater faces, PowerShifter functionality, and complete control over pedal surface grip or slip, this is the most tuner friendly pedal that you can buy.

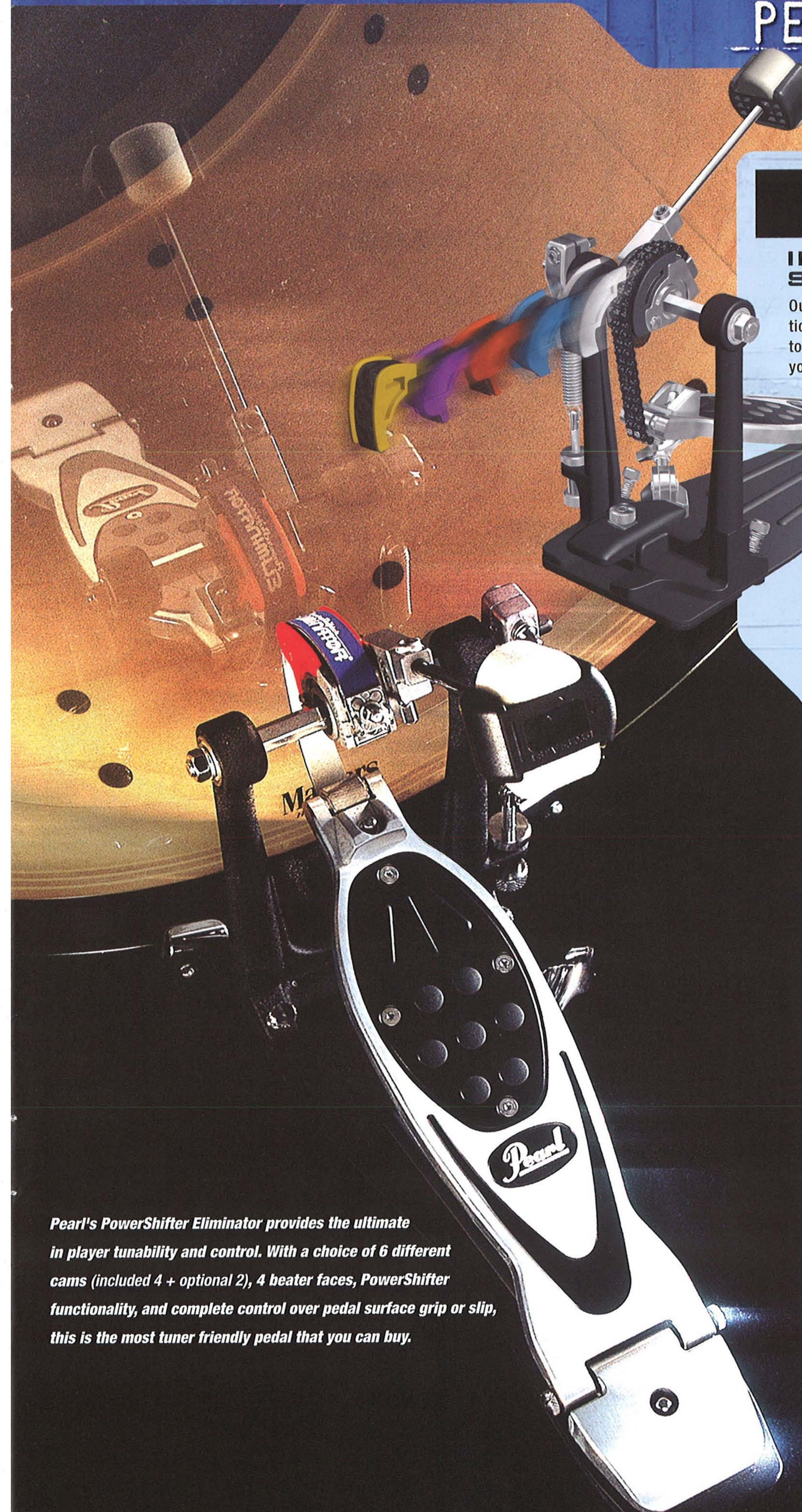

PEARL DRUM PEDALS

CHAIN DRIVE

Pearl's double chain drive glides silently within the cam channel providing a super smooth, quiet, powerful precision feel. Since there are no sprockets involved, there is much less wear on the chain and less noise in the studio.

POWERSHIFTER
ELIMINATOR
DRUM PEDALS
**P-2000
SERIES**

P-2000C



BELT DRIVE

Our Belt Drive provides a very comfortable, natural feel similar to a direct drive system. We use an extremely strong, highly durable drive belt, instead of a normal rubber strap, to provide maximum durability, strength, and stretch resistance.

P-2000B



POWERSHIFTER

US.PAT.5574237
Our revolutionary PowerShifter function provides 3 positions to fine tune the power and feel of the pedal. By moving the footboard forward or back you change the chain or belt drive angle, thus changing the leverage to create a light, normal or strong feel.

LIGHT
NORMAL
STRONG



INDEPENDENT TRACTION GRIPS
Power Shifter Eliminator's Traction Plate footboard insert allows you to remove and reconfigure each individual traction grip to suit your exact playing requirements. From maximum grip to full slide, and every option in between, the choice is yours. The Traction Plate also reverses to focus the slide or grip surfaces to either the toe or heel of the pedal.

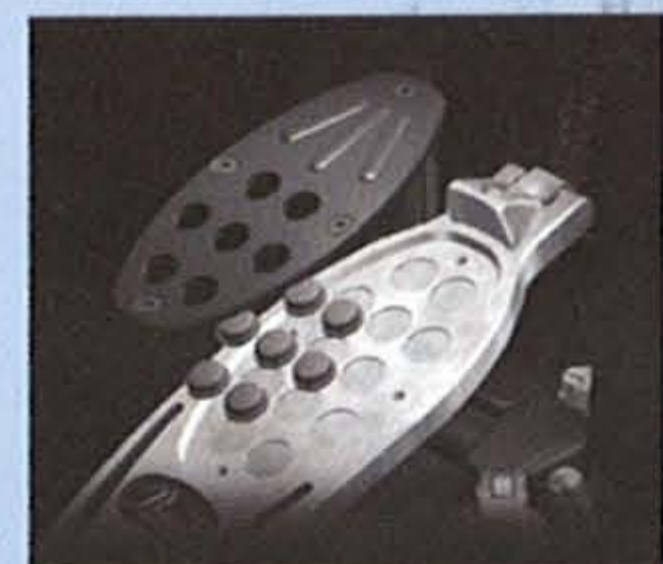

FOOTBOARD DESIGN
Our exclusive Footboard design offers perfect balance, great stability and extreme player comfort. By redesigning every aspect of the footboard, including spring tension, beater weight and pedal shape, we have created the most powerful feeling Bass Drum Pedal available. (PAT.PEND.)

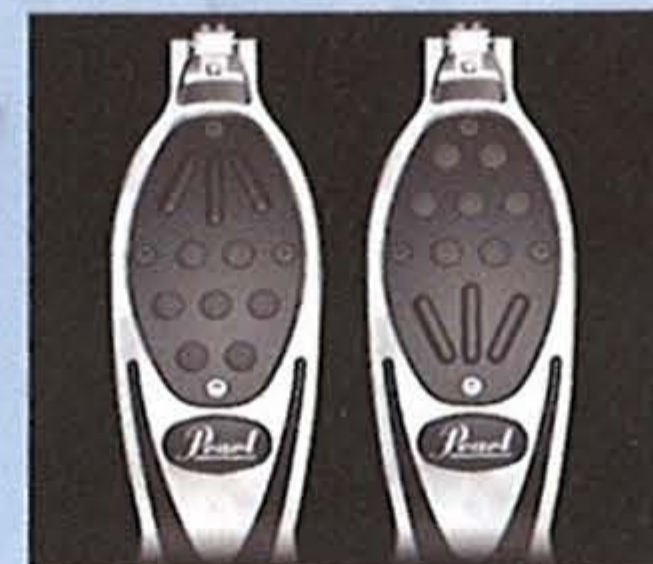

FOOTBOARD ANGLE ADJUSTMENT
Footboard angle is easily adjusted completely independent from beater angle allowing you to further fine tune the feel and action of your pedal.

ROLLER CAM HOOP CLAMP
Our Roller Cam Hoop Clamp multiplies each turn of the adjustment knob to speed the process of attaching the pedal to the hoop. It fits an extremely wide range of hoop thicknesses and offers the smoothest, most secure grip possible. (US.PAT.5726370)

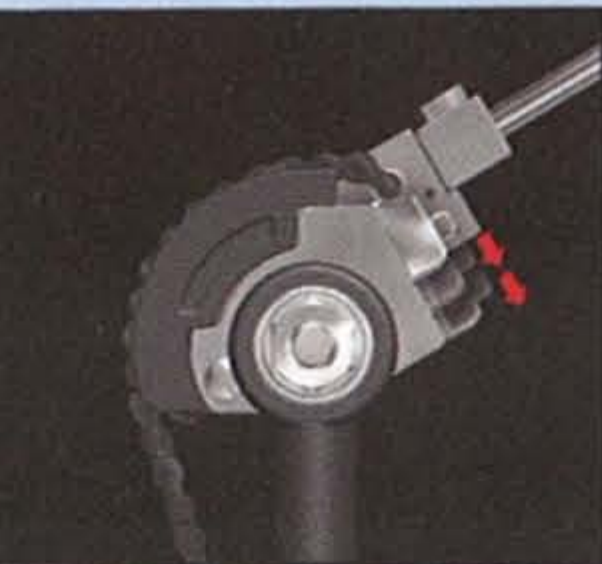

WIDE TENSION-RANGE SPRING
Our counter spring has been designed to perfectly compliment the weight and balance of the footboard and beater assembly. It also offers a much wider range of adjustability allowing you to fine tune the pedal tension to suit your playing style.

UNI-PRESSURE SPRING CLAMP
Our Uni-Pressure Spring Clamp System grips a full 360 degrees and allows infinite beater angle adjustments. Featuring a unique Floating Spring Pendulum design that is perfectly centered on the clamp, this system offers full precision bearing movement for unmatched smoothness.

**DOUBLE PEDALS
P-2002C**

DOUBLE PEDALS
SLAVE CONVERSION
P-2001C

DOUBLE PEDALS
(LEFT-FOOTED)
P-2002CL



**DOUBLE PEDALS
P-2002B**

DOUBLE PEDALS
SLAVE CONVERSION
P-2001B

DOUBLE PEDALS
(LEFT-FOOTED)
P-2002BL



POWERSHIFTER
DRUM PEDALS
**P-1000
SERIES**

P-1000



**DOUBLE PEDALS
P-1002**

DOUBLE PEDALS
SLAVE CONVERSION
P-1001

DOUBLE PEDALS
(LEFT-FOOTED)
P-1002L



DRUM PEDALS
**P-120
SERIES**

P-120P



P-120



**DOUBLE PEDALS
P-122TW**



CHAIN & BELT DRIVE

The P-1000 offers a choice of Belt or Chain drive. You decide because they're both included. It features a round linear cam, Bold Eliminator Styling, Power-Shifter functionality and UltraGrip wingnuts. The perfect upgrade to improve your Bass Drum finesse.

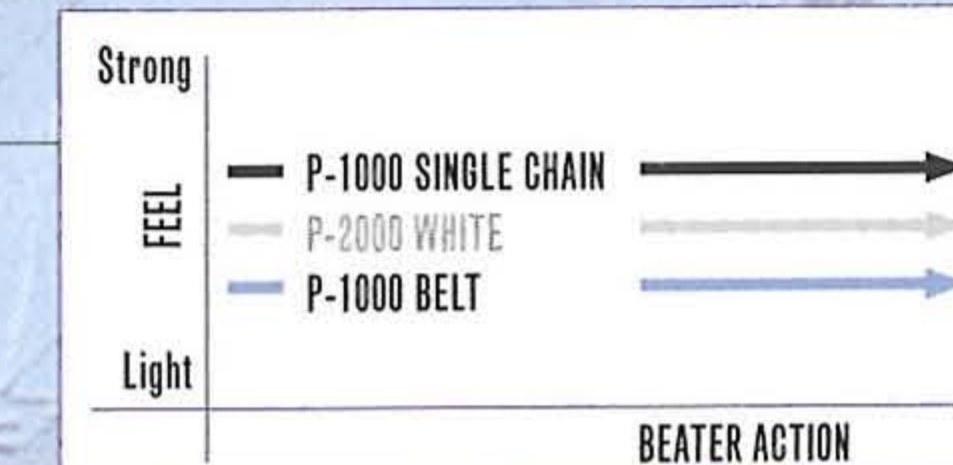

QUADBEATER

Our QuadBeater provides four different beater surfaces, each with its own distinct sound. You can choose from 2 hard plastic surfaces or 2 felt surfaces and either pinpoint or line contact with the head.

DUOBEAT

The DuoBeat Beater offers two different faces, plastic and felt, adding great versatility of sound over single surface beaters. It's like getting two beaters for the price of one.

QUADBEATER (US.PAT.5610351)

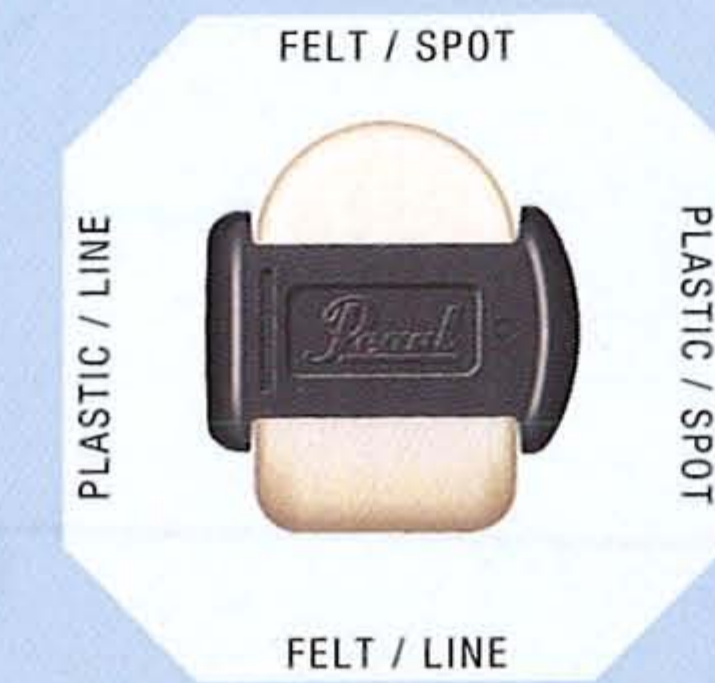

DUOBEAT



P-2000/1000 SERIES
now with Custom Carry bags



PEARL DRUM PEDALS

MODEL	POWERSHIFTER ELIMINATOR P-2000 SERIES				POWERSHIFTER P-1000 SERIES		P-120 SERIES		
	P-2000C	P-2002C	P-2000B	P-2002B	P-1000	P-1002	P-120P	P-122TW	P-120
DRIVE	Double Chain		Belt		Single Chain / Belt		Single Chain		
CAM	Interchangeable Cam				Aluminum Die-Cast/Plastic Wheel		Aluminum Die-Cast/Plastic Wheel		
POWERSHIFTER	•	•	•	•	•	•	•	•	---
FOOTBOARD	TractionPlate & TractionGrip				TractionPlate & TractionGrip				
FOOTBOARD ANGLE	3 Positions				3 Positions		---		
BEATER	QUAD BEATER				QUAD BEATER		DUO BEAT		
BEATER ANGLE	Uni-Lock Beater Angle Cam				Uni-Lock Beater Angle Cam		Beater Angle Cam		
SPRING ROLLER	Bearing				Bearing		FrictionLess Roller		
HOOP CLAMP	Roller Cam Hoop Clamp				Roller Cam Hoop Clamp		Roller Cam Hoop Clamp		

BEATER WEIGHT BW-100

The BW-100 Beater Weight features a main body (10.4 gram) and two removable add-on weights: Black (7.2 grams) and Silver (5.8 grams) that can be added or subtracted to achieve perfect feel and power. (PAT.PEND.)



PEDAL STABILIZER PS-85



HI-HAT STANDS

No other part of your kit takes the punishment that your Hi-hat takes. It has to be fast, responsive and strong to keep the groove moving. Pearl offers a wide range of Hi-hats to compliment your playing style. From our light-weight, easy to carry H-72W, to our studio Pro Eliminator, that like all Eliminators, it's fully adjustable via the exclusive interchagable cam system to become an extension of yourself.

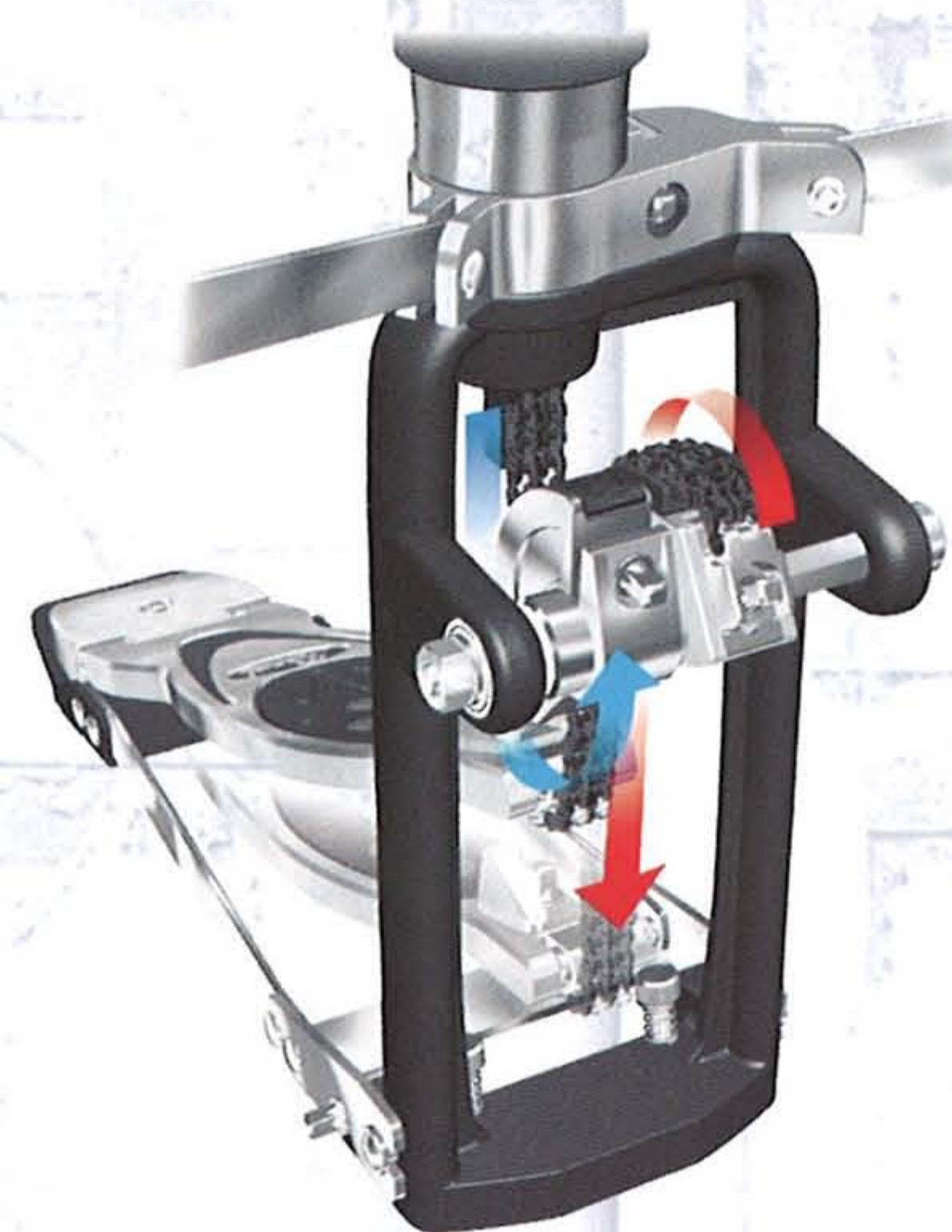

POSILINK TWIN CAM DRIVE SYSTEM w/ INTERCHANGEABLE CAMS (US.PAT.6399866)

Our exclusive PosiLink drive system features twin double chain driven cams one of which accepts your choice of 6 interchangeable cam profiles (4 included and 2 optional) so you can customize the response from mild to wild. If you want a traditional direct drive feel, use one of the two round cam profiles. But if you dare, try the four eccentric cam profiles with varying degrees of offset for accelerated feel that you can't get from any other hi-hat on the planet!

POWERSHIFTER

PowerShifter allows the player to quickly shift the footboard to 1 of 3 playing positions. This changes the angle of the pull chain which in turn changes the overall feel of the hi-hat reaction.

TRACTION PLATE FOOTBOARD

Like all Eliminators, the pedal has removable traction grip inserts that can be adjusted or removed to tailor the amount of grip or slip. The plate is even reversible for more choices.

VARISET FOOTBOARD ANGLE ADJUSTMENT

The VariSet cam is infinitely adjustable to allow micro-fine adjustment of the footboard angle for optimum comfort and speed. This can be further adjusted on the pedal cam side to compensate for the different heights produced by interchanging of the cams.

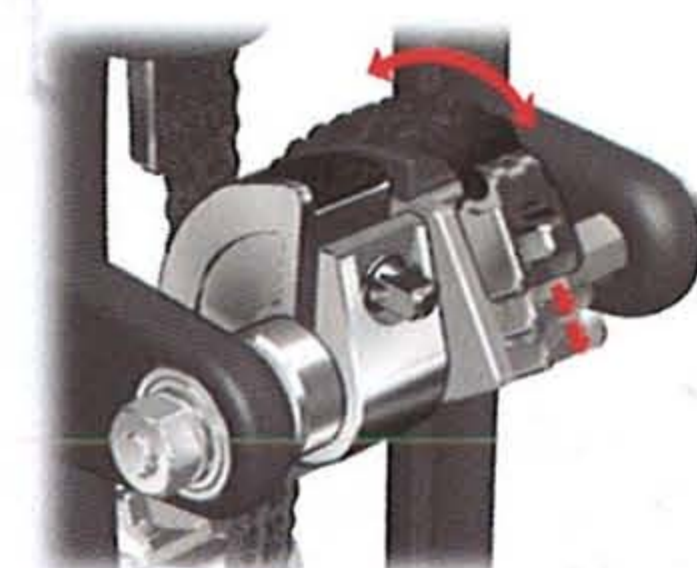

1. SUPERGRIP CLUTCH (SGC-300P) (PAT.PEND)

The H-2000 features our SuperGrip Clutch. This clutch system uses a larger surface area with 360° of grip that provides vice like clamping force for super grip.

2. STANDARD CLUTCH (CL-300)

Our CL-300 clutch used in both of our 1000 series Hi-hats provides solid predictable performance with zero slippage.

3. HI-HAT CUP (PAT.PEND)

Our new patent pending seat cup features a hinged platform for outstanding stability and consistent Hi-hat sound.

4. PRECISION SPRING TENSION DIAL

Our precision Spring Tension Dial features a positive click stop design for precise control over Hi-Hat tension.

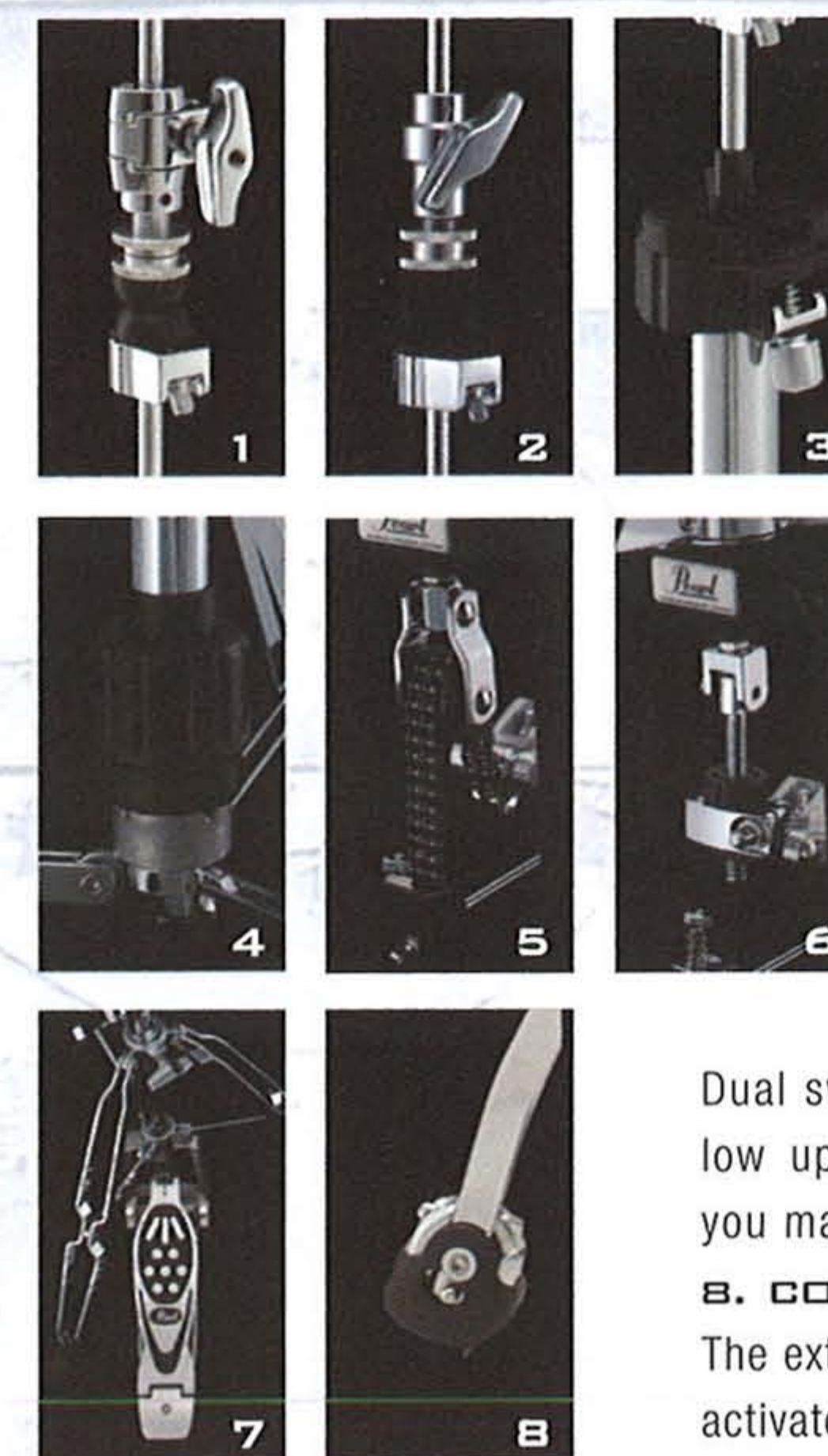

5. ROLLER PULLEY SYSTEM (US.PAT.5018426)

The roller system uses a pulley to provide incredible cymbal force with minimal pedal exertion.

6. FOOTBOARD ANGLE ADJUSTMENT

The H-1000's exclusive threaded foot board connector allows the footboard to be infinitely adjustable for maximum speed and comfort.

7. SWIVELING LEGS

Dual swiveling legs on our H-2000 and RH-2000 allow up close placement of these stands anywhere you may need them.

8. CONVERTIBLE SPIKE / RUBBER TIPS

The extra large non-slip rubber feet have a push button activated spike that pops out for non-slip grip on carpet or rubber surface. A second button returns it instantly to its recessed position. (PAT.PEND)

HI-HAT ACCESSORIES

[NEW]

CLOSED HAT CLH-1000

Our Closed Hi-hat accessory facilitates the placement of a hi-hat anywhere. It includes a boom arm, new Uni-Lock tilter, improved seat cup and our UltrGrip wingnuts.



HI-HAT ATTACHMENT HA-100

The HA-100 positions your Hi-Hat next to your bass pedal in double bass set-ups for super quick transitions between pedals.

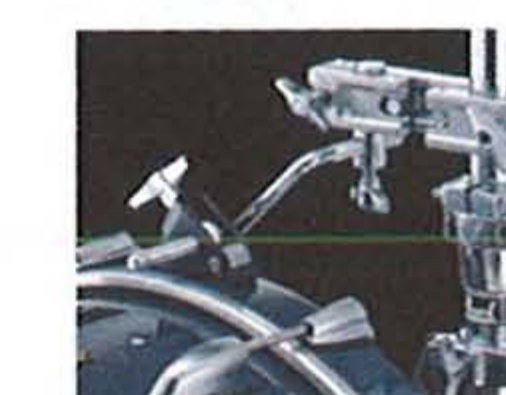

PowerShifter
ELIMINATOR

ELIMINATOR
HI-HAT STAND
H-2000

ELIMINATOR
REMOTE HI-HAT
RH-2000

H-1000

H-1000K

H-820W

H-72W

HI-HAT STANDS

MODEL	ELIMINATOR SERIES		1000 SERIES		800 SERIES	70 SERIES
	H-2000	RH-2000	H-1000	H-1000K	H-820W	H-72W
DRIVE	PosiLink Twin Cam Drive Interchangeable Cam		Direct Pull	Roller Pulley System	Direct Pull	
POWERSHIFTER	•	•	---	---	---	---
FOOTBOARD	TractionPlate & TractionGrip		TractionPlate & TractionGrip			
FOOTBOARD ANGLE	VariSet Footboard Angle Adjustment		Footboard Angle Adjustment		---	---
CLUTCH	SuperGrip Clutch w/ Lock Nut	Drop Clutch	Standard Clutch w/ Lock Nut		Standard Clutch	
SPRING TENSION ADJUSTMENT	•	•	•	•	•	---
SWIVELING LEGS	•	•	•	•	•	---
LEG TIPS	Push Button Convertible (Spike / Rubber)		Reversible (Spike / Rubber)		Rubber	

PEARL ADVANCED HARDWARE SYSTEMS

SNARE STANDS

Our Snare Stands are available with a wide range of options and features. From our lightweight easy to carry S-70W for the local gig, to our studio flagship, S-2000. Each one of our stands are task specific and cradle your prized snares perfectly in the optimal playing position.



ALL FIT SNARE STAND
S-2000



ALL FIT SNARE ARMS
The all-fit snare arms found on our S-2000 allows individual adjustment of the snare arms to fit drums from 10" to 16". This unique feature also allows the offset placement of your drum for total positioning control. The patented (US.PAT.6710236) Air Suspension rubber tips securely cradle your prized snares without applying unnecessary pressure to the shell. This offers security for your snare without compromising resonance and sustain.



GYROLOCK TILTING SYSTEM
The GyroLock tilter allows complete tilt control over your snare angle. The UltraGrip wingnuts make adjustments quick and sure.

PUSH BUTTON CONVERTIBLE RUBBER TIP
The S-2000 features convertible rubber/spike tipped feet that allow your stand to adapt to any playing surface. A push of a button releases recessed spike tips that provide maximum bite on carpeted surfaces. A second button returns them to their recessed position for contact with the large, non-slip rubber feet. (PAT.PEND)

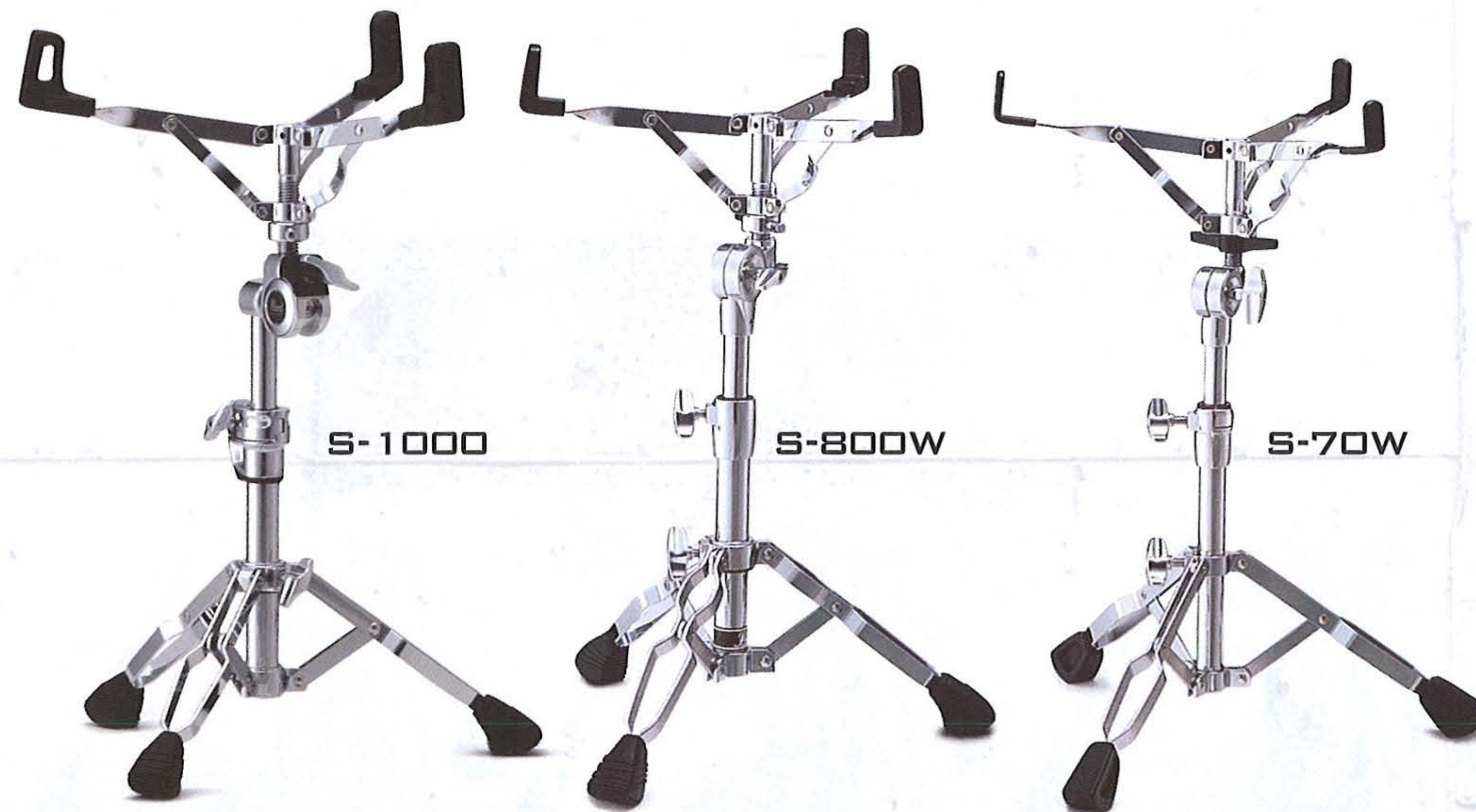

SNARE STANDS

MODEL	S-2000	S-1000	S-800W	S-70W
HEIGHT(mm)	450 - 630mm		490 - 670mm	435 - 650mm
SIZE	10" - 16"	12" - 14"		13", 14"
TILTER	GyroLock		Gear System	
ARM TIPS	Suspension Rubber Tips		Rubber Tips	
LEGS	SureStrut / Center Braced Legs		Double Braced Legs	
LEG TIPS	Push Button Convertible Rubber Tips		Rubber Tips	



**SBA-1
SNARE BASKET ADAPTER**

The SBA-1 attaches quickly to the tips of the S-800W snare stand to accept a broader range of snares including Sopranos and Effects Snares to 10". Rubber inserts prevent the snare from slipping. Sold in packs of 3.

Hundreds of Snares, One Snare Stand



DRUM THRONES

Pearl's line of thrones has something for every drummer. No other part of your kit affects your mobility like your throne.

Our Roadster line of thrones feature ergonomic accents that promote good posture and comfort during extended playing. Our new D-2000BR has a built-in backrest that is reversible for a range of playing positions.

The D-1000SP has a built-in shock absorber to cushion the energy normally absorbed by your spine and fend off fatigue. For maximum mobility and energy look to Pearl thrones.



ROADSTER THRONE
D-2000

ROADSTER THRONE
D-2000BR



ROADSTER THRONE
<SHORT TYPE>
D-1000S

ROADSTER THRONE
D-1000

ROADSTER THRONE
<VELVET>
D-1000C

ROADSTER THRONE
<SUSPENSION TYPE>
D-1000SP

D-80

D-75

D-70W

Our ergonomic seat provides two unique seating options. Firm padding with a smooth channel in the center can be used with the channel facing forward or backward to suit your personal preference. (D-2000BR / D-2000)



The quick release height adjustment clamp features a fine tuner for perfect positioning and maintains your seat position. (D-2000BR / D-2000 / D-1000 / D-1000S / D-1000C)



The built-in shock absorber takes the load off your spine and prevents premature fatigue. (D-1000SP)



The spring tension is quickly and easily adjustable for your preferred level of cushion. (D-1000SP)



The super strong clamp offers vice-like service and dependability. (D-75)



DRUM THRONES

MODEL	D-2000BR	D-2000	D-1000	D-1000S	D-1000C	D-1000SP	D-80	D-75	D-70W
HEIGHT(mm)	490 - 650mm		470 - 630mm	425 - 580mm	470 - 630mm	500 - 660mm	500 - 660mm	430 - 680mm	430 - 650mm
SEAT	PVC		PVC		Velvet	PVC	Saddle / PVC	PVC	
LEGS	SureStrut / 4-Center Braced Legs		SureStrut / 3-Double Braced Legs			3-Double Braced Legs			
	Back Support		Short Type		Build-in Shock Absorber				

CYMBAL STANDS

Pearl cymbal and boom stands are the choice of the working drummer. Solid and strong with brilliant chrome finishes that ensure a long life and dependable service. Available with a wide range of options to fit your every need. Our all new line of Advanced Hardware Systems has revolutionized the world of drumming hardware. From the studio to the stage, you can count on Pearl hardware.

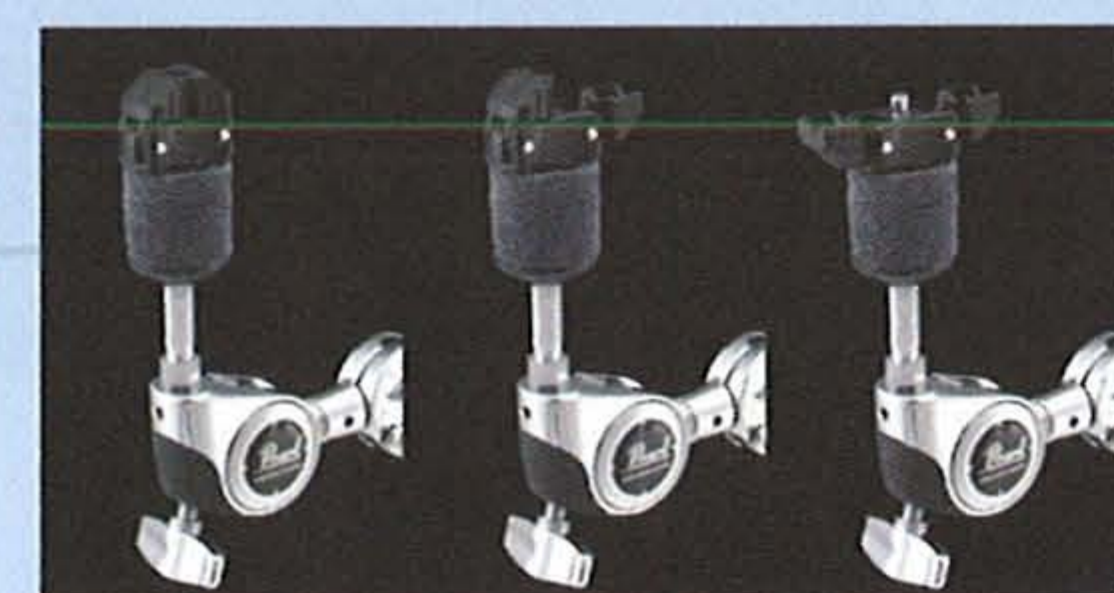

WINGLOC (PAT.PEND.)
Our new WingLoc makes old fashioned wingnuts a bleak memory with its snap on, snap off ease of use. Whereas traditional wingnuts have to be manually unscrewed or screwed tighter, the WingLoc just slides onto a cymbal holder and snaps together to hold the cymbal firmly in a matter of seconds.

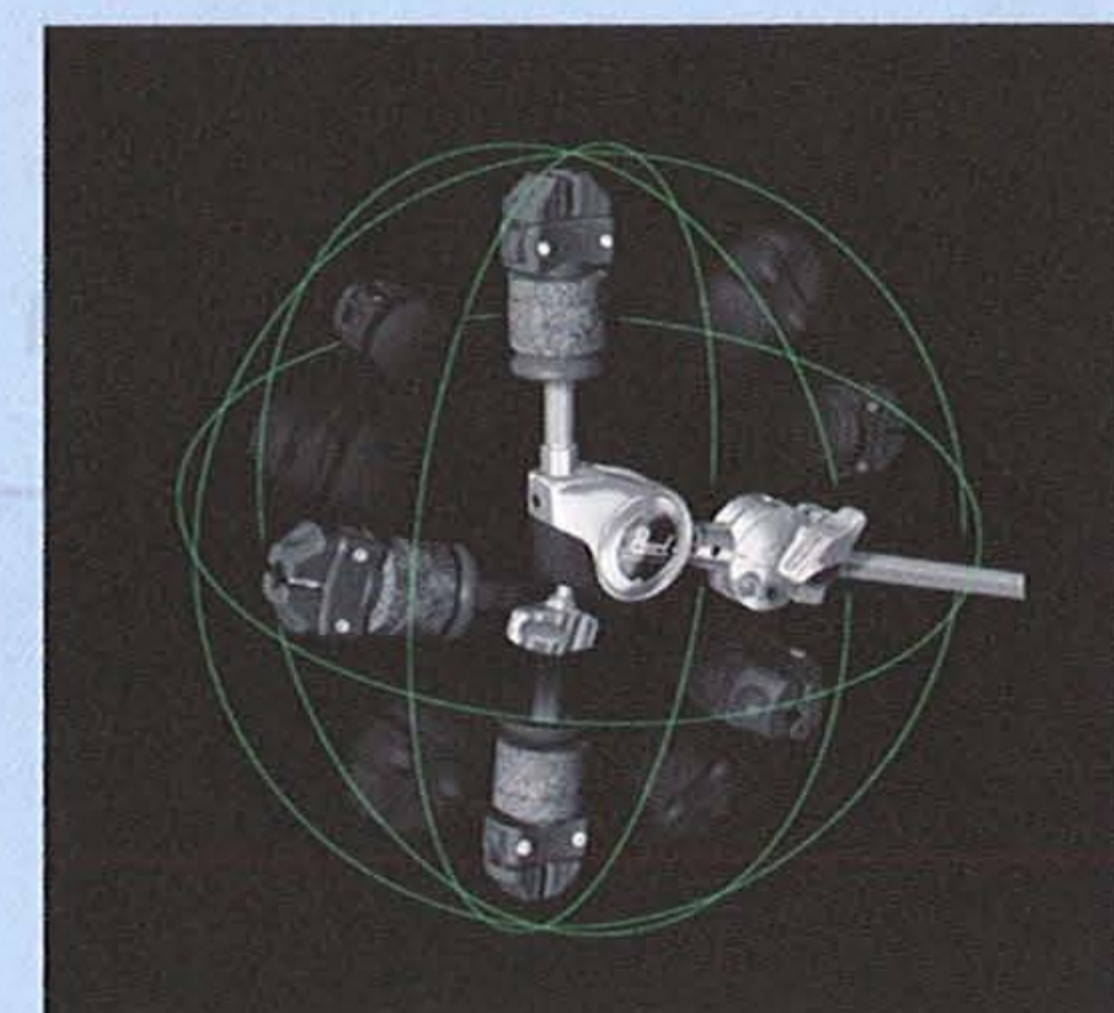

GYROLOCK & UNI-LOCK
GyroLock allows a full 360° range of motion. Tom and cymbal positioning has never been this precise. Another standard feature of our revolutionary BC-2000 boom stand. Set it. Lock it. Play it!

Our newly re-designed Uni-Lock cymbal tilter provides a wide range of positioning options and locks securely with a twist of an UltraGrip WingNut.



SETTING
The BC-2000 offers so many diverse mounting possibilities. With a built-in knurled post, it's perfect for adding cowbells or percussion effects. Add on some additional TL-2000 GyroLock Tilters and mount multiple cymbals on the same boom tilter.

DETACHABLE COUNTER WEIGHT
The Detachable counterweight ensures perfect balance and stability.

DIE-CAST JOINT
Our newly designed clamp provides solid and dependable positioning while the hidden nylon bushings inside the tubes prevent metal to metal contact eliminating the squeaks that can be produced from some hardware.

SURESTRUT & STOPLOCK
The BC-2000 also features our double strut legs to prevent lateral movement and positive stop memory locks for repeatable height settings.

OVERSIZED NON-SLIP RUBBER FEET
The over-sized non-slip rubber feet are the foundation of the BC-2000's stability. They provide sure footing and absorb unwanted overtones.

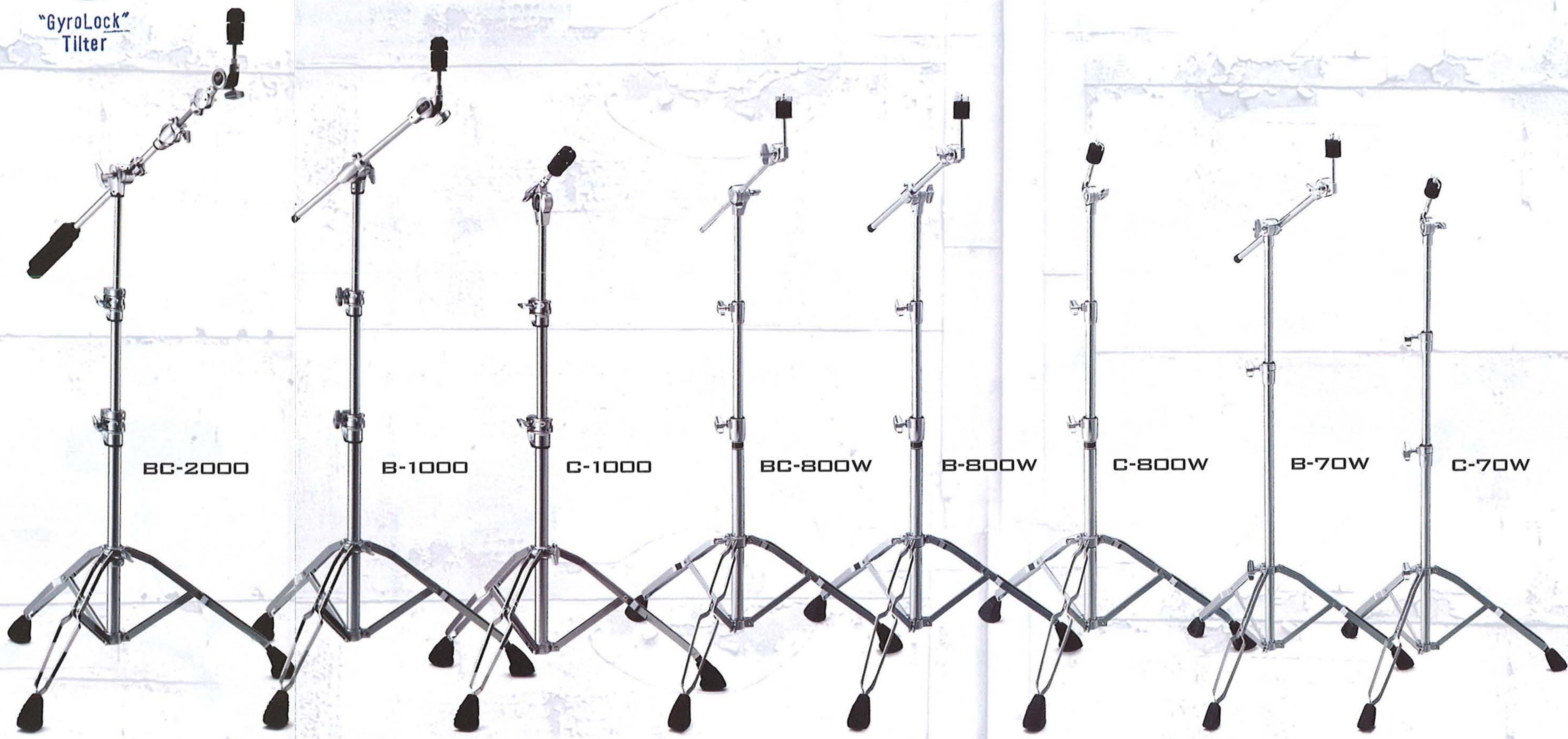
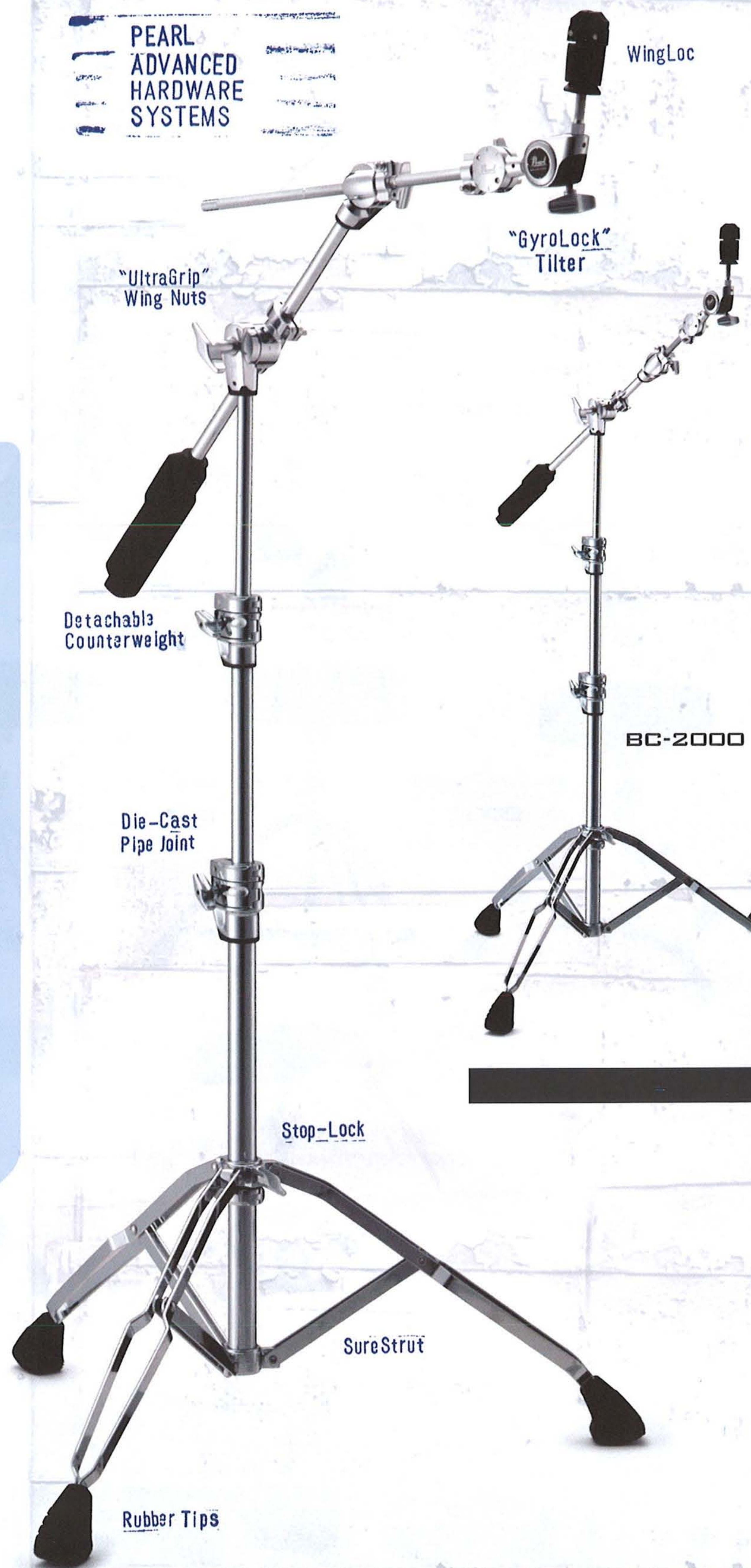
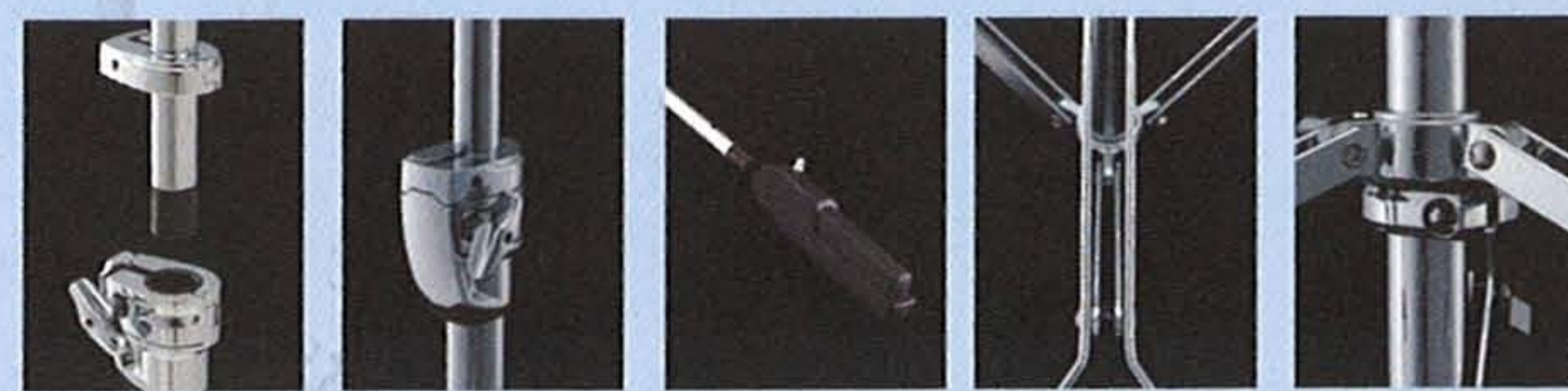

MODEL	2000 SERIES			1000 SERIES			800 SERIES		70 SERIES	
	BC-2000	B-1000	C-1000	BC-800W	B-800W	C-800W	B-70W	C-70W		
CYMBAL TILTER	WingLoc			Wing Nut, Vinyl Tube, Felt		Steel Washer				
PIPE JOINT	GyroLock			Uni-Lock		Gear System				
LEGS	Die-cast Joint w/ Stop Lock			Die-cast Joint		Nylon Bushing Joint				
PIPES	SureStrut / Double Braced Legs			Double Braced Legs		Double Braced Legs				
	28.6 / 22.2 / 15.9 mm			28.6 / 22.2 / 15.9 mm			22.2 / 19.1 / 15.9 mm			

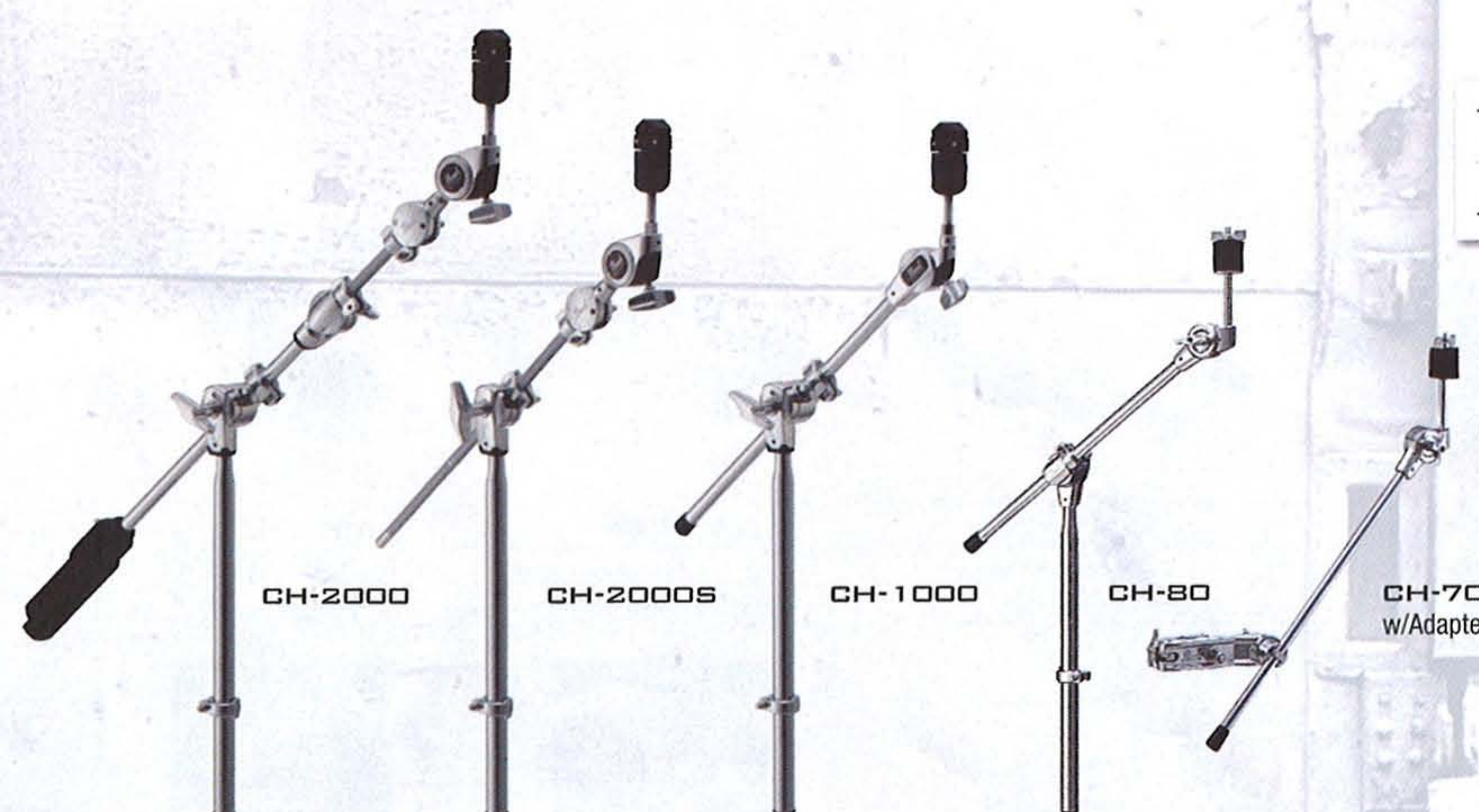

CYMBAL HOLDERS					
MODEL	CH-2000	CH-2000S	CH-1000	CH-80	CH-70
DIAMETER	22.2mm			15.9 - 28.6mm	



The Cymbal Stacker with dual angle tilters allow the mounting of multiple cymbals on the same stand. Cool angles and lots of options for a whole new world of cymbal placement.
Fits B-800W, C-800W, BC-800W, C-70W, B-70W, CH-80

DRUM RACKS

Pearl's **ICON Series** set the standard for drum racks. Its patented square Aluminum tubing allow clamps to hold without turning or sliding. Each section is independently height adjustable. Our clamps feature hinged quick release jaws for fast set up and tear down. The new **DR-501C** has an unique curved bar that allows your drums and cymbals to flow smoothly around your set, providing a natural feel. You can continue the look by adding the matching side expansion bars or the traditional straight bar. You can even inverse the curve for more placement options.



**ICON 3-SIDED RACK
DR-503**
w/ PCX-100(4), PCL-100(2)



**ICON FRONT RACK
DR-501**
w/ PCX-100(2), PCL-100(2)



**ICON FRONT RACK
DR-501C**
Curved Bar,
w/ PCX-100(2), PCL-100(2)

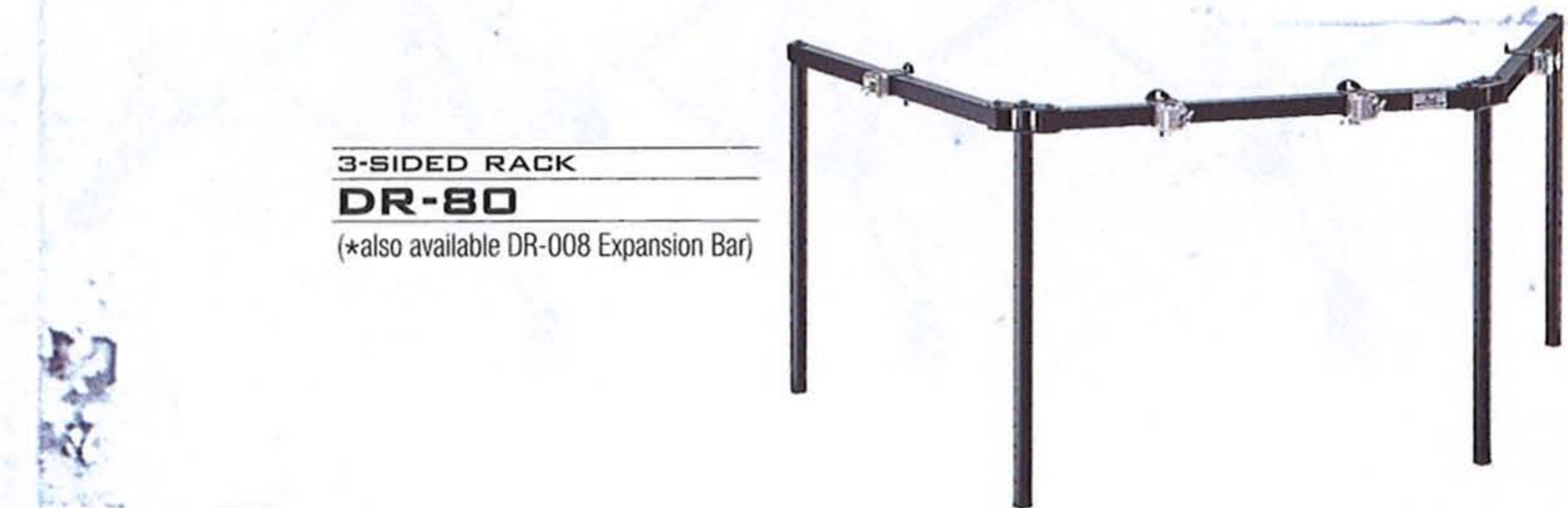

**3-SIDED RACK
DR-80**
(*also available DR-008 Expansion Bar)



**ICON EXPANSION BAR
DR-501E**



**ICON EXPANSION BAR
DR-501CE**



**PIPE CLAMP
PCX-100**
Clamping System
w/Adjustable Jaw
for ICON/110/210

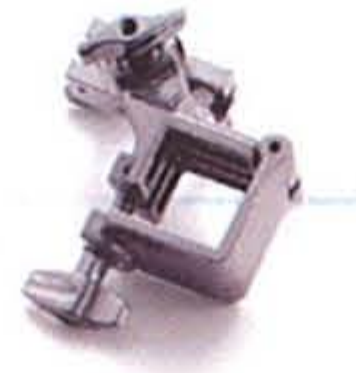

**PIPE CLAMP
PC-8**
fits 7/8" tubes,
for DR-80



**ICON 6" MINI-EXPANSION BAR
RJ-50**



**PIPE CLAMP FOR LEG
PCL-100**
fits all ICON Rack Leg Posts



**PIPE CLAMP FOR LEG
PCL-100**
fits all ICON Rack Leg Posts

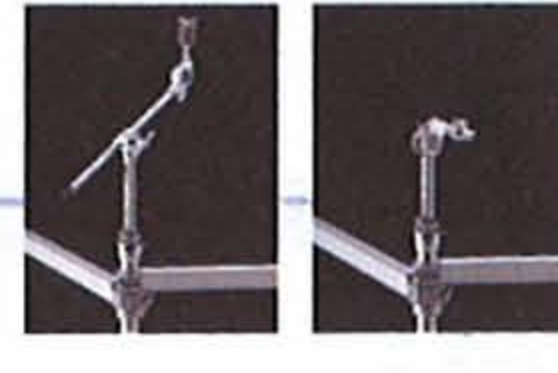

**PIPE CLAMP FOR LEG
PCL-100**
fits all ICON Rack Leg Posts

ADAPTERS



AX-20
2 Clamps
fits 5/8"-1-1/8"

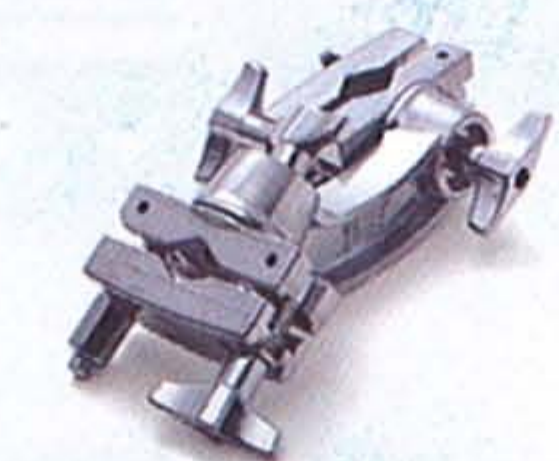

AX-25
2 Revolving Clamps
fits 1/2"-1-1/8"



AX-25L
2 Revolving Clamps
fits 1/2"-1-1/8"

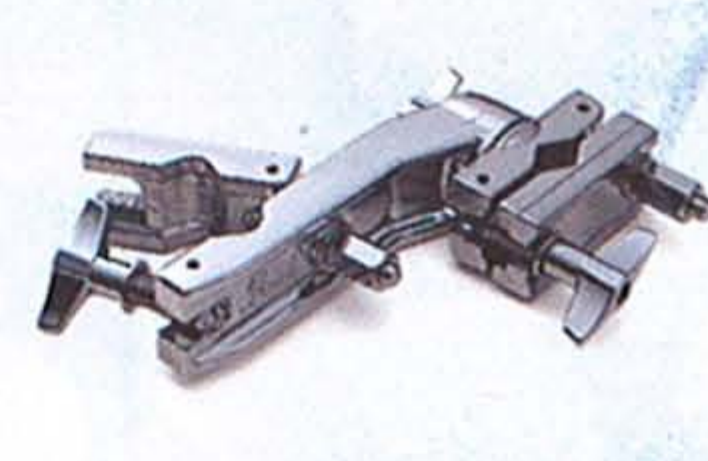

AX-28
In-Line & Revolving Clamps
fits 5/8"-1-1/8" & 1/2"-1-1/8"



AX-38
fits 3/8" - 1-1/4"
3 Adjustable Clamps

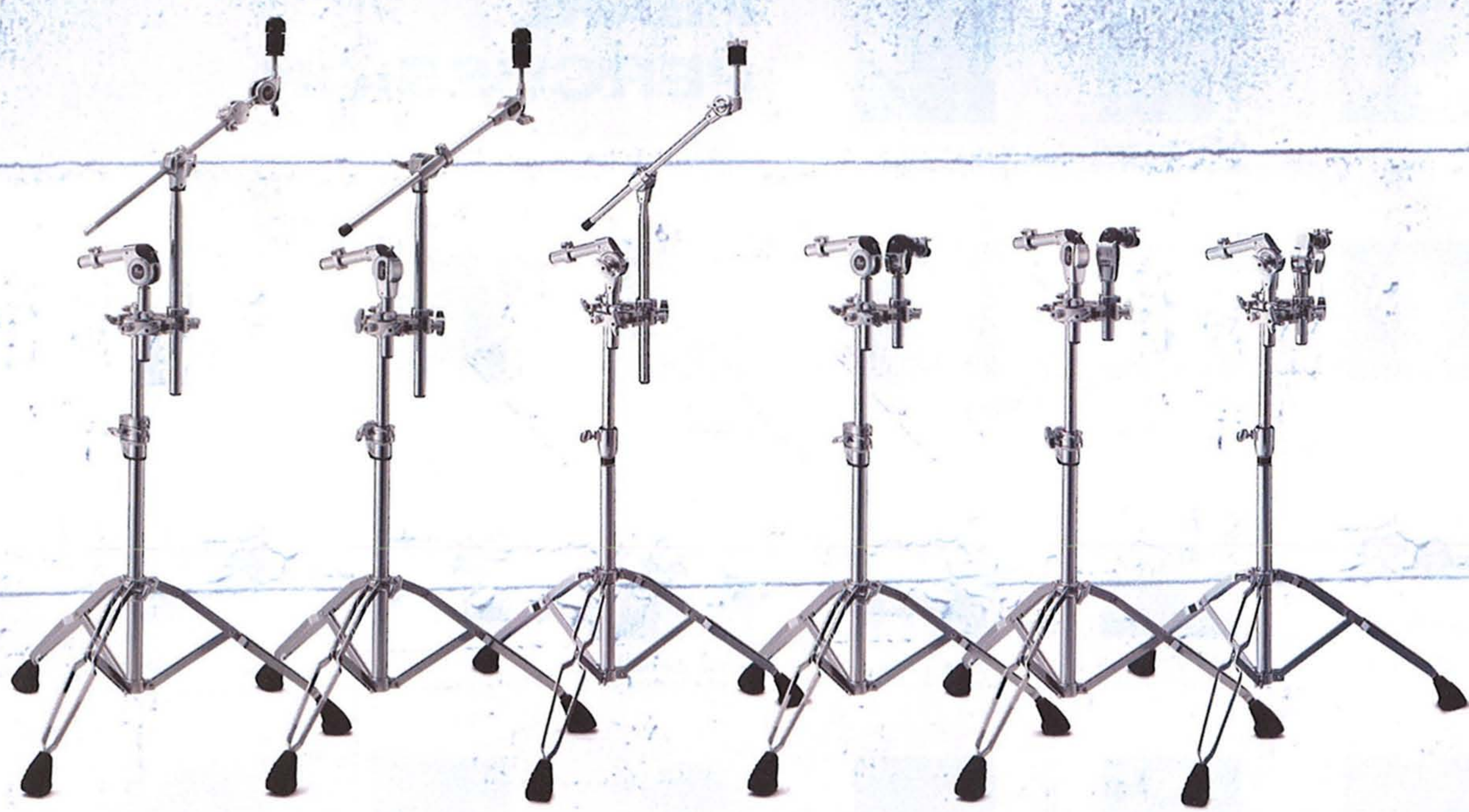
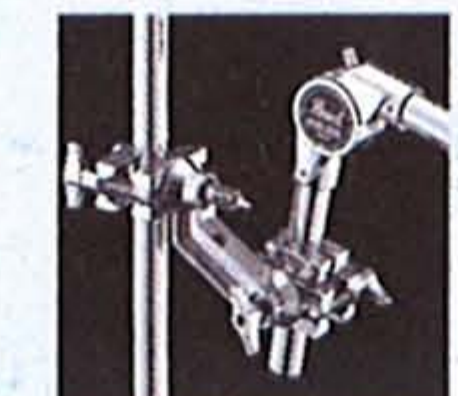
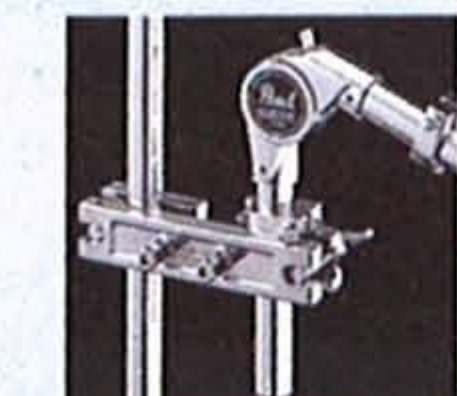

COMBINATION STANDS			DOUBLE TOM STANDS		
GYROLOCK	UNI-LOCK	GEAR	GYROLOCK	UNI-LOCK	GEAR
TC-2000	TC-1000	TC-800W	T-2000	T-1000	T-800W
w/ TH-2000S, CH-2000S	w/ TH-1000S, CH-1000S	w/ TH-88S, CH-80	w/ TH-2000S(2)	w/ TH-1000S(2)	w/ TH-88S(2)

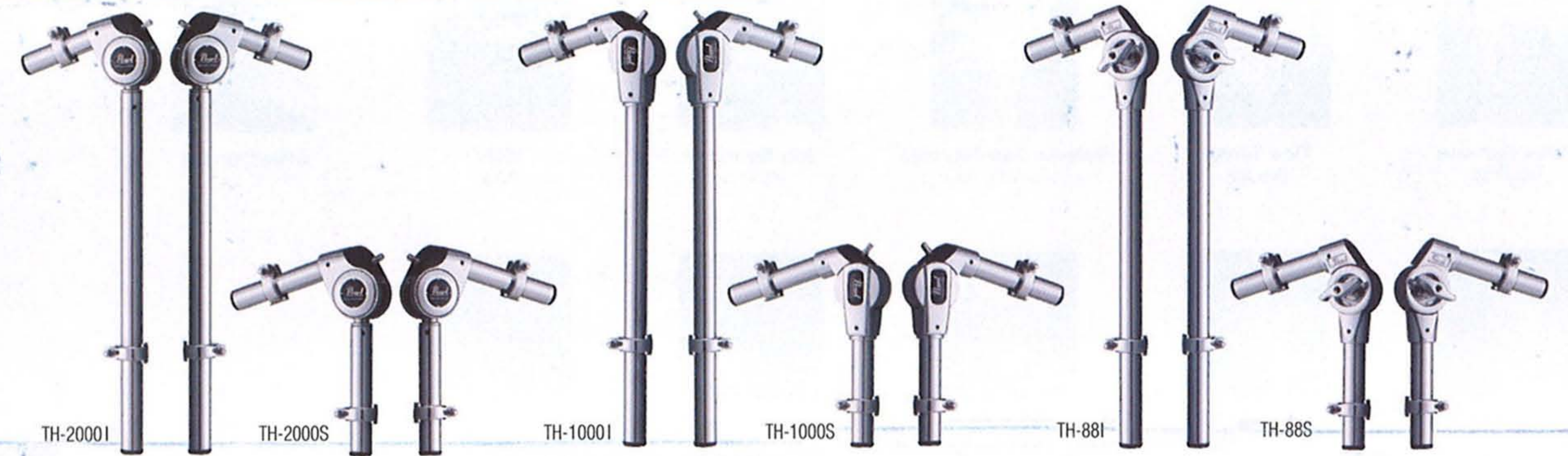

TOM HOLDERS		TOM HOLDERS		TOM HOLDERS	
GYROLOCK	UNI-LOCK	GYROLOCK	UNI-LOCK	GEAR	GEAR
2000 SERIES	1000 SERIES	2000 SERIES	1000 SERIES	88 SERIES	88 SERIES
TH-2000	TH-1000	TH-2000	TH-1000	TH-88	TH-88
TH-2000 I	TH-1000 I	TH-2000 I	TH-1000 I	TH-88 I	TH-88 I
TH-2000S	TH-1000S	TH-2000S	TH-1000S	TH-88S	TH-88S



UNIVERSAL CLAMP
UX-80 13" Long Tube
UX-80S 4" Long Tube

HEIGHT EXTENDER
TX-100 13" Long Tube

COWBELL HOLDERS	
CA-100	75H
Hoop Mounted, Adjustable L-Arm	Hoop Mounted



COWBELL HOLDERS		
75X	PPS-30	PPS-37
7/8" Dia Tube	3/8" Post	Multi-Angle "L" Arm

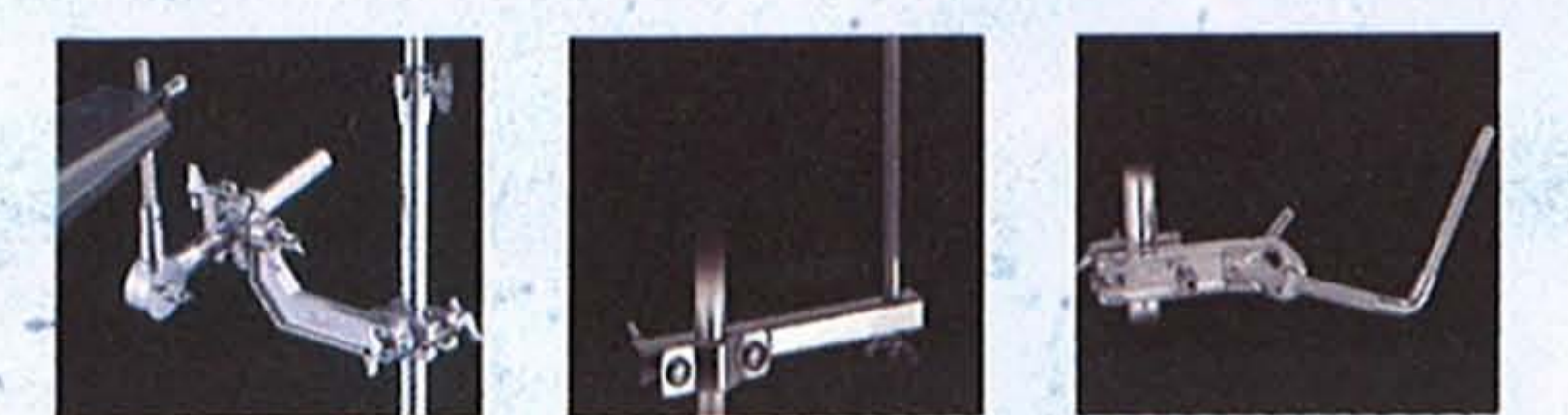

TOM STANDS TOM HOLDERS

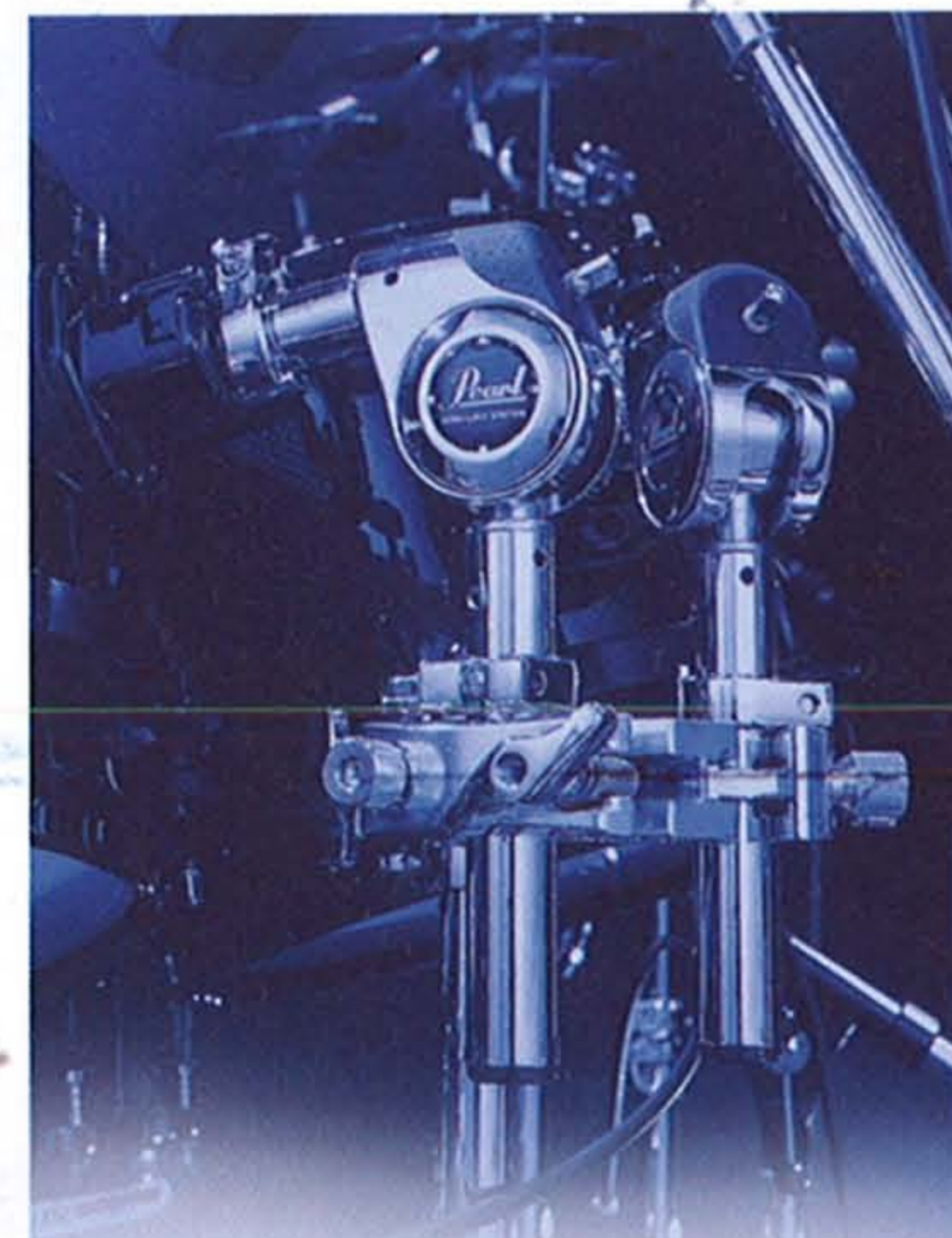

Our Advanced Hardware Systems **TH-2000** and **TH-1000** Tom holders provide positioning capabilities never before available. Large non-slip rubber feet and No rattle tubes make our tom stands the studio kings.



GYROLOCK & UNI-LOCK
The TH-2000 utilizes our new GyroLock tilter that opens up a 360° range of movement. The TH-1000 uses our dependable UniLock tilter.



Archie Pena
Gloria Estefan



Bobby Allende
Santana



Cesar Espinoza
Orquesta Tabaco Y Ron



Eric Velez
Marc Anthony

PEARL PERCUSSION



Etienne Fuentes
Chayanne



Fausto Cuevas
Britney Spears



Future Man
Bela Fleck



Horacio Hernandez



Jesus Diaz
QBA/Cuban Jazz Project



Jimmy DeGrasso



Johnny Blas



Johnny Conga



Lalo Davila
MTSU



Marc Quiñones
Allman Brothers.



Mat Britain
Britain/Moore Duo



Michael Cartellone
Lynyrd Skynyrd



O.G.
Slightly Stoopid



Olbin Burgos
Gloria Estefan



Omar Hakim



Ravi Jakhota
Ravi Drums



Ray Barretto



Richie Bastar
El Gran Combo



Richie Flores



Robert Vilera



Rolando Morales-Matos
Lion King Broadway



Sammy Garcia
Puerto Rico



Steve Ferrone
Tom Petty



Tico Torres
Bon Jovi



Valerie Dee-Naranjo
Lion King / SNL

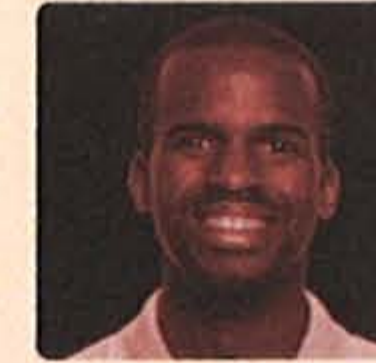

Will Kennedy
WK Krew



WUV
P.O.D.



Glen Caruba



Bart Fermie



Lucas van Merwijk



Martin Verdonk



Nils Fisher



Dawne Adams
Pet Shop Boys



Pablo Escayola
James Last Orchestra

Signature Series

Marc Quiñones Signature Timbales Set ETE-1415MQ

Designed in conjunction with one of today's premier percussionists, Marc's timbale set consists of standard 14 and 15 inch drums fitted with Remo Clear Ambassador heads, and packed with a ton of innovative features that only Pearl can deliver. The Polished Steel Shells have two inverse beads that not only add strength, but also produce a cutting "cascara" sound (side of the shell) not hindered normally by outward facing beads. To further the "cascara" striking area, this set features a 5-Lug Design that is proportioned perfectly for leaving maximum shell space and less lug interference. Tuning is easier than any other timbales on the market, utilizing a top tuning lug design with included socket wrench. This exclusive Pearl design, cuts the time changing heads in half - No more nuts and washers falling on the floor! The cowbell post features a Sympathetic Sound Dampening sleeve so your cowbells and blocks do not ring through the stand, and the whole unit can be mounted in seconds using a one wing-nut design. A double braced tilting stand, and our top-selling PBL-20 Clave Block are included.



Marc Quiñones Signature
Timbales Set

Richie Flores Signature Oak Congas and Bongos

PCW-100DXRF 10" Re-Quinto **PCW-110DXRF** 11" Quinto
PCW-117DXRF 11.75" Conga **PCW-125DXRF** 12.5" Tumba
PBW-300DXRF 7 & 9" Bongos

If you are in search of the authentic sound of wood, Richie's Oak Congas and Bongos will appeal to you. Designed by one of the most technically proficient conga players around, Richie (in collaboration with his wife Jennifer Delgado) has finished his drums with a Caribbean Lime base accented by ancient Aztec, Incan, and Mayan symbols. All the symbols signify positiveness that will transcend from your hands to your audience. Based off our popular Elite drum designs, we added a 10" Re-Quinto for those wanting the added flavor of a higher pitched "solo" drum. Complete with Natural Buffalo skins, Richie's signature series will surely catch the eyes and ears of all styles of percussionists.



Richie Flores Signature
Oak Congas and Bongos
#525 Tilo Green

Bobby Allende Signature Fiberglass Congas and Bongos

PCF-110DXBA 11" Quinto **PCF-117DXBA** 11.75" Conga
PCF-125DXBA 12.5" Tumba **PBF-300DXBA** 7 & 9" Bongos

He demands the best so he designed his Signature Congas and Bongos to exceed all existing standards, right down to the smallest details. For example, the seams are invisible thus giving his Fiberglass congas the look of wood. The congas are 28" tall to fit the traditional seated player and the wider base adds projection and stability. A new rim design on both congas and bongos adds extra comfort while complimenting the fitted Remo Fibreskyn3 heads.

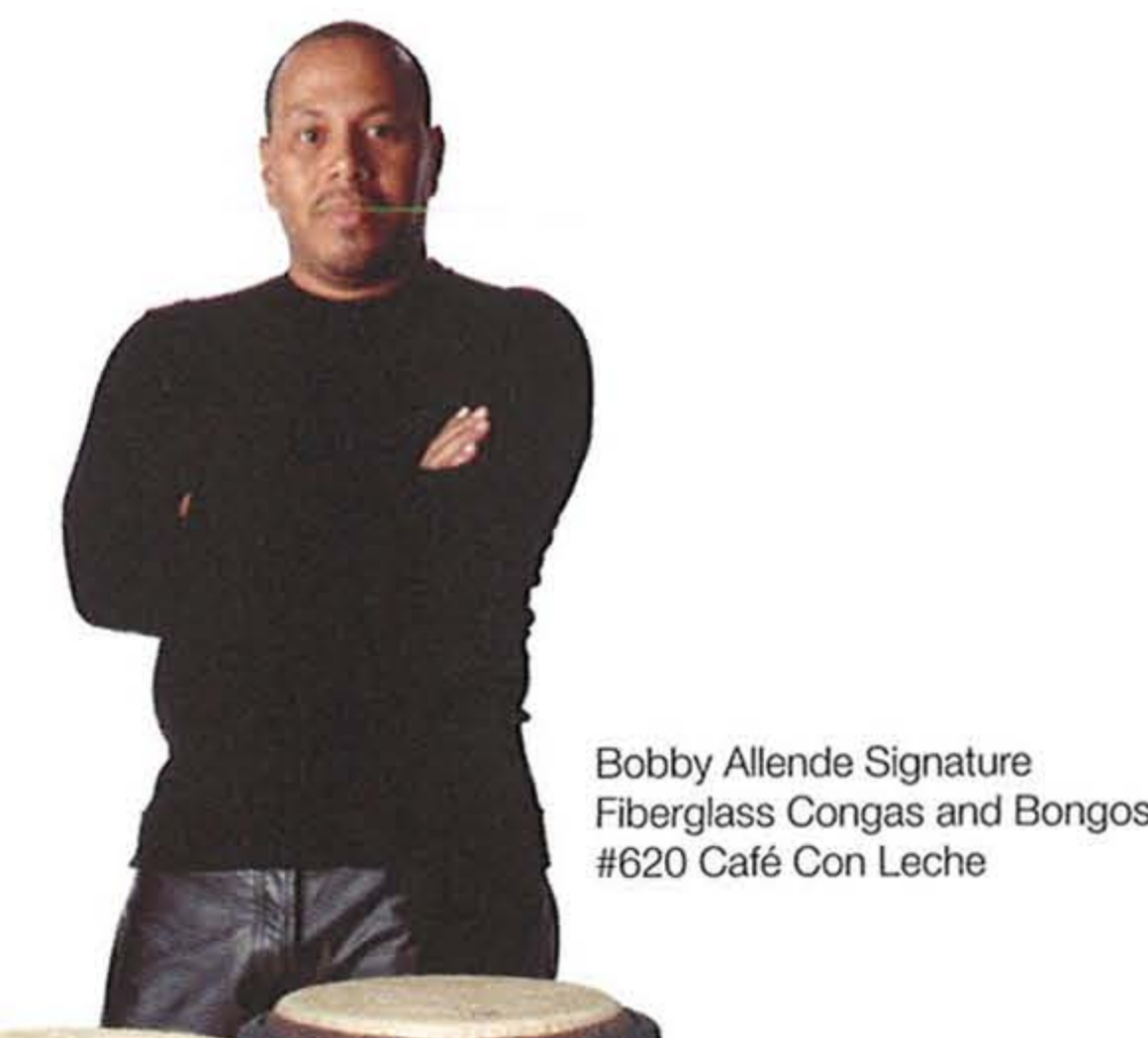

Bobby Allende Signature
Fiberglass Congas and Bongos
#620 Café Con Leche



Horacio "El Negro" Hernandez Signature COWBELLS

Designed by Horacio Hernandez, this series of five cowbells are pitched in accordance to "El Negro's" strictest of standards. Intended for Drumkit and Percussion players, the unique features include two playing surfaces: flat on one side, and curved on the other. The tone is the same, but the distinctive bi-shaped design will give the player the option of striking the bell directly facing in or the side (like a timbale player). The two-position cowbell bracket will ensure that the wing-nuts will not get in the way when stacking multiple bells and blocks on one post. This makes it much easier to adjust the bells from virtually any position. Another exclusive feature is found on the smallest bell, the HH-1 Bella two rubber gaskets separate the mount from the body of the bell offering maximum tone and resonance that is usually "choked" and "dry" with other cowbells of this size. Finished in beautifully plated copper, this professional line of cowbells sound and look like no other on the market.



- HH-1 BELLA Hi-pitch Cha-Cha bell
- HH-2 ClaBELL Foot-Clave bell
- HH-3 ChaBELLa Low-pitch Cha-Cha bell
- HH-4 IsaBELL Mambo bell on BD
- HH-5 MaryBELL Timbale bell



NEW
PPS-20 Cowbell Footpedal Bracket with HH-2 and P-2000C
The new PPS-20 features squared dimples post for maximum support without the "L" rod slipping. Eye-bolts/wings and knurled pegs which are reversible; rubber tip or spike.

Elite Oak Congas
#522 Diamond Burst



PCW-125DX 12-1/2" Tumba
PCW-110DX 11" Quinto
PCW-117DX 11-3/4" Conga

Elite Fiberglass Congas
#625 Lunar Blaze



Primero Pro Oak Conga Set

PWC-202DX
10/11"
#521 Midnight Fade



PC-110DX 11" Basket Stand
PC-100DX 10" Basket Stand

Primero Pro Fiberglass Conga Set

PFC-202DX
10/11"
#615 Majestic Haze



10" / 11" / 12"
#630 Red Sparkle

Primero Oak Congas Set

PWC-202
10/11" #511 Natural



PC-200W
Twin Conga Stand

Primero Fiberglass Congas Set

PFC-202
10/11" #610 Deco Blue



PC-110P 11" Basket Stand
PC-100P 10" Basket Stand

Congas

Pearl has congas for every application. Our Elite Series offers the highest quality heads with polished Contour Crowns and a choice of shell materials, 100% aged Oak or seamless Fiberglass. Our Primero Pro line features professional quality construction at an affordable price and a choice of 100% Oak or Fiberglass. Primero offers even more affordable instruments with authentic features and a choice of 100% Oak or Fiberglass.

Practice Conga

PPC-120 Practice Conga w/Video

The perfect learning tool for the on-the go percussion student or for the seasoned pro warming up backstage. It includes a Velcro strap to secure it to your lap and a video hosted by Glen Caruba to teach you the basics of hand percussion. Practice anywhere, anytime.



Conga Reso-Plate PRP-140

Designed for the seated conga player, Pearl's Reso-Plate will give you that hard surface desired for maximum resonance. Designed with a cutout handle, the plates can also easily be placed on top of your drum for extra protection when packed in your conga case.



Available Finishes

Elite Series

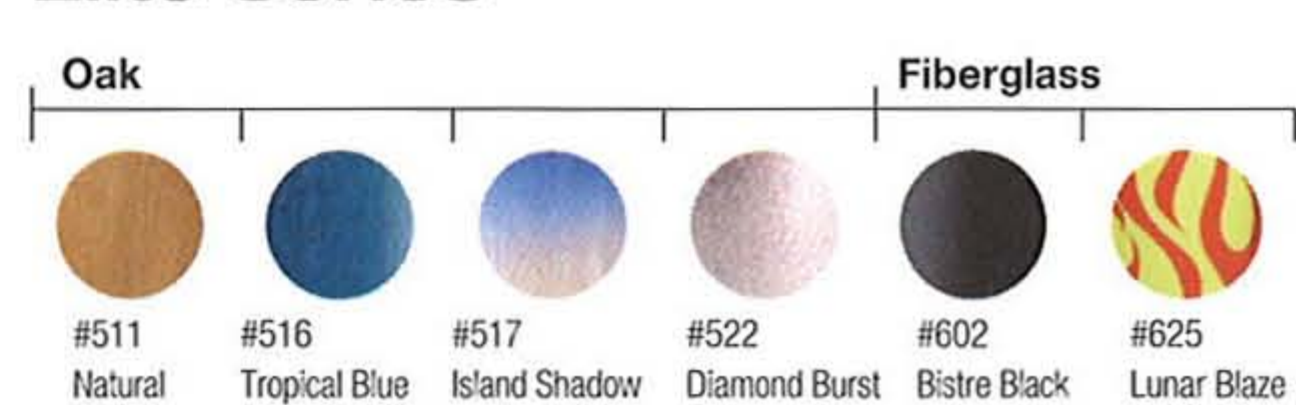

Primero Pro Series



Primero Series

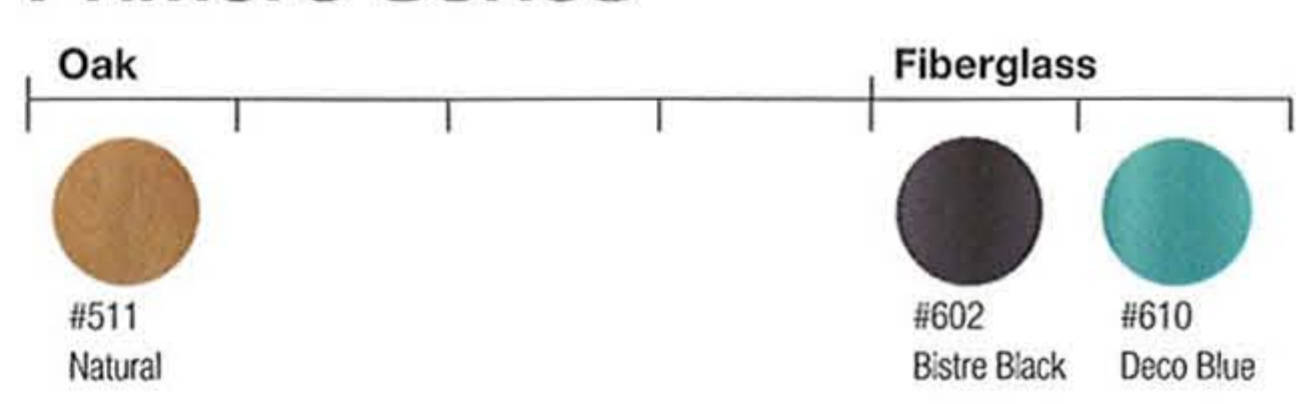

Percussion Cases

Pearl's new padded carrying cases include features like the ergo-carrying straps, rubber protective bottoms, top-mounted carrying handles, tuning wrench pouches, and heavy duty double zippers. The existing PPB100 is made from heavy weight nylon and will fit all Conga sizes.



(NEW) PSC-12CG
(NEW) PSC-11CG
(NEW) PSC10CG
(NEW) PSC-BB
Fabric Conga Bag
PPB-100

Bongos

Our Bongos offer professional features and authentic styling in a choice of shell material to perfectly match your Conga Set. Choose from 100% Oak or Fiberglass. Elite Series feature Contour Crowns, Polished Steel Hardware with a choice of 4 finishes for Oak and 2 finishes for Fiberglass. Primero Pro offers Professional features with a choice of 3 finishes for Oak and 2 finishes for Fiberglass. Primero offers maximum affordability with Black Powder-coated hardware and a choice of 3 colors, #511 Natural, #602 Bistre Black (Fiberglass) or #610 Deco Blue (Fiberglass).

Elite Oak Bongos
PBW-300DX (7" and 9" #522 Diamond Burst)



Elite Fiberglass Bongos
PBF-300DX (7" and 9" #602 Bistre Black)

Primero Pro Oak Bongos
PWB-100DX (7" and 8.5" #521 Midnight Fade)



Primero Pro Fiberglass Bongos
PFB-100DX (7" and 8.5" #615 Majestic Haze)

Primero Oak Bongos
PWB-100 (7" and 8.5" #511 Natural)



Primero Fiberglass Bongos
PFB-100 (6" and 7" #602 Bistre Black)

Timbales

Pearl offers Elite Timbales in 3 different sizes, 13", 14" and 15". These professional Timbales feature brass shell construction that provides the ultimate Timbale voice. The exclusive 7.5" depths with rolled bearing edges provide cutting "cascara" while the powder coated steel hardware provides classic rimshots and the ultimate in tuning integrity. Our Primero Timbales offer a traditional smooth steel shell in 13"/14" sizes. Sold complete with a tilting stand, sticks and cowbell, you're ready to play.

Primero Flat Timbs



PTB-313I Flat Timbale w/I.S.S. (Brass)
PTE-313I Flat Timbale w/I.S.S. (Steel)



Elite Timbales
ETB-1415
Brass Shell 14"/15" w/PT-900W

Elite Timbales



ETB-13 13" Brass Shell
ETB-14 14" Brass Shell
ETB-15 15" Brass Shell



Primero Timbales

PTS-5134
13"/14" Steel w/Tilting Stand
•Tilting Stand
•Sticks & Cowbell Included

Djembes

Djembes are a traditional African instrument that offers a variety of sounds and are perfect for drum circles. The Professional Elite Series offers a choice of Oak or Fiberglass in 12.5" sizes or a 14" Fiberglass. All have our Contour Crowns and authentic Goat skin heads. Our Primero Djembe is 9.5" Fiberglass and available in a choice of 2 colors. Perfect for the beginning percussionist. New for 2005 is the hide-away djembe stand (PHD-1000) which is the ultimate in portability and ease-of-use. The PHD-1000 stays attached to the drum for transport (it fits virtually all styles and brands) and sets up in seconds by simply swinging the legs outward. The stand includes a side handle for ease of transport.



Elite Oak Djembes
PJW-340
12 1/2" #511 Natural



Elite Fiberglass Djembe
PJF-350 14"
PJF-320 12 1/2"
#602 Bistre Black



Primero Fiberglass Djembe
PJF-310
9 1/2"
#610 Deco Blue



Elite Batas
#511 Natural

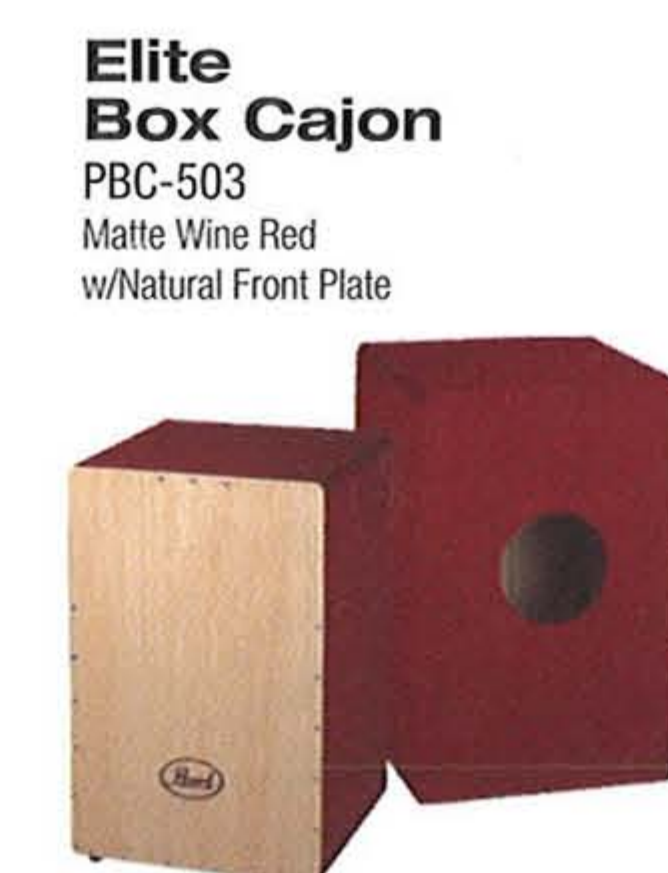

Elite Box Cajon
PBC-503
Matte Wine Red
w/Natural Front Plate

Elite Tube Cajons
#511 Natural



PCJ-120 12" Thai Oak
PCJ-100 10" Thai Oak
PCJ-140 14" Thai Oak

Batas

Based off of traditional Cuban design, these folkloric instruments offer modern day tuning and construction while maintaining the purist of tone and playability. 100% Oak and available in 3 sizes: Oconcolo is 19" in length, Itotele 26", and Iya 27".

Stands

Pearl offers stands for every application, from our economical and lightweight PC-900 stand that accommodates a range of instruments to our PC-1000 QRS Multi stand that provides a solution for all of your instruments. QRS offers full height adjustability and adapters to fit Bongos, Congas, Djembes and Timbales. You can even make it mobile by adding our PC-1000 CA/3 caster set.

New stands for 2005

The PB-500 Seated Bongo Stand is a comfortable solution to the traditional bongo player's strain of having to hold the weight of the bongos between their legs. The new PC-900S Conga Stands low mass foldable stands will raise your drums a few centimetres off the floor, just enough to give you improved bass tones.



(NEW) Djembe Stand
PHD-1000



Quick Release Multi-Stand
PC-1000QRS
Basic Stand
for Congas & Djembes

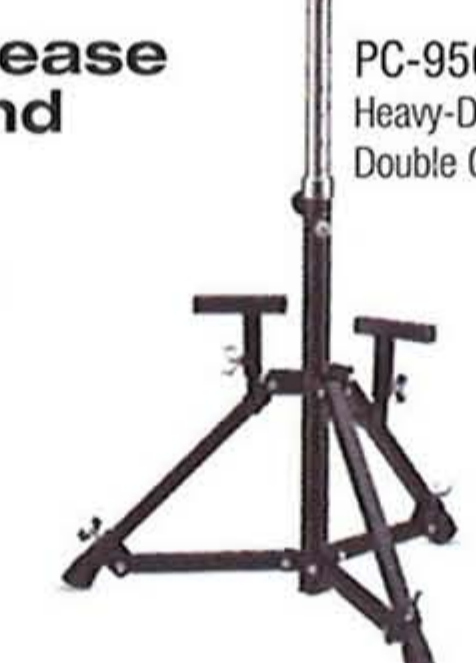

PC-950TW
Heavy-Duty Double Conga Stand



PB-900W
All-fit Tilting Bongo Stand



PB-700
Lightweight Bongo Stand



(NEW) PB-500
Seated Bongo Stand



(NEW) PC-900S
Conga Stand



PC-1000TC
Timbale/Cowbell Adapter



PC-1000BB
Bongo Bracket



PC-1000BA
Bongo Adapter

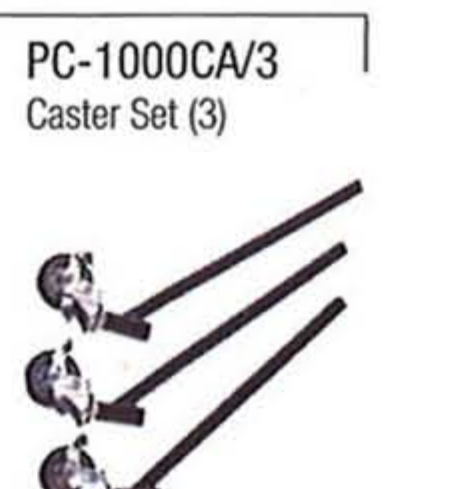

PC-1000CA/3
Caster Set (3)

Cowbells

Pearl cowbells come in a broad array of sizes and shapes. The perfect effect for drum set players, cowbells offer diversity and flavor to your kit sound. And nothing completes that Salsa sound like a quality cowbell. Our Bala cowbells are the most detailed on the market today. These cowbells offer pure undiluted power and clarity all finished in a highly polished, seamless design. Available in 5 different mountable sizes and 1 handheld model. Our Elite Series Cowbells are available in 8 different sizes and feature smooth Argon welds and a tough black finish. Engineered for maximum projection and clear cutting sound without unwanted overtones, Elite Cowbells are the perfect complement to your Congas or Timbale Setup. Primero Cowbells are available in 2 sizes, 4" and 6". Each offer great tone, superb volume and sturdy mount. The best value available in a cowbell.

Hand Percussion

We offer an ever-expanding line of effects to add flavor and color to your sound. Cultural instruments from around the world are available, many of which offer bold improvements over the traditional. Our synthetic Fiber Claves produce cutting clave and unlike traditional Rosewood designs never shift in pitch and are virtually indestructible. Our Fiber Guiro is strong and resilient compared to organic gourd designs and we have a metal version which provides a unique metallic sound perfect for Merengue rhythms. Our Shakerine is a precision formed, traditional shaped, beaded fiberglass shell that optimizes projection without the fragility or weight of natural gourds. Many of our tambourines and effects use our QuickMount system that allows fast retrieval from the mount to your hand without missing a beat. Our Shakerine, Mini Shakerine and Ganzeiro combine the shaker/ganza sound with a Tambourine jingle. Both sounds can be played independently or together. New for 2005 is the three-toned Tribal shaker which has a Black Tribal Steel finish and looks as cool as its sounds. The TomBourine's are now available in 6", 8" and 10" sizes, each with a wood shell Tambourine and a 10" plastic head. They are fully tunable with a drum key and includes our QuickMount for fast, onehanded retrieval and docking. We have 2 sizes of Trap tables to keep all of your effects organized. They have a soft felt surface for quiet operation and short sides to prevent instruments from rolling off. This year we launched a new two-level folding rack (PTR-1824) add-on for the trap tables, which includes four straight and angled posts New Concert hand percussion; Pearl's high-density steel concert triangles (PET-100, PET-80, PET-60) offer beautiful clarity with no unwanted overtones. Available in 6, 8, and 10 inches, they each store safely in the included padded canvas carrying pouch which also houses a brass triangle beater (included). Accessories include the PTC-10 basic triangle clip and the revolutionary PTC-300 Trio Triangle Holder that can accommodate up to three triangles ranging from 6-10 inches. Our new Single Row, and staggered Double Row 10" Concert Tambourines (PETM-20, PETM-10) have thin stainless steel jingles in a hardwood frame and natural goat skin head. Also launched this year are a range of new concert woodblocks (PCWB-10, PCWB-20, PCWB-30) which are made of blended hardwoods and designed with a raised spine in the center for easy striking with a mallet or stick. Now available is a new starter Percussion pack (PP1-EDU) which includes the new 8" Triangle (with beater) and 9" Woodblock, as well as the fantastic PGA-32 Hex Ganza, PCL-10 Fiber Claves, 6" Cowbell, and Carrying Bag with shoulder strap!!! New innovative accessories in 2005 include the lug accessory holder PPS-40 which will mount to virtually all brands of hand-drum tension hooks and can allow the addition of a cowbell or accessory effect when space is limited. Also available is the swivel mount adapter PPS-27 which turns any straight 3/8" post into a fully adjustable infinite angled rod. Totally new and already voted Best percussion accessory in Drum! Magazine is the hand drum snare adapter PSA-10 (or snake rake) which is great for Djembes and Congas, where you can now add a snare effect quickly and easily to most brand's hand drums. When it comes to percussion effects, we have more than you can shake a stick at.



Replacement Parts

Tom Tom Bracket

The BT-3 accepts all holders using 7/8" tubing and features an internal non-marring nylon sleeve for slip resistance. Accepts SX-2 Stop-Locks.



BT-3 7/8" Receiver, UltraGrip Wingnut

Masking Cover



The GK-90 masks the holes (inside and out) on drums where the BT-3 tom bracket has been removed.

GK-90 Masking Plate for BT-3, inside/outside plates w/bolts

Optimount

Our OptiMount Suspension System attaches to the tom's tension rods and floats on rubber cushions, providing the ultimate in stability while allowing the drum to resonate fully without restriction. With OptiMount, the mounting hardware is completely removed from the drum shell, providing a drastic improvement in resonance and sustain.



OPT-0708 for drums 7"-8" deep, 8"-16" diameter, UltraGrip Wingnut
OPT-0910 for drums 9"-10" deep, 8"-16" diameter, UltraGrip Wingnut
OPT-1112 for drums 11"-12" deep, 8"-16" diameter, UltraGrip Wingnut
OPT-1314 for drums 13"-14" deep, 8"-16" diameter, UltraGrip Wingnut
OPT-1516 for drums 15"-16" deep, 8"-16" diameter, UltraGrip Wingnut

I.S.S.

Our standard I.S.S. mounts also remove all mounting hardware from the shell and clamp to the rim providing the quickest, easiest mounting system available today. (U.S. PAT. 5544561)



IS-0810N/C fits 8"-10" 1.6mm/Original Superhoops, UltraGrip Wingnut
IS-1216N/C fits 12"-16" 1.6mm, UltraGrip Wingnut
IS-0810SL/C fits 8"-10" 2mm Steel/Stainless Steel & Superhoop II, UltraGrip Wingnut
IS-1216SL/C fits 12"-16" 2mm Steel/Stainless Steel & Superhoop II, UltraGrip Wingnut

Floor Tom Legs



LG-40/3 FT Legs w/Air Suspension Feet, 3/8" dia (3)
LG-07/3 FT Legs for LB-15/07 (3)

Floor Tom Brackets



LB-40 Floor Tom Leg Bracket Masters
LB-15 Floor Tom Leg Bracket Export
LB-07 Floor Tom Leg Bracket Forum

Floor Tom Rubber Tips



R-40/3 Air Suspension Feet, fits 3/8" Dia Legs (3)
R-5/3 FT Feet for LG-07, fits 3/8" dia Legs (3)

Bass Drum Bracket

The BB-3 accepts all tom holders and accessories using 7/8" tubing. The BB-3's dual brackets feature slip resistant nylon sleeves and fit SX-2 Stop-Locks.



BB-3 Twin 7/8" Receivers, UltraGrip Wingnuts

Bass Drum Hoops



Masters Maple Bass Drum Hoops, Lacquered Finish / Covered Finish
24" RIM-24W for MMX/MRX MSXRIM-24 for MSX
22" RIM-22W for MMX/MRX MSXRIM-22 for MSX
20" RIM-20W for MMX/MRX MSXRIM-20 for MSX
18" RIM-18W for MMX/MRX MSXRIM-18 for MSX

Masters Birch Bass Drum Hoops, Lacquered Finish
24" BRXRIM-24 for BRX
22" BRXRIM-22 for BRX
20" BRXRIM-20 for BRX
18" BRXRIM-18 for BRX

Export Bass Drum Hoops
24" ELXRIM-24 for ELX EXRRIM-24 for ERX EXRIM-24 for EX
22" ELXRIM-22 for ELX EXRRIM-22 for ERX EXRIM-22 for EX
20" ELXRIM-20 for ELX EXRRIM-20 for ERX EXRIM-20 for EX
18" ELXRIM-18 for ELX EXRRIM-18 for ERX EXRIM-18 for EX

Forum Bass Drum Hoops
22" RIM-22RB for FX
20" RIM-20RB for FX

Bass Drum Hoop Protector

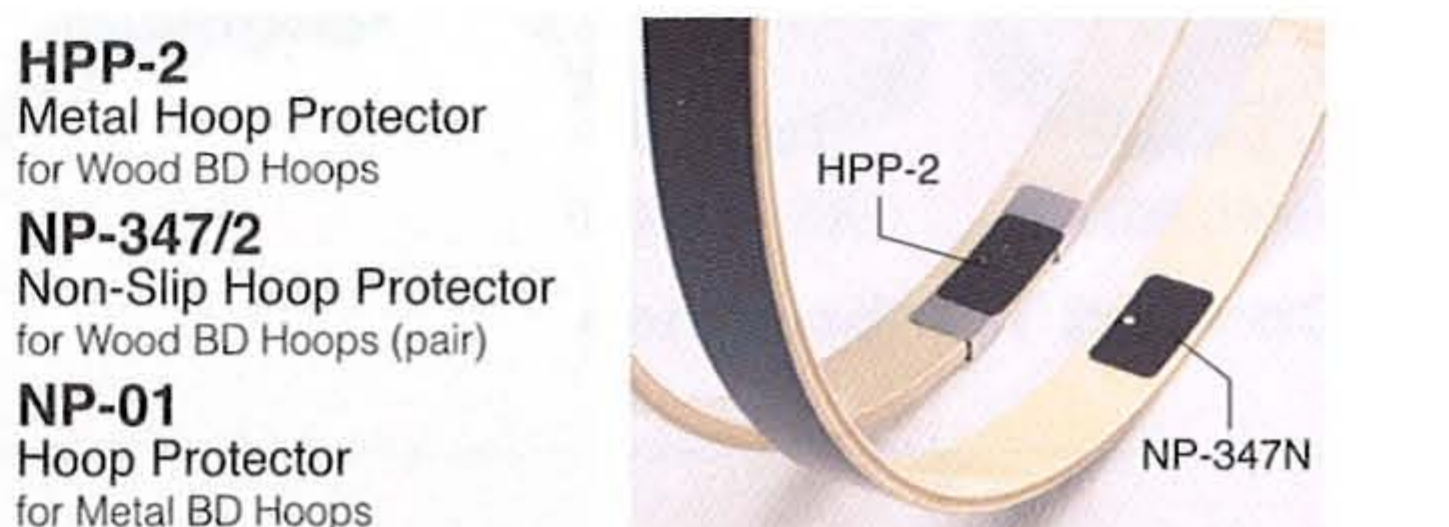

HPP-2 Metal Hoop Protector for Wood BD Hoops
NP-347/2 Non-Slip Hoop Protector for Wood BD Hoops (pair)
NP-01 Hoop Protector for Metal BD Hoops

Bass Drum Spurs



SP-30/2 BD Spurs (pair) New Wingbolts
SP-20/2 BD Spurs (pair) New Wingbolts/Wingnuts

Bass Drum Spurs Rubber Tips



R-30A/2 Rubber Tips for SP-30 (pair)
RHS-1R/2 Rubber Tips for SP-20 (pair)

Bass Drum Tension Rods & Claw Hooks



SST-6115 M6 x 115mm (1) Stainless Steel for Bass Drums
T-065 M6 x 90mm (1) for SMX/SBX/ELX/EXR/EX Bass Drums
T-066 M6 x 110mm (1) for Bass Drums
D-054 Claw Recessed Die Cast, Rubber Gasket, for 1.5" Wide Hoops
CW-80 Claw Export
CW-07 Claw Forum

Die Cast Hoops

MasterCast are the finest die cast hoops available and feature the perfect blend of thickness and mass to improve the depth, clarity, and focus of toms and snare drums.



Model #	Diameter	# of Tension
DC-0805	8"	5
DC-1006	10"	6
DC-1206	12"	6
DC-1306	13"	6
DC-1408	14"	8
DC-1408S	14"	8 Snare Side
DC-1410	14"	10
DC-1410S	14"	10 Snare Side
DC-1410SG	14"	10 Snare Side w/Guard
DC-1508	15"	8
DC-1608	16"	8
DC-1808	18"	8

Super Hoop II

SuperHoop II are precision formed from heavy-duty 2.3mm steel, triple-flanged and engraved with the SuperHoop II logo.



Model #	Diameter	# of Tension
SH-0604	6"	4
SH-0805	8"	5
SH-1006	10"	6
SH-1206	12"	6
SH-1306	13"	6
SH-1408	14"	8
SH-1410B	14"	10
SH-1410S	14"	10 Snare Side
SH-1410SG	14"	10 Snare Side w/Guard
SH-1508	15"	8
SH-1608	16"	8
SH-1808	18"	8

Steel Hoops



Model #	Diameter	# of Tension
RIM-0604	6"	4
RIM-0804	8"	4
RIM-0805	8"	5
RIM-1006	10"	6
RIM-1006SL	10"	6 Snare Side
RIM-1206	12"	6
RIM-1206SL	12"	6 Snare Side
RIM-1208B	12"	8
RIM-1208S	12"	8 Snare Side
RIM-1306	13"	6
RIM-1308B	13"	8
RIM-1308S	13"	8 Snare Side
RIM-1406	14"	6
RIM-1408B	14"	8
RIM-1408S	14"	8 Snare Side
RIM-1410B	14"	10
RIM-1410S	14"	10 Snare Side
RIM-1410SG	14"	10 Snare Side w/Guard
RIM-1508	15"	8
RIM-1606	16"	6
RIM-1608	16"	8
RIM-1808	18"	8

Boom / Cymbal Stand Parts



WL-200 WingLoc Quick Release Wingnut for 8mm Thread
M-8W/2 Wing Nut for Tilter (2)
FL-90/2 Cymbal Felt Large (2)
NP-69/2 Plastic Sleeve (2)
PR-135 Steel Cup Washer
RC-20 Reversible Seat Cup w/O-Ring

Wing Bolts & Wing Nuts



UGB-610/2 Wing Bolt M6 x 10mm (2) New Shape
UGB-815/2 Wing Bolt M8 x 15mm (2) New Shape
UGB-820/2 Wing Bolt M8 x 20mm (2) New Shape
UGN-6/2 Wing Nut M6 (2) New Shape
UGN-8/2 Wing Nut M8 (2) New Shape
UGN-8L Wing Nut M8 Large Handle, New Shape
M-8RN/2 Knurled Round Nut M8 (2)

Rubber Tips

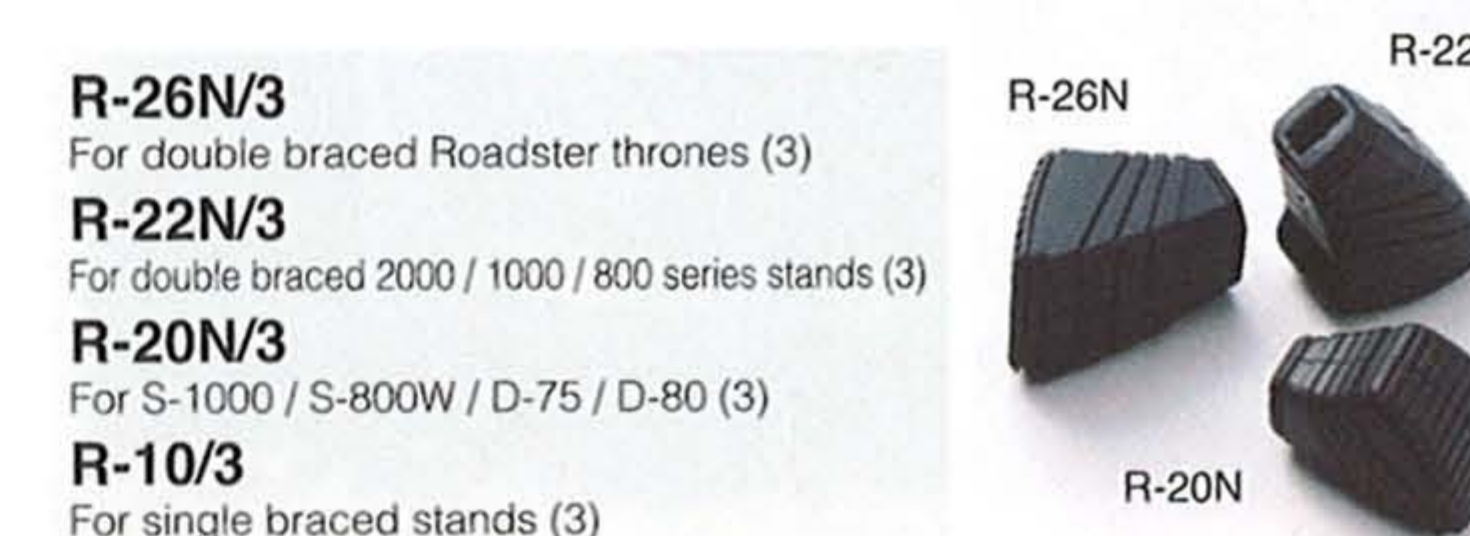

R-26N/3 For double braced Roadster thrones (3)
R-22N/3 For double braced 2000 / 1000 / 800 series stands (3)
R-20N/3 For S-1000 / S-800W / D-75 / D-80 (3)
R-10/3 For single braced stands (3)

Aluminum Drive Shaft

The DS-200A Drive Shaft is standard on all Pearl double pedals and features heavy-duty ultra-precise stainless steel universal joints for accurate and lag-free performance.



DS-200A Drive Shaft Assy Complete

Key Bolts

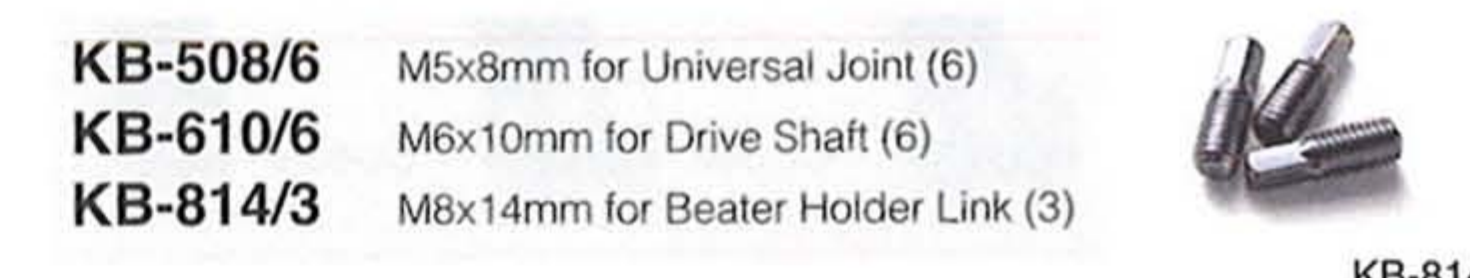

KB-508/6 M5x8mm for Universal Joint (6)
KB-610/6 M6x10mm for Drive Shaft (6)
KB-814/3 M8x14mm for Beater Holder Link (3)

Chains & Belts



CCA-1 Chain Assy Complete for 100 Series Power Shifter/PowerPro
CCA-10 Chain Assy Complete for 1000 Series
CCA-5 Chain Assy Complete for Eliminator Pedals
BCA-1 Belt Assy Complete for Eliminator Pedals
BCA-10 Belt Assy Complete for 1000 Series
ME-255A Chain Assy Complete for P-201P

Cams, Beater Weight & Spring

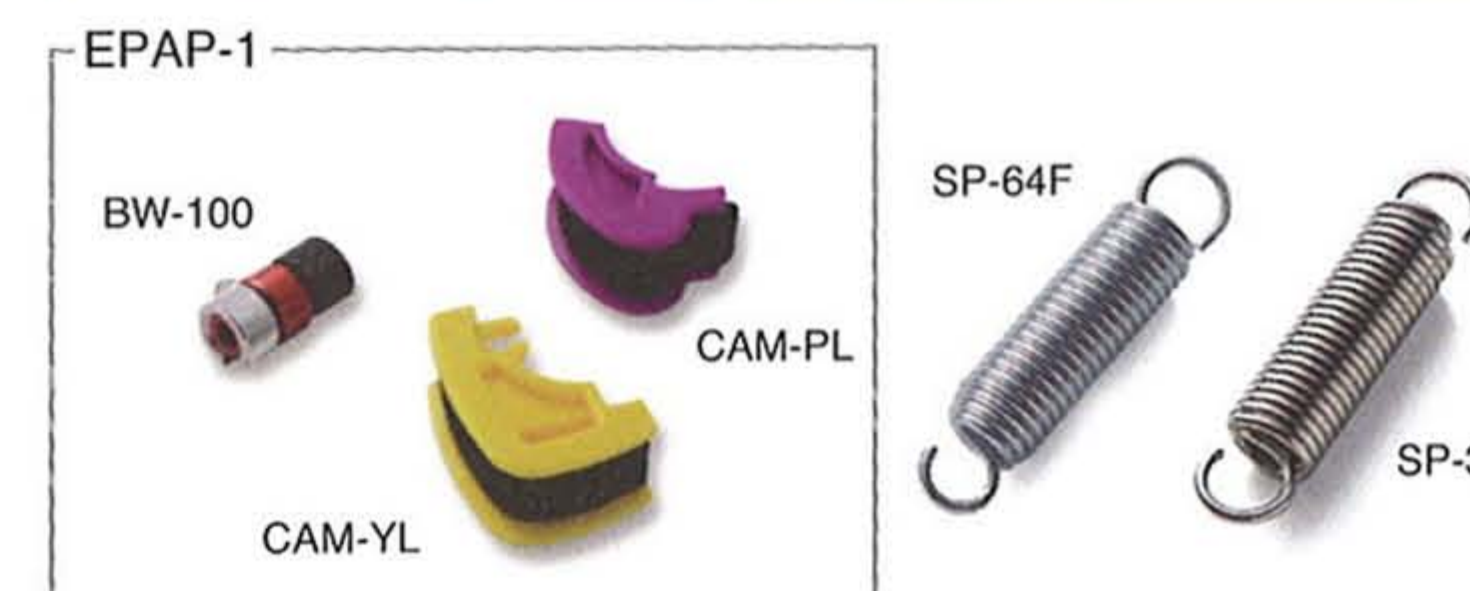

EPAP-1 Package: Beater Weight, Purple Cam, Yellow Cam
BW-100 Eliminator Purple Cam, Aggressive Action
CAM-PL Eliminator Yellow Cam, Inverse Action
CAM-YL Eliminator Black Cam, Linear Action
SP-64F Eliminator White Cam, Oversized Linear Action
SP-31F Eliminator Blue Cam, Progressive Action
SP-64F Eliminator Red Cam, Radical Action
SP-64F Beater Weight, 3 Weights in One
SP-31F Spring w/Felt for P-120
SP-64F Spring w/Felt for Eliminator / P-1000 / P-120P Pedals

Replacement Parts

Hi-Hat Clutches



- DCL-300P** Drop Clutch, Rubber Washers, New Lock Nut
- SGC-300P** Super Grip Clutch, Rubber Washers, New Lock Nut
- CL-300** Clutch, Triple-Lock, Felt Washers, New Lock Nut
- CL-68N** Clutch, Standard, Felt Washers

Hi-Hat Upper Section



- NP-208** Cup Washer Rubber, Minimal-Contact
- NP-210/2** Clutch Washers Rubber (pair)
- FE-17** Felt Washer
- FL-95/2** Clutch Washers Felt (pair)
- PR-128** Steel Bottom Washer
- HHC-1** Seat Cup
- ME-145** Pull Rod 7mm Dia
- CCA-3A** Chain Assy w/End Connectors for H-885
- CCA-5H** Chain Assy w/End connectors for H-2000/RH-2000

Stainless Steel Tension Rods

Pearl's Stainless Steel Tension Rods are machined, not forged, from a single piece of stainless steel to the most exacting tolerances in the industry. They feature super-smooth, precise tensioning, with absolutely no play. Each non-plated stainless steel tension rod is matched with a precision-machined brass swivel nut for ultra-precise performance.

- SST-5028/6** M5.8 x 28mm (6)
- SST-5035/6** M5.8 x 35mm (6)
- SST-5042/6** M5.8 x 42mm (6)
- SST-5047/6** M5.8 x 47mm (6)
- SST-5052/6** M5.8 x 52mm (6)



TensionRods/Washers/LockNuts



- T-055/6** M5.8 x 28mm (6)
- T-060/6** M5.8 x 35mm (6)
- T-061/6** M5.8 x 42mm (6)
- T-061L/6** M5.8 x 47mm (6)
- T-062/6** M5.8 x 52mm (6)
- T-062L/6** M5.8 x 57mm (6)
- T-063L/6** M5.8 x 67mm (6)
- NLW-12/12** Nylon Washers (12) White
- NLW-12B/12** Nylon Washers (12) Black
- MTW-12/12** Metal Washers (12)

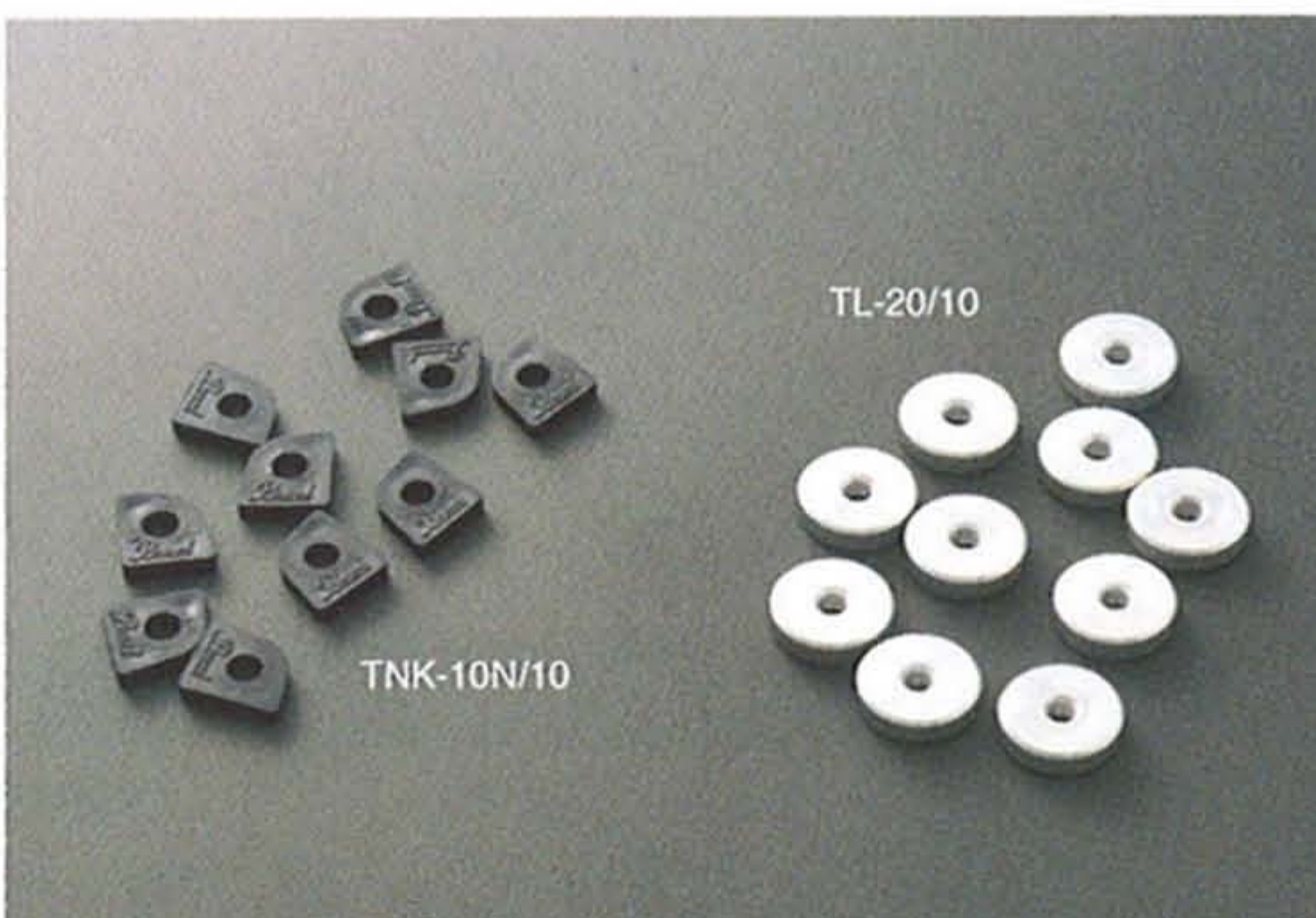

- S-61/12** Swivel Nut, M5.8 (12)
- S-71/12** Swivel Nut, M6 (12)
- DC-5BN-2/12** Swivel Nut, M6 (12) for Stainless Steel Tension Bolt
- DC-6BN-2/12** Swivel Nut, M5.8 (12) for Stainless Steel Tension Bolt
- TL-20/10** Tension Rod Lock Nuts (10/pkg)
- TNK-10N/10** Tension Keeper (10/pkg)

Lugs



- CL-250** Masters Bridge Lug for Bass Drums
- CL-100** Masters Bridge Lug for Tom/Snare Drums
- CL-65** Masters Bridge Lug for 6.5" depth
- CL-55** Masters Bridge Lug for 5.5" depth
- CL-05** Lug for Piccolo Snare Drums
- NCL-200** Bridge Lug for SMX/SBX/ELX/EXR/EX Bass Drums
- NCL-100** Bridge Lug for SMX/SBX/ELX/EXR/EX Toms
- NCL-55** Bridge Lug for SMX/SBX/ELX/EXR/EX Snare Drums
- SL-03** Lug for FX Snare Drum
- SL-02** Lug for FX Bass Drums
- SL-01** Lug for FX Toms
- FT-65** Tension Post for F.F.S. Snare Drum, 6.5" depth
- FT-50** Tension Post for F.F.S. Snare Drum, 5" depth
- FT-35** Tension Post for F.F.S. Snare Drum, 3.5" depth
- TB-65** Tube Lug for 6.5" depth Snare Drums
- TB-55** Tube Lug for 5.5" depth Snare Drums
- TB-50** Tube Lug for 5" depth Snare Drums

Muffler

External clamp-on muffler for snare drums and toms. By adjusting the pressure and position of the felt pad, excessive overtones can be precisely controlled or eliminated.

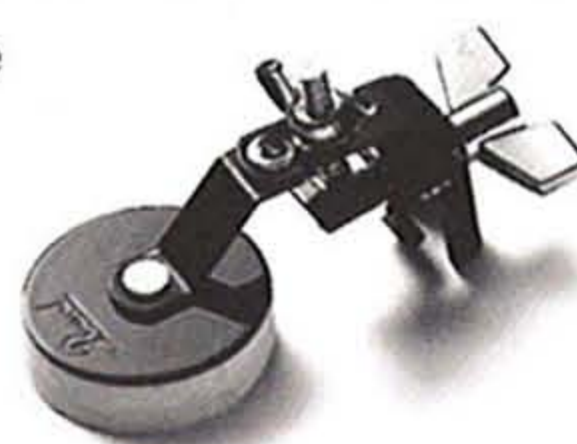

- OM-1** Clamp-on Muffler, Snare Drum & Toms

Practice Pads

Bass Drum Pedal Training Pad

BD-10
The BD-10 bass pad is perfect for practicing at home or on the road. The wide pad accommodates double pedals and is specially formulated for extremely low noise and a realistic feel. The universal-fit "hoop" accepts all brands of pedals and adjusts to compensate for different floor surfaces. The BD-10 folds for compact transport.



Training Drum Pad

SD-50

The SD-50 features Pearl's unique rubber pad surface with realistic rebound and near silent performance. The stand and pad use heavy-duty 8mm threading for superior durability and stability.

Silencer Rubber Pads



RP-50
Our RP-50 features five rubber discs for silent practicing on drumsets with 12", 13", and 16" toms, and 14" snare drum. A universal-fit bass pad with adjustable straps is also included. They remove easily for resumption of live play.

RP-40C
Our RP-40C Cymbal Silencers effectively reduce the volume of cymbals for practicing. The set includes two 18" /20" cymbal pads and a pair for 14" hi-hats.

Pearl Drum Heads

Pearl's exclusive ProTone heads standard equipment on Session, Export, and Forum are specially designed to deliver maximum performance and durability. They're affordably priced and available separately in a wide range of models to satisfy virtually any playing style.

Bass Drum Heads

ProTone bass drum heads feature built-in Perimeter EQ rings that provide "out-of-the-box" playability with little or no additional muffling. ProTone batter heads are available in coated and clear single-ply and clear two-ply

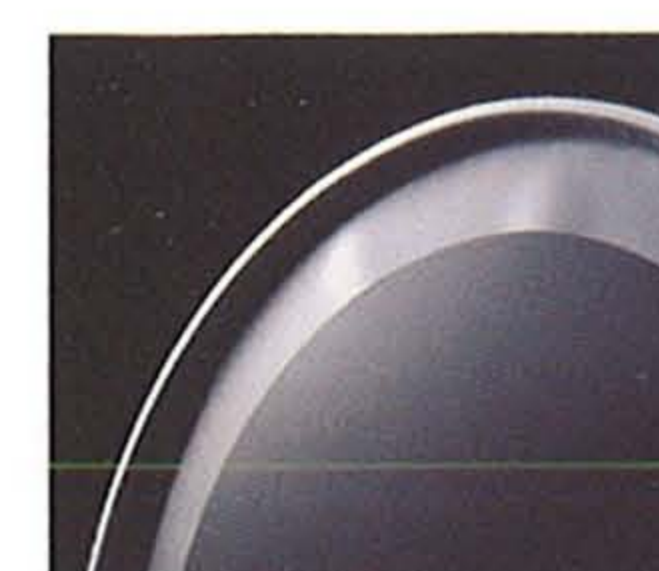

versions. ProTone resonator heads feature the Pearl logo and are available in Coated and Ebony (black). The Black Beat head is similar to the ProTone Ebony but without the Perimeter EQ system.



Bass Drum - Front Heads w/LOGO

Size	ProTone EBONY w/Perimeter EQ	Size	ProTone COATED w/Perimeter EQ	Size	BLACK BEAT
18"	PTH-18PL	18"	PTH-18CEQPL	18"	EB-18BDPL
20"	PTH-20PL	20"	PTH-20CEQPL	20"	EB-20BDPL
22"	PTH-22PL	22"	PTH-22CEQPL	22"	EB-22BDPL
24"	PTH-24PL	24"	PTH-24CEQPL	24"	EB-24BDPL

Bass Drum - Batter Heads

Size	ProTone CLEAR w/Perimeter EQ	ProTone COATED w/Perimeter EQ	ProTone CLEAR Double Ply
18"	PTH-18EQ	PTH-18CEQ	---
20"	PTH-20EQ	PTH-20CEQ	PTH-20D
22"	PTH-22EQ	PTH-22CEQ	PTH-22D
24"	PTH-24EQ	PTH-24CEQ	PTH-24D

Tom Heads

ProTone tom heads are made with a proprietary film specially designed for drumheads for outstanding tone and durability. Whether you like the quick attack of single-ply heads or the wetter, fatter sound of two-ply heads, ProTone has you covered. ProTone tom heads are available in coated and clear single-ply and clear two-ply versions.

Pro Tone Tom Heads

Size	COATED-Single Ply	CLEAR-Single Ply	CLEAR-2PLY
8"	PTH-08C	PTH-08	PTH-08D
10"	PTH-10C	PTH-10	PTH-10D
12"	PTH-12C	PTH-12	PTH-12D
13"	PTH-13C	PTH-13	PTH-13D
14"	PTH-14C	PTH-14	PTH-14D
15"	PTH-15C	PTH-15	PTH-15D
16"	PTH-16C	PTH-16	PTH-16D
18"	PTH-18C	PTH-18	PTH-18D



COATED-Single Ply

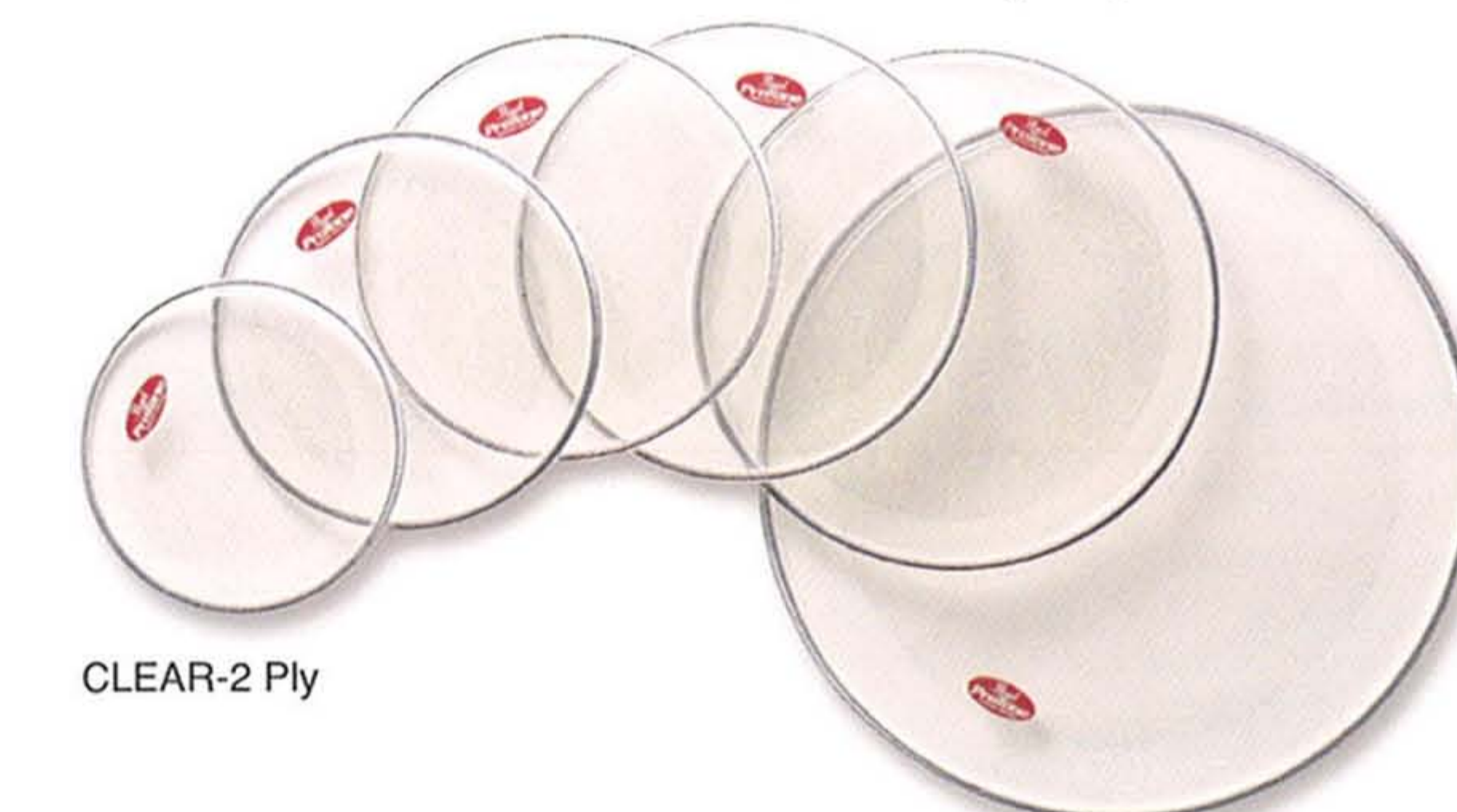

CLEAR-2 Ply



CLEAR-Single Ply

Snare Drum Heads

Pearl snare side heads feature excellent stretch resistance for long wear and outstanding sensitivity.

Snare Drum Heads

Size	SNARE SIDE
13"	SS-13S
14"	SS-14S

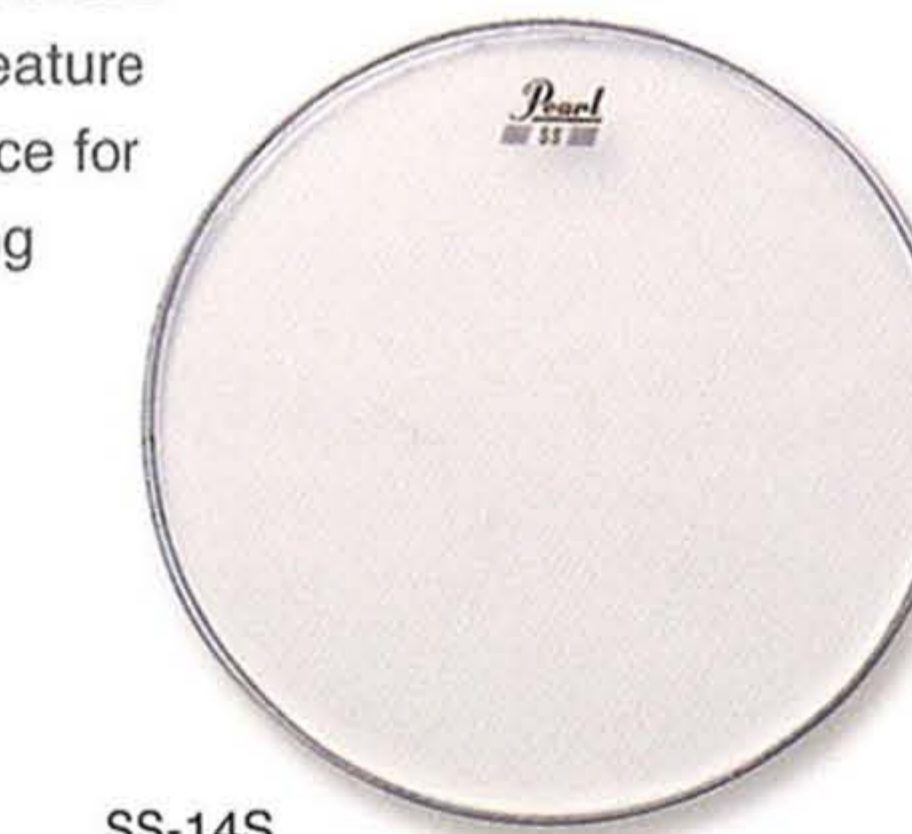

SS-14S

Muffle Heads

Muffle Heads are made with a high-strength woven material that allows air to escape for dramatically reduced volume. Most any acoustic kit can be converted to a 24/7 practice kit by simply switching the batter heads to Muffle Heads.

Muffle Heads

Size	Model #	Size	Model #
8"	MFH-08	14"	MFH-14
10"	MFH-10	16"	MFH-16
12"	MFH-12	20"	MFH-20B
13"	MFH-13	22"	MFH-22B

