

# PEARL DRUM PEDAL

## P-3002C

### P-3002CL / P-3001C



#### Instruction Manual

Congratulations on your purchase!  
For optimum performance, please read this Instruction Manual before playing.

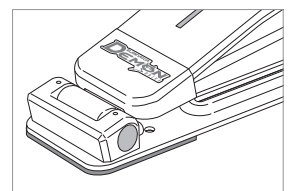
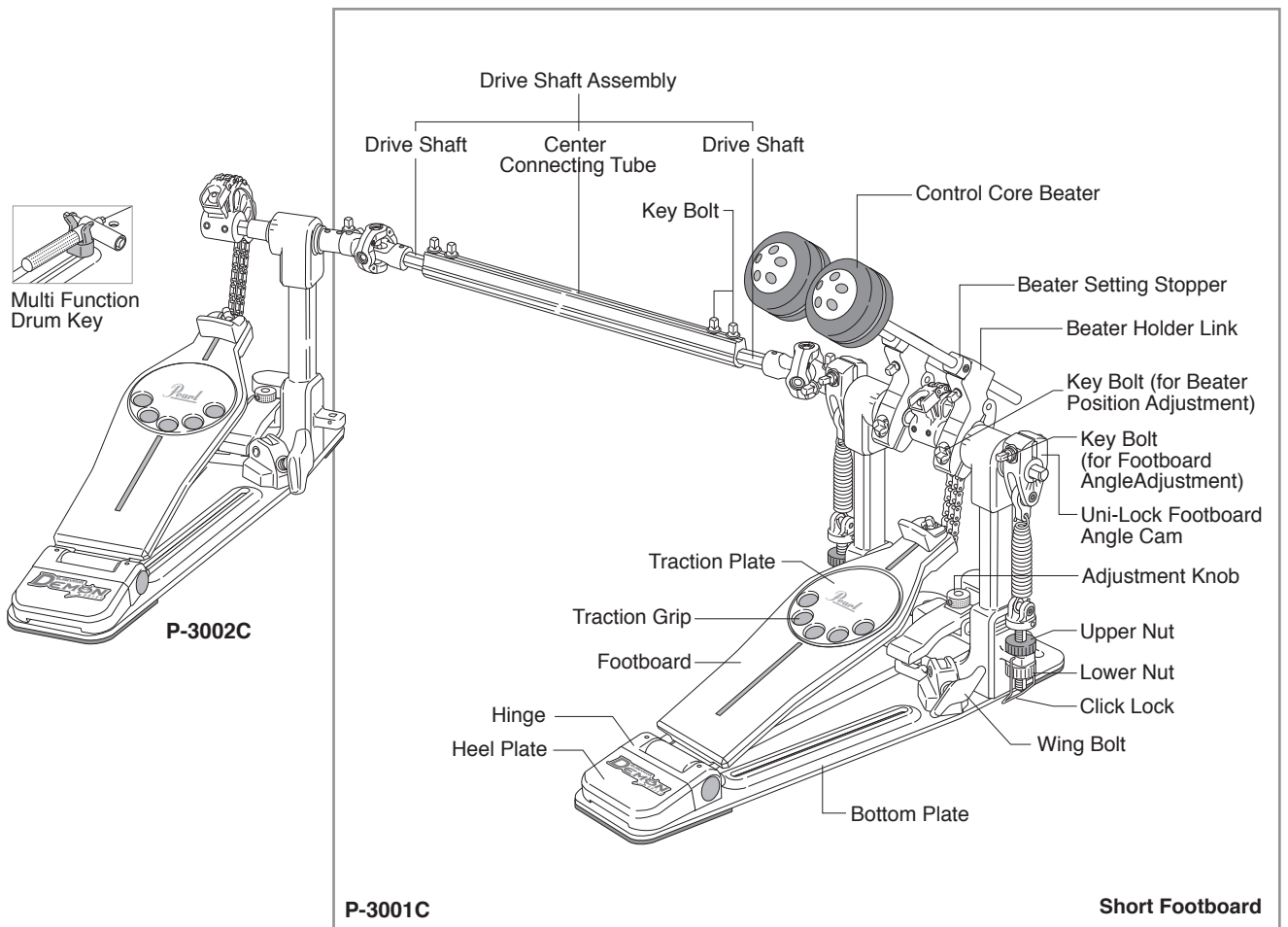

**Long Footboard**

#### Included Items

NiJiA Oil, Velcro Tape (x6), Allen Wrench (3mm, 2.5mm)

## Control Core Beater Setting

Insert the Control Core Beater into the Beater Holder Link until it stops against the Beater Setting Stopper, and tighten the Key Bolt with the provided Multi Function Drum Key (Fig.1-A). Make sure that the Beater Setting Stopper is flush against the Beater Holder Link with the flat face square against the Notch (Fig.1-B).

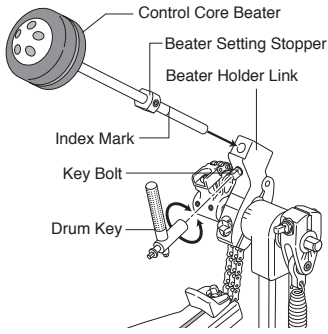

Fig.1-A

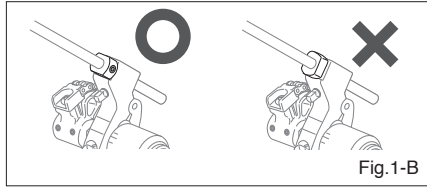

Fig.1-B

### Tip

In the initial factory setting, the Index Mark is centered in the Window as shown (Fig. 2)

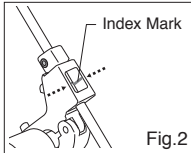

Fig.2

To change to a higher or shorter beater height, loosen the Allen Screw on the Beater Setting Stopper with the provided Multi-Function Drum Key or Allen wrench (3mm) then loosen the Key Bolt on the Beater Holder Link (Fig. 3). Set the beater to the desired height and re-tighten the Key Bolt. Reset the Beater Setting Stopper flush against the Beater Holder Link per the instructions above.

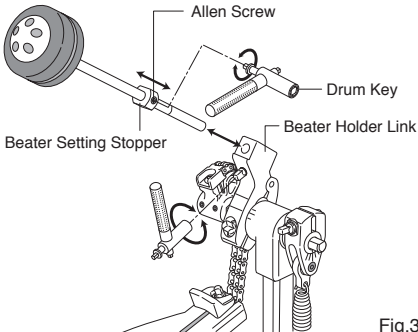

Fig.3

### Tip

The Beater Setting Stopper preserves the height setting if the beater is removed when transporting the pedal.

## Beater Stroke Adjustment

The P-3002C Demon Chain Double Pedal features Pearl's patented two-position Beater Holder that can be positioned closer or farther from the drum head for Finesse "A" Position setting or Power "B" Position setting respectively.

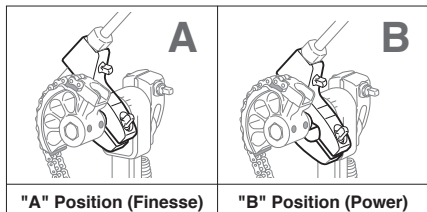

"A" Position (Finesse)

"B" Position (Power)

It also rotates infinitely for perfect beater angle without changing the footboard angle.

### Tip

The Beater Holder is set at the factory in the Finesse "A" Position.

## Changing the Beater Holder Position

To change to the Power setting, loosen the Key Bolt to open the clamp and slide the Beater Holder to the Power setting position (Fig.4-A, 4-B). There is no need to remove the Key Bolt from the clamp.

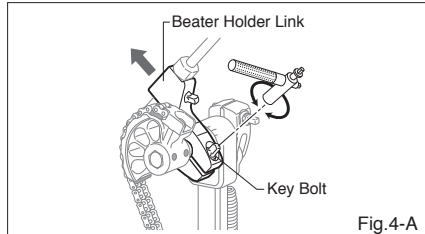

Fig.4-A

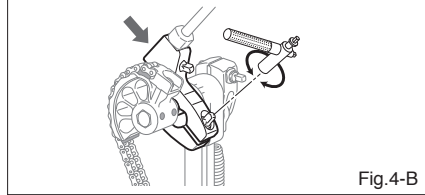

Fig.4-B

## Beater Angle Adjustment

To change the angle of the Beater, loosen the Key Bolt and set the angle to your preference and re-tighten the Key Bolt (Fig.5).

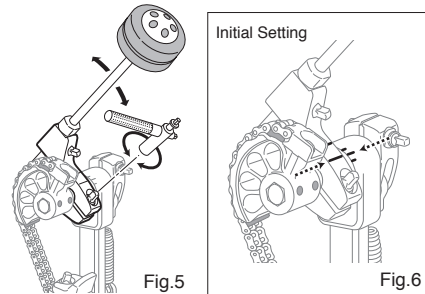

Fig.5

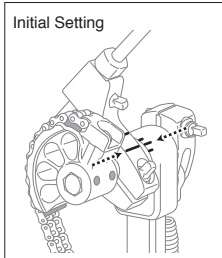

Fig.6

### Tip

Indicator marks are provided for referencing Beater angle settings (Fig.6).

### Tip

If the Beater is too far from the Bass Drum Head, the Footboard can touch the Hoop Clamp and cause damage to the Footboard and/or the Hoop Clamp. To prevent damage, please refer to (Fig.7), and adjust the Beater angle as shown.

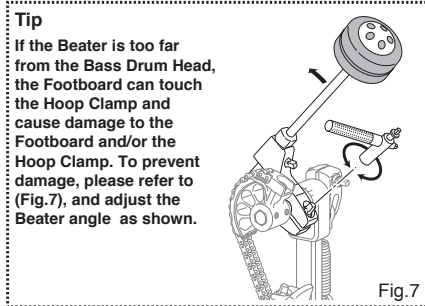

Fig.7

## Footboard Angle Adjustment

The Footboard Angle can be adjusted by loosening the Key Bolt on the Uni-Lock Footboard Angle Cam and adjusting it to the desired angle (Fig.8-A). Re-tighten the Key Bolt to secure the angle. A gauge on the side of the Angle Cam is provided to reference Footboard Angle settings (Fig.8-B).

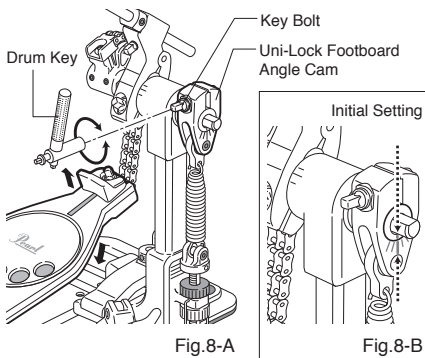

Fig.8-A

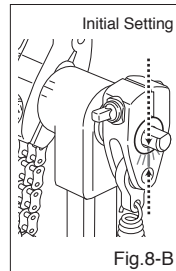
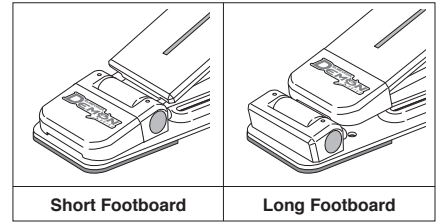

Fig.8-B

## Duo-Deck Footboard

The P-3002C features Pearl's patented Duo-Deck Footboard, the world's first convertible Short / Long Footboard.



Short Footboard

Long Footboard

### Tip

The Duo-Deck is set at the factory in the Short Footboard setting.

To convert the Duo-Deck to a Long Footboard, turn the pedal over and remove the four Flat Head Screws with the provided Multi-Function Drum Key or Allen wrench (3mm) as shown and remove the Heel Plate and the Hinge from the Bottom Plate (Fig.9).

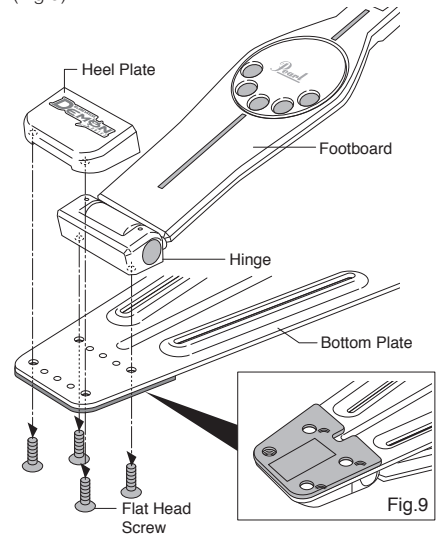

Fig.9

Lift the Footboard and remove the four 3-Piece Screws with the provided Multi-Function Drum Key or Allen wrench (3mm) as shown, and remove the Hinge from the Footboard (Fig.10).

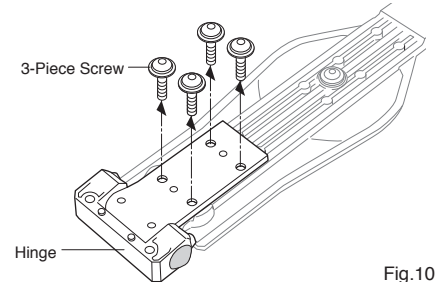

Fig.10

Reattach the Hinge to the Footboard in the position shown with two 3-Piece Screws using the provided Multi-Function Drum Key or Allen wrench (3mm) (Fig.11).

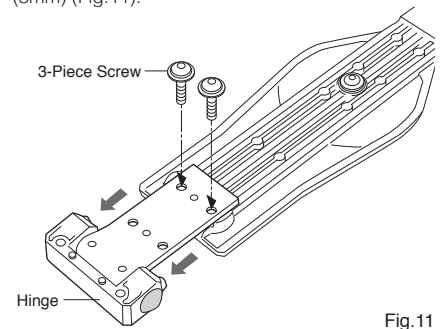

Fig.11

Place the Heel Plate between the Footboard and the Hinge (Fig.12) and attach the Heel Plate with the remaining two 3-Piece Screws using the Multi-Function Drum Key or Allen wrench (3mm). Attach the Hinge to the Bottom Plate with two Flat Head Screws using the Multi-Function Drum Key or Allen wrench (3mm) (Fig.12). The Hinge is now located at the back of the Footboard to achieve a Long Footboard.

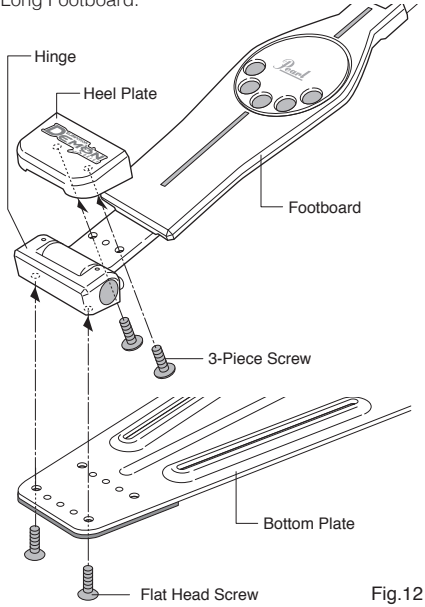

Fig.12

**Tip**  
The Duo-Deck Footboard uses two different types of screws. Make sure to use the correct screws.

Flat Head Screw      3-Piece Screw

### Connecting the Drive Shaft Assembly

Connect the ends of the Drive Shaft (A) to the short extensions (B) on the Main and Slave Side Pedals and tighten Key Bolt 1 and then Key Bolt 2 (Fig.13 ,14).

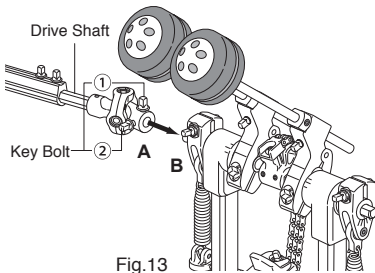

Fig.13

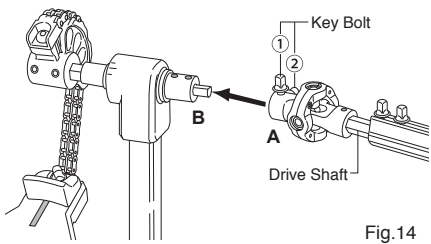

Fig.14

**Tip**  
Tip : You may need to rotate the Drive Shaft Assembly to bring the footboard of the Slave Side (left) Pedal to the proper playing height (angle) before attaching the Drive Shaft Joints (A) to both pedals.

Loosen the Key Bolts on the Center Connecting Tube of the Drive Shaft Assembly and adjust the distance between the Main Pedal and the Slave Side Pedal to your liking. Re-tighten the Key Bolts (Fig.15-A).

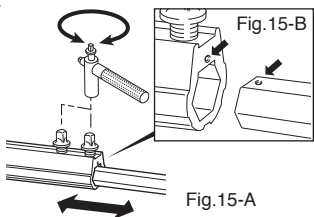

Fig.15-A

**Tip**  
If the Drive Shafts are extended too far, they will separate from the Center Connecting Tube. Reassemble them with the dots aligned as shown in Fig.15-B.

### Spring Tension Adjustment

The P-3002C Demon Chain Double Pedal features our patented Click Lock spring tension retention system. To increase the spring tension, disable the Click Lock by lifting the lever upward, loosen the Upper Nut and tighten the Lower Nut until the desired tension is achieved (Fig.16-A). To decrease spring tension, disable the Click Lock by lifting the lever upward, loosen the Upper Nut and loosen the Lower Nut until the desired tension is achieved. When the desired spring tension is achieved, tighten the Upper Nut to keep the spring tension from loosening then press the Click Lock lever down to engage the grooves around the Lower Nut until you feel the lever "Click" (Fig.16-B). Before playing, make sure that both Upper and Lower Nuts are tight and the Click Lock lever is in a vertical position with both sides of the lever engaged in the grooves around the Lower Nut.

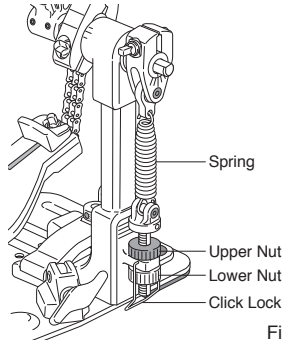

Fig.16-A

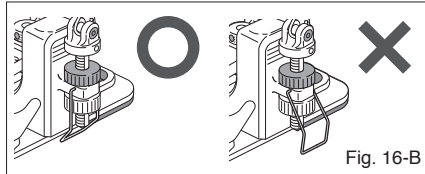

Fig. 16-B

### Traction Plate / Traction Dots

The Traction Plate adjusts to a variety of grip/slide configurations. To change the position of the Traction Dots, use the Multi-Function Drum Key or Allen wrench (3mm) to remove the 3-Piece Screw beneath the footboard and remove the Traction Plate (Fig.19). Rearrange the Traction Dots to your preference and replace the Traction Plate.

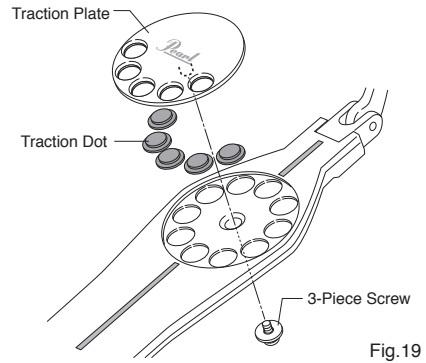
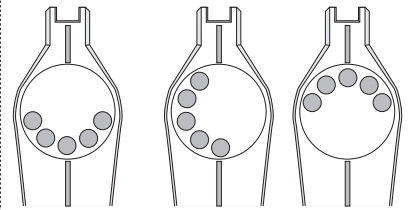

Fig.19

#### Tip Setting Examples



The Aluminum Traction Dots can be replaced with optional NP-283N/7 Rubber Dots for more traction.

### Hoop Clamp System

The P-3002C Hoop Clamp System is designed with Spherical Rubber Grips allowing the front of the bass drum to be raised while keeping the pedal flush on the floor. Insert the bass drum hoop into the Clamp, and turn the Wing Bolt to secure.

The Clamp comes preset from the factory to accommodate most bass drum hoops but if necessary it can be adjusted to fit thicker or thinner hoops. Loosen the Allen Screw on the Adjustment Knob with the provided Allen wrench (2.5mm) as shown and tighten or loosen the Adjustment Knob until proper fit is achieved then re-tighten the Allen Screw (Fig.17). If the heel plate of the pedal lifts while playing, try loosening the Adjustment Knob to change the angle of the Hoop Clamp until the pedal remains flat.

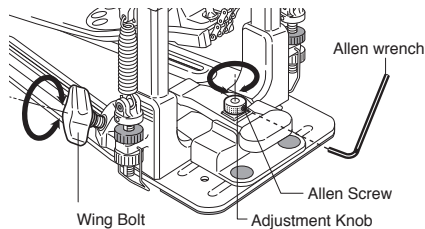

Fig.17

### Velcro Strips for Slip Prevention

Velcro Strips are provided with P-3002C Double Pedals to help prevent slipping when used on carpeted floors. To apply, peel off the backing on the Velcro Strips and apply them in the locations shown. Clean the surfaces thoroughly with alcohol and dry completely for best adhesion (Fig.18).

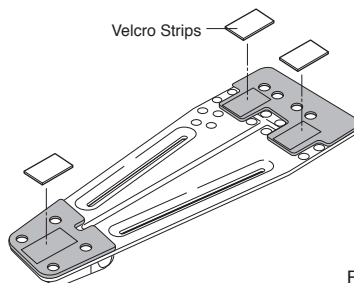
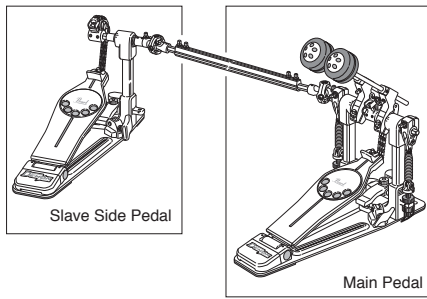

Fig.18

## Modular Post System

The P-3002C features Pearl's Modular Post System that allows easy conversion from a Double Pedal to two Single Pedals.



## • Converting the Main Pedal

To convert the Main Pedal to a Single Pedal, turn the pedal over and remove the two Flat Head Screws with the provided Multi-Function Drum Key or Allen wrench (3mm) and detach the Hoop Clamp (Fig.20).

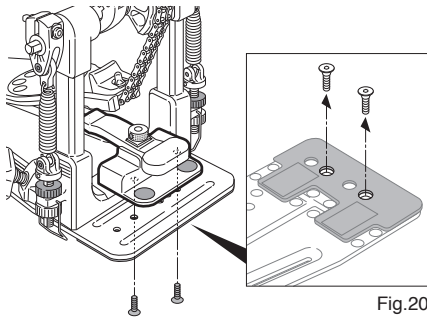

Remove the four Flat Head Screws under the Left Post with the provided Multi-Function Drum Key or Allen wrench (3mm), and detach the Left Post (Fig.21).

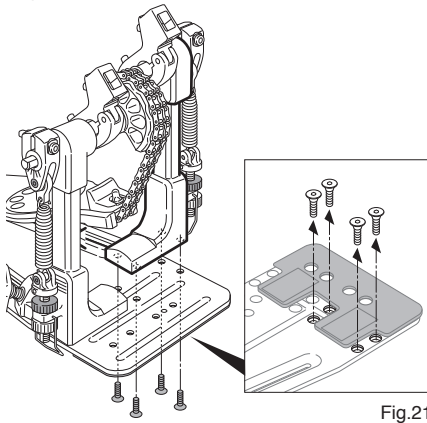

Reattach the Hoop Clamp in the position shown with two Flat Head Screws using the provided Multi-Function Drum Key or Allen wrench (Fig.22). Your Main Pedal is now ready to be used as a Single Pedal.

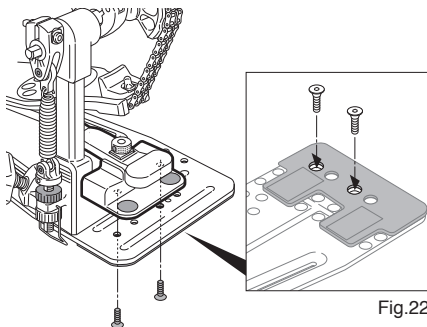

## • Converting the Slave Side Pedal

To change the Slave Side of a P-3002C Double Pedal into a Single Pedal, detach the Spring Assembly and the Beater Holder Link from the Left Post of the P-3002C Double Pedal and transfer them to the Slave Side Pedal.

To detach the Spring Assembly, disengage the Click-Lock (Fig.23-a) and remove the Lower Nut (Fig.23-b) and remove the threaded Bolt from the post. Loosen the Key Bolt (Fig.23-c) and remove the Uni-Lock Footboard Angle Cam from the post (Fig.23-d). Gently spread the Click Lock apart and remove it from the post (Fig.23-e). Use caution to prevent the Click Lock from deforming. To detach the Beater Holder Link, remove the Key Bolt with the Multi-Function Drum Key, open the clamp and remove it from the shaft (Fig.23-f).

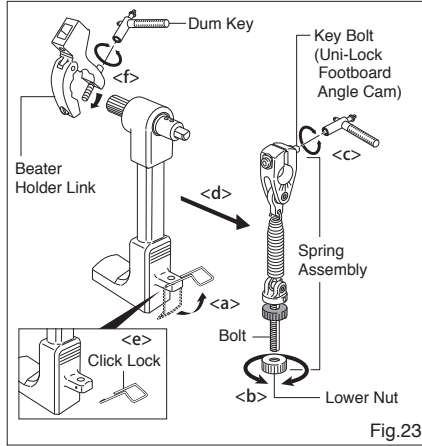

Reverse the previous sequence and attach the Spring Assembly, Beater Holder Link and the Beater to the Slave Side Pedal. Change the position of the Key Bolt as shown on the Uni-Lock Footboard Angle Cam for easier access when making Footboard angle adjustments (Fig.24). Your Slave Side Pedal is now ready to be used as a Single Pedal.

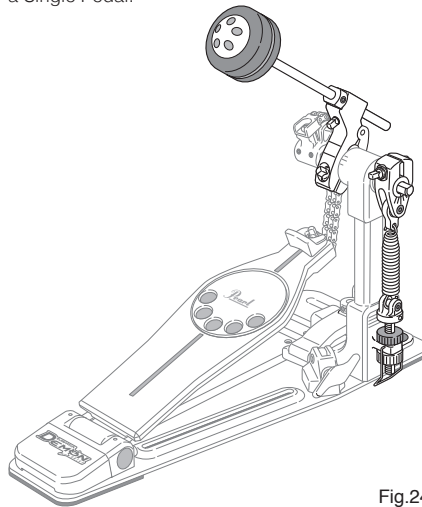

## NiNJA Oil

The P-3002C features precision NiNJA bearings for incredible speed and smoothness. To keep them functioning at their maximum speed and performance it's recommended that you apply genuine NiNJA Oil at regular intervals (Fig.25). NiNJA Oil is also ideal for use on the footboard hinges to maintain "like-new" performance (Fig.26).

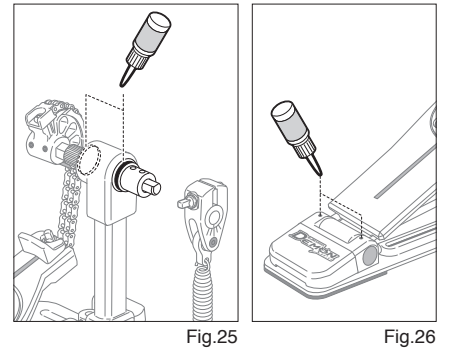

**Note**  
For best results, always use genuine NiNJA Oil.

## Optional Items (sold separately)

- Control Core Wood Beater (B-300W)
- Traction Rubber Grip (NP-283N/7)
- Pedal Stabilizer (PS-300)
- NiNJA Oil (OL-300)

**CAUTION**  
◆ Check all Key Bolts and Allen Screws for tightness before performances, and tighten them with the provided Multi-Function Drum Key or Allen wrenches as needed.



<https://www.pearldrums.com>

Products and specifications are subject to change without notice.

Printed in China  
-Jan 2021-