

PEARL DRUM PEDAL

P-120

Instruction Manual

Congratulations on your purchase!
To get optimum performance of your Pedal,
please read this Instruction Manual before playing.

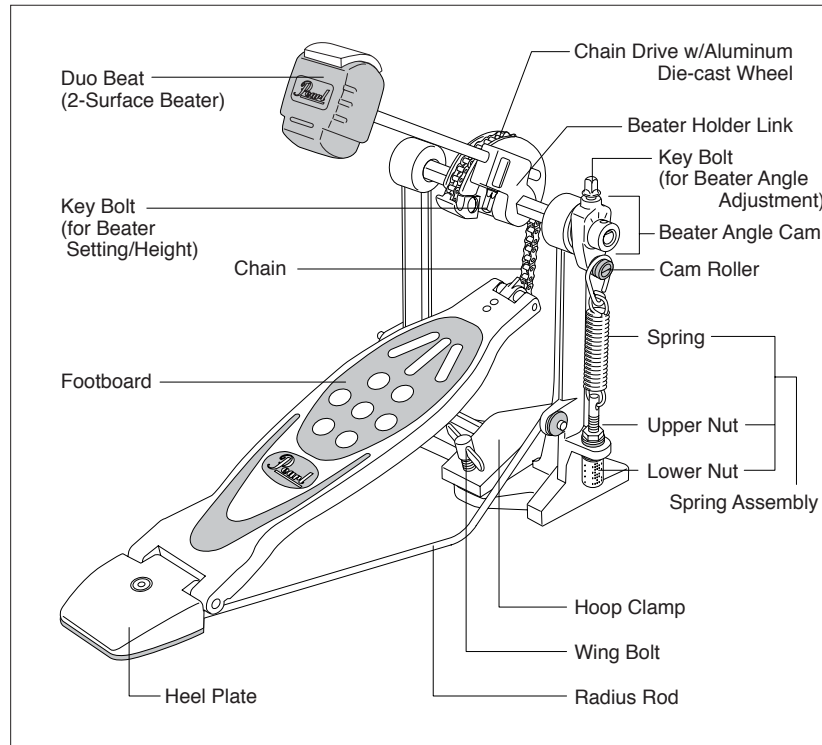

DUO BEAT (2-Surface Beater)

The Duo Beat has two Surfaes, each capable of producing a different sound. Please refer to the following chart to determine the sound best suited your playing style. (Fig. A)

Surface	Surface Material	Contact Area	Sound
<input type="checkbox"/> A	Felt	Line	Warm with Fat Attack
<input type="checkbox"/> B	Plastic	Line	Hard with Fat Attack

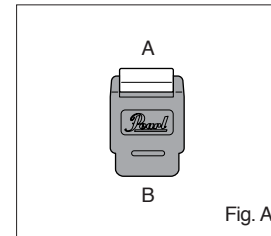

BEATER SETTING

Locate the Beater Holder Link and Key Bolt. Insert the shaft of the Duo Beat into the Beater Holder Link and tighten the Key Bolt to secure the beater at the desired height. Experiment with different beater heights to find the best combination of power and speed. (Fig. B)

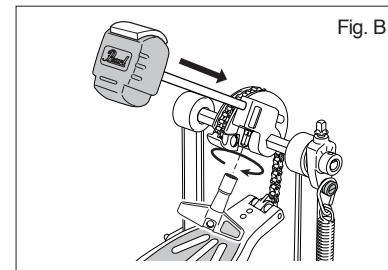

BEATER ANGLE ADJUSTMENT

Depending on your preference, the beater can be positioned closer or further away from the bass drum head. This is accomplished by loosening the Key Bolt on the Beater Angle Cam and swinging the beater to the desired angle. Re-tightening the Key Bolt. (Fig. C)

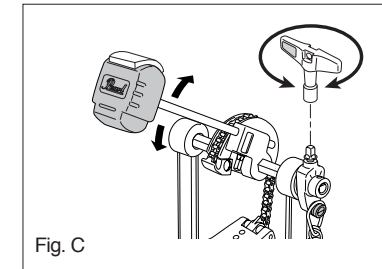

SPRING TENSION ADJUSTMENT

To increase the tension of the spring, loosen the Upper Nut and tighten the Lower Nut until the desired tension is achieved. To decrease the tension, loosen the Lower Nut. This adjustment assembly employs a double nut system to retain tension settings. Before playing, make sure that both nuts are tight. (Fig. D)

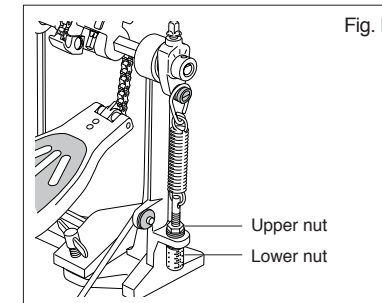

HOOP CLAMP WING BOLT

Place the pedal on the bass drum hoop and tighten the Wing Bolt to clamp the pedal firmly in place. (Fig. E)

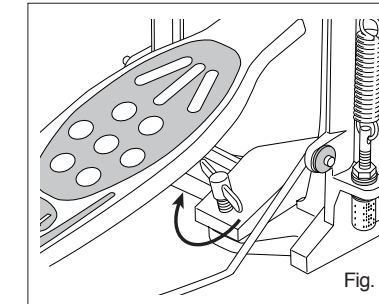

CAUTION

- Periodically check all Allen Screws for tightness and tighten them with the provided Allen Wrenches as needed.
- Periodically apply lube to all moving parts such as the Chain, Cam Roller, Footboard Hinge, etc. for optimal speed and extended life of your pedal. Bearings should be lubricated with grease, not liquid oil.

Pearl

The best reason to play drums.

Products and specifications are subject to change without notice. Printed in Taiwan.