

Available Colors

Lacquer Finishes

MMX MRX MHX BRX SRX ELX EX FX RT

	No.100 Wine Red	●	●		●					
	No.102 Natural Maple	●	●							
	No.103 Piano Black	●	●		●					
	No.112 Natural Birch				●					
	No.122 Black Mist	●	●							
	No.128 Vintage Sunburst				●					
	No.141 Red Mahogany			●						
	No.151 Platinum Mist	●	●		●					
	No.152 Antique Gold	●			●					
	No.153 Sunrise Fade	●	●							
	No.154 Midnight Fade	●	●		●					
	No.156 Purple Storm	●								
	No.160 Silver Sparkle		●							
	No.168 Ocean Sparkle	●								
	No.270 Burgundy Mist							●		
	No.271 Ebony Mist							●		
	No.273 Blue Mist							●		
	No.274 Amber Mist							●		
	No.279 Cobalt Mist							●		
	No.281 Carbon Mist							●		
	No.285 Dusk Blue							●		
	No.288 Burnt Amber							●		
	No.290 Vintage Fade							●		
	No.291 Cranberry Fade							●		
	No.292 Marine Blue Fade							●		
Covered Finishes										
	No.31 Jet Black							●	●	●
	No.33 Pure White							●	●	●
	No.50 Mirror Chrome							●		
	No.55 Silver Flash								●	
	No.91 Red Wine							●	●	
	No.95 Deep Blue							●	●	
	No.98 Charcoal Metallic							●	●	

Colors shown in this catalogue are for representation only and may not exactly be the same as the original colors due to the printing processes involved. Products and specifications are subject to change without notice.

Pearl
The best reason to play drums.

For more information on these or any Pearl product, visit your local authorized Pearl Dealer. You can also visit us on the World Wide Web Site www.pearldrum.com

Printed 08/2002 in Japan ITEM #PGC208

Pearl
The best reason to play drums.

General Catalog 2002

Pearl Drums









































and **Pearl Percussion**



Pearl Drums and Percussion

www.pearldrum.com

GENERAL CATALOG 2002

 Chad Smith Red Hot Chili Peppers USA	 Mike Mangini Steve Vai USA	 Vinnie Paul PANTERA USA	 Jimmy DeGrasso Independent USA	 Scott Rockenfield Queensryche USA	 Eric Singer Alice Cooper USA	 Tico Torres Bon Jovi USA	 Steve Ferrone Tom Petty USA	 Dennis Chambers Independent USA	 Omar Hakim Independent USA	 Will Kennedy Independent USA	 Horacio Hernandez Independent USA	 Robby Ameen Independent USA	 Jonathan Mover Independent USA	 Marvin "Smitty" Smith Independent USA
 Virgil Donati Planet-X, Ring of Fire USA, Australia	 Wuv POD USA	 Mike Wengren Disturbed USA	 Ken Jay Static X USA	 Bobby Jarzombek Halford USA	 Steve Gillis Filter USA	 Donna C The Donnas USA	 sPaG Mudrayne USA	 Chad Gracey Live USA	 Charlie Grover Independent USA	 Johnny Kelly Type O Negative USA	 Shane Gaalaas Diesel Machine, Cosmosquad USA	 Mitch Dorge Independent Canada	 Paul Delong Independent Canada	 Rick Gratton Independent Canada
 Ian Paice Deep Purple UK	 Darrin Mooney Primal Scream, Gary Moore UK	 Danny Goffey Supergass UK	 Andy Treacey Faithless UK	 Velroy Bailey Independent UK	 Liam Bradley Ronan Keating UK	 Pete Lewinson Eurythmics UK	 Gareth Brown Independent UK	 Jost Nickel Independent Germany	 Angelo Kelly The Kelly Family Germany	 Armin Rühl Herbert Grönemeyer Band Germany	 Christophe Deschamps Independent France	 Aymeric Moneste Silmarils France	 Kirt Rust Independent France	 Félix Sabal LECCO France
 Adams Perry A UK	 Phil Jordan The Music UK	 Manuel de Lucena Sham Spain	 Bandini Independent Italy	 GATTO Independent Italy	 Marangolo Independent Italy	 Lacu Hanoi Rocks Finland	 Jussi 69 The 69 Eyes Finland	 Cesar Zuiderwijk Independent Holland	 Ernst van Eo Independent Holland	 Lucas van Merwijk Independent Holland	 Tomas Haake Meshuggah Sweden	 Christer Sjöström Independent Sweden	 Daniel Erlandsson Arch Enemy Sweden	
 Grant Collins Independent Australia	 Karl Lewis Bachelor Girl Band, Independent Australia	 Jon Farris INXS Australia	 Andy Strachan The Living End Australia	 ZhangJiong life and death Again China	 Igor Cavalera SEPULTURA Brazil	 Carlos Balla Independent Brazil	 Mauricio Leite Independent Brazil	 Claudio Infante Independent Brazil	 Munetaka Higuchi Loudness Japan	 Shuichi "Ponta" Murakami Independent Japan	 Hiro Tsunoda Independent Japan			

Since 1946, Pearl has been creating a range of innovative percussion products that are easy to use, well designed and durable. The key to the whole range is to achieve a great sound whether it's an 8" tom, a pair of Maracaos or a piccolo snare drum.

Pearl now has state of the art production facilities, to produce Drums and Percussion products that are built to exacting standards using the very best materials. At the top of the range, we combine our production expertise with skilled craftsman, to offer a truly custom built concept called MasterWorks and this expertise is used throughout the range of drums. Many of our manufacturing processes are patented, including our "Heat Compression Shell Moulding System" which is designed to enhance the acoustics of the drum shells.

Pearl is the only drum company that has a full range of drums and percussion, from kits used by the worlds most famous players to entry level kits for beginners. From the Masterworks drums to a tension rod, everything is manufactured by ourselves to ensure strict quality control to allow you to play Pearl products with confidence, time after time. The following pages will provide you with a wide choice of the very finest percussion products. Our aim is to ensure you can enjoy making music with the confidence that Pearl will always be there with you.



Design the Kit of Your Dreams. The Choices are Yours.



Choose the Wood.

North American Maple, Scandinavian Birch, African Mahogany, or in any Combination for every drum.



The beauty of Masterworks is the ability to custom configure a kit down to the wood plies used for the shells. A composite shell, featuring more than one wood, is a great way to blend the characteristics offered by different materials.

Choose the Thickness.

4 ply/5mm, 6 ply/7.5mm, 8 ply/10mm, 10 ply/12.5mm

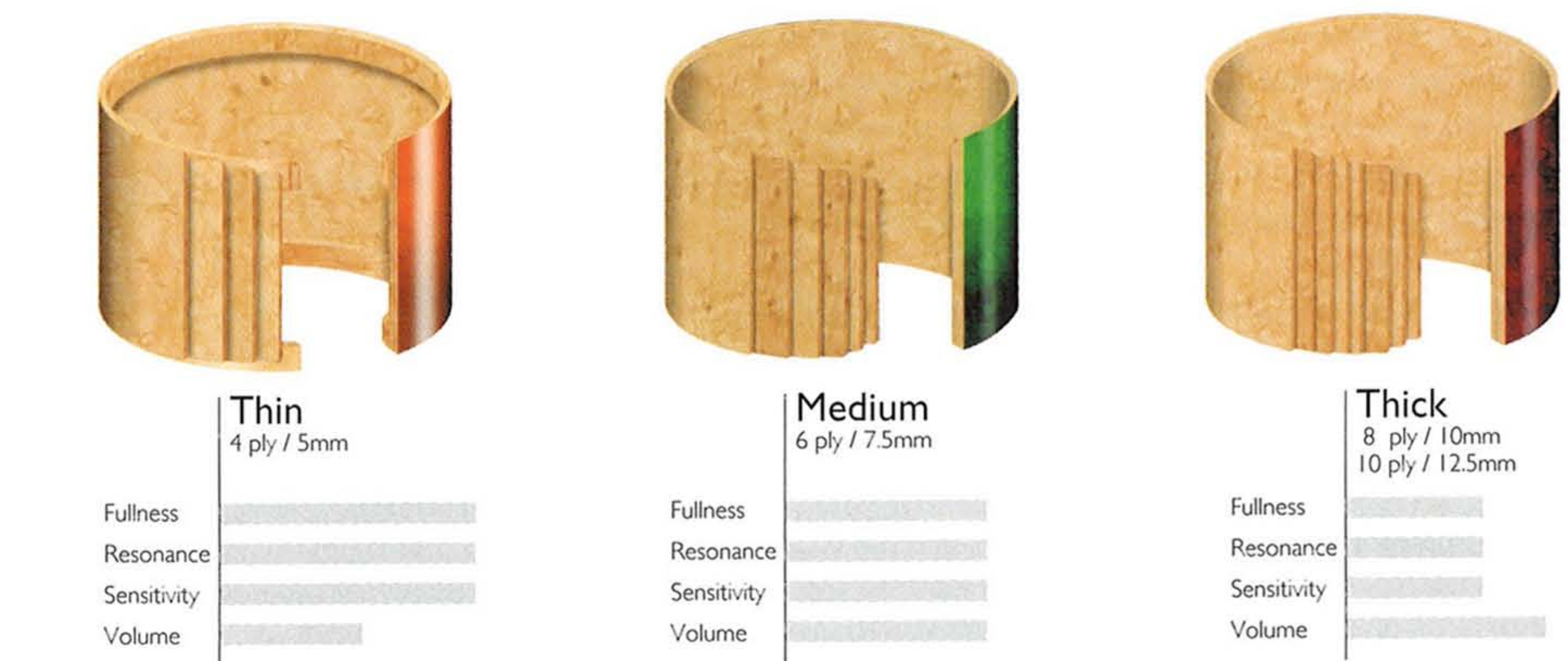

Choose the Sizes.

Most every possible size imaginable for every drum.

Choose the Finish.

Anything is possible. Grain Thru, Bursts, Fades, Metallics, Flakes, Mattes, Opaques, plus Exotic Artisan Wood outer plies.

Choose the Plating.

Chrome, True 24k Gold, Black and Satin Chrome.

Choose the Mounting System.

The Hoops, the Snare Strainer... The options go on and on.

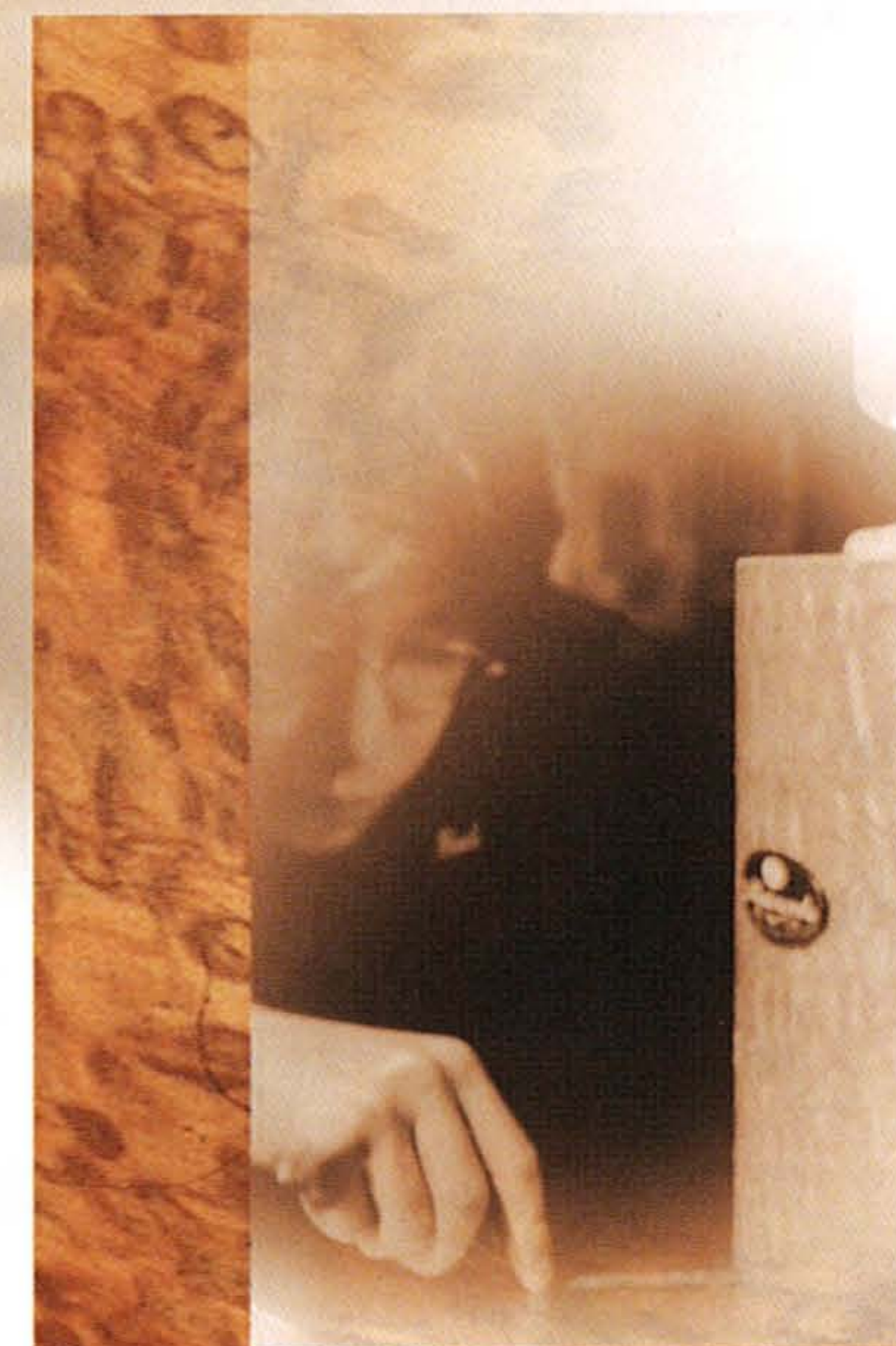

Completely Custom. Totally Hand made.

With no assembly line boundaries and no mass production compromises, Masterworks drums truly represent all that is possible. Each drum is a work of art, constructed by seamlessly blending the artisan qualities and wisdom of hand craftsmanship, with the technology and precision of state of the art custom built machinery. There is no inventory. Every drum in your kit is designed by you, and hand built to your exacting specifications, one drum at a time. We've assembled an elite group of Pearl master craftsmen in order to manufacture the finest drums the world has ever known. Masterworks drums are as individual as you are, and like no other you have heard or seen before.



The Masterworks Finishes

The Masterworks exterior finish represents the most complex offered within the industry today. Each drum will travel through a painstaking thirty-one step, week long process, that starts with a raw shell and ends with a one of a kind work of musical art. Masterworks drums are truly custom and offer endless finishing styles and color possibilities.

Solid color grain-thru finishes provide the look of translucent color encased by layer upon layer of clear lacquer. Exterior plies of Maple or Birch offer the perfect canvas for grain-thru finishing due to the natural beauty of the wood. Mahogany exterior drums are best finished in natural or wine red grain-thru, or in a solid color opaque lacquer finish due to the dark natural coloring of the wood.

Fades and bursts offer a variation of standard grain-thru finishing, allowing you to blend two or more colors together, creating a look that can range from vintage to extremely cutting edge.

Our burnish finishes are a satin oil type natural stain, which colors the wood and creates a beautiful low-gloss alternative look and feel. Opaque finishes are available in any color imaginable with the option to add fine metallics and pearls to the finish. Large and micro-flake sparkle finishes are available also to recreate the classic 60's kit look.

The colors shown on the following pages are just a few of the endless options available when designing your Masterworks kit. We're also happy to match most any sample you might have to create a kit that's truly one of a kind.

Artisan Finishes

Masterworks Artisan Finishes are truly the ultimate expression of quality. These exotic real wood outer plies are formed with the shell offering stunning one of a kind looks to set your kit apart from all others. Three rare woods are available including Bubinga, Burl Mahogany and Tamo. Bubinga is a native African wood and is only available with a natural clear high gloss lacquer finish due to the depth and darkness of the wood. Our highly figured Burl Mahogany is available as either a clear, high gloss natural finish, or with a beautiful dark red stain applied before finishing, for the timeless look of supreme elegance. Tamo offers endless finishing options because its light, natural color, with exotic grain pattern, provides the perfect canvas. Most any grain-thru finishing technique, including solids, fades and sunburst colors, can be applied to Tamo allowing the natural beauty of the grain to create a remarkable visual. When choosing an Artisan finish please be aware that the Artisan outer ply is 2 plies thick. For example, a 4 ply Artisan shell would be made of 2 outer Artisan plies, plus two inner plies of your choice.



Masterworks Scubablue, Tamo Finish



Masterworks Antique Fade, Flame Maple Finish (Limited Edition)

- 3 Ply 100% Maple Shells with an Outer Ply of Flame Top Maple
- Antique Fade Finish with Super Clear Hi-Luster Lacquer Top Coat



Masterworks Carbonply Maple Finish

- Carbon Fiber Inner and Outer Plies, 6 Ply 5.4mm 100% Maple Core
- Same Pricing as Lacquer Finished Masterworks

This hybrid kit is as futuristic as they come with a sound that is equally ahead of its time. If you feel that you lack "Stage Presence", this kit can make up for it with looks alone. And when you strike the first note, you'll realize what Masterworks is all about.... Unparalleled quality. Carbonply Maple's distinctive sound results from joining the 6-ply 5.4mm 100% Maple shell with an inner and outer layer of Carbon Fiber. This highly evolved combination creates a sumptuous sonic sandwich that provides a sound and response unlike anything you've ever played before.



Bubinga Burl Mahogany Red Burl Mahogany



Natural Tamo Teal Tamo Tamo Tabacco Fade See-Thru Green Tamo Tamo Scarlet Fade



THE MASTERS

IT'S THE SOUND.



Pearl's manufacturing excellence in producing the world's finest drums spans well over half a century. Through the continuing evolution of the acoustic drumset, Pearl's Masters Series drums have become the most advanced, best sounding acoustic drums available at any price. Today's Masters Series is about choice. No other drum series offers

the variety and spectrum of tonal control provided by Masters' four distinctively different shell construction choices. Whether you choose our classic Masters Custom MMX 4 ply 100% Maple shell with proportional reinforcement rings, the thicker more powerful Masters Custom MRX 6 ply 100% Maple shell, our vintage style Masters MHX 100% African Mahogany shell, or our Masters Studio BRX 6 ply, 100% Birch shell, you can rest assured your Masters Series drums represent the ultimate instrument for the true professional drummer of today.



Patented Heat Compression Shell Molding System

Pearl's exclusive Heat Compression Shell Molding System consistently produces the finest drum shells on the market today. Hand selected fully aged wood plies are coated with Pearl's patented adhesive formulation which dries to the same density as the wood it binds. The plies are then bonded together using extreme heat and a constant pressure of 70kgf per 1cm² both internally and externally until the shell is thoroughly cured. No other system uses this perfect combination of heat and pressure to insure a perfect drum shell.



Tapered Scarf Joint

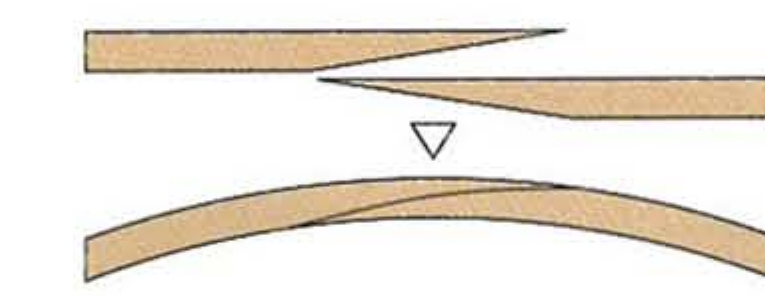

The plies are then bonded together using extreme heat and a constant pressure of 70kgf per 1cm² both internally and externally until the shell is thoroughly cured. No other system uses this perfect combination of heat and pressure to insure a perfect drum shell.

Tapered Scarf Joint Seams

Tapered scarf joint seams allow the plies to overlap, totally eliminating seam butts and dead spots common with other shell manufacturing systems.

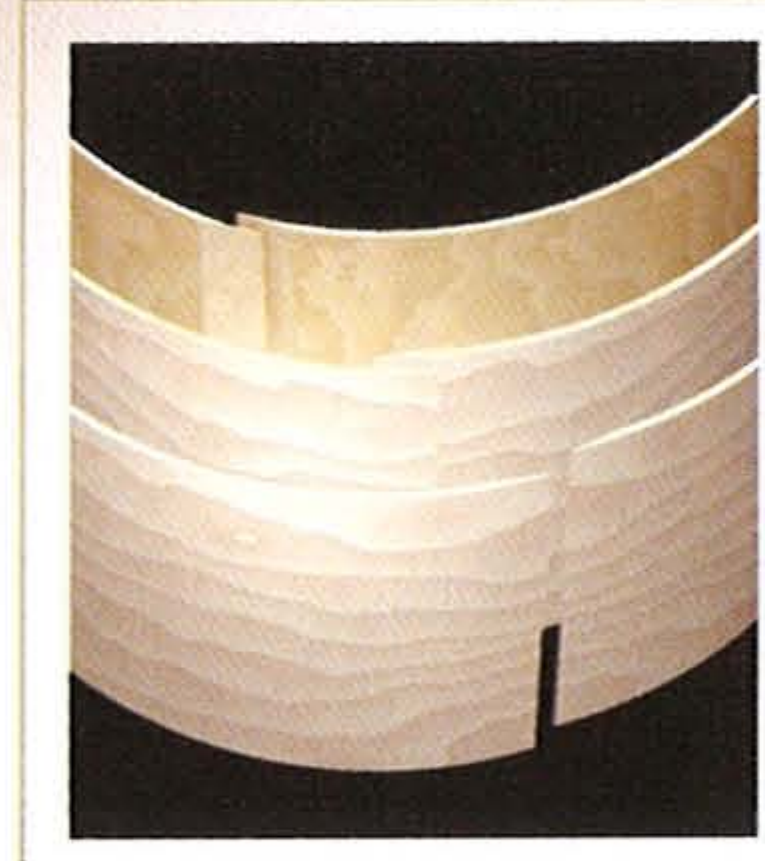

Butt Joint

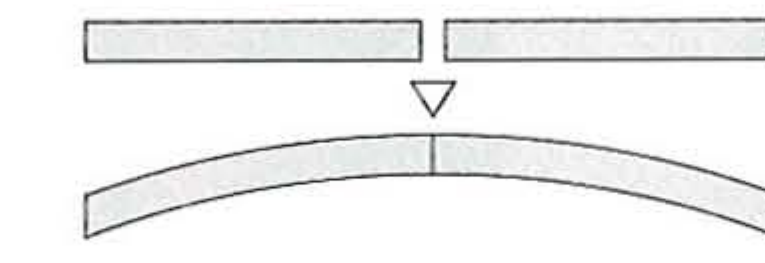

Exclusive Bearing Edge

Our machine cut, precision bearing edge employs a 45 degree in, 45 degree out edge, slightly inset from the exterior to optimize contact with the flat portion of the drum head, and still maintain maximum available diameter.

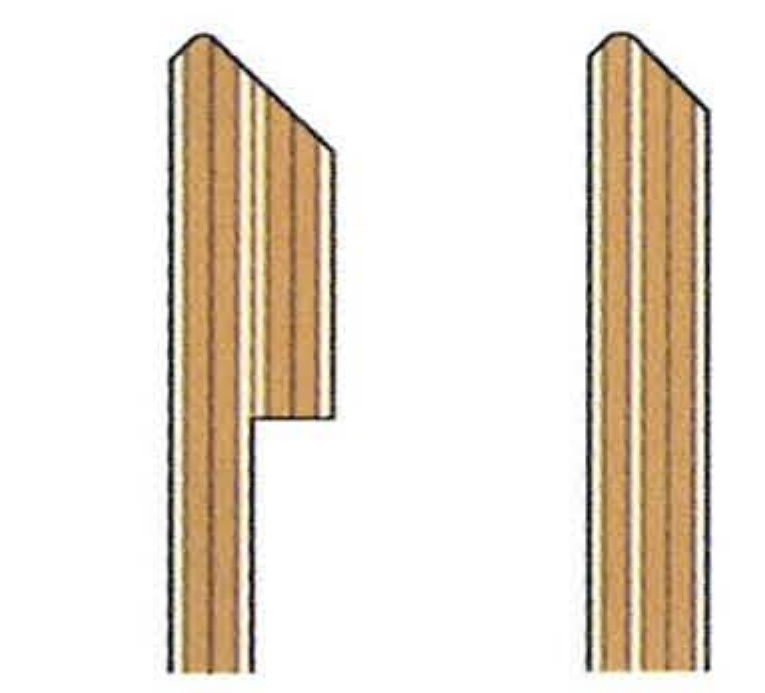

Thirty-One Step Exterior Finish

Masters Series drums feature the finest, most painstakingly beautiful exterior finish in the drum industry today. This exclusive finishing technique takes each Masters Series drum through thirty-one handcrafted steps before completion. The pristine result can be seen in every Fade, Mist, Natural, and solid finish offered within the line. Layer upon layer of clear urethane, highly polished to a glass like appearance, encases your choice of color, with many allowing the natural beauty of the shells' wood grain to show through. One look and you'll see why we say, nothing compares to a Masters finish.

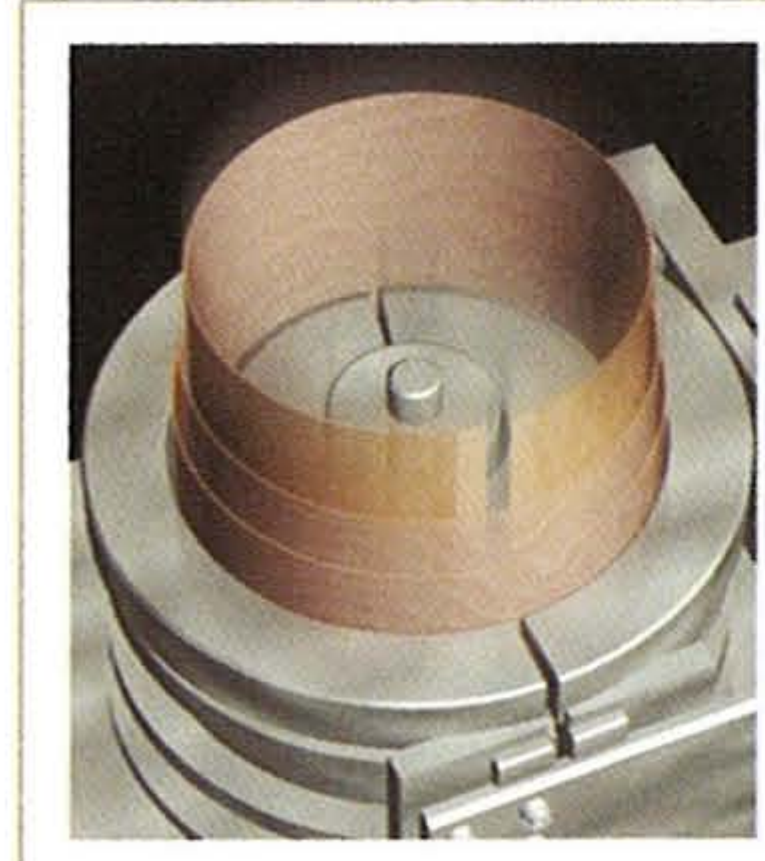

Type-A : Wine Red



Type-B : Midnight Fade

Pearl employs two types of lacquering processes, Type-A for see-through finishes and Type-B for Fades sunburst, and solid colors.

MASTERS IS THE ONLY DRUM SERIES OFFERING ARTISTS A CHOICE OF SHELLS. SHOULD ALL MUSIC SOUND THE SAME? OF COURSE NOT. THE CHOICE IS YOURS.

MASTERS CUSTOM MMX

This is the classic "Masters Sound" offering a thin, 4 ply, 5mm, 100% aged Maple shell with reinforcement rings at both top and bottom. This shell provides great response with a full bodied round tone, with smooth sustain and is easy to tune in any range.



4 ply Maple
+ 4 ply Maple Reinforcement Rings
(5mm + 5mm)

MASTERS CUSTOM MRX

This is Pearl's legendary 6 ply, 100% aged Maple shell. It offers an extremely powerful, solid sound, with great focus, volume, and projection. MRX is a very flexible sound for any type of music offering a great blend of attack and low end presence.



6 ply Maple
(7.5mm)

MASTERS MAHOGANY CLASSIC MHX

Our African Mahogany MHX shell provides an extremely warm, mellow, and deep round tone, with great response. Its sound is very natural and offers the ultimate in low end. The sound of MHX is very reminiscent of the prized vintage drums of yesteryear.



4 ply Mahogany
+ 4 ply Maple Reinforcement Rings
(5mm + 5mm)

MASTERS STUDIO BRX

Our exclusive Masters Studio shell is the perfect alternative to the total Maple sound. Its tone is naturally "EQed" providing great hi-end attack, a slightly reduced mid range, and beautiful low end punch. BRX is a great all around sound for both live and recorded music.



6 ply Birch
(7.5mm)

MASTERS.....
IT'S THE SOUND.



Choice of hardware color

Pearl continues its legacy of innovation by offering drummers four additional choices to make their kit as unique as they are. All Masters Series drums are now available in your choice of Chrome, Gold, Satin Chrome, or Black Chrome plated hardware finishes.



Gold Plated Hardware
in #151 Platinum Mist

Satin Chrome Plated Hardware
in #168 Ocean Sparkle

Black Chrome Plated Hardware
in #154 Midnight Fade

MasterCast Hoops

Pearl's Exclusive Die-Cast Hoops

Our MasterCast hoops are standard equipment on all Masters Series toms and floor toms. They significantly improve sound focus and provide

an exciting explosive dynamic to the overall tone of each drum.

MasterCast hoops also provide a smooth exclusive look and offer the ultimate in both strength, precision and tuning integrity.

"Precision-fit" Stainless Steel Tension Rods

Our Precision-Fit Stainless Steel Tension Rods are now standard equipment as are Masterworks-style rubber gaskets under the lugs.

Pearl's Stainless Steel Tension Rods are machined, not forged, from a single piece of stainless steel to the most exacting tolerances in the industry. They feature super-smooth, precise tensioning, with absolutely no play. Each non-plated stainless steel tension rod is matched with a precision-machined brass swivel nut for ultra-precise metal-to-metal performance.



Die-Cast Claws

All Masters Series bass drums feature die-cast claws with recessed key bolts and rubber hoop isolators. The smooth formed die-cast design with recessed key bolt helps eliminate the rough edges and protruding bolts common with many bass drum claws from other manufacturers, and the rubber isolator provides complete protection for your lacquer finished hoop while allowing maximum resonance.

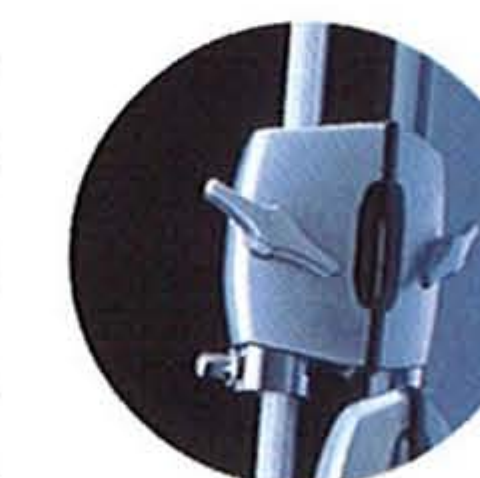

OptiMount Suspension System

Our OptiMount Suspension System mounts to the tom's tension rods and floats totally insulated on rubber cushions, providing the ultimate in stability while allowing the drum to resonate fully unrestricted. With OptiMount, the mounting hardware is completely removed from the drum shell providing a drastic improvement in resonance and sustain.



Uni-Lock System Tom Holder

Our TH-100 Tom Holder is the strongest, most durable and easily adjustable tom holder we have ever made. The TH-100 provides over 180 degrees of vertical adjustment and a full 360 degrees rotation, without changing the height or rotation within the bass drum mount. Our patented Uni-Lock design offers a smooth continuous feel and seemingly endless positioning possibilities and is securely locked with a turn of a drum key.

Minimal Contact for Maximum Resonance

All hardware attached to a Masters Series drum has been kept to a minimum. Our low-mass bridge style tension lugs and air suspension floor tom feet are two perfect examples of Masters design philosophy. Less hardware and mass touching the shell equates to greater unrestricted resonance and lasting sustain. These innovative hardware designs, together with our patented OptiMount Suspension System, proprietary shell construction method and hand selected aged woods, holds the key to the unmatched "Masters" sound.

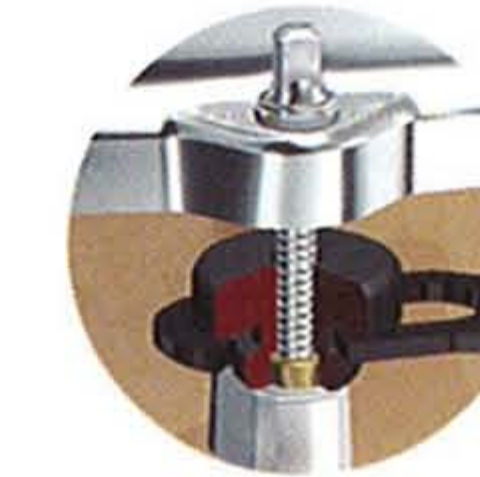

Remo® Drum Heads

All Masters Series drums feature Remo® Drumheads including a clear Powerstroke 3 for the bass drum batter side, and an Ebony Powerstroke 3 with Pearl logo for the front. Powerstroke 3 is the most popular bass drum head on the market today due to its unique natural overtone muffling system that helps Masters bass drums produce thunderous bass. All Masters toms and floor toms come standard with Remo's Clear Ambassador heads which help create a bright tone with powerful attack and superior sustain.

Masters.

The most innovative, most versatile drums ever designed. Specially built for the way you play now.

THE NEW KIT IS HERE. SO MUCH EXCITEMENT. YOU ALMOST FEEL LIKE A LITTLE KID AGAIN. THE SHELL MATERIAL, THE CONFIGURATION, THE SIZES, FINISH, AND EVEN THE COLOR OF THE HARDWARE..... ALL OF THESE ARE YOUR CHOICES. WITH THIS KIT IN A REHEARSAL STUDIO, IT'S TIME TO CREATE YOUR SOUND, YOUR SET-UP, A SIGNATURE THAT IS YOURS AND YOURS ALONE. MASTERS IS TOTALLY VERSATILE. MAKE THEM SOUND EXACTLY LIKE YOU WANT. WHATEVER YOU PLAY, NU METAL, ALTERNATIVE, PUNK, OR FUNK, WITH YOUR STYLE AND THESE DRUMS, IT'S EASY TO UNDERSTAND WHY THEY SAY... MASTERS, IT'S THE SOUND.



Masters
It's the sound.



MASTERS CUSTOM MMX

Bass Drum : MMX2218BX/S
Tom Tom : MMX1008T/S, MMX1209T/S, MMX1411T/S, MMX1613T/S
Snare Drum : MMX1455S/S
Quarter Tom : AL-612, AL-615
Hardware & Accessories : H-2000, P-2002C, S-2000, B-855W(6), CH-70(2), CST-80, T-980W(3), PS-85
 #168 Ocean Sparkle

MASTERS MAHOAGANY CLASSIC MHX

Bass Drum : MHX2218BX/C
Tom Tom : MHX1008T/C, MHX1209T/C
Floor Tom : MHX1414F/C, MHX1616F/C, MHX1816F/C
Snare Drum : MHX1455S/C
Hardware & Accessories : H-855, S-885W, P-101P, B-855W(4), T-980W, CH-88, CH-70, CLH-100, AX-28(2)
 #141 Red Mahogany



MASTERS CUSTOM MRX

Bass Drum : MRX2218BX/B
Tom Tom : MRX1008T/B, MRX1209T/B
Floor Tom : MRX1411T/B
Snare Drum : MRX1455S/B
Hardware & Accessories : H-2000, P-2000C, S-985W, B-855W(2), TC-980W(3)
 #103 Piano Black

Masters.

An incredible sound,
as individual as you are.

WALKING AWAY FROM SOUND CHECK,
AS YOU'VE DONE COUNTLESS TIMES IN YOUR CAREER,
YOU GET A CHANCE TO THINK ABOUT THE BAND, YOUR EQUIPMENT,
AND HOW IT ALL COMES TOGETHER TO CREATE A SOUND
AS INDIVIDUAL AS YOU ARE.
WHEN THERE'S NO CROWD AND NO HYPE,
YOU GET TO TRULY LISTEN TO YOUR DRUMS.
THAT INCREDIBLE SOUND.
A SOUND THAT IS BOTH PASSION AND CRAFTSMANSHIP.
THAT SOUND IS THE REASON WHY PEARL IS THE ONLY KIT
YOU'VE EVER PLAYED... AND THE REASON WHY THESE ARE
THE ONLY DRUMS YOU'LL EVER NEED.



Masters
It's the sound.



MASTERS CUSTOM MRX

Bass Drum : MRX2418BX/B
Tom Tom : MRX1311T/B
Floor Tom : MRX1616F/B, IMRX1818F/B
Snare Drum : UCA1450
Hardware & Accessories :
 H-2000, P-2000C, S-2000(2), B-855WL, B-855W, BC-800W,
 C-855W(3), CH-88, CST-80, AX-20, CA-100, ECB-10

#154 Midnight Fade

MASTERS CUSTOM MMX

Bass Drum : MMX2218BX/C
Tom Tom : MMX1008T/C, MMX1208T/C, MMX1309T/C
Floor Tom : MMX1414F/C, MMX1616F/C, MMX1818F/C
Snare Drum : DC1465
Hardware & Accessories :
 DR-503, PC-50(7), H-2000, P-2002C, S-985W, CH-88(6),
 CLH-100, 75X, ECB-5, TH-100S(3)

#100 Wine Red



MASTERS CUSTOM MMX

Bass Drum : MMX2416BX/S, MMX2016BX/S
Tom Tom : MMX0807T/S, MMX0808T/S, MMX1008T/S(2), MMX1208T/S, MMX1209T/S
Floor Tom : MMX1414F/S, MMX1616F/S
Snare Drum : UCA1450
Hardware & Accessories :
 H-2000, HA-100, RH-2000, P-2002C, P-2002CI, S-2000,
 T-980W(3), B-855WL(4), B-855W, BC-800W, BA-92BW,
 TH-100, AX-25L, DCL-90, CST-80, PS-85(2), PPS-37, PTM-10GH

#156 Purple Storm

Masters.

The only drum series with a choice of shells, and sounds, for the professional drummer.

AS YOU MAKE YOUR WAY INTO THE STUDIO, YOU MIGHT THINK BACK ABOUT ALL THOSE ARTICLES YOU'VE READ. THE ONES ABOUT GUYS THAT KEEP HUNDREDS OF EXOTIC AND VINTAGE DRUMS AROUND TRYING TO GET THAT PERFECT SOUND. RIGHT ABOUT THEN YOU'LL REALIZE, YOU ALREADY PLAY THE ONLY DRUM SERIES IN THE WORLD WITH A CHOICE OF SHELLS, AND SOUNDS. AFTER ALL, IT'S YOU WALKING INTO THE STUDIO... TO SIT BEHIND THE ONLY KIT YOU'VE EVER NEEDED.



MASTERS CUSTOM MMX
Bass Drum: MMX2216BX/C
Tom Tom: MMX1010T/C, MMX1210T/C
Floor Tom: MMX1414F/C, MMX1616F/C
Snare Drum: SF1465
Hardware & Accessories: H-2000, P-2000C, S-985W, B-855W(5), TH-100S(2), AX-20(2)
 #153 Sunrise Fade



Masters
It's the sound.



MASTERS STUDIO BRX
Bass Drum: BRX2218BB/G
Tom Tom: BRX0807T/G, BRX1008T/G, BRX1210T/G, BRX1411T/G, BRX1613T/G
Snare Drum: BRX1455S/G
Hardware & Accessories: H-2000, RH-2000, CLH-100, P-2002C, S-2000, DR-503, PC-50(9), TH-100S(6), CH-88L, CH-88(7), AX-25L, PS-85
 #151 Platinum Mist



MASTERS CUSTOM MRX
Bass Drum: MRX2418BB/C
Tom Tom: MRX1008T/C, MRX1210T/C, MRX1311T/C, MRX1412T/C, MRX1513T/C
Floor Tom: MRX1616F, MRX1816F
Snare Drum: STB1465
Hardware & Accessories: H-2000, P-2002C, S-985W, B-855WL(3), CH-88(2), TH-100(3), TH-100S(2), AX-38(2), AX-20
 #160 Silver Sparkle

Masters
It's the sound.

Masters Series
Model Number
Specification Chart

	Diameter x Depth		Size Code #	
			w/o BB-3	w/ BB-3
Bass Drum	18" x 14"		1814BX	1814BB
	18" x 16"		1816BX	1816BB
	20" x 14"		2014BX	2014BB
	20" x 16"		2016BX	2016BB
	22" x 16"		2216BX	2216BB
	22" x 18"		2218BX	2218BB
	24" x 16"		2416BX	2416BB
	24" x 18"		2418BX	2418BB
Floor Tom	14" x 14"		1414F	
	16" x 16"		1616F	
	18" x 16"		1816F	
Tom Tom	8" x 7"		0807T	
	8" x 8"		0808T	
	10" x 8"		1008T	
	10" x 9"		1009T	
	10" x 10"		1010T	
	12" x 8"		1208T	
	12" x 9"		1209T	
	12" x 10"		1210T	
	13" x 9"		1309T	
	13" x 10"		1310T	
	13" x 11"		1311T	
	14" x 10"		1410T	
	14" x 11"		1411T	
	14" x 12"		1412T	
	15" x 13"		1513T	
	15" x 14"		1514T	
	16" x 13"		1613T	
16" x 14"		1614T		

New Component
Numbering
System

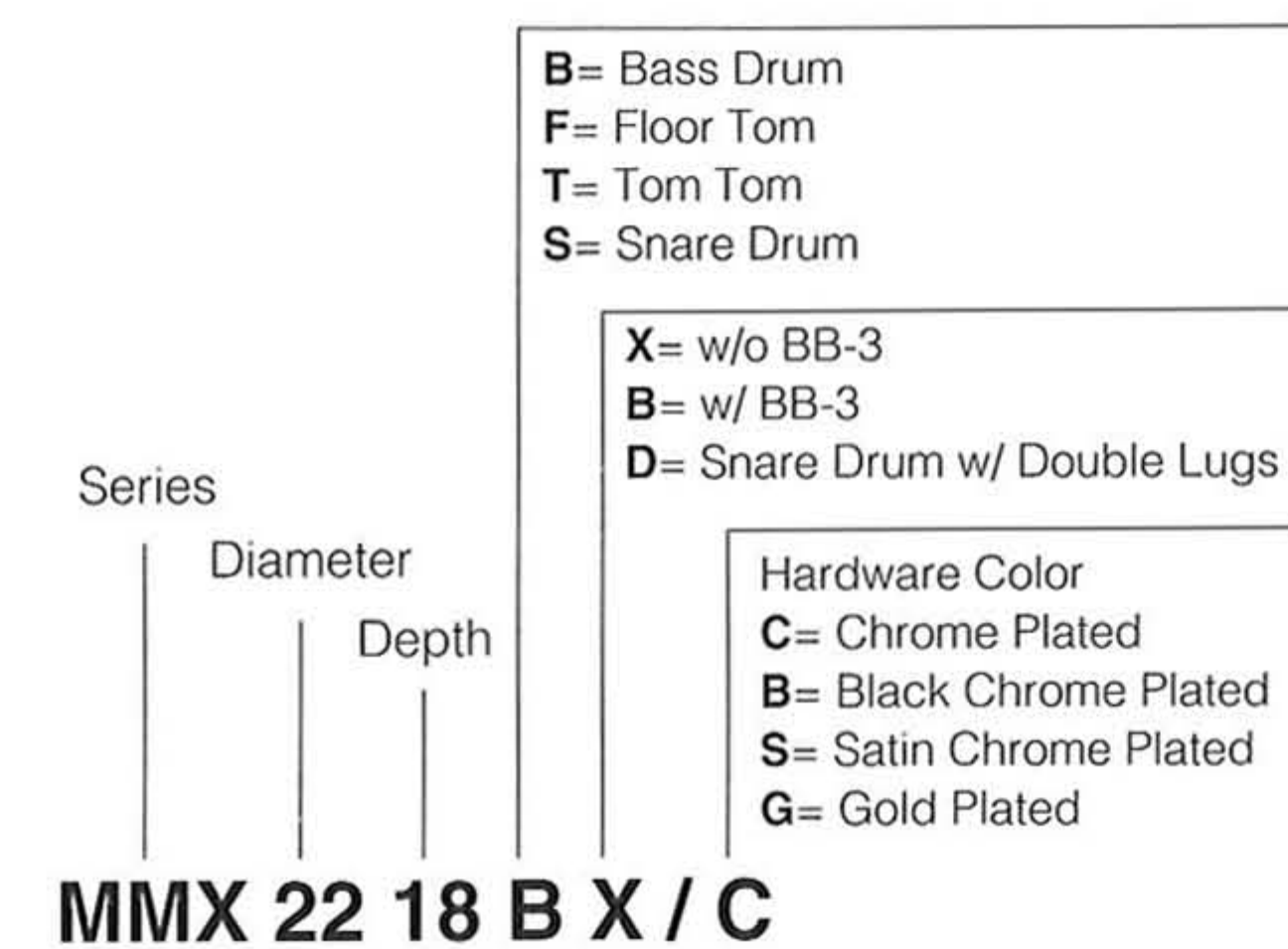

Masters Series
Available Colors

- No. 100 Wine Red
- No. 102 Natural Maple
- No. 103 Piano Black
- No. 112 Natural Birch
- No. 122 Black Mist
- No. 128 Vintage Sunburst
- No. 141 Red Mahogany
- No. 151 Platinum Mist
- No. 152 Antique Gold
- No. 153 Sunrise Fade
- No. 154 Midnight Fade
- No. 156 Purple Storm
- No. 160 Silver Sparkle
- No. 168 Ocean Sparkle

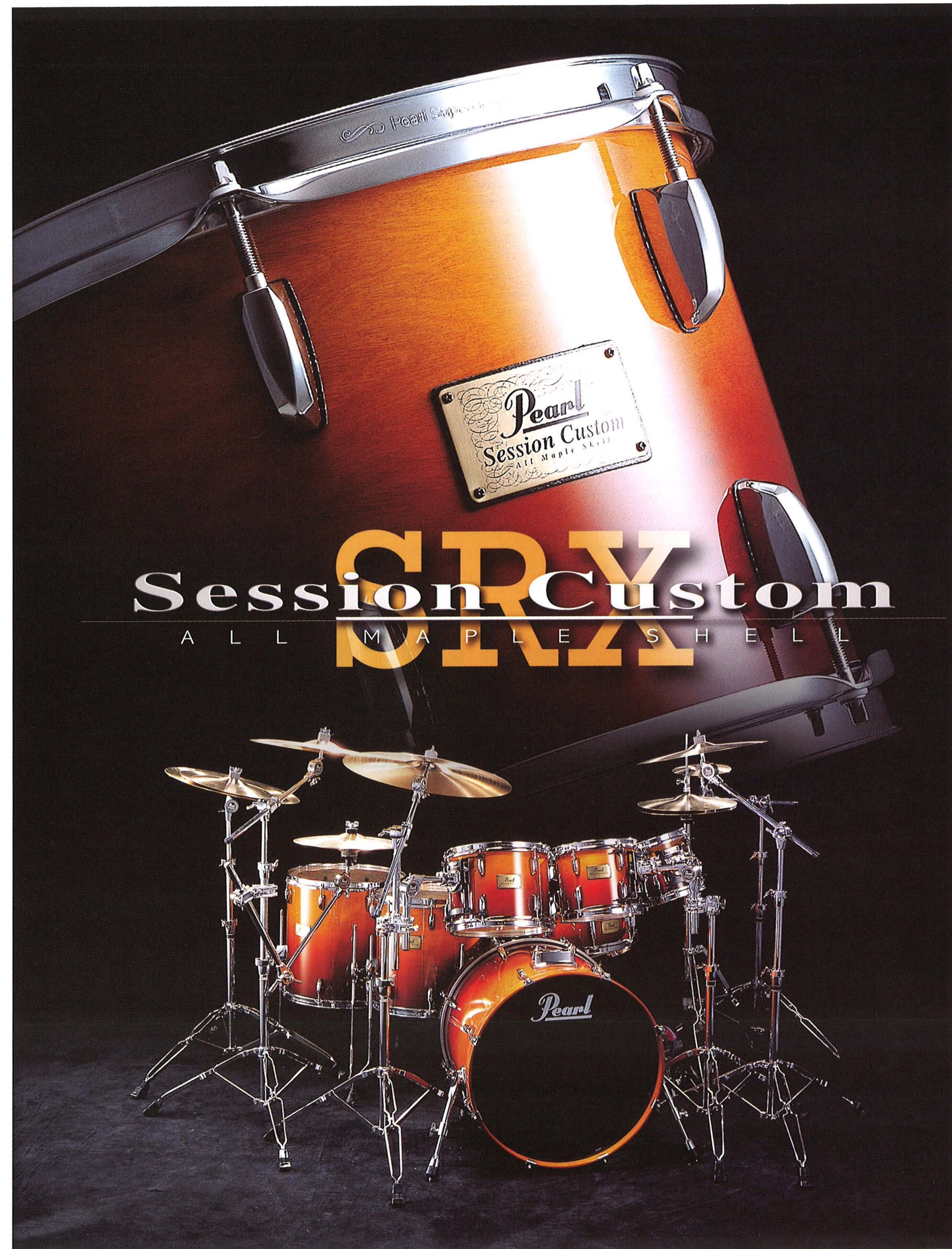

Session Custom
ALL MAPLE SHELL



Pearl's completely new all Maple shell drums for the true working drummer of today.

Pearl's artist roster reads like a carefully compiled list of the top drummers in every type of music imaginable. From straight ahead Rock, Hard Rock and Alternative, to Funk, Jazz, Metal or World Music, Pearl drums offer today's drummer a blank canvas and the perfect tools from which to create a drum sound totally unique to their style of play.

No other drums available offer the versatility, character and tonal quality inherent to Pearl. The awesome sound associated with a Pearl Maple shell is a direct result of our patented Heat Compression Shell Molding System, or HC/SMS as it's known throughout the industry. This exclusive process produces the finest, most superb shell on the market today. Nothing else even comes close.

Session Custom SRX is the newest addition to Pearl's heritage of exclusive 100% Maple based drumsets. Its sound, and many of its features have been passed on from our exclusive Masters Series. Our design philosophy for SRX was simple. Masters Series drums have an unequalled reputation as the finest quality professional kit available. Our new Session Custom SRX hopes to place Masters Series quality, well within the affordable reach of every working drummer.

Session Custom offers an unbelievable set of exclusive features for this price range. Our top of the line OptiMount Suspension System represents a perfect example. OptiMount grips the drum by the tension rods, without touching the shell. This allows the shell to resonate completely unrestricted providing increased sustain, tonal depth and amazing presence. And features like our 2.3mm solid steel SuperHoop II rims, our all new 2 ply ProTone Heads, low-mass lugs, and beautiful highly polished lacquer finishes, all combine to create a kit that looks, sounds and performs far above kits costing twice as much. The configurations shown within this catalog could well be signature kits from some of our top artists. They represent the essence of our new Session Custom SRX. For a kit geared toward the working drummer, dependability and uncompromising performance for live work is a must, combined with the tonal sophistication and quality of sound needed for studio work. This is what SRX is all about...supreme quality drums, for true working drummers.

100% 6 ply Maple Shell

Pearl's exclusive Maple Shell is produced by our patented Heat Compression Shell Molding System. Its strength, tonal sophistication, and quality provide a perfectly balanced sound with an ultra-wide tuning range. This is the same process used to produce our Masters Series drums and is used by every Pearl artist throughout the world.

OptiMount Suspension System

Our OptiMount Suspension System mounts to the tom's tension rods and floats totally insulated on rubber cushions, providing the ultimate in stability while allowing the drum to resonate fully unrestricted. With OptiMount, the mounting hardware is completely removed from the drum shell providing a drastic improvement in resonance and sustain.



SuperHoop II

Our solid steel SuperHoop II rims help provide tonal flexibility for a wider range of tunings, and provide both strength and tuning integrity. This allows Session Custom SRX to offer a greater range of character perfect for any style of music.



Matching Maple Bass Drum Hoops

Session Custom SRX bass drums feature 100% Maple hoops with matching exterior lacquer finish. Together with our die-cast claws and sleek drum key tension bolts, they provide supreme dependability, and the ultimate tuning integrity.



Uni-lock Tom Holders

Our TH-98 tom holders provide over 180 degrees of vertical adjustment and a full 360 degrees of horizontal movement for seemingly endless tom positioning options. Pearl's patented Uni-lock system has a super smooth continuous feel without preset gear positions and is locked using a standard drum key.

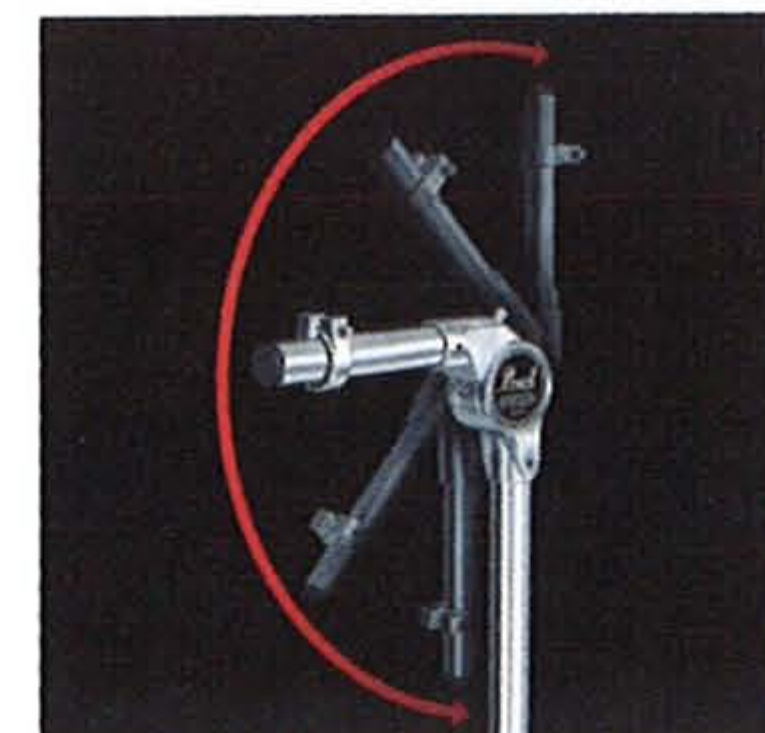

Air Suspension Tom Legs

Our Air Suspension floor tom legs make a remarkable difference by counteracting the deadening effects of the floor. They add exceptional sustain while also enhancing tone, depth and resonance. Their design is simple yet ultimately effective, featuring a proprietary soft rubber compound in combination with an ingenious air hollow.

SP-30 Telescoping Spurs

All Session Custom SRX bass drums feature our SP-30 telescoping bass drum spurs. Designed for the professional drummer, the SP-30 spur is extremely quick to position, easy to adjust, and with its quarter turn spike to rubber tipped feet, it offers the absolute ultimate in stability on most any playing surface.

Pearl ProTone Heads



Matching All Maple Snare Drum

The Snare Drum is the nucleus of a kit's sound. Session Custom SRX kits feature a matching 100% Maple Snare Drum to perfectly match the warmth, body, and tonal qualities offered by the Toms and Bass.



Super Professional Hardware

Pearl's hardware has long been considered the standard by which all others are judged. The hardware that accompanies every Session Custom SRX pre-packaged kit includes our extremely smooth H-855 Hi-Hat with swiveling leg tripod, our sturdy S-885W Snare Stand with Uni-lock Tilter, and what many consider the best cymbal stands available, our double braced C-855W and B-855W.

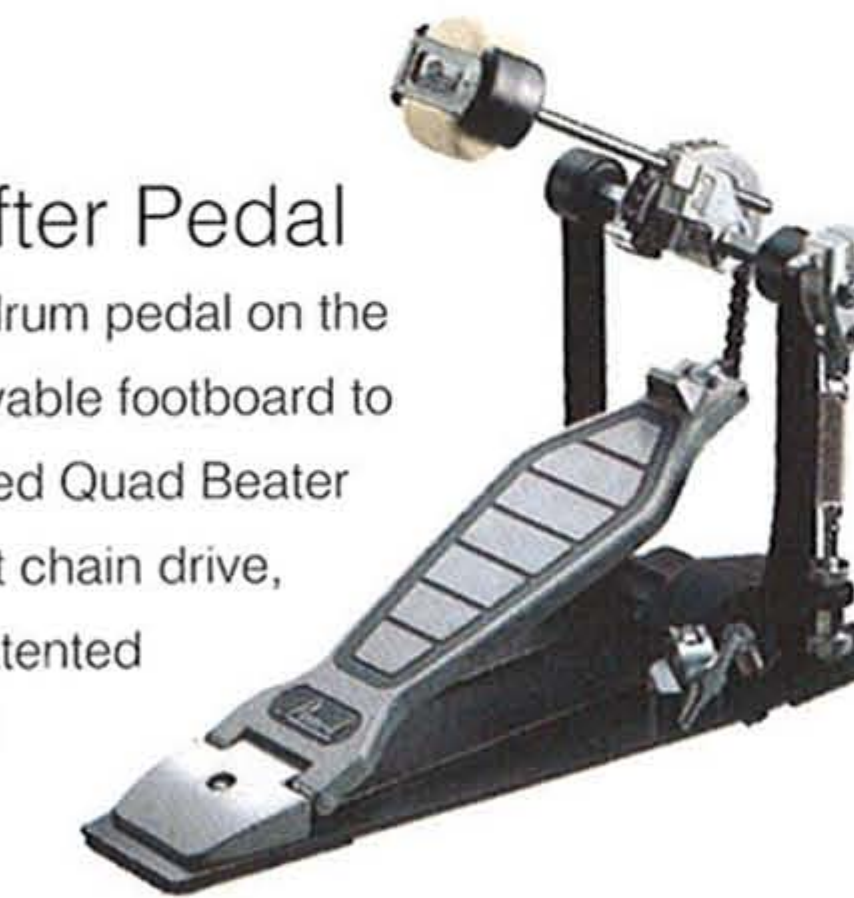

Revolutionary PowerShifter Pedal

PowerShifter is the most exciting bass drum pedal on the market today. Its features include a movable footboard to fine tune the action and feel, our patented Quad Beater with four different beater surfaces, silent chain drive, a roller cam hoop clamp system, our patented Uni-Pressure Spring Clamp, and a solid steel base plate, just to name a few.

SRX

Session Custom

ALL MAPLE SHELL



SRX925

Drums: SRX2216B, SRX1210T, SRX1311T, SRX1616F
Snare Drum: SRX1455S
Hardware: H-855, P-101P, S-885W, C-855W, B-855W
Accessories: TH-98I (2)

#291 Cranberry Fade



SRX925DH

Drums: SRX2218B, SRX1008T, SRX1209T, SRX1412T
Snare Drum: SRX1455S
Hardware: H-855, P-101P, S-885W, C-855W, B-855W
Accessories: TH-98I (2), TH-98S, AX-20

#292 Marine Blue Fade

SESSION CUSTOM



Drums : SRX2216B (2), SRX1210T, SRX1311T, SRX1616F
Snare Drum : SRX1455S
Hardware : H-855, P-101P (2), S-885W, B-855W (5), T-980W
Accessories : CH-88 (2), HA-100
 #281 Carbon Mist



Drums : SRX2418B, SRX1814B, SRX0808T, SRX1009T, SRX1210T, SRX1414F, SRX1616F
Snare Drum : SRX1455S
Hardware : H-2000, P-2002C (2), S-985W, B-855WL (2), B-855W (3), TC-900W (2)
Accessories : TH-98I, CH-88, CH-70 (2), CLH-100 (2), AX-28 (2), PS-85 (2)
 #285 Dusk Blue



Drums : SRX2218B, SRX0807T, SRX1008T, SRX1209T, SRX1414F, SRX1616F
Snare Drum : SRX1455S
Hardware : H-2000, P-2002C, S-985W, DR-503
Accessories : TH-98I, TH-98S (2), CH-88L (2), CH-88 (4), CLH-100, PC-50 (5), 75X, ECB-7, PS-85
 #290 Vintage Fade



Drums : SRX2218B, SRX1008T, SRX1209T, SRX1412T, SRX1614T
Snare Drum : SRX1455S
Hardware : H-855, P-101P, P-101TW, S-885W, DR-503
Accessories : TH-98I (2), TH-98S (2), CH-88L, CH-88 (4), PC-50 (5), 75H, ECB-7, PS-85
 #288 Burnt Amber



Session Custom SRX

... supreme quality drums, for true working drummers.

Basic Drum Set Packages:

Model #:	SRX905	SRX905H	SRX925	SRX925DH
Shell Pack:	SRX905-P	SRX905H-P	SRX925-P	SRX925DH-P
Bass Drum	20"x16" SRX2016B	20"x16" SRX2016B	22"x16" SRX2216B	22"x18" SRX2218B
Tom Toms	10"x 8" SRX1008T 12"x 9" SRX1209T	10"x 8" SRX1008T 12"x 9" SRX1209T 14"x12" SRX1412T	12"x10" SRX1210T 13"x11" SRX1311T	10"x 8" SRX1008T 12"x 9" SRX1209T 14"x12" SRX1412T
Floor Tom	14"x14" SRX1414F		16"x16" SRX1616F	
Snare Drum	14"x5.5" SRX1455S	14"x5.5" SRX1455S	14"x5.5" SRX1455S	14"x5.5" SRX1455S
Tom Holder	TH-98I (2)	TH-98I (2)	TH-98I (2)	TH-98I (2)
Tom Holder, Short		TH-98S		TH-98S
Adapter		AX-20		AX-20
Hardware Pack:	HW-80	HW-80	HW-80	HW-80
Hi-Hat Stand	H-855	H-855	H-855	H-855
Snare Drum Stand	S-885W	S-885W	S-885W	S-885W
Cymbal Stand	C-855W	C-855W	C-855W	C-855W
Cymbal Boom Stand	B-855W	B-855W	B-855W	B-855W
Drum Pedal	P-101P	P-101P	P-101P	P-101P

Component Drums :

Size	Model #	Size	Model #
Bass Drums		Tom Toms (w/OptiMount System)	
18" x 14"	SRX1814B	8" x 7"	SRX0807T
18" x 16"	SRX1816B	8" x 8"	SRX0808T
20" x 16"	SRX2016B	10" x 8"	SRX1008T
22" x 16"	SRX2216B	10" x 9"	SRX1009T
22" x 18"	SRX2218B	10" x 10"	SRX1010T
24" x 16"	SRX2416B	12" x 8"	SRX1208T
24" x 18"	SRX2418B	12" x 9"	SRX1209T
Floor Toms		12" x 10"	SRX1210T
14" x 14"	SRX1414F	13" x 9"	SRX1309T
16" x 16"	SRX1616F	13" x 10"	SRX1310T
18" x 16"	SRX1816F	13" x 11"	SRX1311T
Snare Drums		14" x 11"	SRX1411T
14" x 5.5"	SRX1455S	14" x 12"	SRX1412T
14" x 6.5"	SRX1465S	15" x 13"	SRX1513T
		15" x 14"	SRX1514T
		16" x 13"	SRX1613T
		16" x 14"	SRX1614T

Size : Diameter x Depth

SRX Available Finishes:

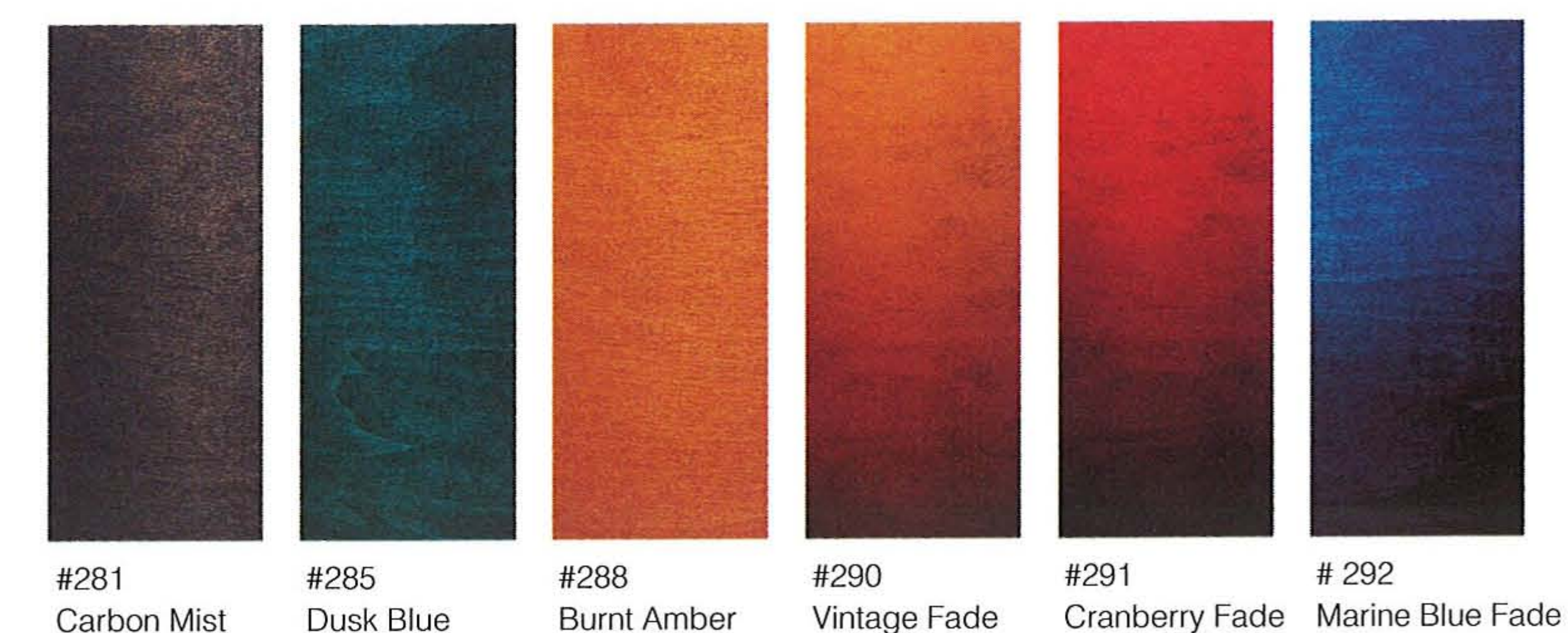

#281 Carbon Mist #285 Dusk Blue #288 Burnt Amber #290 Vintage Fade #291 Cranberry Fade #292 Marine Blue Fade

ELX EXPORT SELECT

One look and listen to our all Export Select Series, and you'll understand exactly what all the fuss is about. Our complete redesign has given these drums the look, sound, features, and performance of true hi-end drums, but without the forbidding hi-end price tag. Export Select offers unheard of value and performance, far superior to any other kit in its price range. That's why you see Export Select kits on stage after stage, played by true working drummers all over the world. Our exclusive low mass lugs on ELX mimic the look of our acclaimed hi-end Masters Series drums, and stunning lacquer finishes allow the visual prestige of its premium natural wood grain to show through. When you dig deep into the features of ELX, you'll find they're hi-end all the way. Features like our patented Integrated Suspension System Tom Mounts on all mounted toms for an amazingly live tone, a matching wood shell 14"x5.5" Snare Drum, a full set of our road ready 800W double braced hardware, our PowerPro Chain Drive Bass Drum Pedal with the DouBeat Beater System, and all drums are fitted with quality ProTone heads, including our ProTone Bass Drum heads with a self-muffling perimeter EQ System. If you're searching for the true leader in this price range, then your search is definitely over. Export Select for sound, looks, performance and quality, any other kit seems a distant second choice.

EXPORT SERIES

THE BEST MADE, BEST SELLING DRUMS IN THE WORLD

EX EXPORT



NEW HI-END STYLING

Our Export and Export Select Series drums feature a boldly exciting low mass split lug design with a strong family resemblance to our hi-end Masters and handmade Masterworks drums. The look is unmistakably Pearl, right down to Export's etched badges and color choices.

I.S.S. TOM MOUNTS

Pearl's Integrated Suspension System Tom Mounts grip the drum by the rim, without touching the shell. This allows the tom to resonate completely unrestricted. The effect on both tone and sustain is extremely dramatic. There is no system on the market today that offers the simplicity and overall effectiveness of Pearl's I.S.S. mounts.

ALL POWERPRO HARDWARE

Both Export and Export Select prepackaged kits feature a full set of the most popular hardware line we offer...800W PowerPro. This isn't some cheap hardware you'll break or trade in next year. This is the same hardware some of the world's top players tour the world with. Each kit features a fully adjustable S800W Snare Stand, a Chain Drive H800W Hi-Hat Stand with swiveling legs, a double braced BC800W Cymbal Boom Stand that easily converts to straight or boom, a double braced C-800W Cymbal Stand and our famous chain Drive P100 PowerPro Bass Drum Pedal with the DuoBeat dual sided beater system.

MATCHING SNARE DRUM

Nothing compliments the look and sound a high quality kit like a perfectly matched Snare Drum. Every Export and Export Select kit features a matching wood shell 14"x5.5" Snare Drum for the ultimate in warmth, tone, and ear splitting attack.

How do you top the best selling, most widely played drumset in the world for the last ten years running? Easy. Refine the look to full hi-end status and add a host of incredible features. Introducing the Export Series. The kit that sets the standard for all others to follow just keeps getting better and better. Export has long been a favorite with its road ready durable covered finish, and now with our exclusive split low mass lugs and etched badges, its look is nothing short of stunning. But Export is more than just great looks, in fact it shares all the other outstanding features of its sibling Export Select. Features like our I.S.S. Tom Mounts, sturdy 800W Hardware, quality ProTone Heads, matching wood Snare Drum. Features are great, but sound is where Export really shines. Both Export and Export Select share a shell produced by the finest shell forming system in the world, Pearl's exclusive Heat Compression Shell Molding System or HC/sms for short. Its this exclusive system that gives Export the tone, warmth, volume and clarity that has made this series the best selling drumset in the world, year after year after year.

ELX EXPORT SELECT

Shell Material: 6 ply 7.5mm Select Hardwood shells
 Finishes: Super high gloss lacquer

EX EXPORT

Shell Material: 6 ply 7.5mm Select Hardwood shells
 Finishes: Pearl's exclusive covered finishes



ELX 805
#279 Cobalt Mist



ELX 825DH
#274 Amber Mist



EX 825DH
#31 Jet Black



EX 825
#91 Red Wine

COMPLETE KIT CONFIGURATIONS

The easiest way to build your dream kit is to start with one of our standard 5 piece kit configurations shown below. From there you can add on individual components or choose one of our specially priced Expansion Packages to get the kit of your dreams.

ELX KITS	ELX 825	ELX 825DH	ELX 805	ELX 805H
EX KITS	EX 825	EX 825DH	EX 805	EX 805H
Bass Drum	22" x 16"	22" x 18"	20" x 16"	20" x 16"
Tom Toms	12" x 10" 13" x 11"	10" x 8" 12" x 9" 14" x 12"	10" x 8" 12" x 9"	10" x 8" 12" x 9" 14" x 12"
Floor Tom	16" x 16"		14" x 14"	
Snare Drum	14" x 5.5"	14" x 5.5"	14" x 5.5"	14" x 5.5"
Hardware	see notes *	see notes **	see notes *	see notes **

* Hardware set for all EX and ELX kits contains 1 each, H-800W Hi-Hat Stand, S-800W Snare Stand, BC-800W Cymbal Boom Stand, C-800W Cymbal Stand, P-100 Bass Drum Pedal, and 2- TH-881 Tom Holders.
 ** indicates these kits also include all of the above plus 1 TH-88S Tom Holder and 1 AX-20 Adapter.

Free with the Export EX kit is an exclusive instructional video featuring the world class drummer Eric Singer. The video includes details on how to set up the drum kit as well as live footage.

INDIVIDUAL COMPONENTS

Bass Drums	Tom Toms	Floor Toms	Snare Drum
18" x 16" (*)	8" x 8" 13" x 11"	14" x 14"	14" x 5.5"
20" x 16"	10" x 8" 14" x 12"	16" x 16"	
22" x 16"	10" x 10" 15" x 14"	18" x 16"	
22" x 18"	12" x 9" 16" x 14"		
24" x 16"	12" x 10"		

(*) Available in ELX only.

EXPANSION PACKAGES

ELX-6H
EX-6H
8" x 8" Tom Tom
TH-88S Tom Holder
AX-20 Adapter

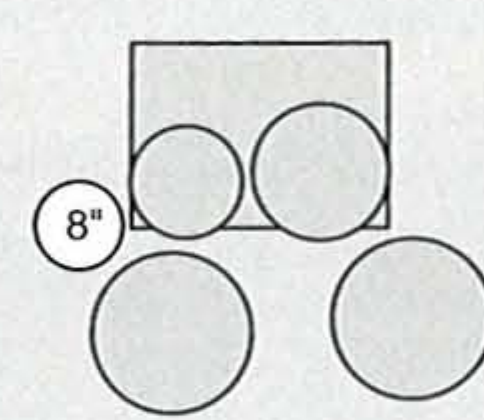

ELX-6
EX-6
10" x 8" Tom Tom
TH-88S Tom Holder
AX-20 Adapter

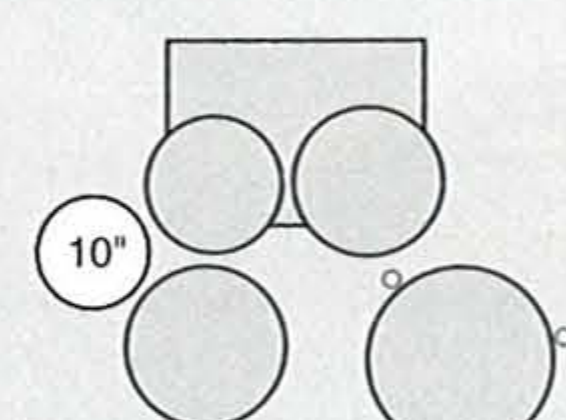

ELX-6F
EX-6F
16" x 14" Tom Tom
TC-800W Cym/Tom Stand

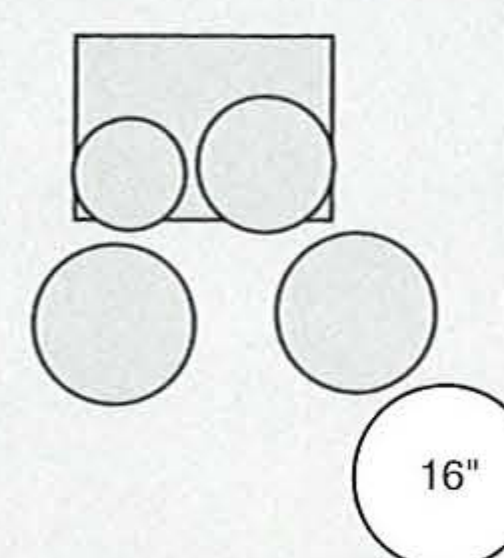

ELX-7P
EX-7P
8" x 8" Tom Tom
10" x 8" Tom Tom
T-800W Tom Stand

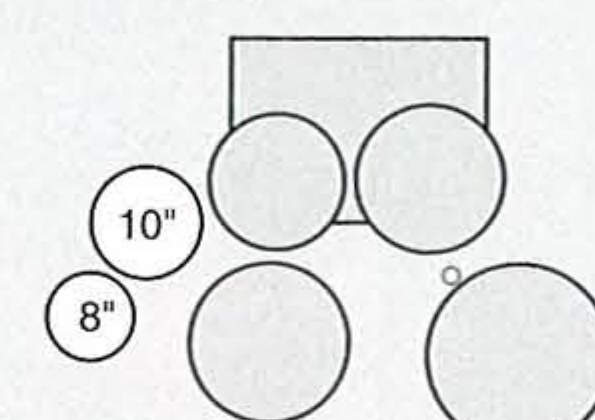

ELX-7
EX-7
10" x 8" Tom Tom
14" x 12" Tom Tom
BC-800W Boom Stand
TH-88S Tom Holder (2)
AX-20 Adapter (2)

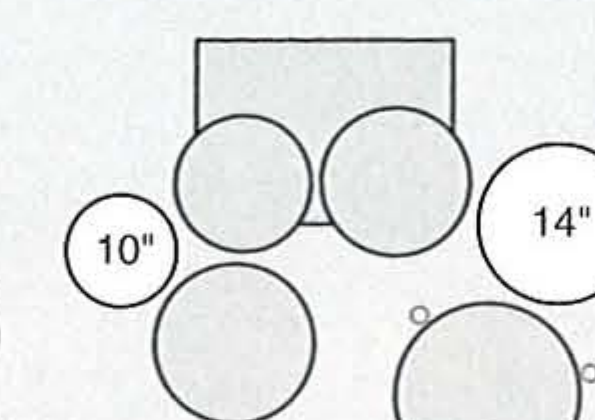

ELX-8
EX-8
22" x 16" Bass
10" x 8" Tom Tom
14" x 14" Floor Tom
BC-800W Boom Stand (2)
P-100 Bass Drum Pedal
TH-881 Tom Holder
HA-100 Hi-Hat Attachment

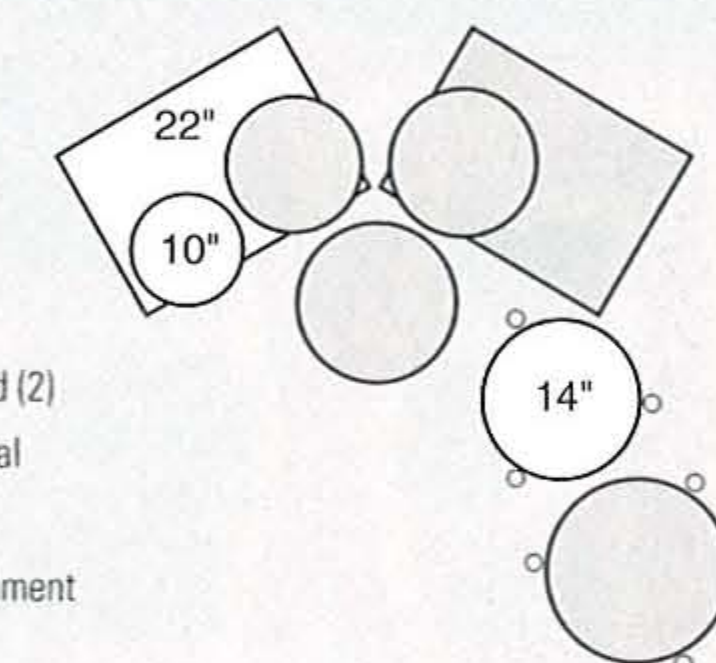

ELX Super High Gloss Lacquer Finish



EX Exclusive Covered Finish



ELX #273 Blue Mist
 Basic Configuration : ELX 825DH
 Options : ELX-6F(ELX1614T, TC-800W), B-800W(2), CH-80, AX-28



EX #50 Mirror Chrome
 Basic Configuration : EX 824D



EX #98 Charcoal Metallic
 Basic Configuration : EX 825
 Options : EX-6(EX1008T, TH-88S, AX-20), CLH-100, CH-80, AX-28(2), B-800W(2), CH-70



FX FORUM

FORUM READY-SET-GO!
IF YOU'RE READY TO ROCK... YOU'RE READY FOR FORUM.

Forum Ready-Set-Go! is the all-in-one concept, that gets you started in style and ready to rock with the least amount of hassle. Forum has it all, plus the quality, the sound...that's genuine Pearl. With Forum Ready-Set-Go you get a complete five piece set of drums, a full set of rugged double braced hardware, a free throne, free cymbals, a free pair of Vic Firth sticks, and even a free video with all the set-up, tuning, and instructional pointers you'll need. Wow! Nobody offers a deal like this. Try buying it all separately and you'll spend hundreds more. For the beginning drummer, nothing offers the inspiration that comes from the sound and feel of a true high quality instrument, and our Forum Series represents the absolute ultimate quality available in its price range.

Pearl's patented Heat Compression Shell Molding System produces the most exacting, best sounding drum shells available on the market today, and all Pearl Drums, from top of the line Masters and totally handmade, completely awesome Masterworks drums, to both Forum and Export Series drums are all made with this exclusive process. Forum also features extremely durable covered finishes in five color choices, a vast array of optional component drums so you can add to your set as your needs change, a matching all wood Snare Drum, tough black carbon steel Bass Drum Hoops, dependable deep gear designed Tom Holders and one of Pearl's highly acclaimed, super fast Bass Drum Pedals.

Forum Ready-Set-Go!
If you're ready to Rock...you're ready for Forum.

FX FORUM SERIES

Shell Material: 6 ply 7.5mm Select Hardwood shells
Finishes: Pearl's exclusive covered finishes



FX 725HC
#98 Charcoal Metallic



FX 725C
#31 Jet Black

FX 725HC

2216B	22"x16"	Bass Drum
1008T	10"x 8"	Tom Tom
1209T	12"x 9"	Tom Tom
1412T	14"x12"	Tom Tom
1455S	14"x5.5"	Snare Drum
CX318CR	18"	Crash-Ride Cymbal
CX314HH	14"(1pr.)	Hi-Hat Cymbals
TH-70 (x2)		Tom Holder
TH-70S		Tom Holder, Short
AX-20		Adapter
H-70W		Hi-Hat Stand
S-70W		Snare Drum Stand
B-70W		Cymbal Boom Stand
P-100		Drum Pedal
D-70W		Drum Throne
Vic Firth	5A	Drumsticks
Video		An Introduction to Drumming featuring ERIC SINGER

FX 725C

2216B	22"x16"	Bass Drum
1210T	12"x10"	Tom Tom
1311T	13"x 11"	Tom Tom
1616F	16"x16"	Floor Tom
1455S	14"x5.5"	Snare Drum
CX318CR	18"	Crash-Ride Cymbal
CX314HH	14"(1pr.)	Hi-Hat Cymbals
TH-70 (x2)		Tom Holder
H-70W		Hi-Hat Stand
S-70W		Snare Drum Stand
B-70W		Cymbal Boom Stand
P-100		Drum Pedal
D-70W		Drum Throne
Vic Firth	5A	Drumsticks
Video		An Introduction to Drumming featuring ERIC SINGER

FX 705C

2016B	20"x16"	Bass Drum
1008T	10"x 8"	Tom Tom
1209T	12"x 9"	Tom Tom
1414F	14"x14"	Floor Tom
1455S	14"x5.5"	Snare Drum
CX318CR	18"	Crash-Ride Cymbal
CX314HH	14"(1pr.)	Hi-Hat Cymbals
TH-70 (x2)		Tom Holder
H-70W		Hi-Hat Stand
S-70W		Snare Drum Stand
B-70W		Cymbal Boom Stand
P-100		Drum Pedal
D-70W		Drum Throne
Vic Firth	5A	Drumsticks
Video		An Introduction to Drumming featuring ERIC SINGER

FX Exclusive Covered Finish



RT RHYTHM TRAVELER

Let your Rhythm Run

The Rhythm Traveler, Pearl's ground-breaking practice/gig kit, now includes a pair of 14" hi-hat and 16" ride cymbal for live playing! Easy to transport and easy to practice without disturbing the neighbours. Rubber cymbal muffers are also provided for near-silent practicing.

RT 705C

20"x 8" Bass Drum, 10"x 5" / 12"x 5" / 14"x 5" Tom Tom, 13"x 5" Wood Snare Drum
CX316C 16" Brass Cymbal, CX314HH 14"(1pr.) Brass Hi-Hats
RP-14C / RP-14B Rubber Cymbal Muffler Pad
10"/12"/14"/20" Clear Heads, 13" Coated Head
TH-70(2), TH-70S, AX-20, C-70W, P-70, H-70W, S-70W



#31 Jet Black #33 Pure White



Muffle Heads (mesh) & Cymbal Muffers for Practicing
Plastic Heads & Real Cymbals for Live Playing





Masterworks snare drums offer you the ultimate choice to design your Snare drum of your dreams. As with all Masterworks drums, you can choose the woods, thickness, size and depth to create a snare drum that is perfect for the style in which you play. You also have the option to choose the type of hoop, lug style, hardware plating, and throw-off.

pearl **snare** drums

Masterworks

Size : 14" x 5.5"
Shell : 6ply Maple
with Burl Mahogany Outer-ply
Hardware : Gold Plated Tube Lugs,
SuperHoop II's and SR-017 Strainer



Red Burl Mahogany



Rootbeer Fade

Size : 14" x 4"
Shell : 6ply All Maple
Hardware : Gold Plated CL-05 Lugs,
MasterCast Hoops and SR-018 Strainer

Size : 14" x 5.5"
Shell : 8ply Maple
with 2ply Mahogany Inner-ply
Hardware : Chrome Plated Bridge Lugs,
MasterCast Hoops, and SR-017 Strainer



Silver Micro Flake



Natural Buginga

Size : 14" x 5.5"
Shell : 6ply Birch
with Buginga Outer-ply
Hardware : Gold Plated Bridge Lugs,
MasterCast Hoops and SR-017 Strainer

Size : 14" x 6"
Shell : 4ply Mahogany
with Burl Mahogany Outer-ply
Hardware : Chrome Plated Bridge Lugs,
SuperHoop II's and SR-015 Strainer



Natural Burl Mahogany



Gun Metal Blue

Size : 14" x 5.5"
Shell : 6ply Maple
with 2ply Mahogany Inner-ply
Hardware : Black Chrome Plated Bridge Lugs,
MasterCast Hoops and SR-017 Strainer

Size : 14" x 4"
Shell : 4ply Maple
with Tamo Outer-ply
Hardware : Chrome Plated CL-05 Lugs,
SuperHoop II's and SR-018 Strainer



Natural Tamo



Antique White

Size : 14" x 6.5"
Shell : 4ply All Birch
Hardware : Chrome Plated CL-100 Lugs,
MasterCast Hoops and SR-015 Strainer

Size : 14" x 6.5"
Shell : 10ply All Maple
Hardware : Chrome Plated CL-100 Lugs,
MasterCast Hoops and SR-015 Strainer



Brown Sparkle



Purple Marbleized

Size : 14" x 5.5"
Shell : 4ply Maple
with 2ply Mahogany Inner-ply
Hardware : Black Chrome Plated Bridge Lugs,
MasterCast Hoops and SR-017 Strainer

Size : 14" x 6.5"
Shell : 4ply Maple
with Outer/Inner Carbon Fiber
Hardware : Black Chrome Plated Bridge Lugs,
MasterCast Hoops and SR-015 Strainer



Carbon Fiber



Carbon Fiber

Size : 14" x 5.5"
Shell : 4ply Maple
with Outer/Inner Carbon Fiber
Hardware : Chrome Plated Bridge Lugs,
MasterCast Hoops and SR-017 Strainer

Masters

Masters snare drums features 4 types of shells, MasterCast Hoops, Stainless Steel Tension Rods, and now available in 4 different colors of hardware. MMX Masters Custom feature 4 ply maple shell with 4 ply reinforcement rings which gives you a warm rich tone and are very responsive. MRX Masters Custom feature thicker 6 ply maple shells producing an extra volume and incredible projection. BRX Masters Studio feature 6 ply birch shells producing crisper...almost "metal-like"...highs for real presence and articulation. MHX Masters Mahogany Classic snare drums feature 4 ply African Mahogany shells with 4 ply maple rings. The Mahogany shells produce the richest and deepest sound.

* w/4 ply Maple glue rings

6 ply Maple



	MRX1465S	MRX1455S
Size (Dia. x Depth)	14" x 6.5"	14" x 5.5"
Shell	6 ply Maple	6 ply Maple
Hoops	Master Cast (DC1410/DC1410S)	Master Cast (DC1410/DC1410S)
Lugs	CL-65	CL-55
Rods	10	10
Tension Rods	SST-5047	SST-5052
Strainer	SR-015	SR-015
Snares	S-022N	S-022N

4 ply Maple



	MMX1465SD	MMX1465S	MMX1455S
Size (Dia. x Depth)	14" x 6.5"	14" x 6.5"	14" x 5.5"
Shell	4 ply Maple*	4 ply Maple*	4 ply Maple*
Hoops	Master Cast (DC1410/DC1410SG)	Master Cast (DC1410/DC1410S)	Master Cast (DC1410/DC1410S)
Lugs	CL-100	CL-65	CL-55
Rods	10	10	10
Tension Rods	SST-5047	SST-5047	SST-5052
Strainer	SR-015	SR-015	SR-015
Snares	S-030N	S-022N	S-022N

6 ply Birch



	BRX1465S	BRX1455S
Size (Dia. x Depth)	14" x 6.5"	14" x 5.5"
Shell	6 ply Birch	6 ply Birch
Hoops	Master Cast (DC1410/DC1410S)	Master Cast (DC1410/DC1410S)
Lugs	CL-65	CL-55
Rods	10	10
Tension Rods	SST-5047	SST-5052
Strainer	SR-017	SR-017
Snares	S-022N	S-022N

4 ply African Mahogany



	MHX1465S	MHX1455S
Size (Dia. x Depth)	14" x 6.5"	14" x 5.5"
Shell	4 ply African Mahogany*	4 ply African Mahogany*
Hoops	Master Cast (DC1410/DC1410S)	Master Cast (DC1410/DC1410S)
Lugs	CL-65	CL-55
Rods	10	10
Tension Rods	SST-5047	SST-5052
Strainer	SR-017	SR-017
Snares	S-022N	S-022N

Matching Pearl Drum Kit Snare Drums

SRX Session Custom series kits feature a 6 ply maple shell snare drum, and are available in two sizes. ELX Export series kits feature a 6 ply Mahogany shell snare drum, and offer the same matched lacquer finishes as the kits. EX Export series kits and FX Forum series kits feature a 6 ply Mahogany shell snare drum, and are available in the same color choices as the kits.

Session Custom

Session Custom



	SRX1465S	SRX1455S
Size (Dia. x Depth)	14" x 6.5"	14" x 5.5"
Shell	6 ply Maple	6 ply Maple
Hoops	SuperHoop II (SH1408B/SH1408S)	SuperHoop II (SH1408B/SH1408S)
Lugs	CL-65	CL-55
Rods	8	8
Tension Rods	T-061L	T-062
Strainer	SR-017	SR-017
Snares	S-022N	S-022N

Export Select

Export

Forum

Standard Steel



	ELX1455S	EX1455S	FX1455S	SS1455
Size (Dia. x Depth)	14" x 5.5"	14" x 5.5"	14" x 5.5"	14" x 5.5"
Shell	6 ply Mahogany	6 ply Mahogany	Mahogany	Steel
Hoops	1.6mm Steel (RIM1408B/1408S)	1.6mm Steel (RIM1408B/1408S)	1.6mm Steel (RIM1408B/1408S)	1.6mm Steel (RIM1408B/1408S)
Lugs	CL-50	CL-50	SL-03	CL-50
Rods	8	8	8	8
Tension Rods	T-062	T-062	T-062	T-062
Strainer	SR-014N	SR-014N	SR-013	SR-014N
Snares	S-022	S-022	S-022	S-022

SensiTone

SensiTone Snare Drums feature beaded shells in either brass or steel and we have now extended the range with our vintage style SensiTone Classic II drums, available in either black nickel or Chrome plating. SensiTone snare drums have amazing sensitivity as well as excellent attack, projection and tonal clarity. The drums are available in a variety of sizes and all feature our 2.3mm SuperHoop II's*, and fully adjustable SR-017 strainer systems.

* The SCB1450B features MasterCast die cast hoops.

SensiTone Classic II



	SCB1450B	SCS1450
Size (Dia. x Depth)	14" x 5"	14" x 5"
Shell	Beaded Brass, Black Nickel Plated.	Beaded Steel
Hoops	Master Cast (DC1410/DC1410S)	SuperHoop II (SH1410B/1410S)
Lugs	TB-50	TB-50
Rods	10	10
Tension Rods	SST-5042	SST-5042
Strainer	SR-017	SR-017
Snares	S-022N	S-022N

SensiTone Custom Alloy



	STB1465	STB1455	STS1465	STS1455	STS1355	STS1250
Size (Dia. x Depth)	14" x 6.5"	14" x 5.5"	14" x 6.5"	14" x 5.5"	13" x 5.5"	12" x 5"
Shell	Beaded Brass	Beaded Brass	Beaded Steel	Beaded Steel	Beaded Steel	Beaded Steel
Hoops	SuperHoop II (SH1410B/1410S)	SuperHoop II (SH1410B/1410S)	SuperHoop II (SH1410B/1410S)	SuperHoop II (SH1410B/1410S)	SuperHoop II (SH1308B/1308S)	SuperHoop II (SH1208B/1208S)
Lugs	CL-65	CL-55	CL-65	CL-55	CL-55	CL-55
Rods	10	10	10	10	8	8
Tension Rods	SST-5047	SST-5052	T-061L	T-062	T-062	T-062
Strainer	SR-017	SR-017	SR-017	SR-017	SR-017	SR-017
Snares	S-022N	S-022N	S-022N	S-022N	S-029N	S-031N

Soprano

Popcorn

Soprano

Piccolo

Piccolo

Piccolo

Piccolo

Effect

Pearl's Snare Drum Line up includes a variety of effect snare drums. Sopranos (10"x4" and 12"x7"), Popcorn (10"x6"), and Piccolos (14"x4" and three 13"x3" models) are available.



	M1040	M1060	M1270	M1330	B1330	S1330B	M1440
Size (Dia. x Depth)	10" x 4"	10" x 6"	12" x 7"	13" x 3"	13" x 3"	13" x 3"	14" x 4"
Shell	6 ply Maple	6 ply Maple	8 ply Maple	6 ply Maple	Brass	Steel	6 ply Maple
Hoops	1.6mm Steel (RIM1006/1006SL) w/L.S.S.	SuperHoop II (SH1006/1006S)	1.6mm Steel (RIM1208B/1208S)	1.6mm Steel (RIM1308B/1308S)	1.6mm Steel (RIM1308B/1308S)	1.6mm Steel (RIM1308B/1308S)	1.6mm Steel (RIM1410B/1410S)
Lugs	CL-05	CL-65	CL-100	CL-05	CL-05	CL-05	CL-05
Rods	6	6	8	8	8	8	10
Tension Rods	SST-5038	SST-5035	SST-5047	T-055	T-055	T-055	SST-5042
Strainer	SR-018	SR-018	SR-018	SR-018	SR-018	SR-018	SR-018
Snares	S-032N	S-032N	S-031N	S-029N	S-029N	S-029N	S-022N

UltraCast

UltraCast is our exclusive precision milled, cast aluminum shell snare drum which are finished in a special black lacquered coating. Aluminum is a relatively soft metal and provides the warm, round, full bodied tone of a wood shell snare, but you also get the crack, volume and projection of metal snare. Its bearing edges are precision cut and perfect every time so that they provide ease of tuning and perfect head seating. UltraCast also features tube lugs, Stainless steel tension rods, ultra-sensitive S-022NU snares and SuperHoop II rims.



	UCA1465	UCA1450
Size (Dia. x Depth)	14" x 6.5"	14" x 5"
Shell	3mm Cast Aluminum	3mm Cast Aluminum
Hoops	SuperHoop II (SHB1410B/1410S)	SuperHoop II (SHB1410B/1410S)
Lugs	TB-65B	TB-50B
Rods	10	10
Tension Rods	SST-5042	SST-5042
Strainer	SR-017B	SR-017B
Snares	S-022NU	S-022NU

Free Floating System

Pearl's patented "Free Floating" concept is designed to allow the shell to resonate freely by removing all hardware from contact with the shell. All the Snare Drums now feature solid steel tension rod receivers for 100% pull-out-proof dependability.

"FFS" Snare Drums are available in four distinctive shell materials : Copper, Brass, and 6 ply 100% aged premium Maple featuring MasterCast die cast hoops for intense rimshots and incredible focus, and also a steel shell featuring SuperHoop II 2.3mm steel hoops. All shells are available in 3 shell depths; 3", 5" or 6.5"

Shell	6 ply Maple	Brass	Copper
Size (Dia. x Depth) 14" x 6.5"			
Hoops Master Cast (DC1410/DC1410SG)			
Lugs FT-65*			
Rods 10			
Tension Rods SST-5042			
Strainer SR-010			
Snares S-025			
			
	FM1465	FB1465	FC1465

Size (Dia. x Depth) 14" x 5"			
Hoops Master Cast (DC1410/DC1410SG)			
Lugs FT-50*			
Rods 10			
Tension Rods SST-5042			
Strainer SR-010			
Snares S-025			
			
	FM1450	FB1450	FC1450

Size (Dia. x Depth) 14" x 3.5"			
Hoops Master Cast (DC1410/DC1410SG)			
Lugs FT-35*			
Rods 10			
Tension Rods SST-5035			
Strainer SR-010			
Snares S-025			
			
	FM1435	FB1435	FC1435

Shell	Steel
Size (Dia. x Depth) 14" x 3.5"	
Hoops 1.6mm Steel (RIM1410B/1410SG)	
Lugs FT-35*	
Rods 10	
Tension Rods T-060	
Strainer SR-010	
Snares S-025	
	
	FS1435B

Signature Series

Pearl continues to expand its snare line-up with input from some of the most dynamic drummers of our time. For 2002, we're offering the Tico Torres Signature Snare Drum, the Ian Paice Signature Snare Drum, and the Eric Singer Signature Snare Drum. All models are equipped with Precision-Fit Stainless Steel Tension Rods.

Ian Paice

Deep Purple's legendary drummer designed this snare drum to have classic looks, classic sound but with a modern specification. The 6.5" steel shell will give you big rock sound and the locking nuts will help your drum to "stay tuned all night".



IP1465
 Size (Dia. x Depth) : 14" x 6.5"
 Shell : Beaded Steel
 Hoops : SuperHoop II (SH1410B/1410S)
 Lugs : TB-65
 Rods : 10
 Tension Rods : SST-5042
 Strainer : SR-017
 Snares : S-022N

Tico Torres

After decades of international success with Bon Jovi, Tico Torres worked with the Pearl design team and choose a cast aluminium shell to achieve a sound which has the warmth of a wood drum yet still has the bite of a metal drum.



TR1465
 Size (Dia. x Depth) : 14" x 6.5"
 Shell : 3mm Cast Aluminium
 Hoops : Master Cast (DC1410/DCS1410SG)
 Lugs : FT-65
 Rods : 10
 Tension Rods : SST-5042
 Strainer : SR-010
 Snares : S-025

Eric Singer

Eric has excelled in the most extreme musical situations and played for Kiss as well as Alice Cooper. His signature snare drum is designed to give you more projection and depth using our thickest drum shell (10 plies of aged 100% maple) and it has a unique penetrating sound.



ES1465
 Size (Dia. x Depth) : 14" x 6.5"
 Shell : 10 ply Maple
 Hoops : Die Cast (DC1410/DC1410S)
 Lugs : CL-65
 Rods : 10
 Tension Rods : SST-5047
 Strainer : SR-017
 Snares : S-022N
 Color : #160 Silver Sparkle

Dennis Chambers

As one of the world's most respected International session musicians and clinician, Dennis's signature snare drum has outstanding sound and tonal dynamics. This top specification drum includes a wide range of features to help you achieve the perfect sound.



DC1465
 Size (Dia. x Depth) : 14" x 6.5"
 Shell : 4 ply Maple w/4 ply Maple glue rings
 Hoops : Die Cast (DC1410/DC1410S)
 Lugs : CL-100
 Rods : 10
 Tension Rods : SST-5047
 Strainer : SR-020 x 2
 Snares : S-030N
 Head : Evans B-14GIRB /S-14H30
 Color : #136 Opal White

Omar Hakim

Having played the drums for Sting, Madonna and David Bowie, to name but a few, Omar was looking for a unique sound in designing his signature snare drum. The 13 x 5 shell has a power piccolo sound while the Mahogany helps to produce the perfect blend of sonic power, projection and tonal colour.



OH1350
 Size (Dia. x Depth) : 13" x 5"
 Shell : 6 ply African Mahogany
 Hoops : SuperHoop II (SH1308B/1308S)
 Lugs : CL-55
 Rods : 8
 Tension Rods : SST-5047
 Strainer : SR-015
 Snares : S-029N
 Color : #140 Natural Mahogany

Chad Smith

Loud, Loud and louder... What else would expect Chad Smith to sound like in the Red Hot Chili Peppers. This awesome rock drum looks as good as it sounds and produces consistently, one of the best, overall rock drum sounds in the world today.



CS1450
 Size (Dia. x Depth) : 14" x 5"
 Shell : Steel, Black Nickel Plated
 Hoops : SuperHoop II (SH1410B/1410S)
 Lugs : CL-55
 Rods : 10
 Tension Rods : SST-5047
 Strainer : SR-015
 Snares : S-022

Steve Ferrone

Tasteful musicality and powerful groove...the trademarks of Steve's sound...that why he's the first call for superstars such as Eric Clapton and Tom Petty. His signature snare drum is a reflection of the maestro's playing style; tasteful and elegant, yet powerful on demand.



SF1465
 Size (Dia. x Depth) : 14" x 6.5"
 Shell : Beaded Brass, Black Nickel Plated
 Hoops : SuperHoop II (SHG1410B/SHG1410S)
 Lugs : Tube (TB-65 CG)
 Rods : 10
 Tension Rods : SST-5042
 Strainer : SR-017CG
 Snares : S-022N

Marvin " Smitty " Smith

Playing on the Tonight show as well as Branford Marsalis and Sting, Marvin needed a drum that could accommodate a range of diverse musical styles. By using a Copper shell, this drum helps to control overtones and still retain the brightness and punch of a metal drum.



MS1440
 Size (Dia. x Depth) : 14" x 4"
 Shell : Copper
 Hoops : SuperHoop II (SHG1410B/SHG1410S)
 Lugs : CL-05G
 Rods : 10
 Tension Rods : SST-5042
 Strainer : SR-018G
 Snares : S-022N



Drum Pedals PowerShifter Eliminator

Pearl's original PowerShifter pedal took the drumming world by storm soon after its release in 1996. Never before had a pedal offered such speed, power and smoothness, combined with the unheard ability to perfectly custom tailor the feel of the pedal specifically to each player's needs. The PowerShifter function was revolutionary, with no pedal before or since offering this amount of total control...until now. Introducing the PowerShifter Eliminator from Pearl. If our original PowerShifter pedal was revolutionary, the Eliminator is simply extraordinary in every way. The PowerShifter Eliminator features our exclusive Interchangeable Cam System, providing 4 completely different drive cams from which to choose. From radically aggressive power to maximum finesse, and every nuance in between, one push of a button is all it takes to change from one cam to the next. This incredible Cam System effortlessly meets the needs of any player and any style of music. After choosing a cam, our PowerShifter function then allows you to move the footboard to further fine tune the feel and power of the pedal. PowerShifter Eliminator is available with your choice of either dual chain or belt drive systems. For players that prefer a belt drive over chain, PowerShifter Eliminator offers a belt drive model that features an extremely strong, highly durable drive belt for a super smooth, solid feel, that no other pedal can match. With all these available options, any player can easily custom configure the pedal of their dreams.

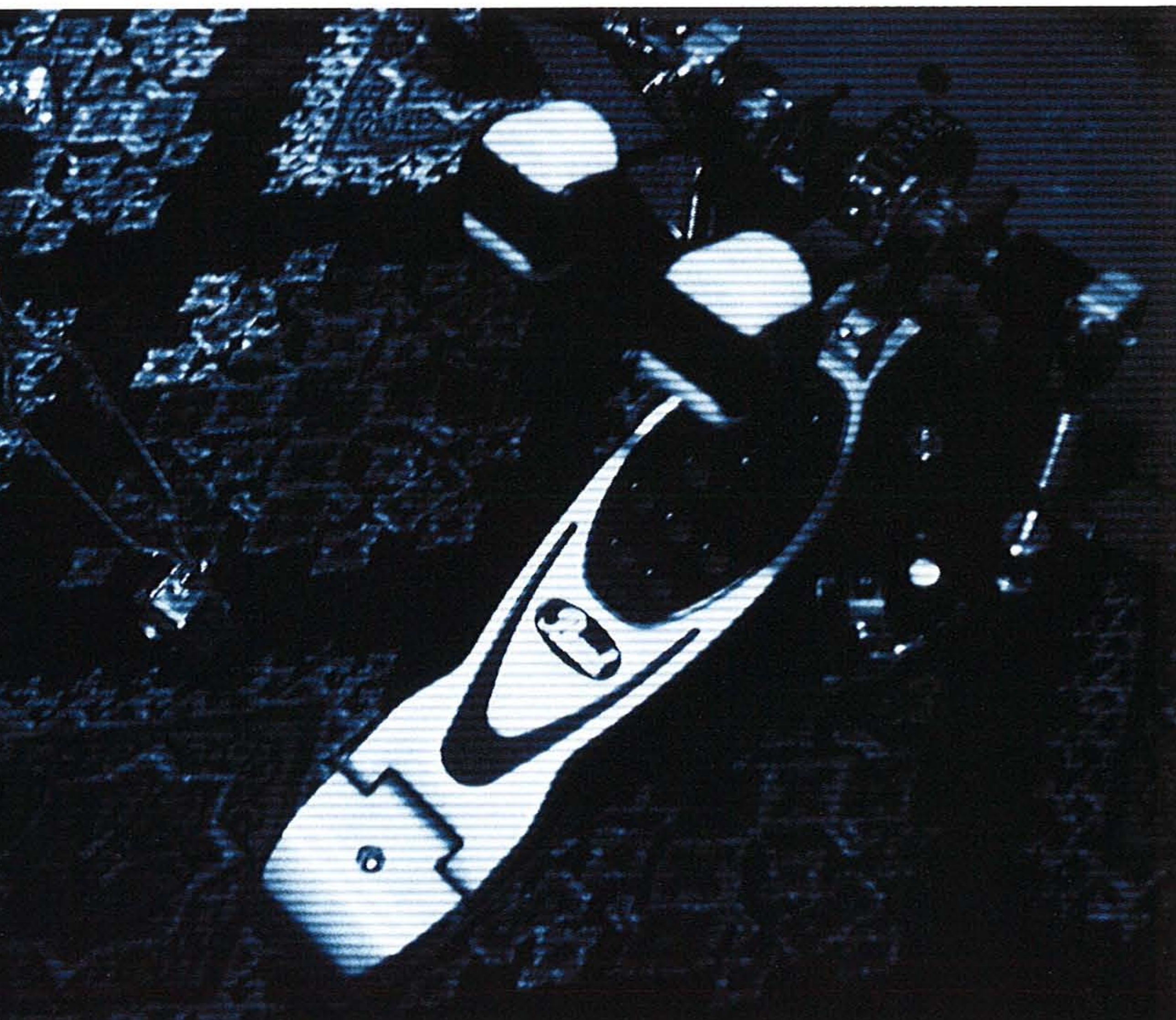

- Interchangeable Cam System
- Wide Tension-Range Spring
- PowerShifter function
- Exclusive Footboard design
- NEW Precision Hinges
- Traction Plate with Traction Grips
- Quad Beater
- Floating Spring Pendulum
- Infinite Beater Angle with gauge
- Adjustable Height Footboard
- Adjustable Roller Cam Hoop Clamp
- Power Plate



CHAIN DRIVE Pedal
P-2000C



BELT DRIVE Pedal
P-2000B



Chain Drive

Pearl's double chain drive glides silently within the cam channel providing a super smooth, quiet, powerful precision feel. Since there are no sprockets involved, there is much less wear on the chain and less noise in the studio.



Belt Drive

Our Belt Drive provides a very comfortable, natural feel very similar to a direct drive system. We use an extremely strong, highly durable drive belt, instead of a normal rubber strap, to provide maximum durability, strength, and stretch resistance.

- The Black Cam is factory installed on P-2000C PowerShifter Eliminator Chain Drive Pedals. In addition, three other cams : White, Blue, and Red are included.
- The Red Cam is factory installed on P-2000B PowerShifter Eliminator Belt Drive Pedals. In addition, three other cams : Black, White, and Blue are included.



CHAIN DRIVE Double Pedals
P-2002C



BELT DRIVE Double Pedals
P-2002B

- Interchangeable Cam System
- Wide Tension-Range Springs
- PowerShifter function
- Exclusive Footboard design
- New Precision Hinges
- Traction Plate with Traction Grips on both pedals
- Quad Beaters
- Floating Spring Pendulum
- Infinite Beater Angle with gauge
- Adjustable Height Footboards
- Adjustable Roller Cam Hoop Clamp
- Power Plate
- Aircraft Quality Aluminum Drive Shaft
- New Stainless Steel Universal Joints

- The Black Cams are factory installed on P-2002C PowerShifter Eliminator Chain Drive Double Pedals. In addition, White x 2, Blue x 2, and Red x 2 Cams are included.
- The Red Cams are factory installed on P-2002B PowerShifter Eliminator Belt Drive Double Pedals. In addition, Black x 2, White x 2, and Blue x 2, Cams are included.



Stainless Steel Universal Joint

(Double pedal Only)

All Pearl Eliminator double pedals now are standard with Stainless Steel Universal Joints featuring ultra-precise tolerances for accurate and lag-free play. The durability of stainless steel is legendary but we've gone further and made the walls 20% thicker to boot for bullet proof dependability you can rely on ggg, after gig, after gig....

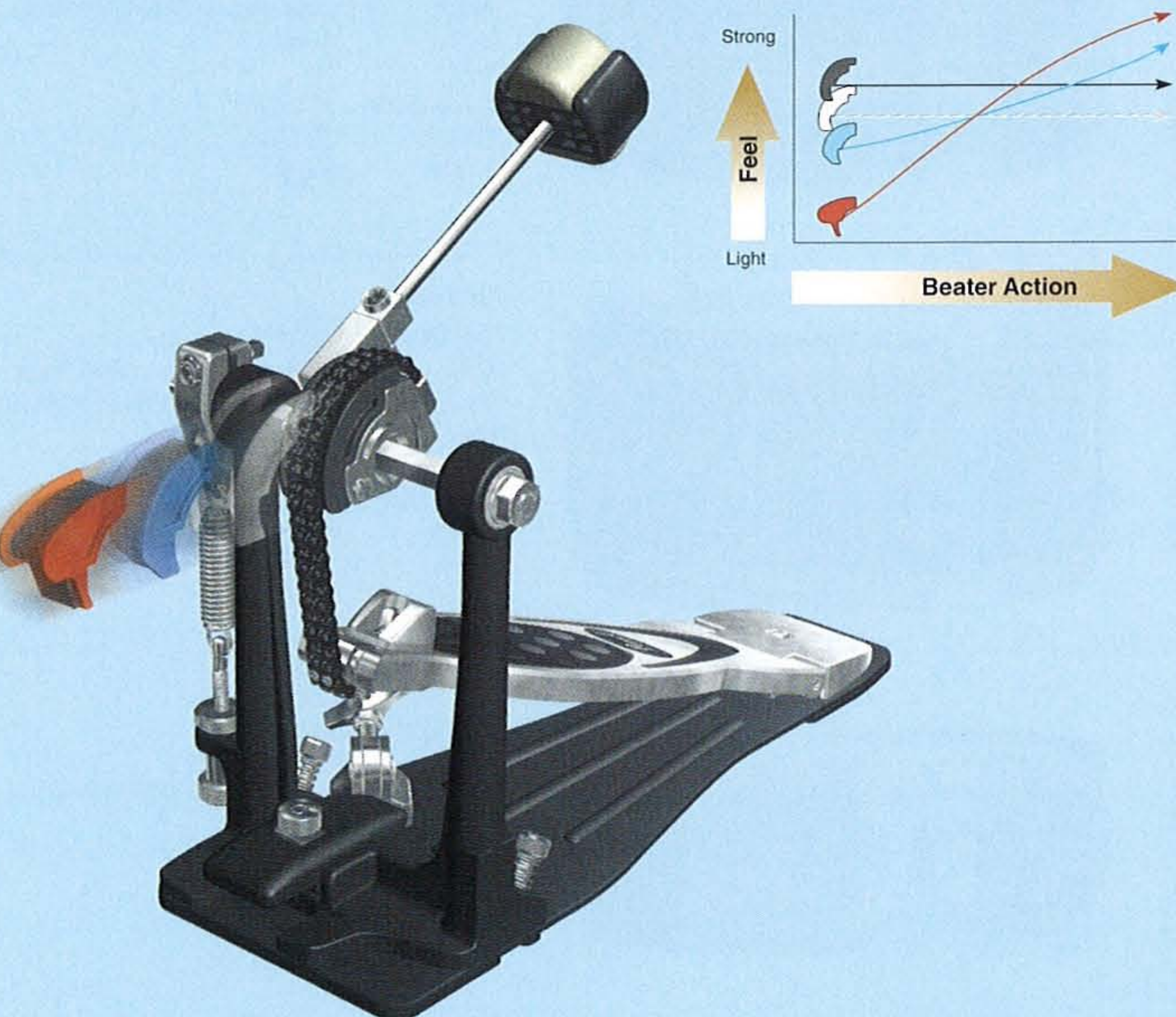

Interchangeable Cam System (US.PAT.6172291)

Our exclusive Cam System provides four interchangeable color coded cams allowing you to quickly change the power and feel of the pedal to suit your individual playing needs. Changing from cam to cam is as simple as pushing the release button and snapping another cam in place.

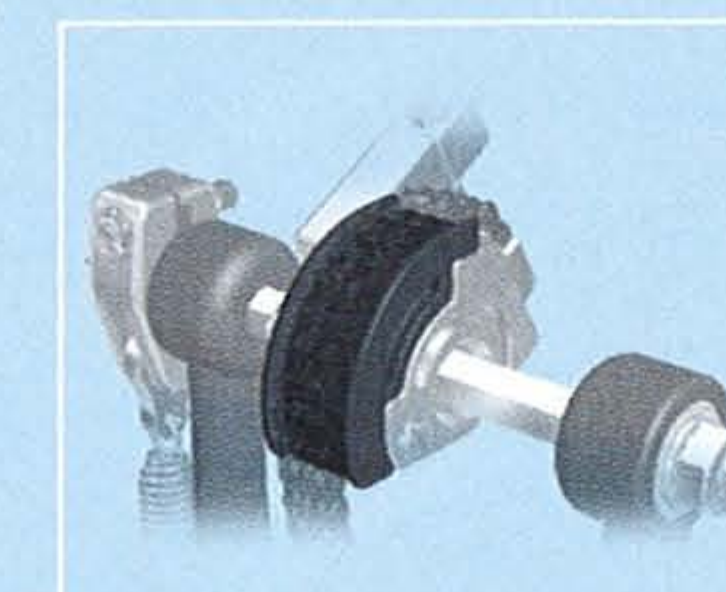

Black

Linear Action Cam
This is Pearl's original sized "perfect circle" Cam design. It offers superior power and a very natural, perfectly well-balanced action and smooth feel.



Blue

Progressive Cam
This is the very popular "off-center" axis type cam design. It offers a lighter feel in the beginning that accelerates with speed and power upon impact.

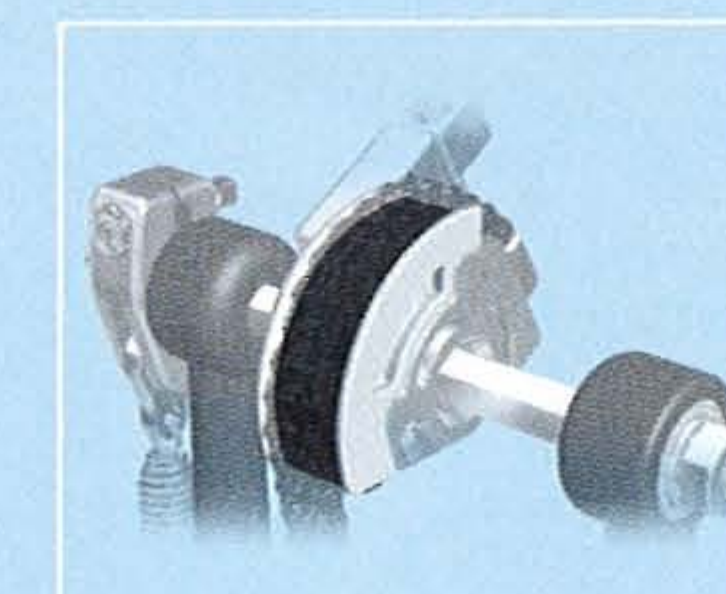

White

Oversized Linear Cam
The White Cam is a slightly over sized "perfect circle" Cam. It offers a very natural, smooth action, with great power and balance, with a slightly lighter pedal feel.



Red

Radical Progressive Cam
The Red Cam features an extreme "off-center" axis design. It provides traditional action with great response to sensitive footwork and extreme power upon impact.

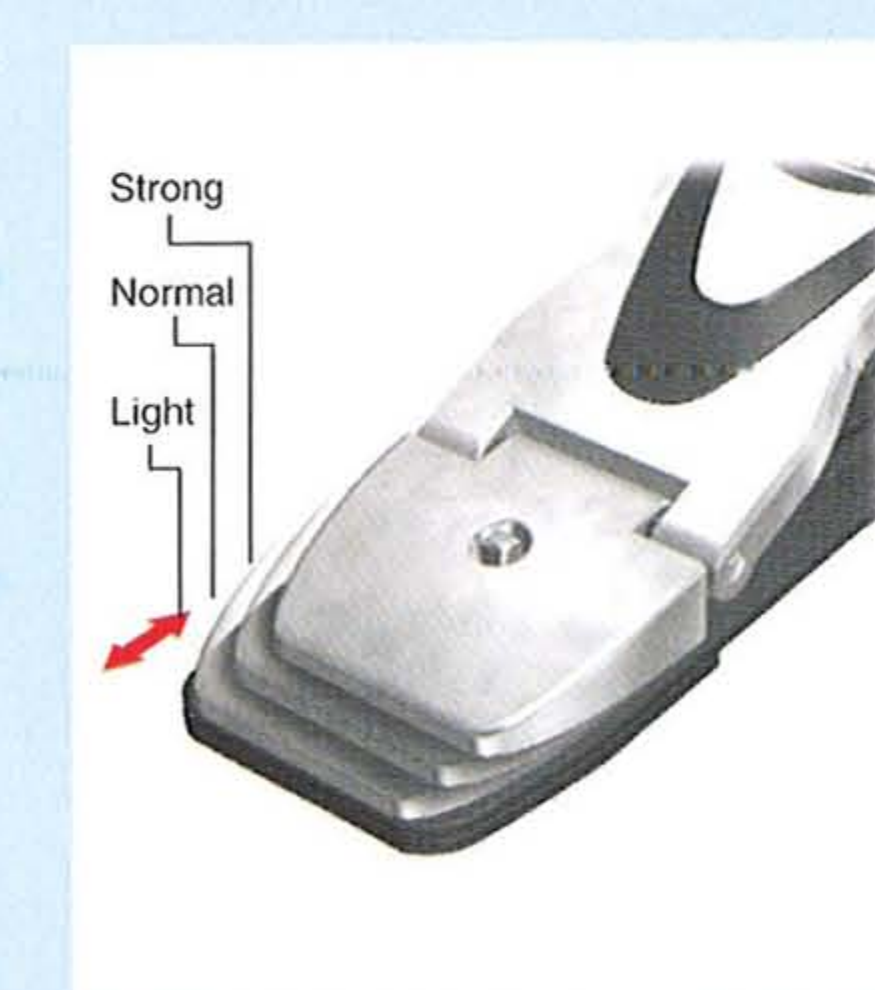

PowerShifter Function

Our revolutionary PowerShifter function provides 3 positions to fine tune the power and feel of the pedal. By moving the footboard forward or back you change the chain or belt drive angle, thus changing the leverage to create a light, normal or strong feel. (US.PAT. 5574237)



Footboard Adjustment

Footboard angle is easily adjusted completely independent of beater angle allowing you to further fine tune the feel and action of your pedal.



Independent Traction Grips

Power Shifter Eliminator's Traction Plate footboard insert allows you to remove and reconfigure each individual traction grip to suit your exact playing requirements. From maximum grip to full slide, and every option in between, the choice is yours. The Traction Plate also reverses to focus the slide or grip surfaces to either the toe or heel of the pedal.



Roller Cam Hoop Clamp

Our redesigned Roller Cam Hoop Clamp multiplies each turn of the adjustment knob to speed the process of attaching the pedal to the hoop. It fits an extremely wide range of hoop thicknesses and offers the smoothest, most secure grip possible.

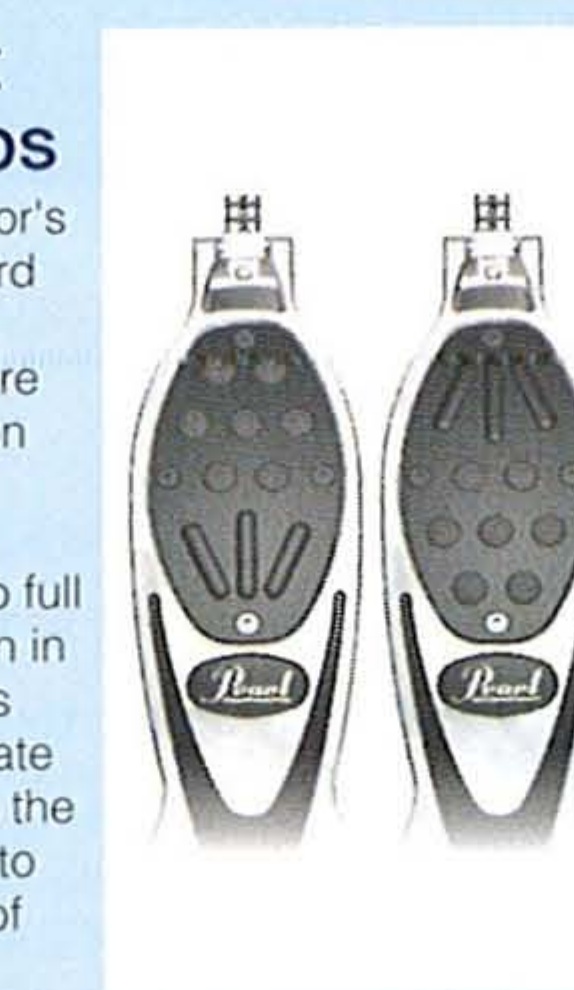

Exclusive Footboard Design

Our exclusive Footboard design offers perfect balance, great stability and extreme player comfort. By redesigning every aspect of the footboard, including spring tension, beater weight and pedal shape, we have created the most powerful feeling Bass Drum Pedal available.

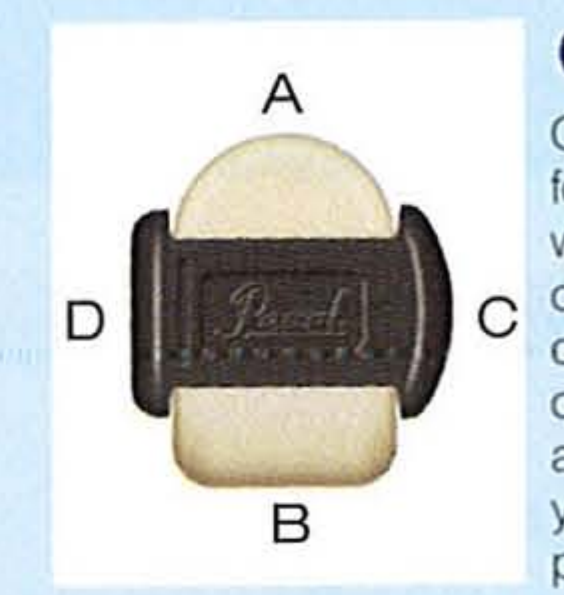

Quad Beater

Our original Quad Beater provides four different beater surfaces, each with its own distinct sound. You can choose from 2 hard plastic surfaces or 2 felt surfaces and either pinpoint or line contact with the head. You also have a sliding memory lock so you will always remember your perfect set-up. (US.PAT. 5610351)

- A: Face : Felt. Contact area : Spot. Sound : Warm with Sharp Attack
- B: Face : Felt. Contact area : Line. Sound : Warm with Dull Attack
- C: Face : Plastic. Contact area : Spot. Sound : Hard with Sharp Attack
- D: Face : Plastic. Contact area : Line. Sound : Hard with Dull Attack



Wide Tension-Range Spring

Our counter spring has been designed to perfectly compliment the weight and balance of the footboard and beater assembly. It also offers a much wider range of adjustability allowing you to fine tune the pedal tension to suit your playing style.



Uni-pressure Spring Clamp

Our Uni-Pressure Spring Clamp System grips a full 360 degrees and allows infinite beater angle adjustments. Featuring a unique Floating Spring Pendulum design that is perfectly centered on the clamp, this system offers full precision bearing movement for unmatched smoothness.

Drum Pedals

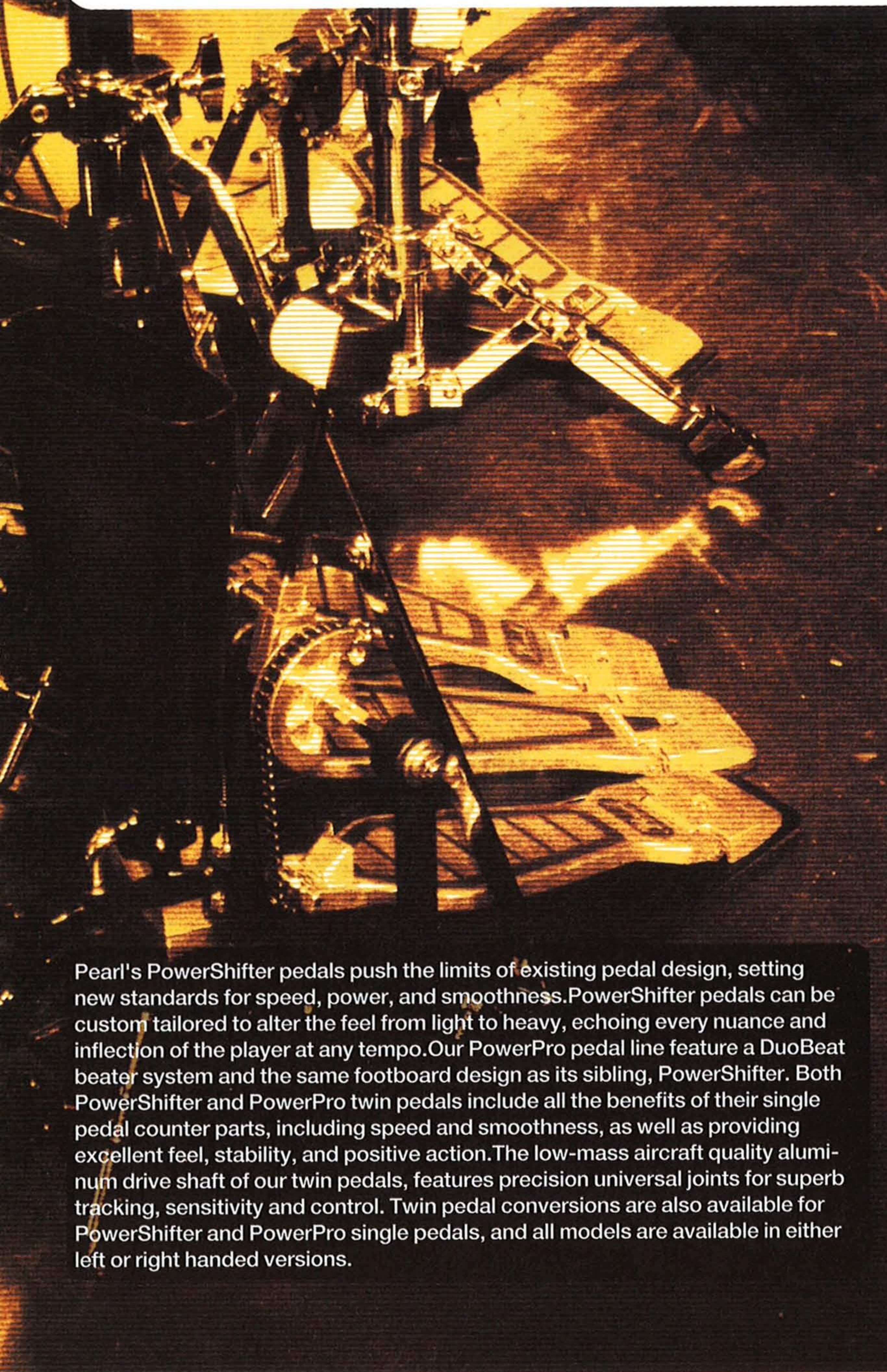

Pearl's PowerShifter pedals push the limits of existing pedal design, setting new standards for speed, power, and smoothness. PowerShifter pedals can be custom tailored to alter the feel from light to heavy, echoing every nuance and inflection of the player at any tempo. Our PowerPro pedal line feature a DuoBeat beater system and the same footboard design as its sibling, PowerShifter. Both PowerShifter and PowerPro twin pedals include all the benefits of their single pedal counter parts, including speed and smoothness, as well as providing excellent feel, stability, and positive action. The low-mass aircraft quality aluminum drive shaft of our twin pedals, features precision universal joints for superb tracking, sensitivity and control. Twin pedal conversions are also available for PowerShifter and PowerPro single pedals, and all models are available in either left or right handed versions.

Power Shifter

Our revolutionary PowerShifter function is a major advancement in pedal technology. By "shifting" the footboard forward or back, the leverage and thus the feel of the pedal is altered from light, medium, and heavy to suit your personal playing style. (US.PAT. 5574237)

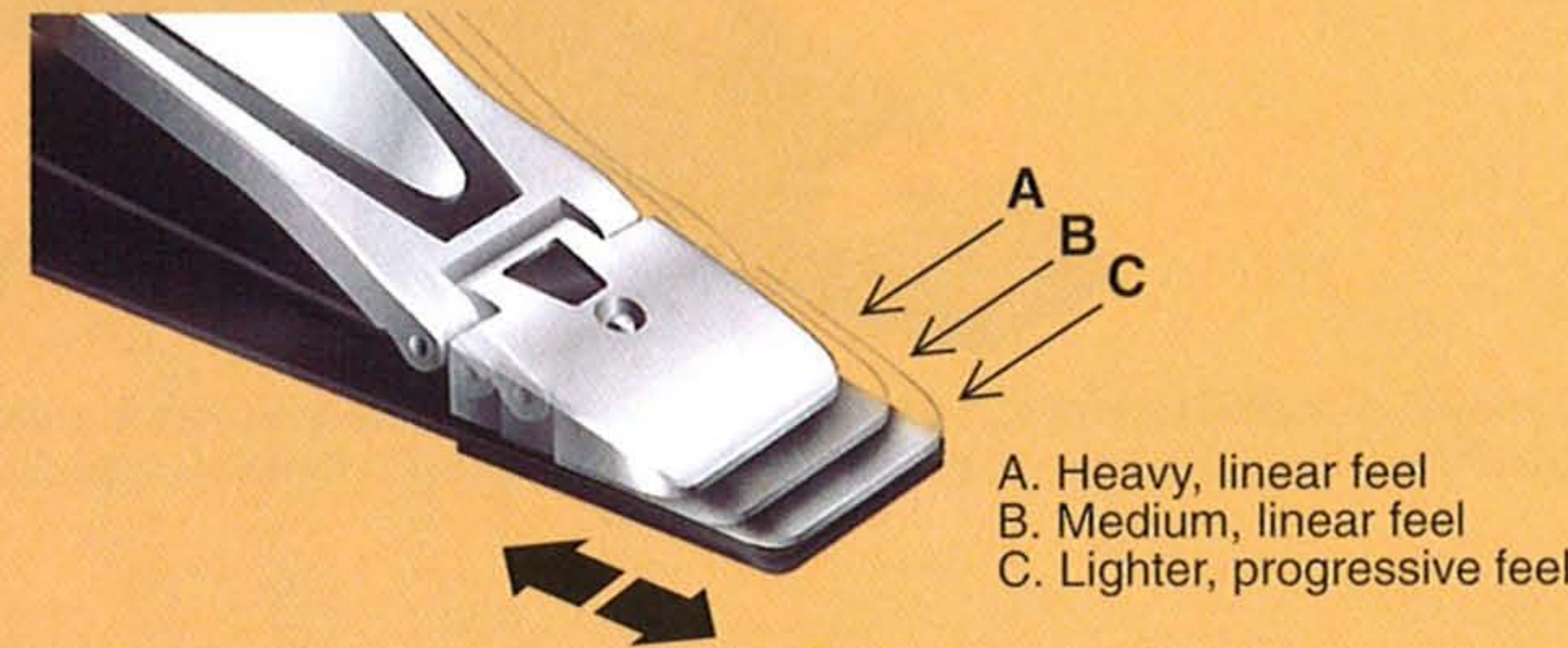

Uni-Pressure Spring Clamp

Floating Spring Pendulum

The spring is attached directly in-line with the rocker cam (not off to the side) for maximum efficiency. The integrated spring roller features precision needle bearings and contributes to the Power Shifter/Power Pro's extraordinary smoothness and incredible speed. The spring is dampened with felt to assure silent action in all playing situations.

Power Shifter

Solid Steel Power Plate

The Power Plate adds rigidity and stability to focus 100% of your energy into the bass drum.

Roller Cam Hoop Clamp System

Quad Beater

Footboard Angle Adjustment

Super Quiet Chain Channel

All Pearl chain drive pedals feature toothless cams with felt-lined channels for efficient power transfer and totally silent operation, a must for recording. Single and double chain versions are available.

Easy Adjustable Spring Tension Knob

Our oversize spring tension knobs provide solid grip and easy adjustment without tools.

PowerShifter

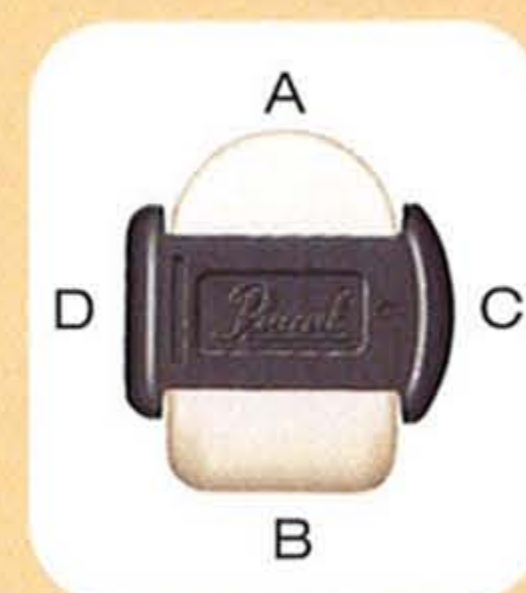

Quad Beater

Our original Quad Beater provides four different beater surfaces, each with its own distinct sound. You can choose from 2 hard plastic surfaces or 2 felt surfaces and either pinpoint or line contact with the head. You also have a sliding memory lock so you will always remember your perfect set-up. (US.PAT. 5610351)

- A.Face : Felt. Contact area : Spot. Sound : Warm with Sharp Attack
- B.Face : Felt. Contact area : Line. Sound : Warm with Dull Attack
- C.Face : Plastic. Contact area : Spot. Sound : Hard with Sharp Attack
- D.Face : Plastic. Contact area : Line. Sound : Hard with Dull Attack

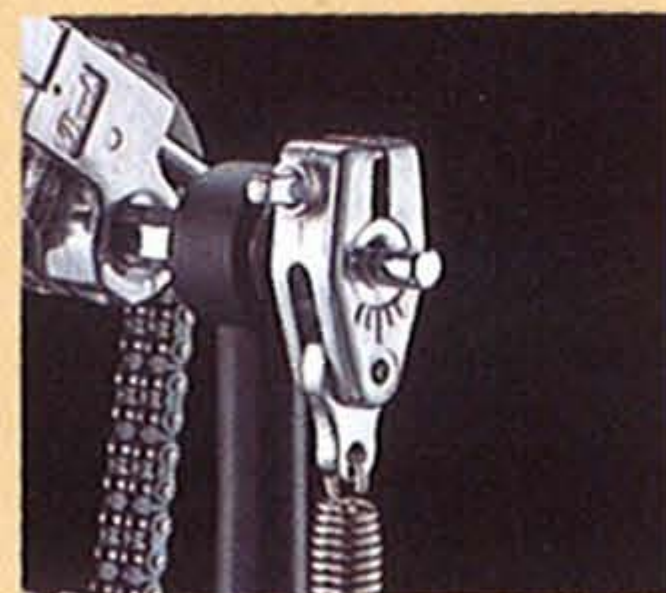

Uni-Pressure Spring Clamp

The Uni-Pressure Spring Clamp provides infinite beater angle adjustment for perfect stroke length and balance without changing spring tension.

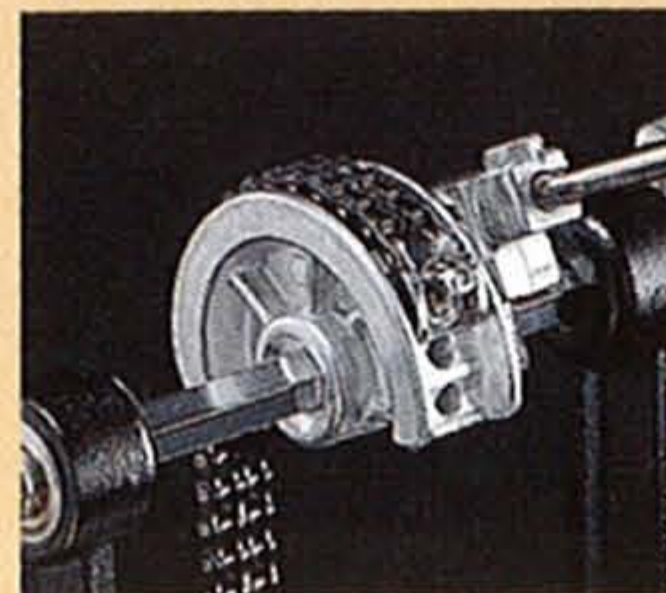

Footboard Angle Adjustment

The chain on the P-201P adjusts to three positions to customize the footboard angle to your individual playing style without changing beater angle and spring tension.

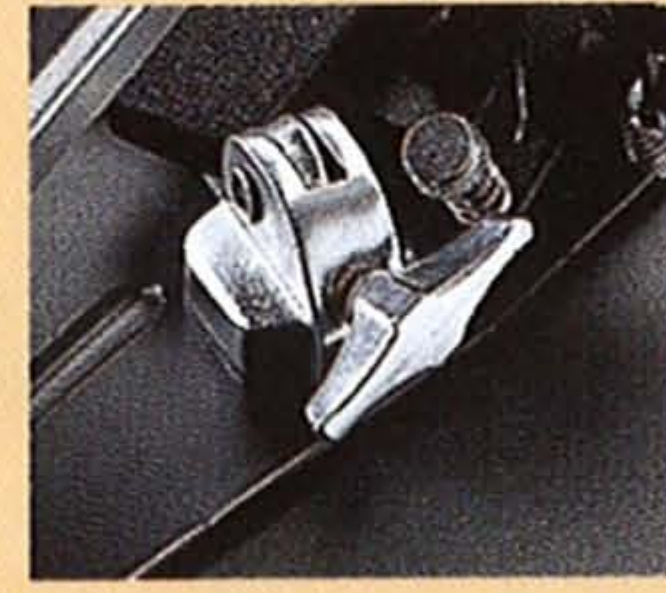

Hoop Clamp System

Pearl's side accessible hoop clamp system makes pedal attachment and removal fast and simple. With no interference from clamp bolts, low footboard angles can be achieved without "bottoming-out." (US.PAT. 5726370)



Stainless Steel Universal Joint

All Pearl Eliminator double pedals now are standard with Stainless Steel Universal Joints featuring ultra-precise tolerances for accurate and lag-free play. The durability of stainless steel is legendary but we've gone further and made the walls 20% thicker to boot for bullet proof dependability you can rely on gig, after gig, after gig.... (Twin pedal Only)

PowerShifter

P-201P

- PowerShifter Function
- Quad Beater
- Double Chain Drive
- Floating Spring Pendulum
- Infinite Beater Angle
- Adjustable Height Footboard
- Roller Cam Hoop Clamp System
- PowerPlate



PowerShifter

P-101P

- PowerShifter Function
- Quad Beater
- Single Chain Drive
- Floating Spring Pendulum
- Infinite Beater Angle
- Roller Cam Hoop Clamp System
- PowerPlate



PowerPro NEW

P-100P

- Quad Beater
- Beater Angle Adjustment
- Single Chain Drive
- Spring Tension Adjustment
- Silent, Smooth Chain Channel
- Power Plate



PowerPro NEW

P-100

- "DuoBeat" Two Way Beater
- Beater Angle Adjustment
- Single Chain Drive
- Spring Tension Adjustment
- Silent, Smooth Chain Channel



PowerPro

Infinitely Adjustable Beater Angle

Our popular PowerPro P-100, P-100P and P-100TW pedals now feature an infinitely adjustable beater angle for improved feel and comfort.

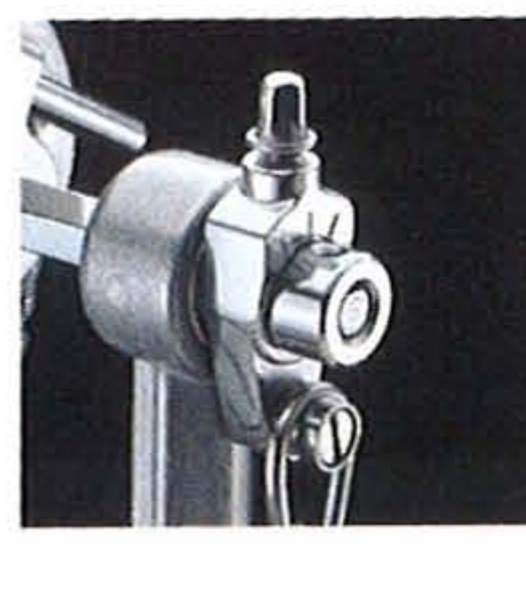

PowerShifter

P-202TW

- PowerShifter Function
- 2 Quad Beaters
- Double Chain Drive on both pedals
- Floating Spring Pendulum
- Infinite Beater Angle
- 2 Adjustable Height Footboards
- Roller Cam Hoop Clamp
- PowerPlate
- Aircraft Quality Aluminum Drive Shaft
- Stainless Steel Universal Joints

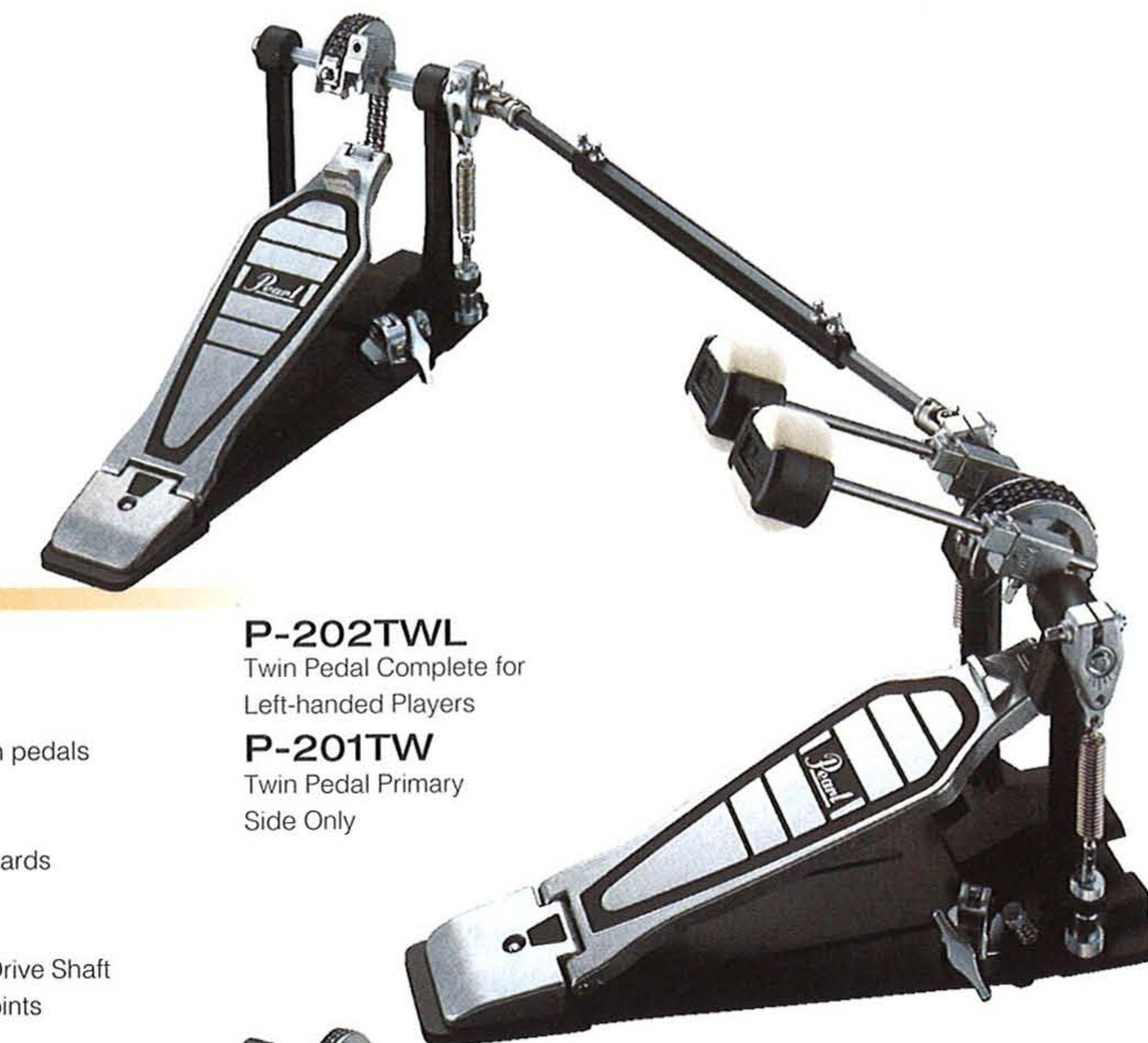

P-202TWL

Twin Pedal Complete for Left-handed Players

P-201TW

Twin Pedal Primary Side Only

PowerShifter

P-102TW

- PowerShifter Function
- 2 Quad Beaters
- Single Chain Drive on both pedals
- Floating Spring Pendulum
- Infinite Beater Angle
- Roller Cam Hoop Clamp
- Silent, Smooth Chain Channel
- PowerPlate
- Aircraft Quality Aluminum Drive Shaft
- Stainless Steel Universal Joints



P-102TWL

Twin Pedal Complete for Left-handed Players

P-101TW

Twin Pedal Primary Side Only

PowerPro

P-100TW

- "DuoBeat" Two Way Beaters
- Single Chain Drive on both pedals
- Spring Tension Adjustment
- Roller Cam Hoop Clamp (main pedal only)
- Silent, Smooth Chain Channel
- PowerPlate
- Aircraft Quality Aluminum Drive Shaft
- Stainless Steel Universal Joints



Pedal Stabilizer

The PS-85 attaches to the secondary pedal of most double pedals and adds slip prevention and stability.

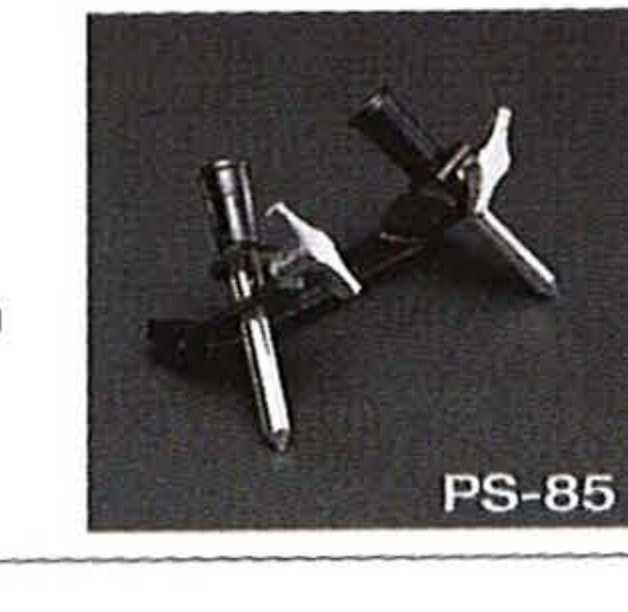

PS-85

Hi-Hat Stand & Remort Hi-Hat

PowerShifter Eliminator

Pearl's Eliminator Hi-Hat represents the smoothest, most natural feeling Hi-Hat drive system ever designed. This revolutionary Hi-Hat is a complete departure from normal Hi-Hats, offering feature after feature to set new standards for function, adjustability, and above all, playing comfort. The totally natural feel of our Eliminator Hi-Hat is centered around its PosiLink Twin Cam Drive System. PosiLink's interchangeable Drive Cam and interactive double chain design, together with other outstanding features like our SuperGrip Clutch, VariSet Footboard Angle Adjustment System, exciting PowerShifter function, and reversible TractionPlate footboard, add up to a Hi-Hat that performs as if it were an extension of your thoughts. The RH-2000 combines the H-2000 Eliminator Hi-Hat's Posi-Link Twin Cam drive system with a third-generation low-friction cable to produce the smoothest, lightning-fast, natural feeling remote hat in the world.

NEW RH-2000

- Features:
- Newly designed Smooth Cable System
 - 8 Foot Cable
 - Eliminator Interchangeable Cams
 - VariSet Footboard Angle Adjustment
 - Traction Plate Footboard
 - PowerShifter
 - SuperGrip Clutch
 - Precision Spring Tension Dial
 - Swiveling Dual Legs
 - Convertible Rubber/Spiked Tipped Feet



H-2000

Hi-Hat Stands



H-985W

- Rubber Cymbal Seat
- Rubber Clutch Washers
- Easy Reach Tension Adjustment Knob
- Vari-link footboard height adjustment System
- Omni-Pod Swiveling Legs
- Reversible Spike/Rubber Tipped Feet
- Double Braced Legs

H-885

- Roller Pulley System
- Omni-Pod Swiveling Legs
- Adjustable Height Footboard
- Reversible Spike/Rubber Tipped Feet
- Adjustable Spring Tension

H-855

- Omni-Pod Swiveling Legs
- Reversible Spike/Rubber Tipped Feet
- Adjustable Spring Tension

H-800W

- Omni-Pod Swiveling Double Braced Legs
- Adjustable Spring Tension

H-70W

- Double Braced Legs

All Pearl hi-hats feature internal pull springs for superior performance and speed. Unlike compression springs that rub causing friction and slowness, Pearl's pull springs are virtually friction free for silent operation, silky smoothness, and incredible speed. The H-985W Vari-Link Hi-Hat provides infinite footboard height adjustments for comfort and speed. The spring tension screw is conveniently positioned within easy reach for tension adjustments while playing. The clutch spacers and seat cup are specially formed from non-sound absorbing rubber to maximize cymbal clarity and projection. The H-885 features our unique Roller Pulley System which requires half the effort of direct drive hi-hats, providing a lighter feel when using heavier cymbals, and also features full footboard angle adjustability. Both of the H-885 and H-855 features swiveling legs and reversible Spike/Rubber tips. The H-800W PowerPro Hi-Hat features double braced swiveling legs, adjustable spring tension, our CL-68 clutch, and is built to Pearl's legendary quality standards, offering a great value.

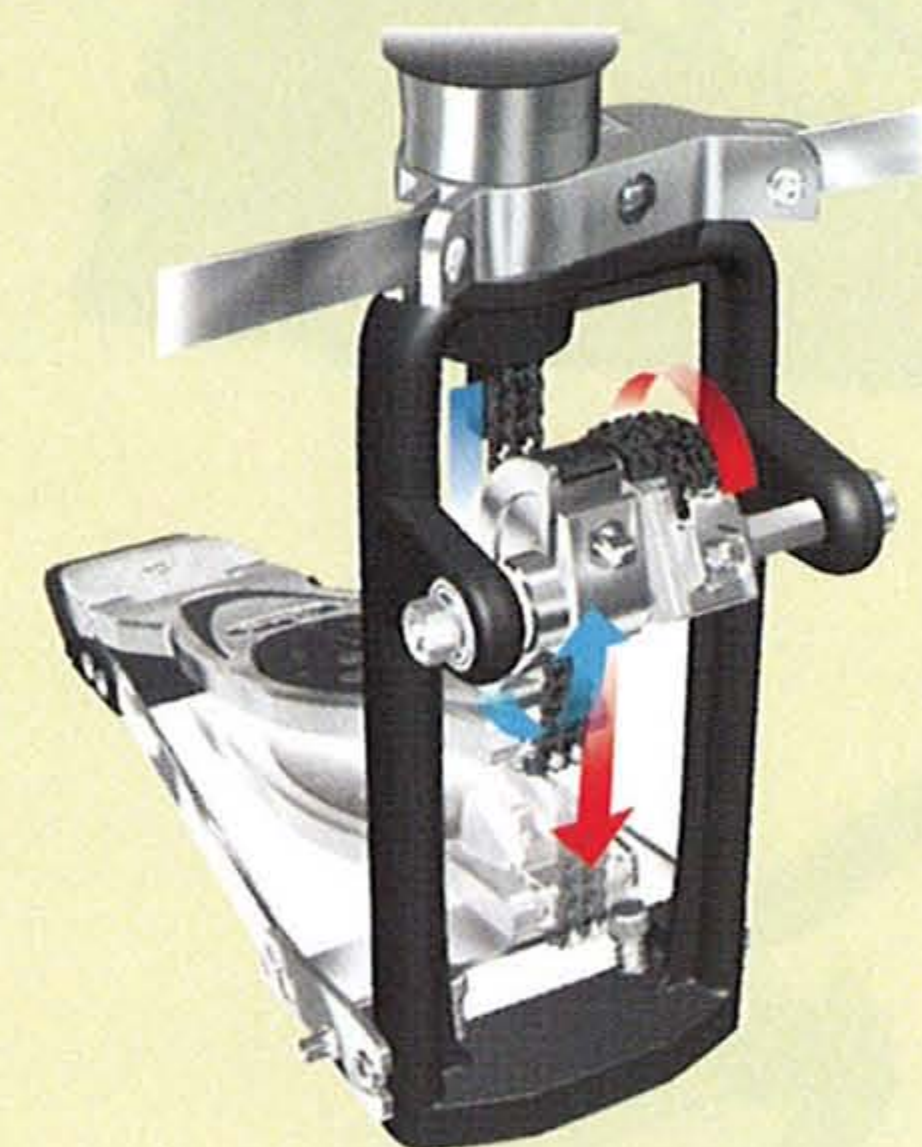

PosiLink Twin Cam Drive System

This exclusive Hi-Hat drive system utilizes two cams and two double link chains, working together, to provide the smoothest, quietest, most natural feeling Hi-Hat action ever imaginable. No other system can provide the extreme torque, natural response and tight, crisp Hi-Hat sound offered by this exciting innovation in Hi-Hat drive design. We've even replaced the normal felt washer on the lower pull rod return with a spring to quiet the pedal when removing your foot, and to greatly improve the pedal response while playing.



Interchangeable Cam

You can easily custom tailor the response curve and action of the Eliminator Hi-Hat by choosing between four different cam options. Our Black Cam provides a smooth, constant, very natural linear action. Our White Cam is also Linear but with a slightly lighter feel. The Blue Cam accelerates with speed and power as it's played and our Red Cam is the most radical and aggressive. This system allows you to play as normal or as aggressive as you like and can be used to offset the feel of heavier cymbals. Each Eliminator Hi-Hat includes all four cams. (US.PAT. 6399866)



VariSet Footboard Angle Adjustment

Unlike "gear" type adjustment systems common with other Pedals and Hi-Hats, our VariSet system allows you to effortlessly rotate the pull cam to change the angle of the footboard offering a much wider range of angle adjustability. The pedal height can also be adjusted on the pedal cam side, allowing you to also quickly compensate for the difference in footboard heights produced by interchanging the cams.

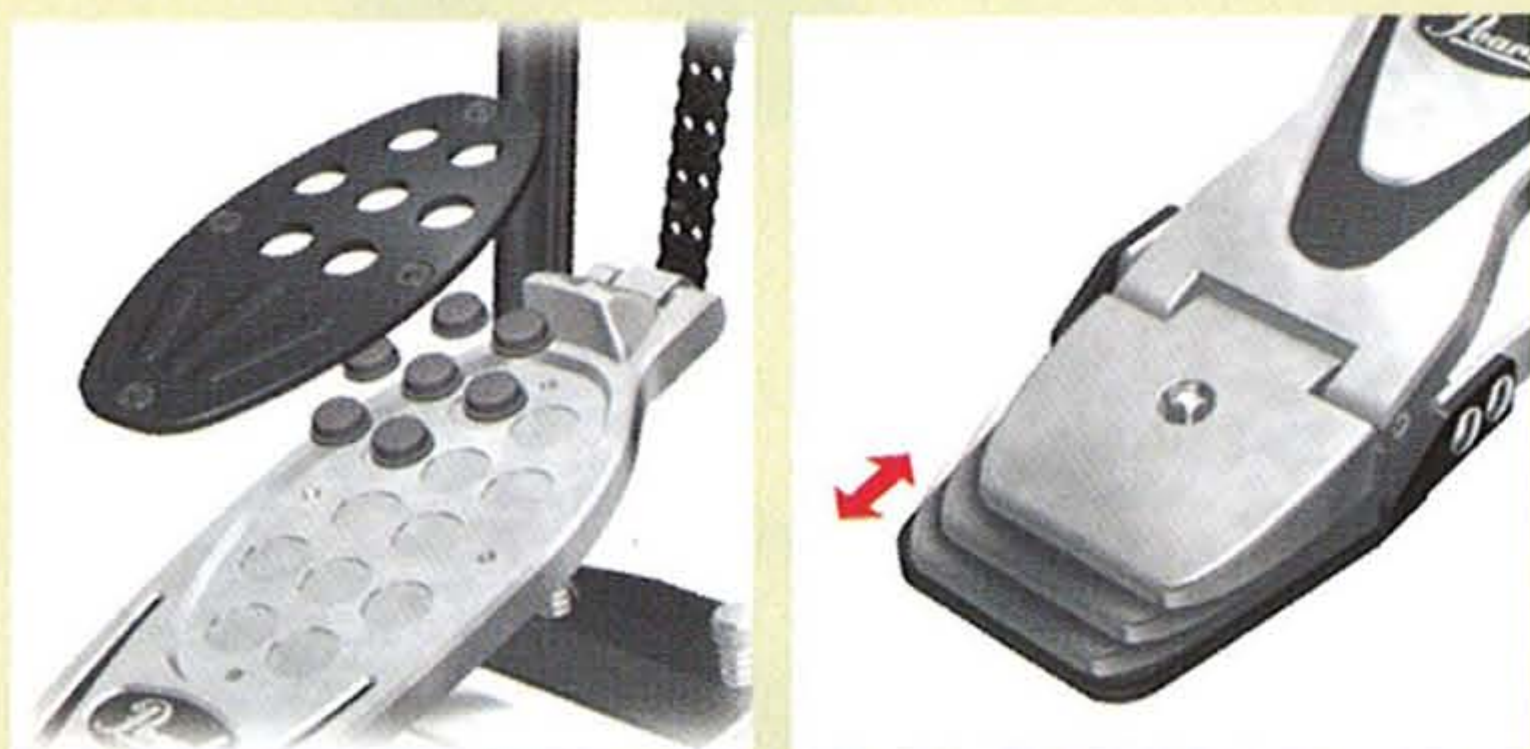

TractionPlate Footboard

This concept in footboard design is shared with our Eliminator Bass Drum Pedal and allows you to remove and reconfigure each individual traction grip to suit your exact requirements. The TractionPlate is also reversible allowing you to position the slide or grip of the plate at either the front or rear of the pedal.

PowerShifter

This revolutionary function, first introduced on our now famous PowerShifter Bass Drum Pedal, allows you to move the footboard to one of three preset positions. This changes the angle of the pull chain and thus allows you to adjust the feel and action of the Hi-Hat from a light feel, to one with extreme power and torque.



SuperGrip Clutch

Our SuperGrip Clutch design is the strongest, most dependable system available today. It features a completely solid upper and lower tunnel design with a center gripping hinge to hold your upper Hi-Hat Cymbal securely like no other clutch has ever done before. It also features a die-cast wingnut designed to allow you to easily and securely tighten the cymbal.



Precision Spring Tension Dial

Eliminator's Precision Spring Tension Dial is engineered with a multitude of exact steps allowing you to precisely and quickly dial in your optimum tension setting. This innovative system offers a far greater tension range and its exact locked-in steps will not slip or move under stress.



Reversible Rubber/Spiked Tipped Feet

Our convertible rubber feet feature an attached steel spike that can quickly be rotated into place providing the ultimate in traction when needed.

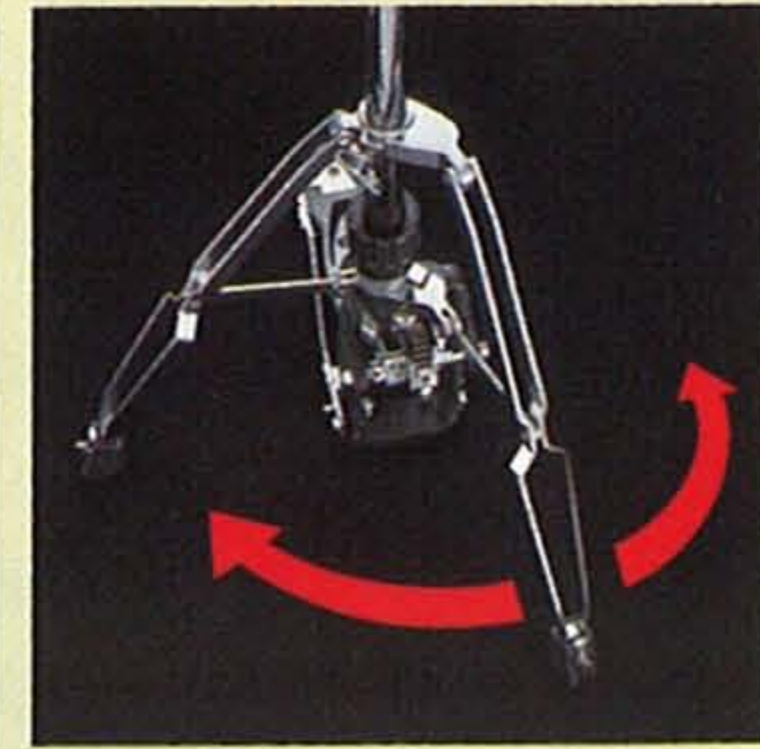

Swiveling Dual-Legs

Eliminator's Swiveling Dual-Legs allow perfect positioning with Twin Bass Drum Pedals and other accessory pedals while still maintaining a firm, stable stance. Its offset post design also provides closer positioning with your snare drum while leaving the pedal in the normal playing position.



CL-98P

Hi-Hat Clutch

The CL-98P hi-hat clutch grips the pull rod at three points for dependable, slip-proof performance. Minimal contact rubber washers allow the cymbals to ring freely creating an open, lively sound, with clarity that must be heard to be believed.



Spike/Rubber Tips

The H-985W features reversible spike/rubber tip feet for slip-resistance on all types of flooring surfaces. The foot also rotates to allow precise adjustments for best stability.



Spring Tension Adjustment

The H-985W's spring tension adjustment system is ergonomically located for easy reach allowing adjustments while playing.



Spike/Rubber Tips

The H-885 and H-855 Hi-Hats feature fixed position reversible spike/rubber tips for extra stability.



Cymbal Seat

Our rubber cymbal seat contacts the cymbal at only three points for a noticeable improvement in both resonance and clarity. Each contact is contoured to help keep the cymbal centered for a consistent sound. Standard on the H-985W.



Swiveling Legs

Pearl hi-hats feature full swiveling legs making them perfect for use with double pedals and various other accessory foot pedal set-ups. Swiveling legs are standard on H-985W, H-885, H-855 and H-800W models.

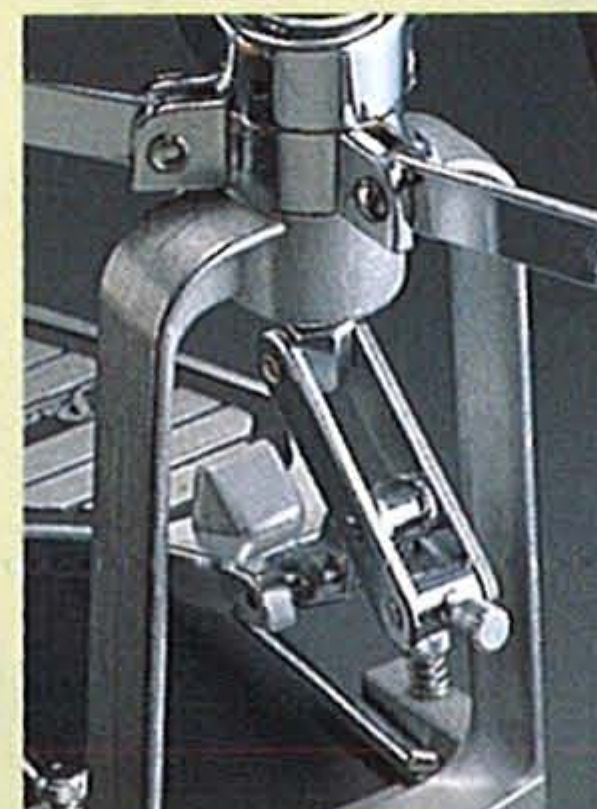

Vari-Link System

The Vari-Link System features an adjustable linkage for infinite footboard angle settings. The footboard angle can be set for optimum playing comfort and to match the height of double pedals providing quick transitions.

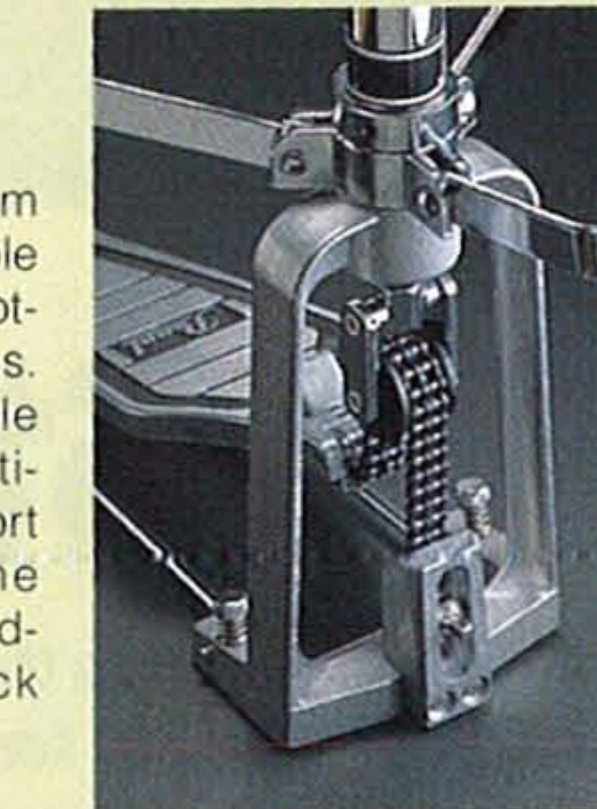

Roller Pulley System

The H-885's Roller Pulley System is the smoothest Hi-Hat system available. Its dual rotating wheels swivel as they move to offer an amazingly light and swift action. The footboard angle is also completely adjustable for comfort. (US.PAT 5018426)

Closed Hat

The CLH-100 features a boom arm with stop-lock and Pearl's infinitely adjustable Uni-Lock tilter for ultra-precise positioning, versatility, and ease-of-use.



CLH-100

Drop Clutch

The DCL-90 Drop Clutch closes the hi-hats without foot pressure. This allows playing "two-footed" patterns and closed hats at the same time. Normal hi-hat play is resumed by simply stepping on the footboard.



DCL-90

Hi-Hat Attachment

The HA-100 Hi-hat to Bass Drum Attachment features our newly designed hoop clamp with floating grippers that follow the contour of the hoops for excellent clamping power and hoopprotection. The seven-way adjustment system allows virtually any angle for precise hi-hat positioning.

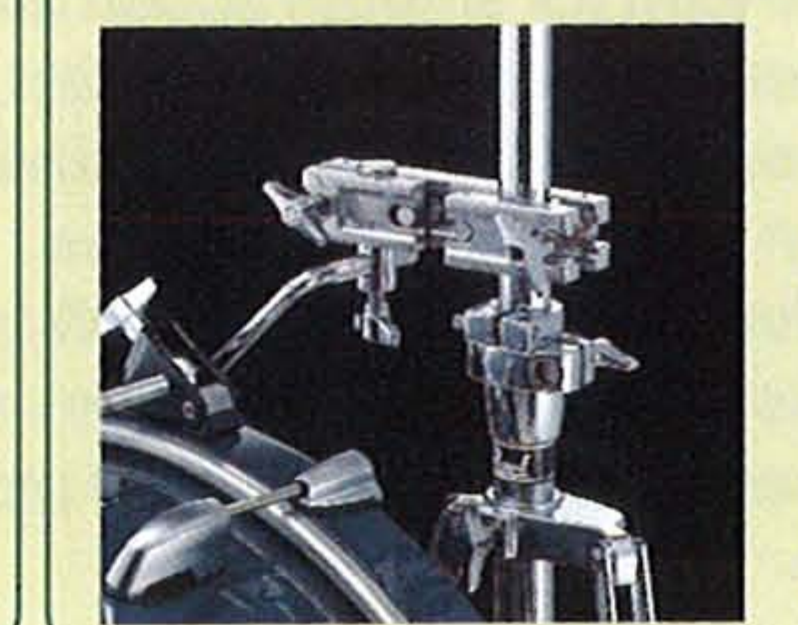

NEW HA-100

Drum Thrones

Pearl's top of the line Roadster thrones are made with the touring musician in mind. Their solid steel "PanHead" seat base promotes a lower center of gravity which in turn provides a more stable, totally secure, drumming foundation. All Pearl thrones also feature a highly durable, die-cast seat clamping system for extra durability, and Roadster Thrones provide a super strong, one step locking collar to securely lock-in your height adjustment. Our Roadster D-220, D-150 and D-150S thrones feature a super comfortable AirFlo fabric covered cushion that allows the seat to breathe, providing optimum comfort during those extended gigs. Our D-220C and D-150C feature a plush seat top for the most luxurious comfort imaginable. Our Roadster D-150S provides a shorter height stance for players that like to sit low. Our standard series D-80 throne provides a sturdy double leg tripod, easy height adjustment and a smaller style bike seat designed of both speed and comfort. Our D-75 provides a round vinyl covered seat with all the same outstanding features as the D-80. Our D70W features double braced legs for maximum stability, and a vinyl covered round seat designed for comfort.



Roadster D-220C
(Plush)
Height Adjusts from 440-600mm (17.32"-23.62")

Roadster D-220
(AirFlo fabric)
Height Adjusts from 440-600mm (17.32"-23.62")

Roadster D-150
(AirFlo fabric)
Height Adjusts from 450-610mm (17.71"-24.01")

Roadster D-150S
(AirFlo fabric)
Height Adjusts from 405-560mm (15.94"-22.04")

Roadster D-150C
(Plush)
Height Adjusts from 450-610mm (17.71"-24.01")

D-80
Height Adjusts from 430-680mm (16.92"-26.77")

D-75
Height Adjusts from 430-680mm (16.92"-26.77")

D-70W
Height Adjusts from 430-650mm (16.92"-26.77")

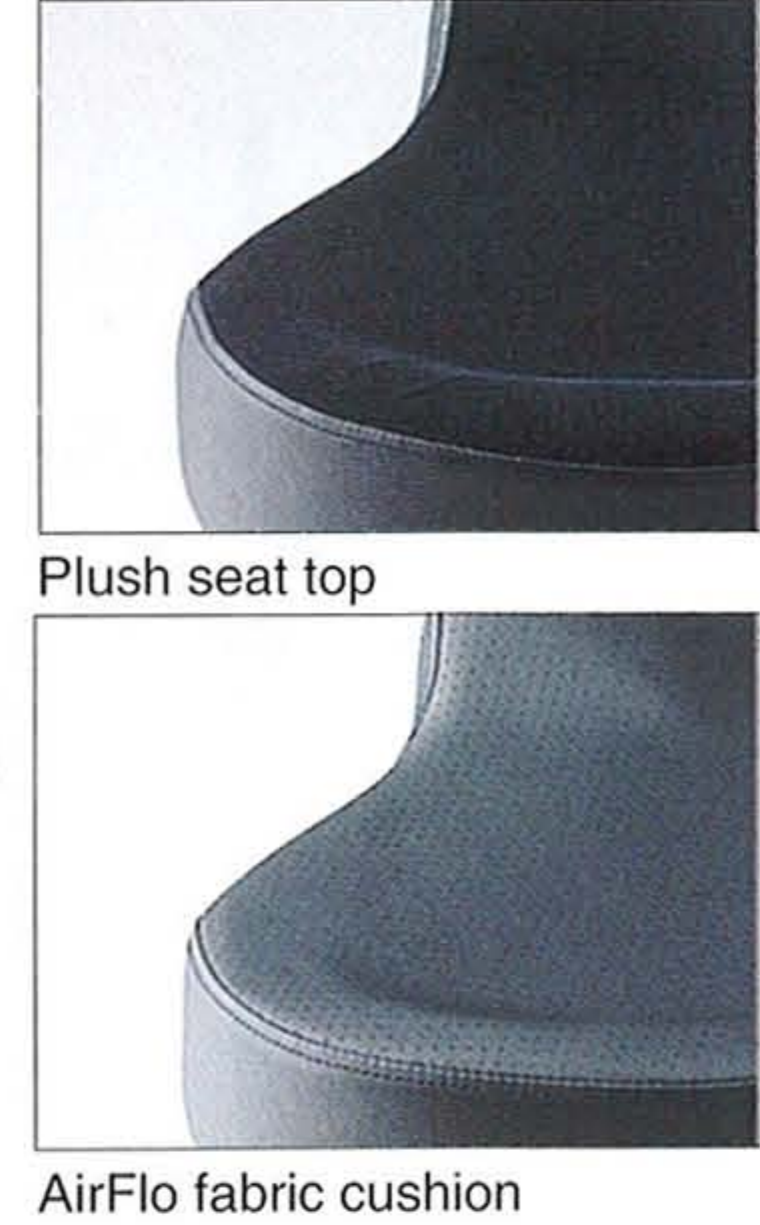

Plush seat top

AirFlo fabric cushion



Seat Clamping System

Our Roadster thrones feature a die-cast seat clamping system which offers strength, perfect stability, and security.

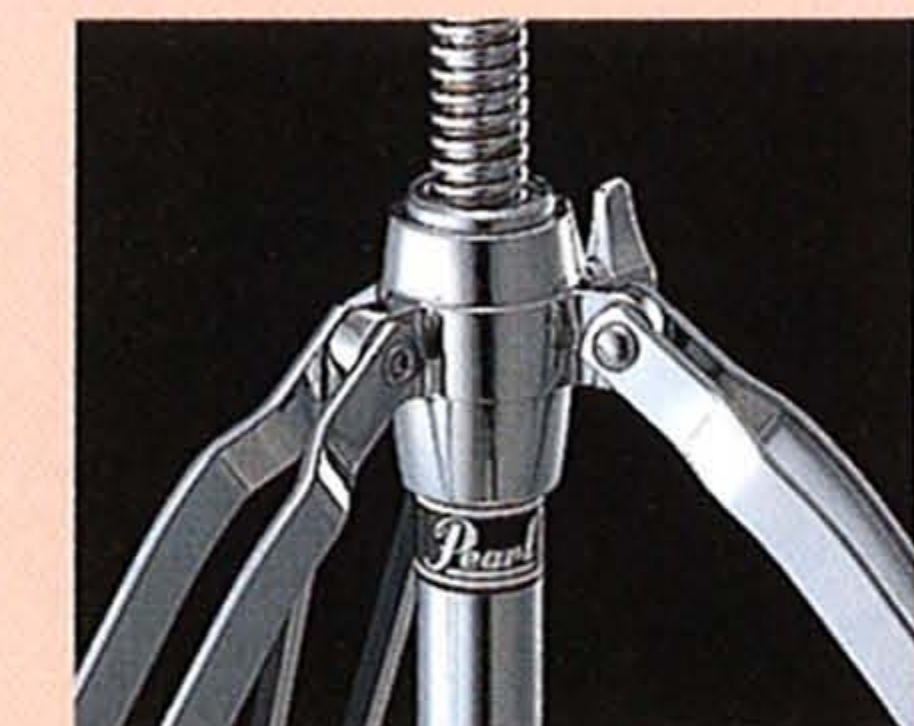

Spiral Joint

Our D-220 and D-150 Roadster Thrones feature a spiral height adjustment post with super strong one-step locking collar for simple "spin and lock" height adjustment settings.

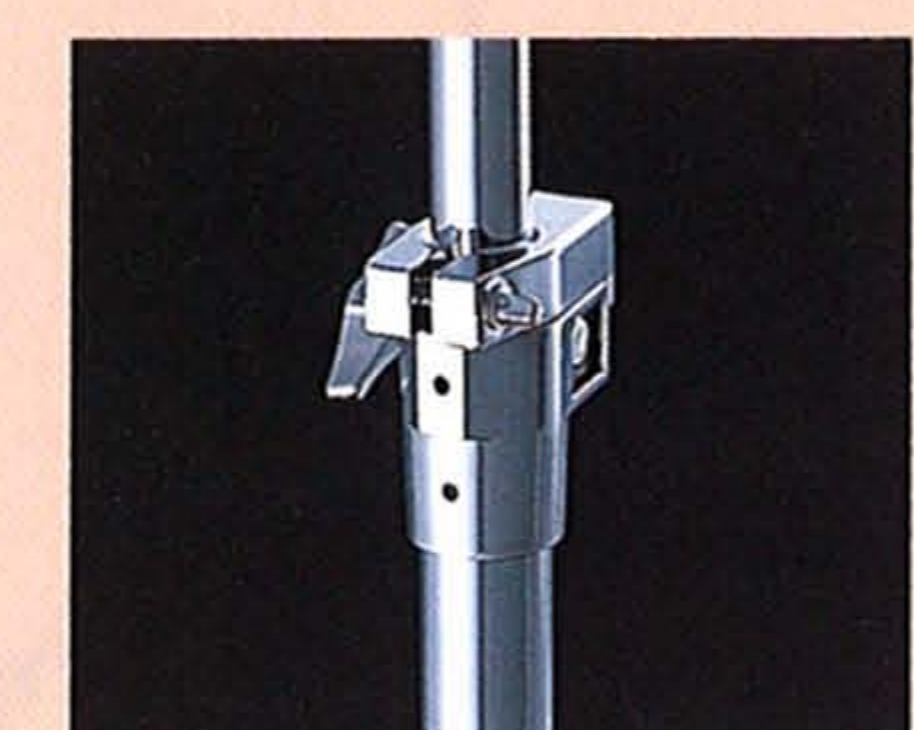

Standard Height Adjustment Joint

Our D-80, D-75 and D-70W model Thrones feature a compression collar with nylon bushings for secure height adjustments. A stop-lock is provided for added slip resistance.

Drum Racks

ICON Rack

Our patented non-slip square tube rack design has always separated Pearl from the pipe puzzle type designs offered by others. Our ICON Rack System provides independent control over the height of each tube and its square aluminum tube design insures your mounts will not spin or loosen after they're positioned. Our new DR-503 (three section), DR-501 (bridge rack), and DR-501E (extension) incorporate all the features that made the ICON rack famous but with new longer stabilizer feet that allows the front section of the DR-503 to be used as a bridge rack if desired. In addition, the DR-503 and DR-501 now include a pair of brackets that attach to the leg posts for versatile attachment of tom and/or cymbal holders. The brackets are available separately for retrofitting older ICON racks.



NEW DR-503

The DR-503 features three independently height adjustable sections: a front and two sides. Quick release couplers and memory clamps insure a quick, accurate set-up, time after time. Extra long stabilizer feet provide superb stability and allow the front section of the DR-503 to be used as a bridge rack if desired. The DR-503 comes standard equipped with four PC-50 pipe clamps and, in addition, a pair of PCL-100 brackets are included for attachment of tom/cymbal holders to the tops of the leg posts. Additional DR-501E extenders can be purchased, one leg and one side, for double bass and custom set-ups.

DR-80

The DR-80 is a lighter weight three section rack with fixed-height legs that folds for easy transport. Includes four PC-8 pipe clamps.

NEW DR-501

NEW DR-501E

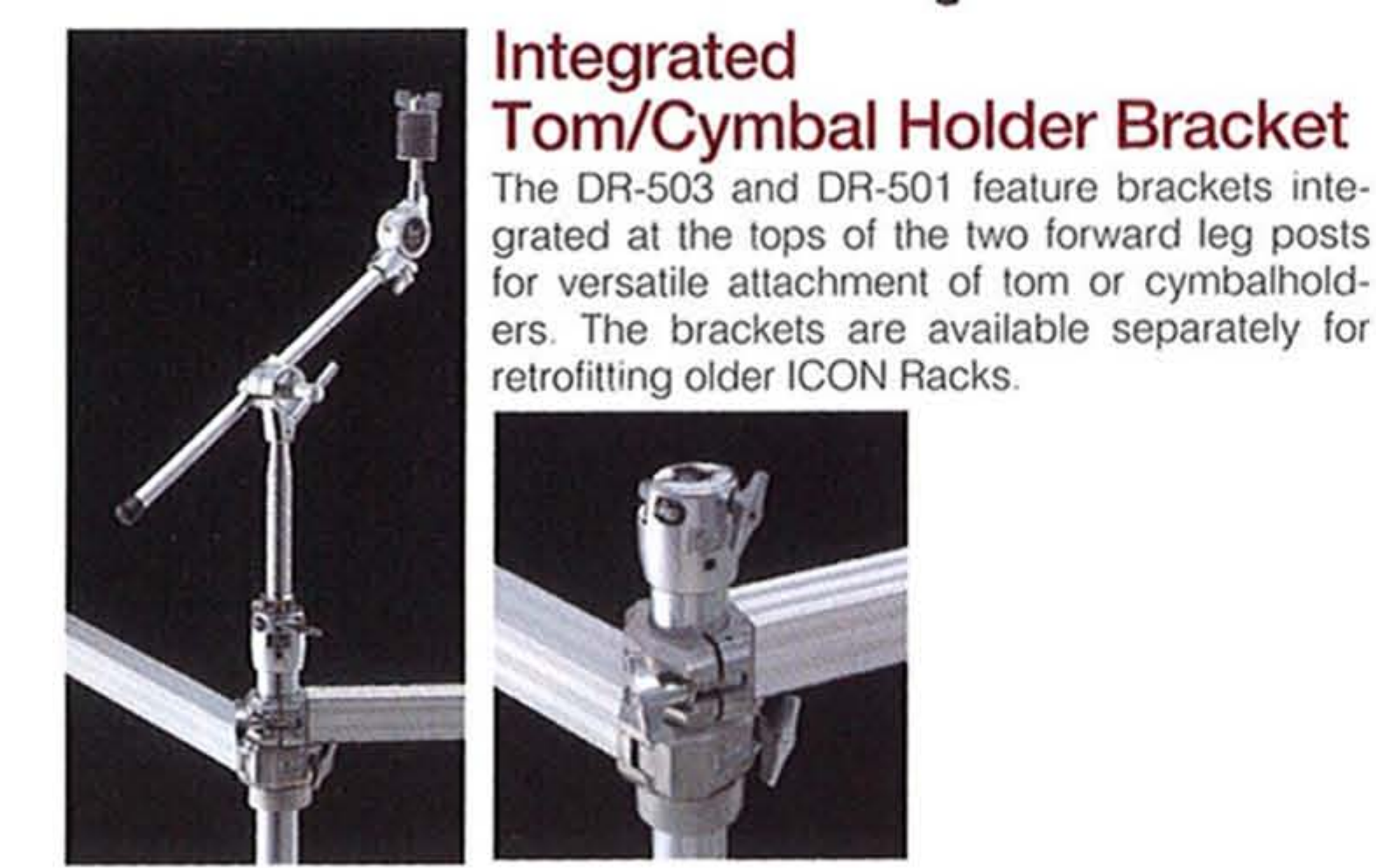

Integrated Tom/Cymbal Holder Bracket

The DR-503 and DR-501 feature brackets integrated at the tops of the two forward leg posts for versatile attachment of tom or cymbalholders. The brackets are available separately for retrofitting older ICON Racks.

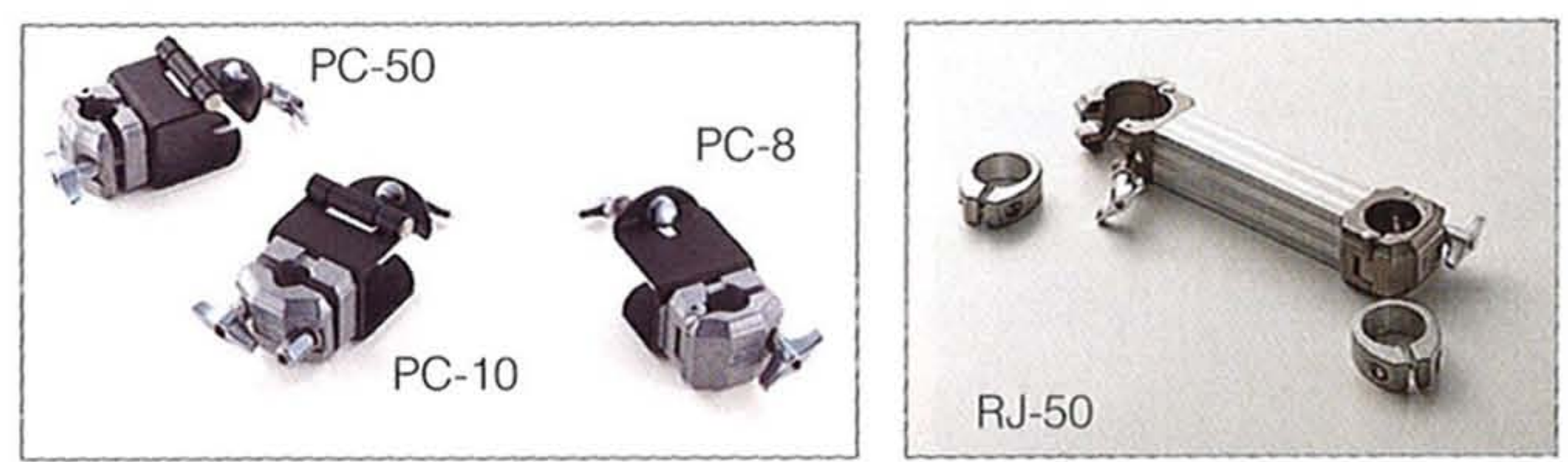

Pipe Clamps

PC-50 and PC-8 pipe clamps feature hinged quick release jaws for quick set-ups. Both accommodate 7/8" posts and SX-2 Stop-Locks. The reissued PC-10 features heavy-duty adjustable jaws capable of accommodating a wide range of tubing sizes.

Rack Joint

The RJ-50 is ideal for jointing two DR-503 ICON racks together for double bass or extended set-up applications.

Snare Stands

Our new S-2000 Snare Stand features three adjustable arms to accommodate drums from 10" to 16" for outstanding versatility. Each arm features a thermometer-like index system for quick and accurate size settings. Air Suspension rubber tips allow drums to resonate freely while hooks hold the drums securely even when tilted at extreme angles. The S-2000 features dual pivoting Uni-Lock tilter for simultaneous fore/aft and left/right positioning with state-of-the-art precision. Other features include nylon sleeved pipe joint for smooth action and sturdy double braced legs with reversible rubber/spike feet. Our S-985W offers all the outstanding features of the S-2000 without the adjustable arm and Air Suspension tips. Our S-885W features all the features of the S-985W but without the reversible rubber/spike feet. The S-850 features a Uni-Lock basket tilter, oversized snare grips, nylon sleeved pipe joint and sturdy single braced legs.

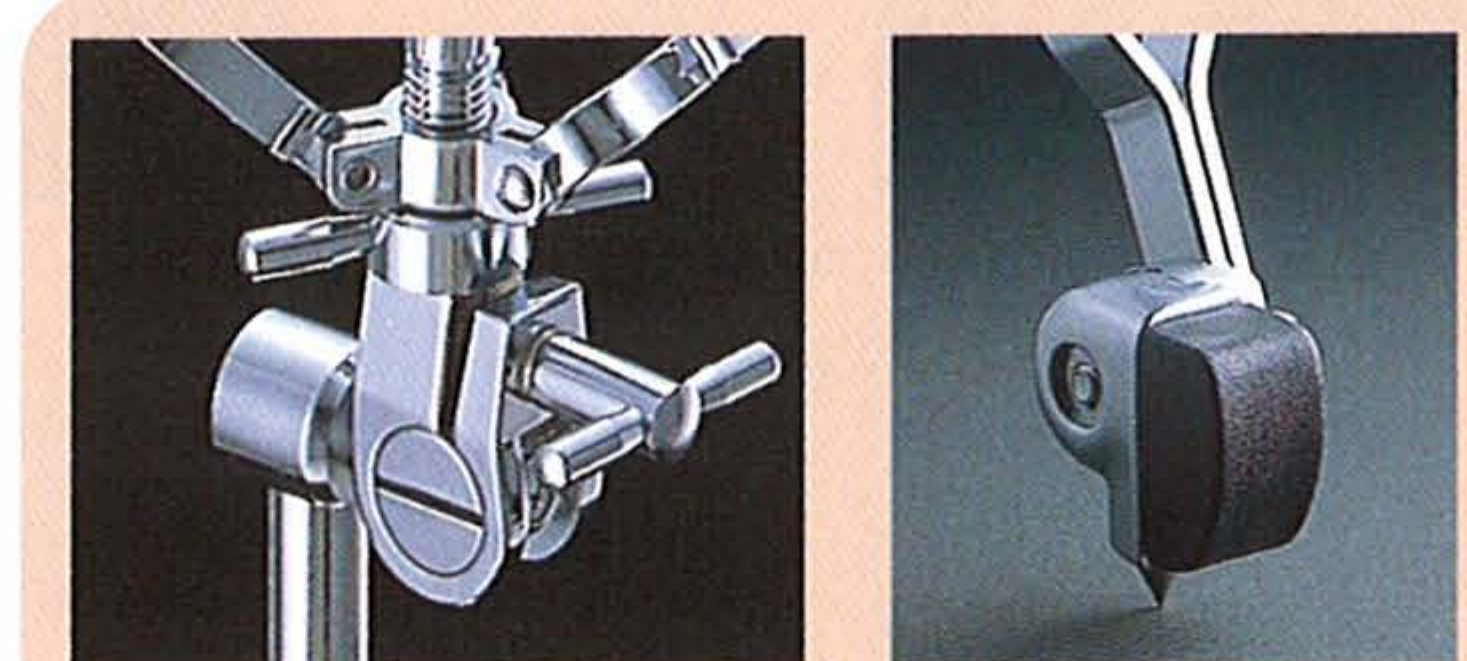

Dual Uni-Lock Basket Angle Adjustment System

The Uni-Lock System provides infinite angling for precise snare drum positioning. Our S-2000, S-985W, and S-885W feature dual-action Uni-Lock tilters for simultaneous fore/aft and left/right positioning for perfect drum placement every time.

Spike / Rubber Tips

The S-2000 and S-985W feature spike tips for additional slip-resistance when needed. Its reversible feet also pivot permitting the tips to remain perpendicular to the floor regardless of tripod spread.

NEW S-2000

- Fits drums from 10" to 16" in diameter
- Dual-Tilt Uni-Lock Tilter
- Air Suspension Rubber Tips
- Double Braced Legs
- Reversible Spike-Rubber Tips

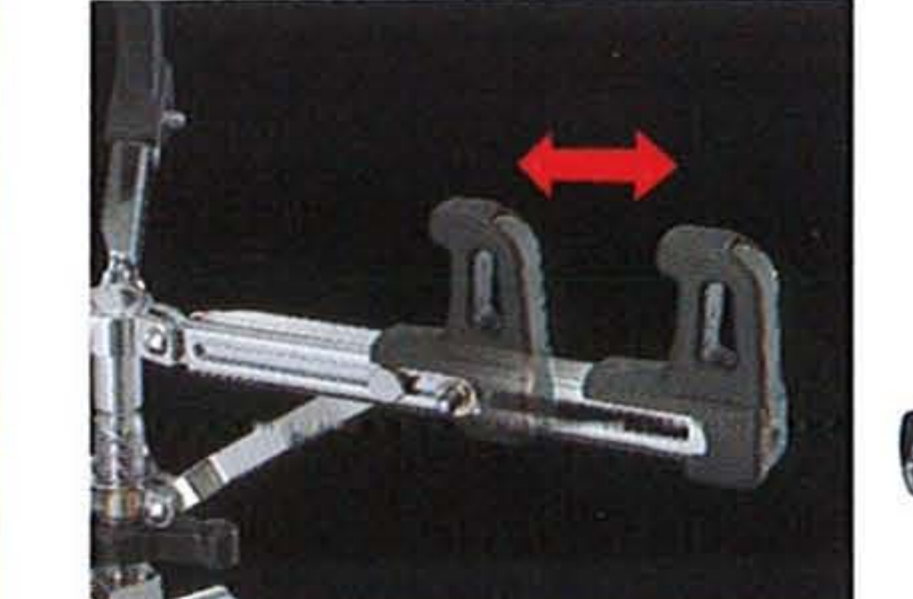

Three Adjustable Arms to accommodate drums from 10" to 16" for outstanding versatility. (PAT. PEND. /USA)



S-985W
• Dual Uni-Lock Basket Angle Adjustment system
• Double Braced Legs
• Reversible Rubber/Spike Feet

S-885W
• Dual Uni-Lock Basket Angle Adjustment system
• Double Braced Legs

S-850
• Uni-Lock Basket Tilter
• Single Braced Legs

S-800W
• Gear System Basket Tilter
• Double Braced Legs

S-70W
• Gear System Basket Tilter
• Double Braced Legs

Cymbal Stands & Boom Stands

Pearl cymbal and boom stands offer the unmatched quality and features that have made them the absolute finest available today. All 855 series stands feature our patented Uni-Lock infinitely adjustable tilters for precise cymbal positioning. 855 and 800 series boom stands are equipped with boom arm Stop-Locks for slip prevention and quick set-ups. For value, nothing beats our PowerPro series Cymbal and Boom stands. The PowerPro B-800W and C-800W offer double braced legs, three sections, slim-line pipe joints, and superior Pearl quality at unbeatable pricing.



Boom/Straight Cymbal Stand

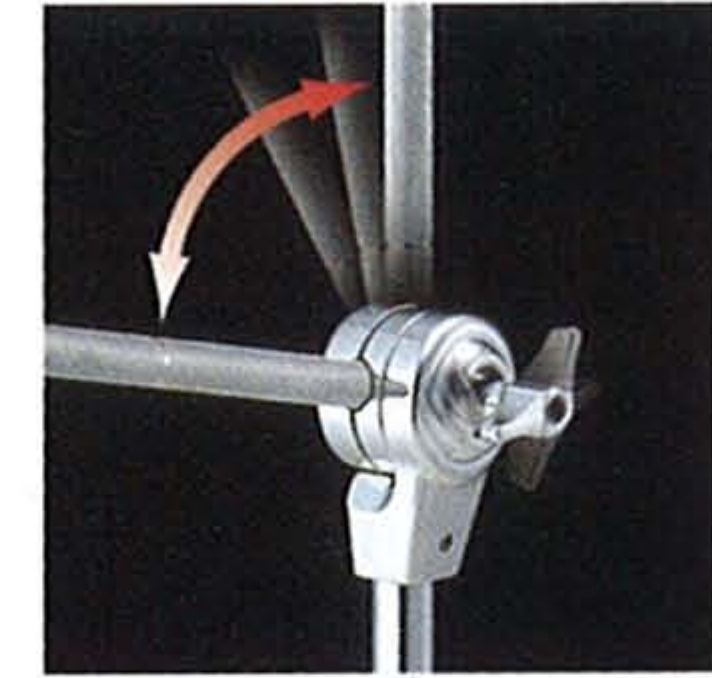

Pearl's BC-800W can be used as either a traditional straight cymbal stand, or as a boom stand, to double your options in positioning cymbals. The top section can be used in a vertical position as a normal straight cymbal stand or be adjusted into an angled position to turn it into a full featured boom stand.

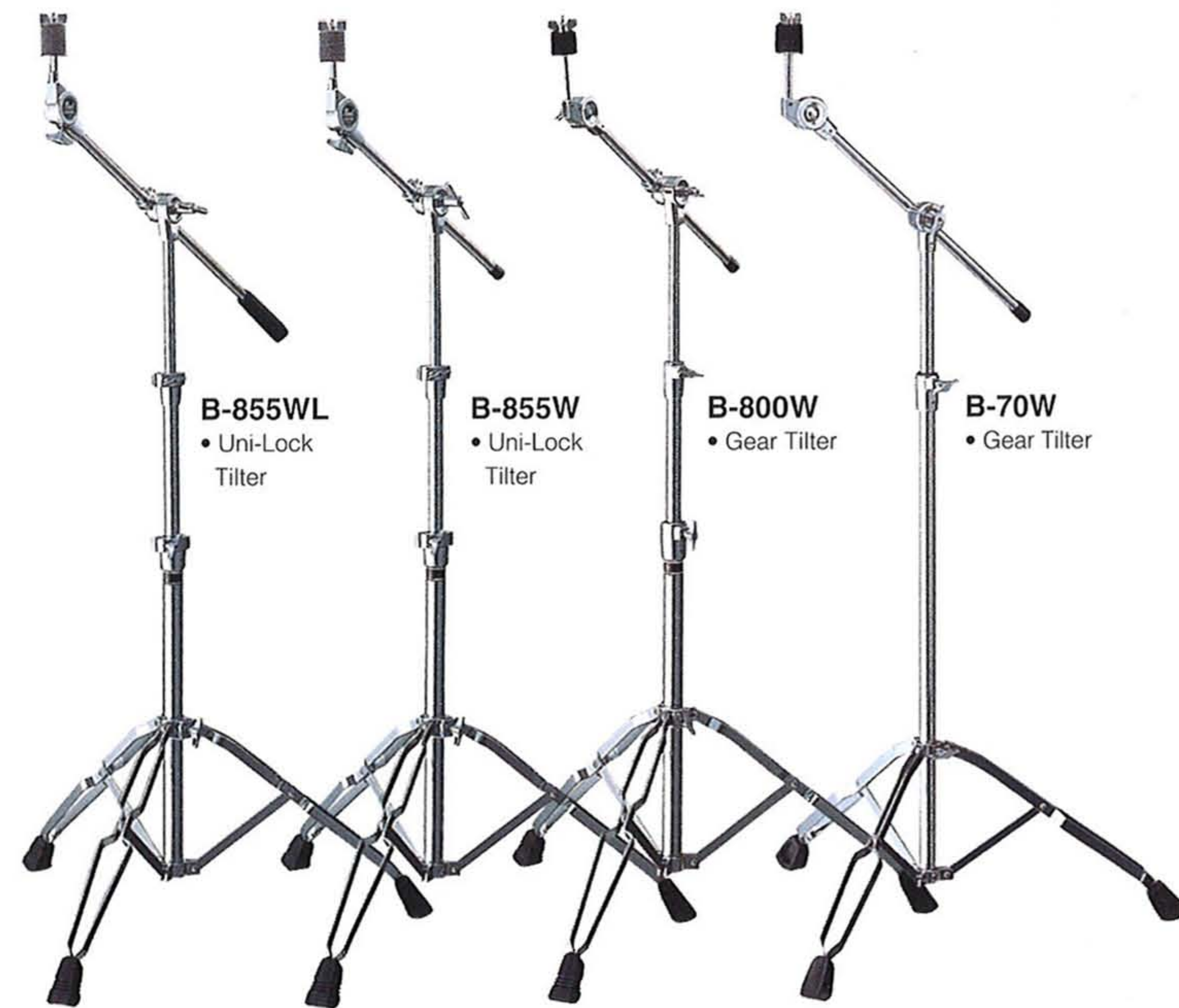

Uni-Lock Tilter

Our Uni-Lock Tilter features an internal "brake drum" type locking system for infinite angling possibilities and slip-proof dependability.



Boom Arm Stopper

All 855 series and 800 series boom stands feature Stop-Lock equipped boom arms for quick, repeatable set-ups and 100% slip-prevention.



Nylon Bushing Joint

All 855 series stands feature non-marring nylon bushings and our professional 360 degree full-surface gripping collars for positive slip-proof height settings.



SlimLine Joint

PowerPro series stands feature our SlimLine pipe joints with extra long nylon sleeves for perfect vertical alignment of all tubes.

Cymbal Holders

Pearl's cymbal holders offer the easiest way to add cymbals to your rack set-up or standard set-up with stands. Our CH-88L offers a super long reach and features our infinitely adjustable Uni-Lock internal braking system tilter for pinpoint cymbal positioning. The CH-88L's oversized counterweight provides extra stability for heavier cymbals or when extended to maximum length. Our CH-88 shares all the features of the CH-88L but with a standard length boom and no counter weight. Our CH-80 is similar to the CH-88 but with a deep gear tilter instead of Uni-Lock. Our CH-70 is perfect for adding splash and crash cymbals to any set and comes complete with an adapter clamp.

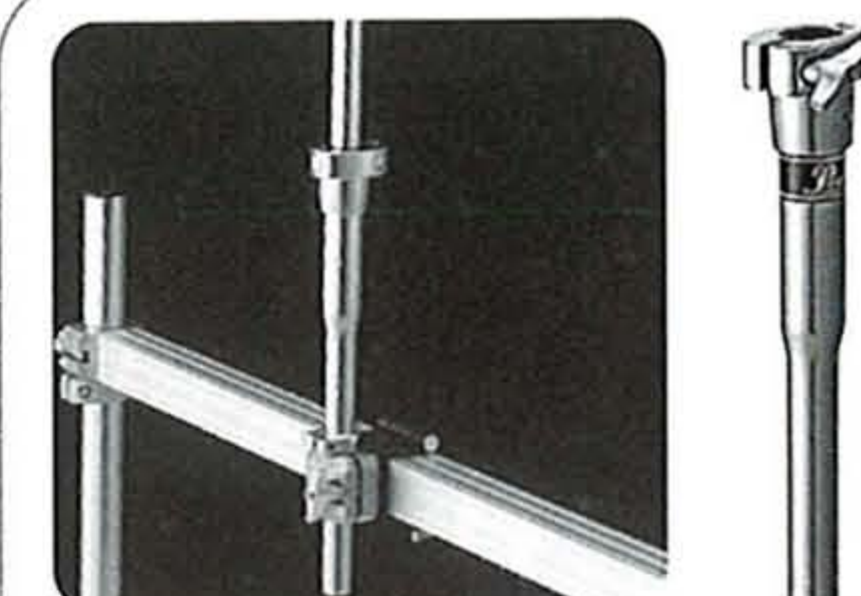
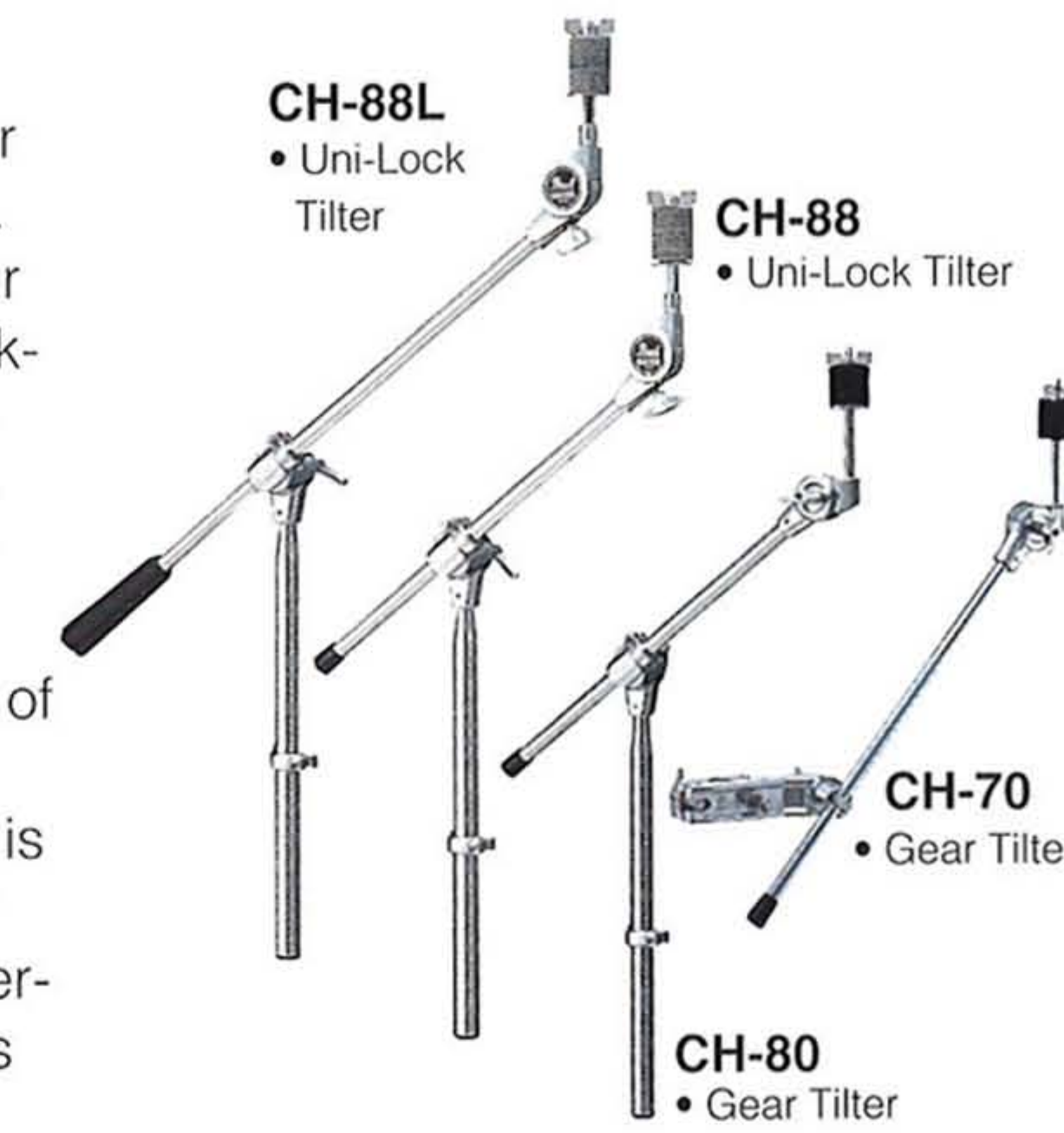

Tube Extender

TX-80
Our TX-80 Tube Extender allows you to increase the reach or height of any cymbal arm, tom arm or stand that uses a standard 7/8" diameter pipe. For a stand, simply remove your existing pipe, slide in the TX-80 and slide your existing pipe into the TX-80.

Cymbal Stacker

The CST-80 Cymbal Stacker features our exclusive Dual Action Tilters that allow inline and offset mounting for virtually unlimited positioning and angling possibilities. The CST-80 features non-slip gear tilters and is compatible with C-800W, B-800W, BC-800W, C-70W, and B-70W stands and the CH-70 Cymbal Holder.



Cowbell Holders

Our new CA-100 hoop mounted cowbell holder features floating grippers that follow the contour of the hoops for excellent clamping power and hoop protection. The included universal-fit 3/8" knurled L-arm telescopes and tilts for perfect placement of cowbells or effects. The 75H hoop mounted cowbell holder features parallel action jaws for secure attachment. The contoured plate is rubber lined to protect the hoop from nicks and scratches and to prevent slippage. The 75X features a slip-proof gear tilter and 7 8" tube for use with drum racks and adapters. The PPS-37 features a fully adjustable "L" arm for mounting cowbells, effects, and drums (with 3 8" receivers). The gear tilter grips securely and permits infinite angling possibilities. The integrated quick release bracket facilitates fast set-up and removal. The PPS-30 is a universal percussion mounting bracket that can be attached to any tubular stand with diameters of 3/4" to 1-1/8".



The CA-100 Hoop-Mounted Cowbell Holder features the same hoop clamp as the HA-100 but with a telescopic and tilting "L" arm for mounting cowbells and other percussion accessories with standard 3/8" attachment brackets.

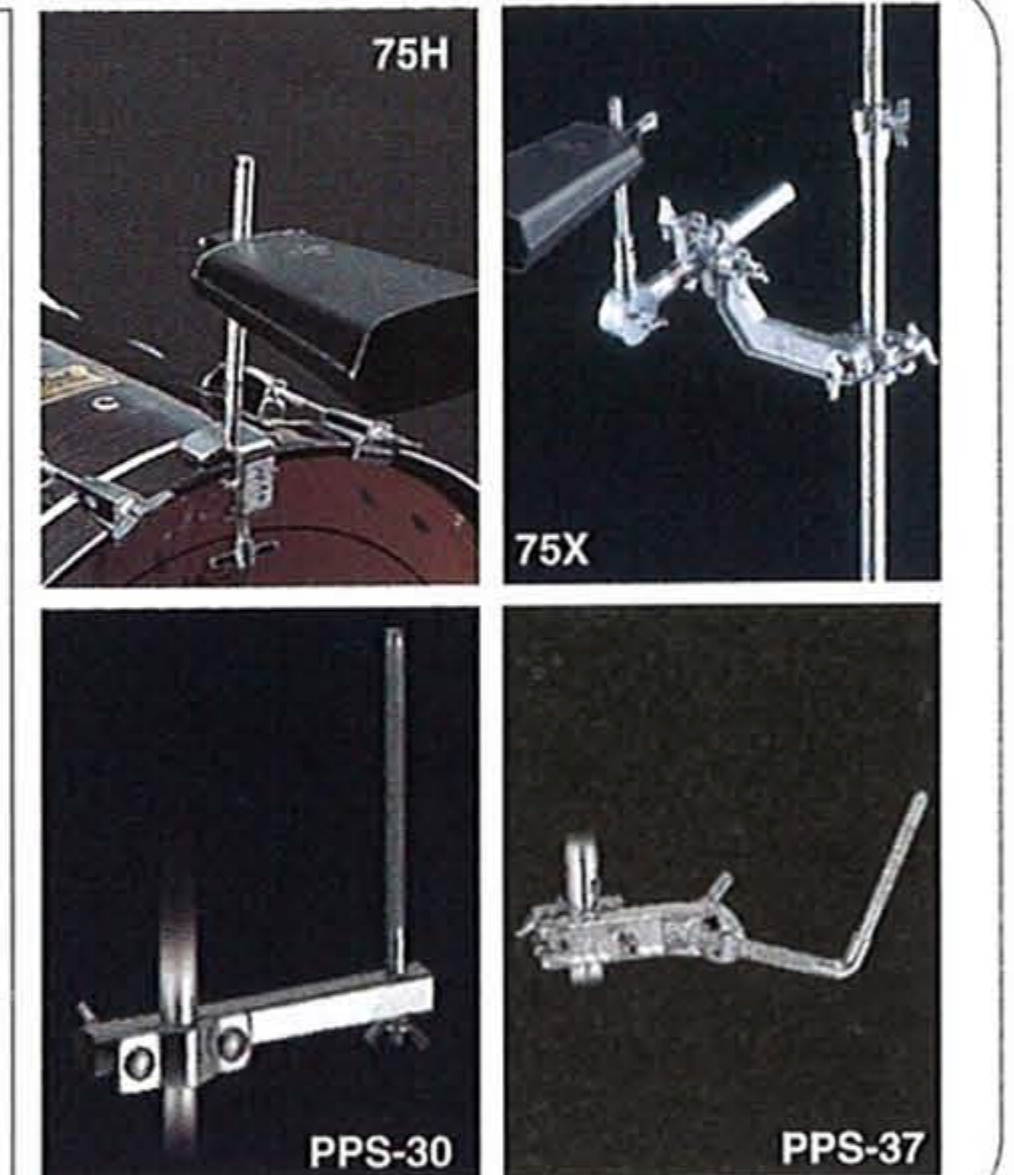

Tom Stands & Combination Stands

Pearl tom stands are available with gear-type or infinitely adjustable Uni-Lock tom holders, and all models feature double braced legs and AX-38 clamps with quick release jaws for the most secure grip possible. Our T-980W comes complete with two top of the line TH-100S tom holders. Our T-900W offers the same stability, but features our patented TH-98S tom holders. Our T-800W stand features deep-gear tilter tom holders. Our combination stands: TC-980W, TC-900W, and TC-800W offer both a tom and a cymbal holder providing an easy and compact alternative to the clutter of multiple single stands.

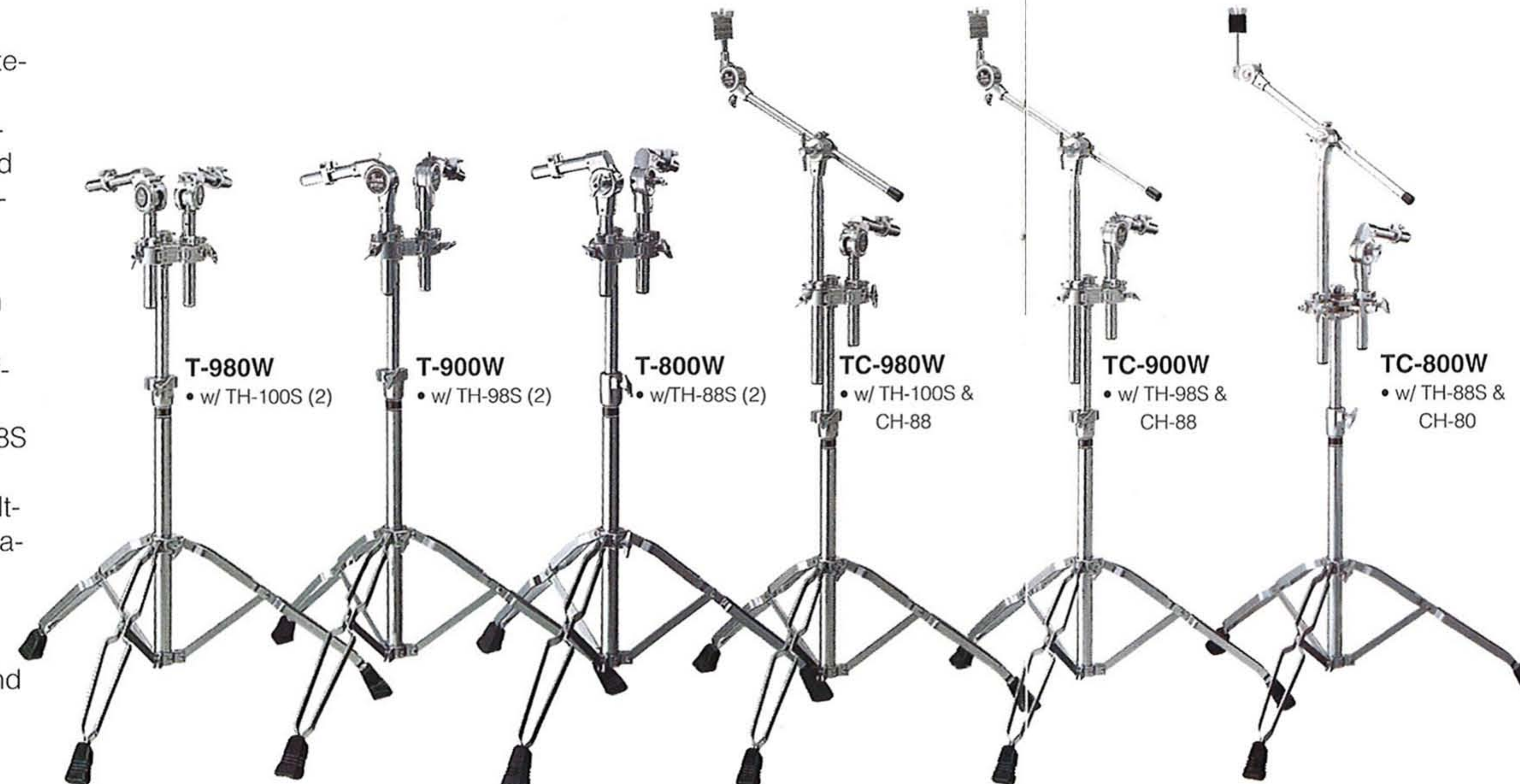

Tom Holders

Pearl tom holders are available with both our patented Uni-Lock (infinity adjustable) or gear-type tilters, and in both standard and short length versions. Our TH-100 series Uni-Lock Multi-Directional Tom Holder provides a super smooth, gear-less continuous feel and rotates both horizontally and vertically without changing the height or rotation within the bass drum or tom stand mount. Our TH-100I, TH-98I and TH-88I feature short arms for use with OptiMount or I.S.S. equipped toms.



Add-on Accessories

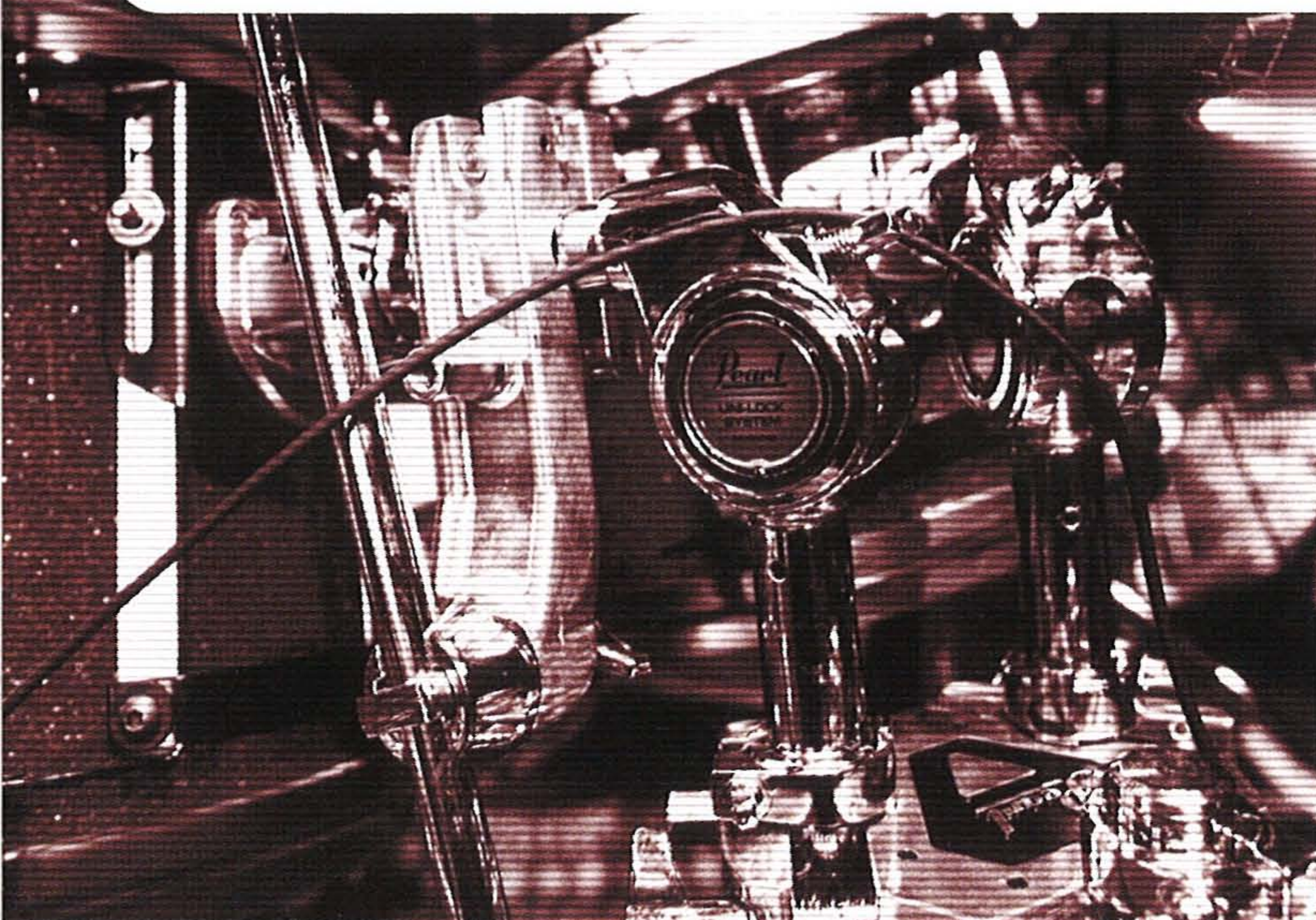

Jungle Gig

The JG-16 Jungle gig adapter from Pearl converts your floor tom into a bass drum without drilling holes or making permanent changes to the shell. The Jungle Gig adapter consists of two spurs, a height tube and a pedal mounting plate, and is designed to be used with the Pearl I.S.S. mount and BT-3 tom bracket. To make the conversion to an instant jungle - type drumset, simply turn the floor tom on its side, insert the legs into the leg brackets, attach the I.S.S. and pedal mounting plate to the hoop, and attach your pedal.



OptiMount Suspension System

Our OptiMount Suspension System attaches to the tom's tension rods and floats on rubber cushions, providing the ultimate in stability while allowing the drum to resonate fully unrestricted. With OptiMount, the mounting hardware is completely removed from the drum shell, providing a drastic improvement in resonance and sustain.



OPT-0708	Fits 7" to 8" depth toms.
OPT-0910	Fits 9" to 10" depth toms.
OPT-1112	Fits 11" to 12" depth toms.
OPT-1314	Fits 13" to 14" depth toms.
OPT-1516	Fits 15" to 16" depth toms.

Adapters

AX-20

The AX-20 features dual parallel clamps with quick release jaws. The jaws adjust to accommodate a wide range of tubing sizes.

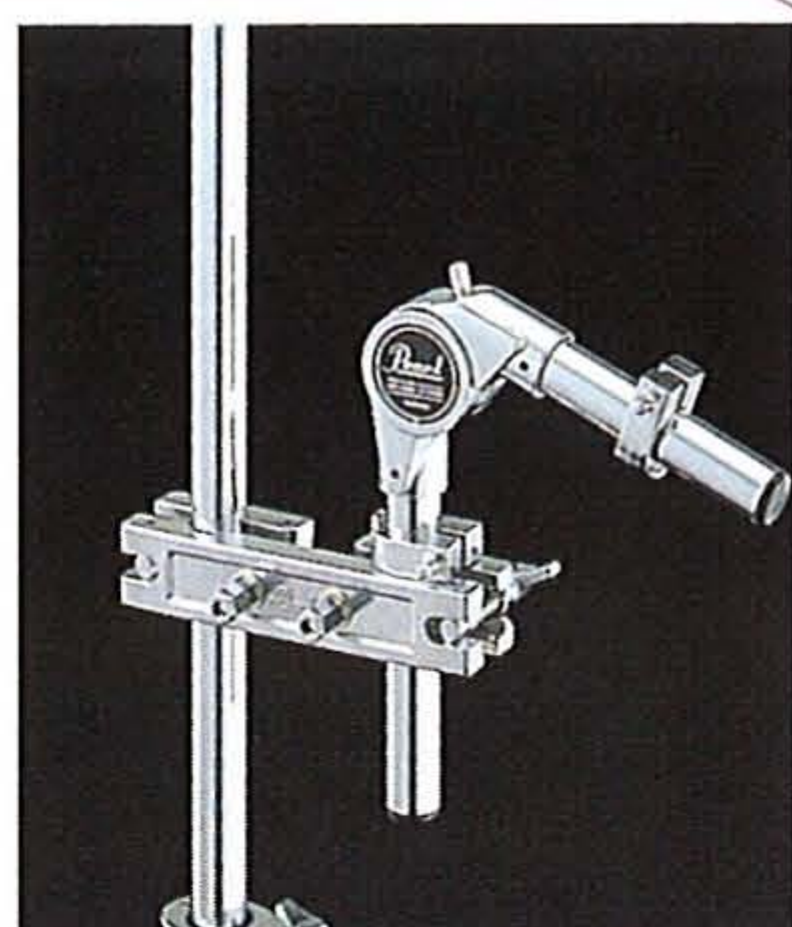
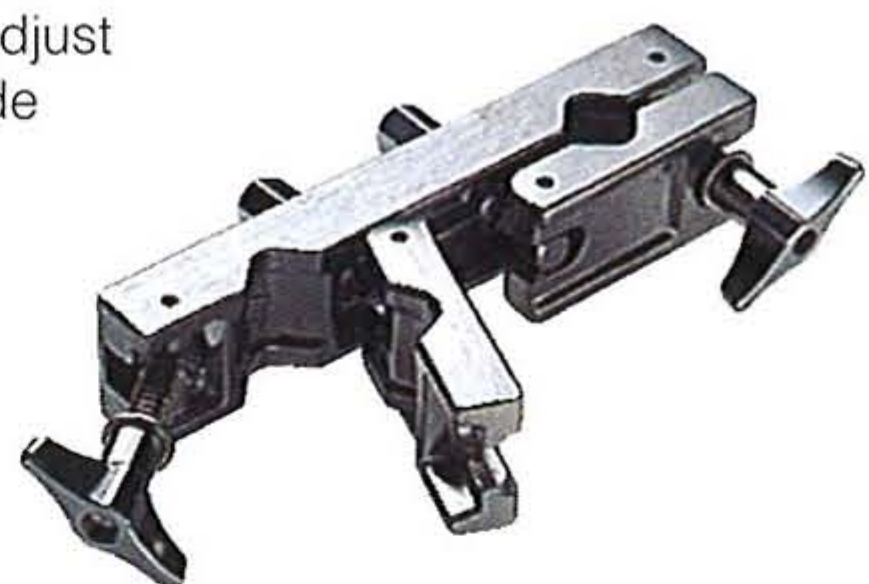

AX-28

Our AX-28 features a 360-degree rotating clamp and a stationary clamp combining the best features from the AX-20 and AX-25/25L. Both clamps are quick release and adjust to fit a wide range of tubing sizes.

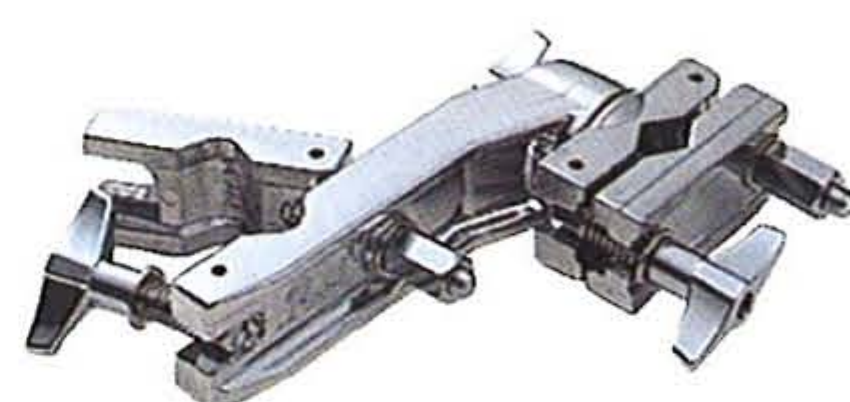

AX-25/25L

The AX-25 and AX-25L feature twin independently rotatable clamps for multi-angle applications. The clamps feature adjustable quick release jaws and gear tilters for non-slip security. The AX-25L features a longer arm for extended reach.

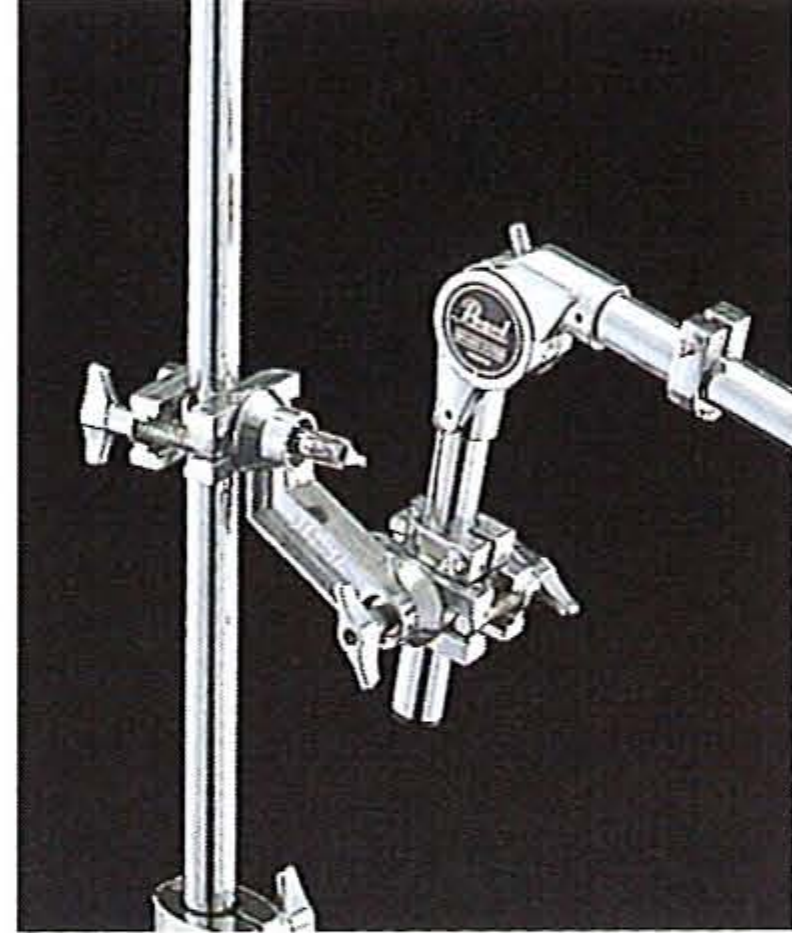

AX-38 NEW

The new AX-38 three-hole adapter features 3 hinged quick release jaws each capable of adjusting from 3/8" to 1 1/4" for versatile and super quick attachment/removal of holders from virtually any brand. The AX-38 is standard on all Pearl tom stands and offers notches for our SX-2 Stop-Locks.

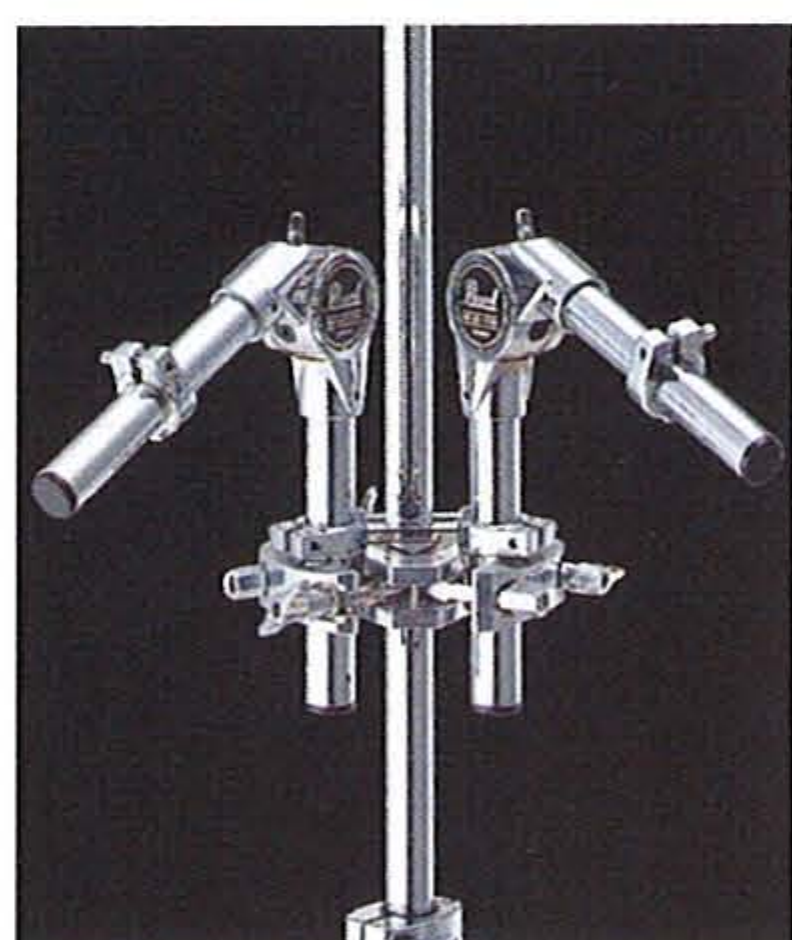
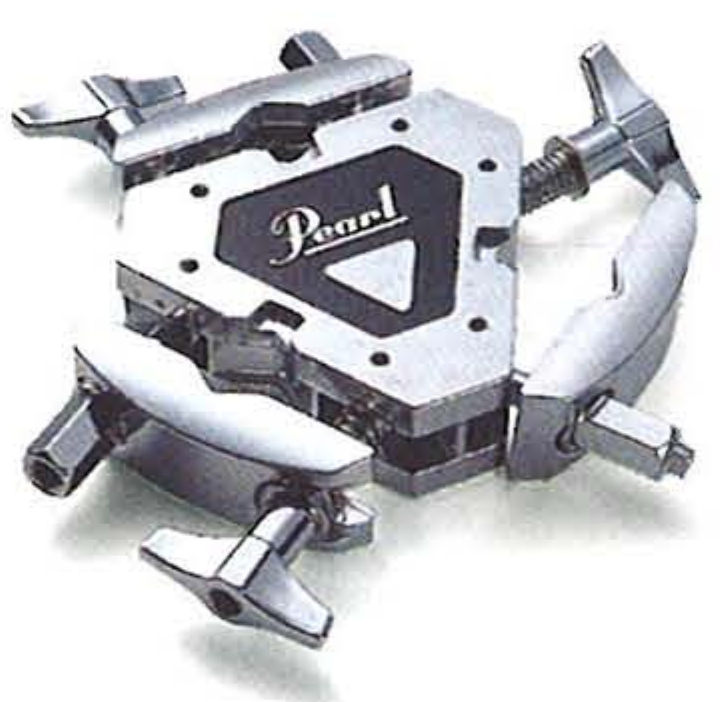

I.S.S. Integrated Suspension System

Our standard I.S.S. mounts also remove all mounting hardware from the shell and clamp to the rim providing the quickest, easiest mounting system available today. (US.PAT. 5544561)

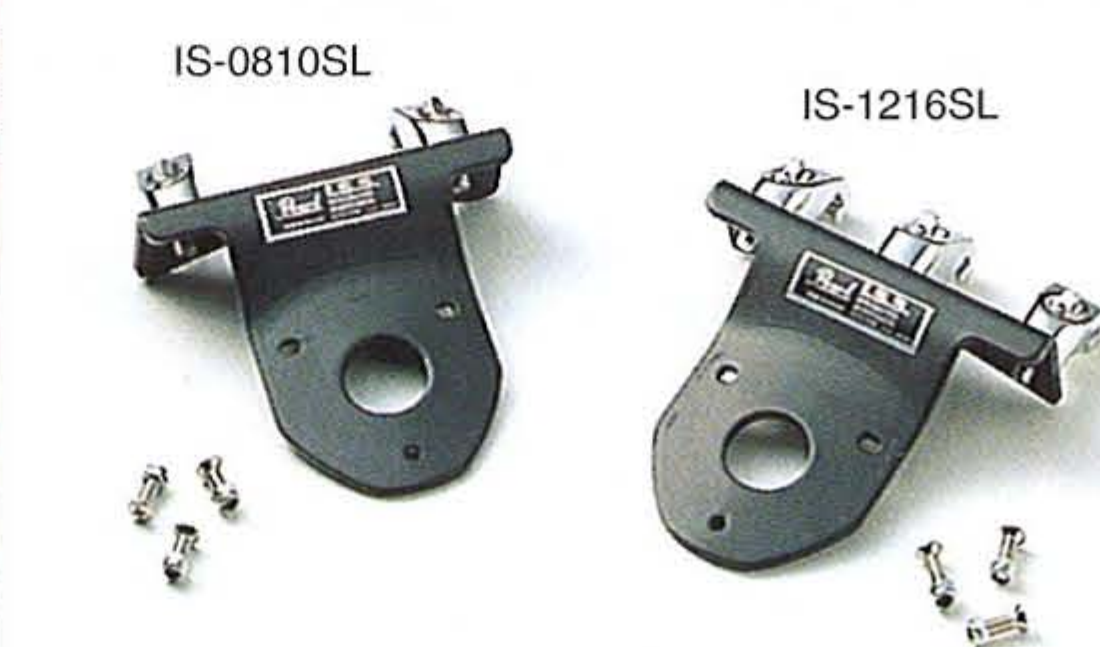

IS-0810N	Fits 8" to 10" 1.6mm steel hoops and original Super hoops.
IS-1216N	Fits 12" to 16" 1.6mm steel hoops.
IS-0810SL	Fits 8" to 10" 2.0mm steel/stainless steel hoops and 2.3mm Super Hoop II.
IS-1216SL	Fits 12" to 16" 2.0mm steel/stainless steel and 2.3mm Super Hoop II.

Genuine Replacement Parts



Bass Drum Spurs



The SP-30 features "set and forget" fold away spurs with twist-lock retractable spike/rubber tips. Sold in sets of two.



SP-30

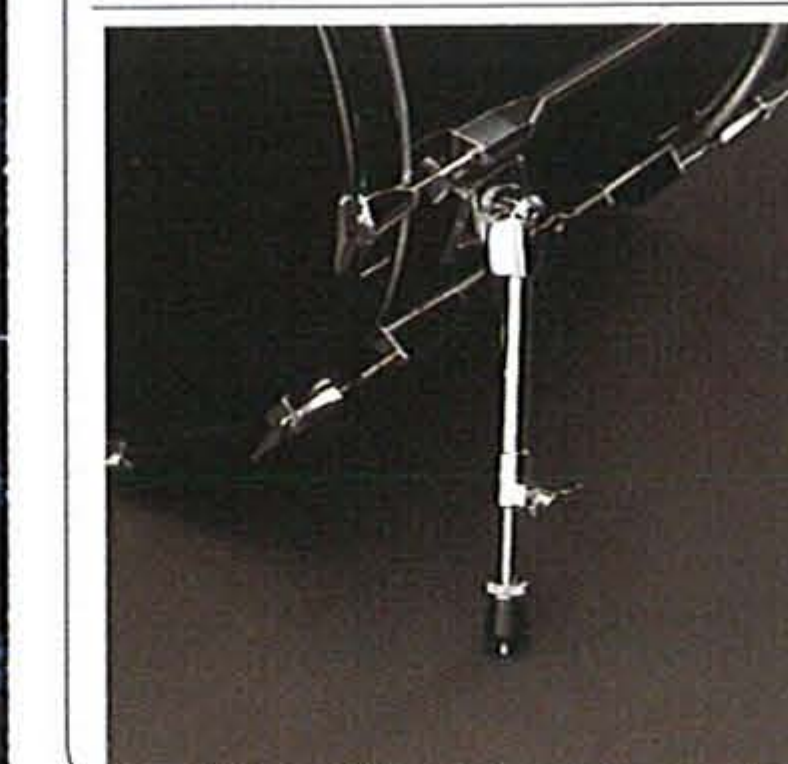

SP-20 spurs feature fold away telescopic points with spike/rubber tips. Sold in sets of two.



SP-20

Bass Drum Hoops



RIM-22W	Pearl bass drum hoops feature premium 8 ply maple construction and super high gloss lacquer finishes. Sizes : 18" to 24".
RIM-22RB	Steel bass drum hoops feature black lacquer finish and a choice of color inlays. Size : 18" to 24"
NP-01	The NP-01 installs in the channel of steel bass drum hoops and provides a slip-resistant surface for bass drum pedals.

Bass Drum Tension Rods & Claw Hooks



T-075	Die-cast tension handle bolt (M6 x 110mm)
T-066	Key rod for bass drum (M6 x 110mm)
D-054	Die-cast claw hook (Masters)
D-050	Die-cast claw hook
D-043	Claw hook (Export Select / Export)

Bass Drum Rubber Tips



R-30A/2	Rubber tips for SP-30 spurs. Sold in pairs.
RHS-1R/2	Rubber tips for SP-20 spurs. Sold in pairs.

Bass Drum Bracket



The BB-3 accepts all tom holders and accessories using 7/8" tubing. The BB-3's dual brackets feature slip resistant nylon sleeves and fit SX-2 Stop-Locks.

Floor Tom Leg & Bracket



LB-40	Masters floor tom leg bracket.
LG-40/3	Floor tom leg featuring the Air Suspension rubber tip. Sold in packs of 3.
LB-15	Floor tom leg bracket, standard.
LG-07/3	NEW Floor tom leg. Sold in packs of 3.

Tom Tom Bracket



The BT-3 accepts all holders using 7/8" tubing and features an internal non-marring nylon sleeve for slip resistance. Accepts SX-2 Stop-Locks.

BT-3

Masking Cover

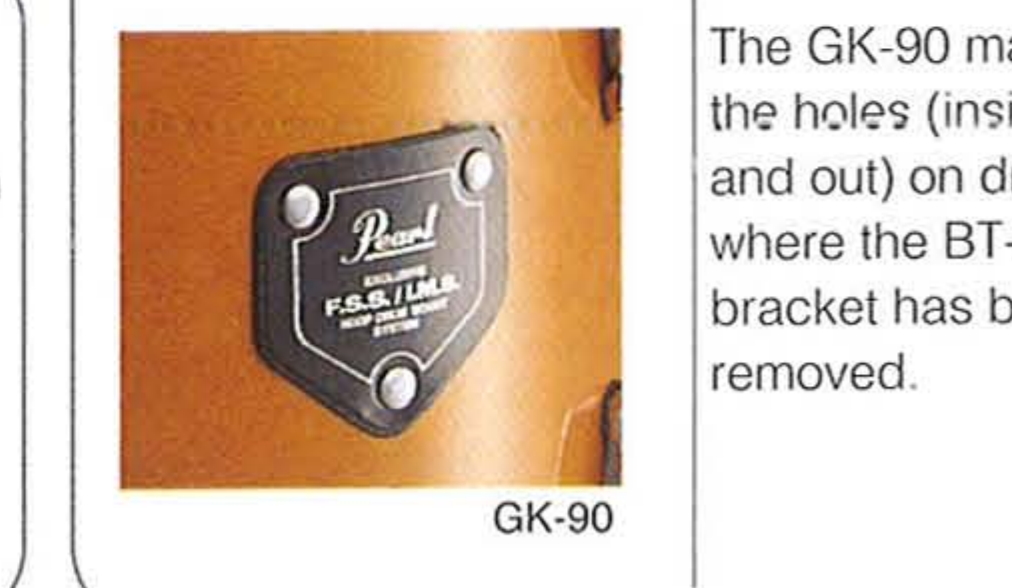

The GK-90 masks the holes (inside and out) on drums where the BT-3 tom bracket has been removed.

GK-90

Floor Tom Rubber Tips



R-40/3	Air Suspension rubber tips (US. PAT. 5881981). Substantially improves sustain and resonance of floor toms. Fits all 3/8" diameter floor tom legs. (Sold in packs of 3)
R-5/3	Soft compound rubber tip for 782 floor tom legs. (Sold in packs of 3)

Genuine Replacement Parts



High Carbon Steel Snares & Steel Wound Wire

Pearl snares feature high-carbon steel wires for extreme sensitivity and superior durability. Precision manufacturing guarantees snares that are completely flat for total drumhead contact. S-040 and S-041 wire wound snares are ideal for applications requiring a drier, darker sound than wire snares.

SPS-18
Replacement snare
straps
(Sold in packs of 6)

SNC-40
Our snare string is
specially made with
200 strands of Dacron
for incredible
stretch resistance.
Sold in packs of 6.

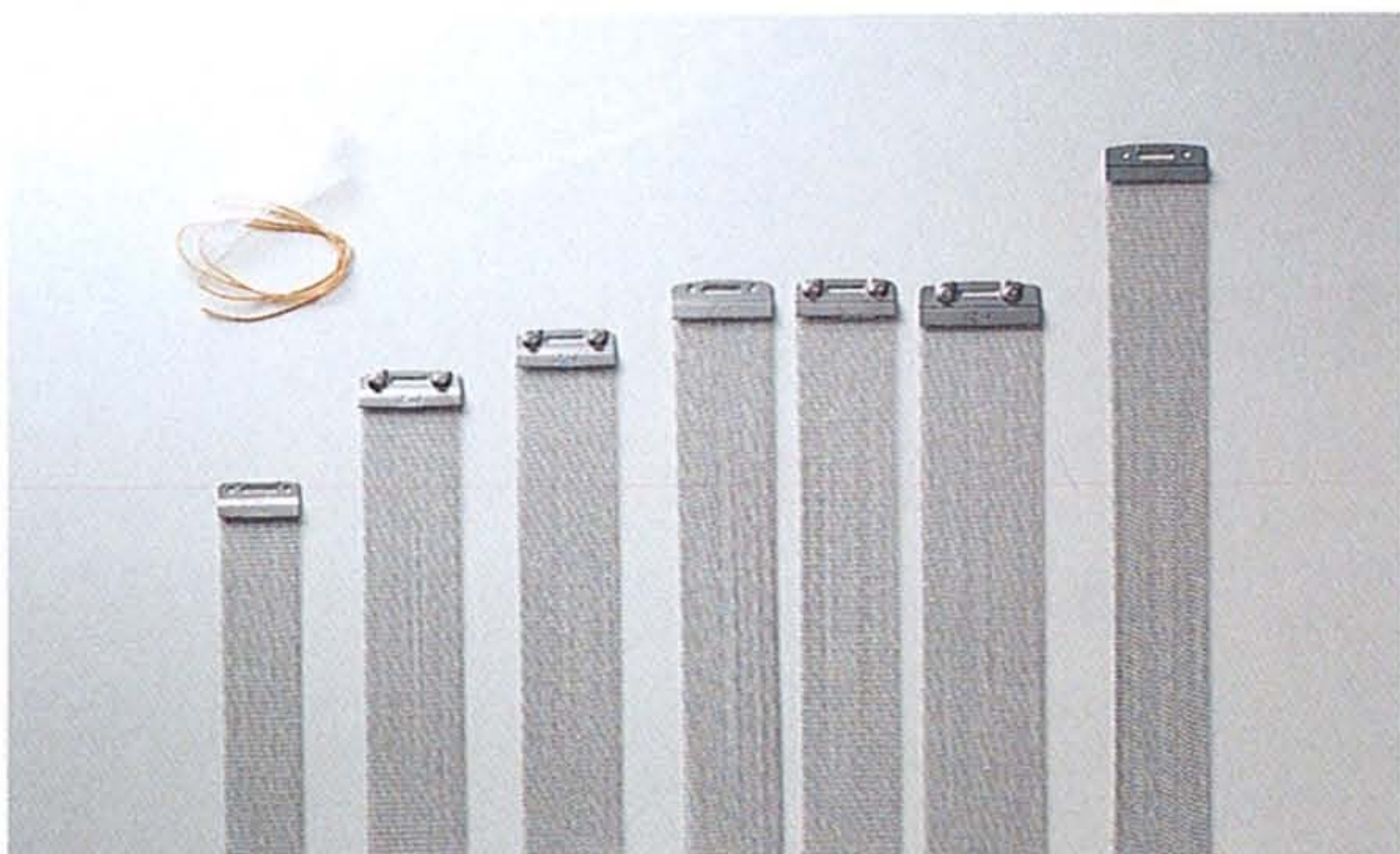

Model #	Strands	For	Material
S-022	20	14"	High Carbon Steel
S-022N	20	14"	High Carbon Steel
S-022NU	20	14"	High Carbon Steel
S-025	20	14"FFS	High Carbon Steel
S-029N	20	13"	High Carbon Steel
S-030N	24	14"	High Carbon Steel
S-031N	20	12"	High Carbon Steel
S-032N	12	10"	High Carbon Steel
S-033N	12	12"	High Carbon Steel
S-040	15	14"	Steel Wire Wound, thinner gauge
S-041	15	14"	Bronze Wire Wound, thicker gauge

MasterCast Hoop

MasterCast are the finest die cast hoops available and feature the perfect blend of thickness and mass to improve the depth, clarity, and focus of toms and snare drums.

Model #	Diameter	Tension
DC-0805	8"	5
DC-1006	10"	6
DC-1206	12"	6
DC-1306	13"	6
DC-1408	14"	8
DC-1408S	14"	8 snare side
DC-1410	14"	10
DC-1410S	14"	10 snare side
DC-1410SG	14"	10 snare side w/guard
DC-1508	15"	8
DC-1608	16"	8
DC-1808	18"	8

Super Hoop II

SuperHoop II are precision formed from heavy-duty 2.3mm steel, triple-flanged and engraved with the SuperHoop II logo.

Model #	Diameter	Tension
SH-0805	8"	5
SH-1006	10"	6
SH-1206	12"	6
SH-1306	13"	6
SH-1408	14"	8
SH-1410	14"	10
SH-1410S	14"	10 snare side
SH-1410SG	14"	10 snare side w/guard
SH-1508	15"	8
SH-1608	16"	8
SH-1808	18"	8

Steel Hoop

Model #	Diameter	Tension	Model #	Diameter	Tension
RIM-0604	6	4, Batter Side	RIM-1308S	13	8, Snare Side
RIM-0804	8	4, Batter Side	RIM-1406	14	6, Batter Side
RIM-0805	8	5, Batter Side	RIM-1408B	14	8, Batter Side
RIM-1006	10	6, Batter Side	RIM-1408S	14	8, Snare Side
RIM-1006SL	10	6, Snare Side	RIM-1410B	14	10, Batter Side
RIM-1206	12	6, Batter Side	RIM-1410S	14	10, Snare Side
RIM-1206SL	12	6, Snare Side	RIM-1410SG	14	10, Snare Side /guard
RIM-1208B	12	8, Batter Side	RIM-1508	15	8, Batter Side
RIM-1208S	12	8, Snare Side	RIM-1606	16	6, Batter Side
RIM-1306	13	6, Batter Side	RIM-1608	16	8, Batter Side
RIM-1308B	13	8, Batter Side	RIM-1808	18	8, Batter Side

Drum Keys

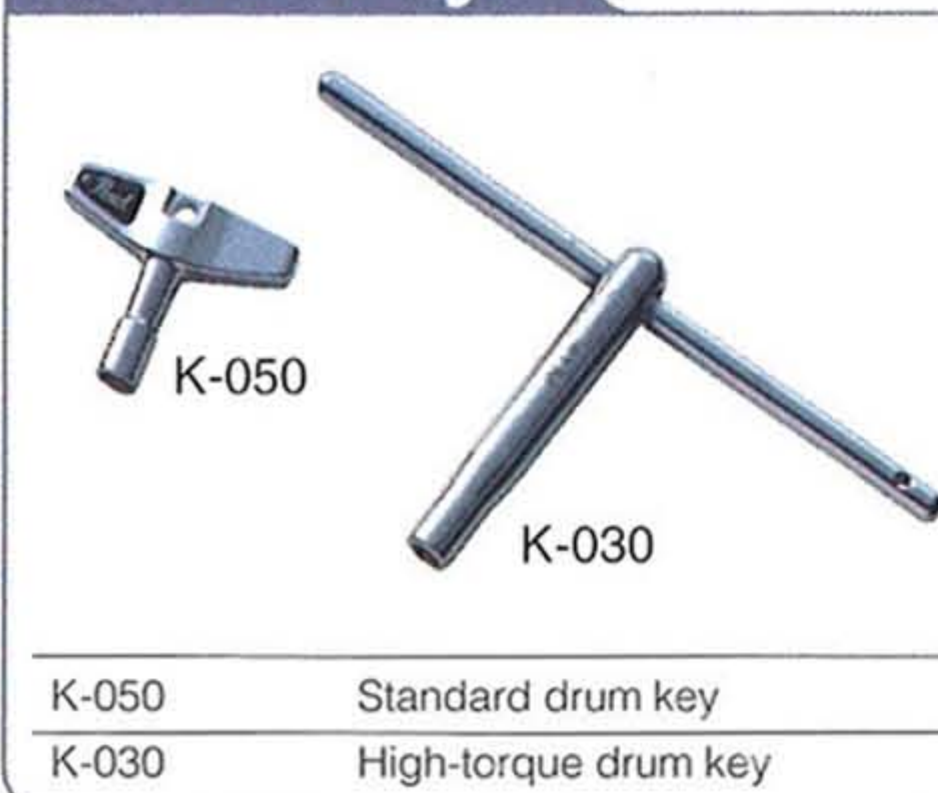

K-050 Standard drum key
K-030 High-torque drum key

Snare Basket Adapter



SBA-1/3

The SBA-1 allows 12" snare drums, such as the M-1270 to fit all Pearl snare stands. Sold in sets of three.

Strainers

Pearl strainers feature Vertical Pull action for ideal snare-to-head contact head using minimal tension. This results in superior snare response at all volume levels.



SR-010	For Free Floating System snare drums. Butt-side tension adjustment helps center snares. Package includes strainer and butt.
SR-012	Features side-action lever and 3-hole bolt pattern. Package includes strainer and butt.
SR-015	Gladstone-type strainer features drop-type lever and 3-hole bolt pattern. Package includes strainer and butt.
SR-017	Vintage-style side-action lever and 2-hole bolt pattern. Package includes strainer and butt.
SR-018	Mini vintage-style side-action lever and 2-hole bolt pattern. Package includes strainer and butt.
SR-020	Multi-trace strainer features click-stops for instant changes from tight, medium and loose snare settings. Package includes strainer and butt. (US.PAT. 5684257)

Outside Muffler

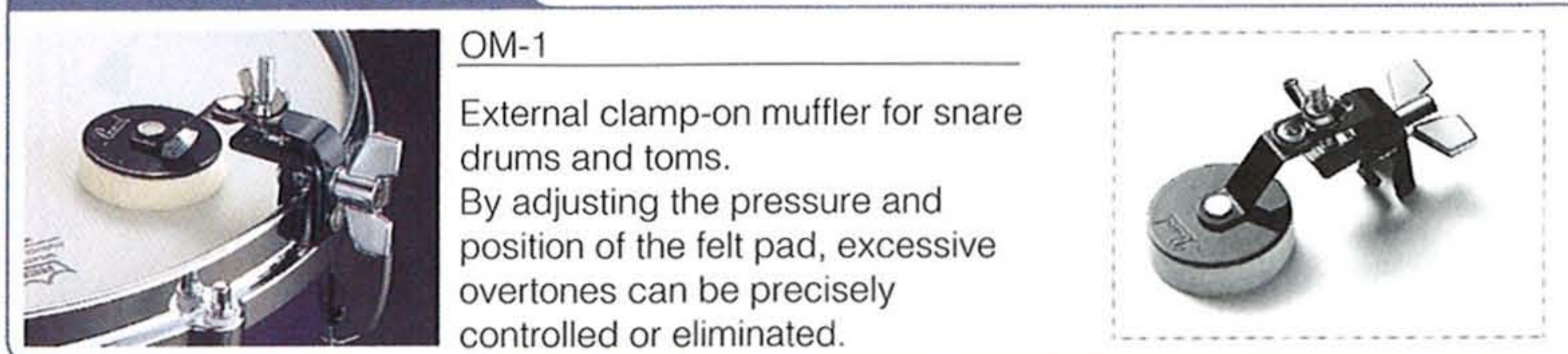

OM-1

External clamp-on muffler for snare drums and toms. By adjusting the pressure and position of the felt pad, excessive overtones can be precisely controlled or eliminated.

"Precision-fit" Stainless Steel Tension Rods



Pearl's Stainless Steel Tension Rods are machined, not forged, from a single piece of stainless steel to the most exacting tolerances in the industry. They feature super-smooth, precise tensioning, with absolutely no play. Each non-plated stainless steel tension rod is matched with a precision-machined brass swivel nut for ultra-precise metal-to-metal performance.

SST-5028/6	M5.8 x 28mm	SST-5028/6	M5.8 x 28mm
SST-5038/6	M5.8 x 38mm	SST-5038/6	M5.8 x 38mm
SST-5042/6	M5.8 x 42mm	SST-5042/6	M5.8 x 42mm

Tension Rods & Washers

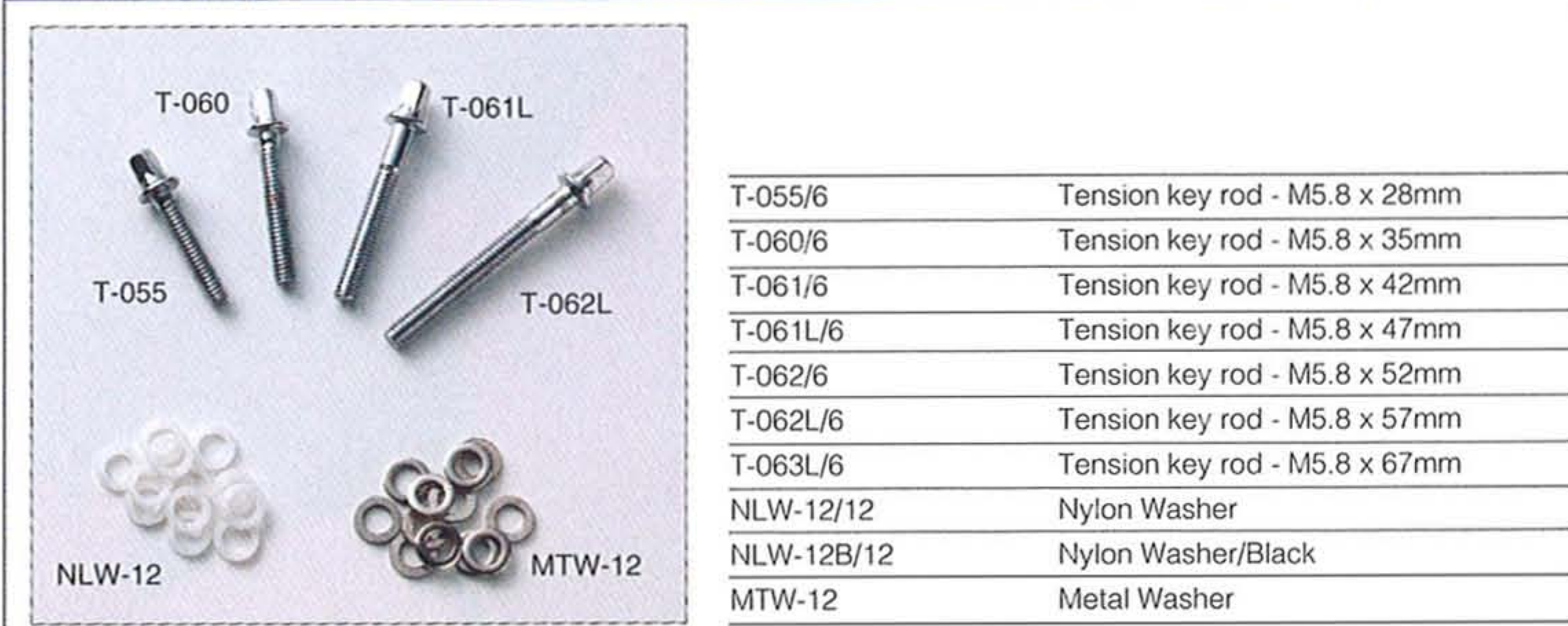

T-055/6	Tension key rod - M5.8 x 28mm
T-060/6	Tension key rod - M5.8 x 35mm
T-061/6	Tension key rod - M5.8 x 42mm
T-061L/6	Tension key rod - M5.8 x 47mm
T-062/6	Tension key rod - M5.8 x 52mm
T-062L/6	Tension key rod - M5.8 x 57mm
T-063L/6	Tension key rod - M5.8 x 67mm
NLW-12/12	Nylon Washer
NLW-12B/12	Nylon Washer/Black
MTW-12	Metal Washer

Aluminum Drive Shaft

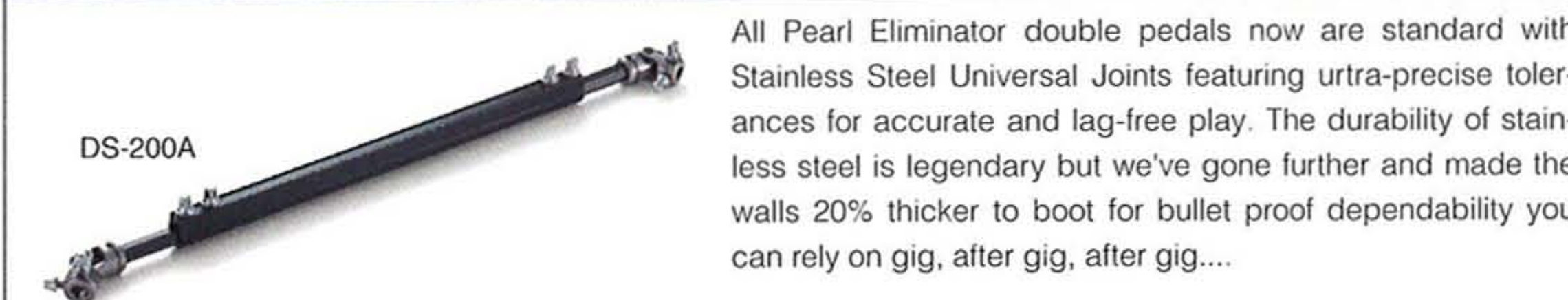

All Pearl Eliminator double pedals now are standard with Stainless Steel Universal Joints featuring ultra-precise tolerances for accurate and lag-free play. The durability of stainless steel is legendary but we've gone further and made the walls 20% thicker to boot for bullet proof dependability you can rely on gig, after gig, after gig...

Springs



SP-31
Standard Spring (1.5mm)
SP-64
Spring for Eliminator (1.7mm)

Key Bolts



KB-508/6	M5 x 8mm for universal joint
KB-512/6	M5 x 12mm for mounting belt
KB-608/6	M6 x 8mm for powerfilter
KB-610/6	M6 x 10mm for drive shaft
KB-630A	M6 x 30mm for uni-lock beater angle adjustment
KB-814/3	M8 x 14mm for beater holder link

Hi-Hat Clutches

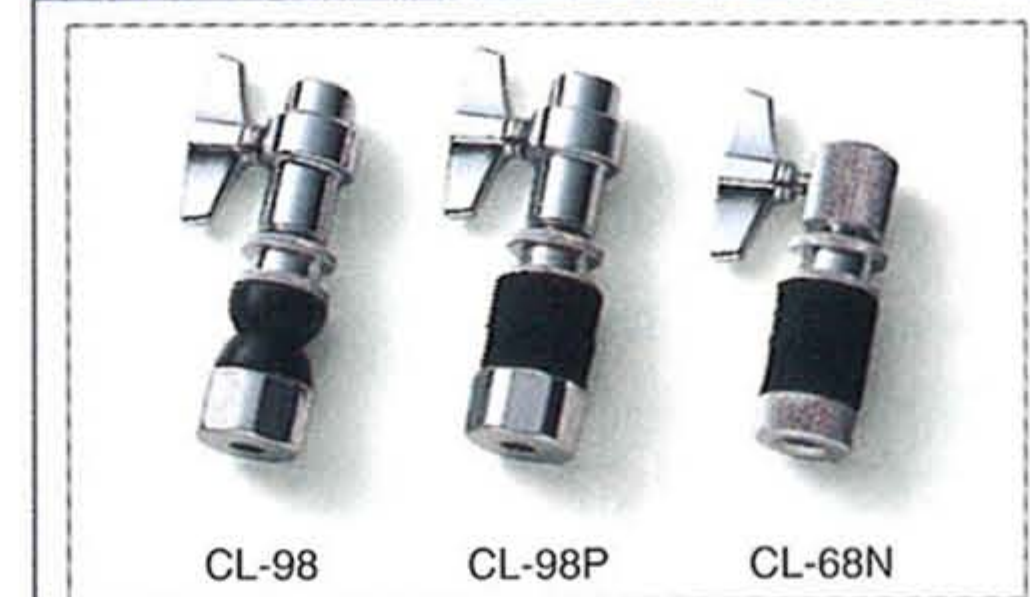

CL-98 CL-98P CL-68N

CL-98 / CL-98P
CL-98/98P hi-hat clutches feature Pearl's Triple-Lock system for non-slip performance. The CL-98P features minimal contact rubber washers for improved clarity and increased volume of hi-hat cymbals.
CL-68N
Basic hi-hat clutch with die-cast wing bolt.

Hi-Hat Upper Section

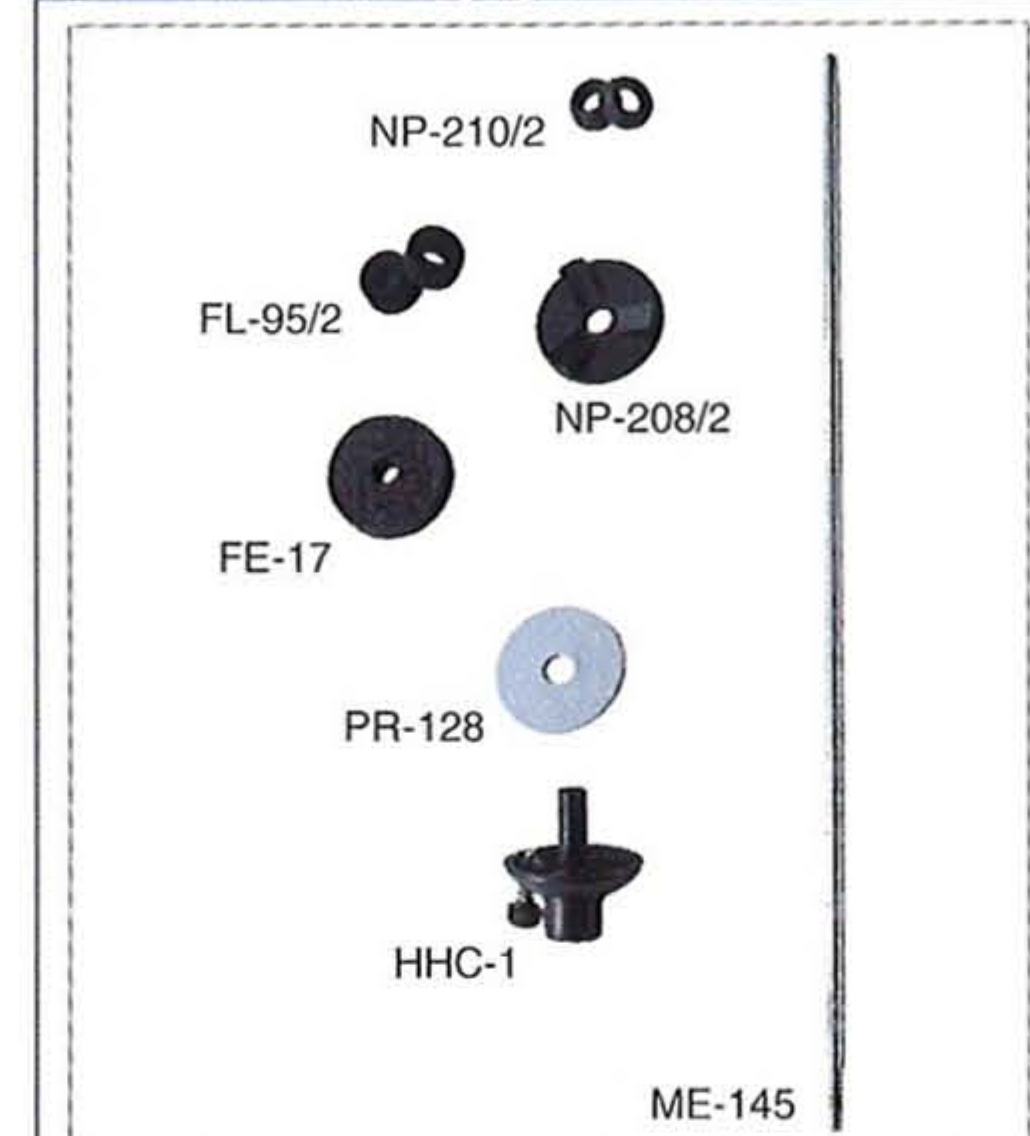

NP-208/2
The NP-208/2 incorporates minimal-contact ridges to suspend the bottom cymbal for noticeably improved clarity and sustain. Fits all hi-hat stands.
NP-210/2
The NP-210/2 features minimal-contact conical-shaped rubber washers for improved clarity and "chick" sound of all hi-hat cymbals. Sold in sets of 2.
FE-17
Standard bottom felt washer.
FL-95/2
Standard felt clutch washers. Sold in sets of 2.
PR-128
Steel bottom washer.
HHC-1
Hi-hat seat cup with tilter screw and spring.
ME-145
7mm dia. top pull rod. Fits most hi-hat stands.

Cymbal Tilters

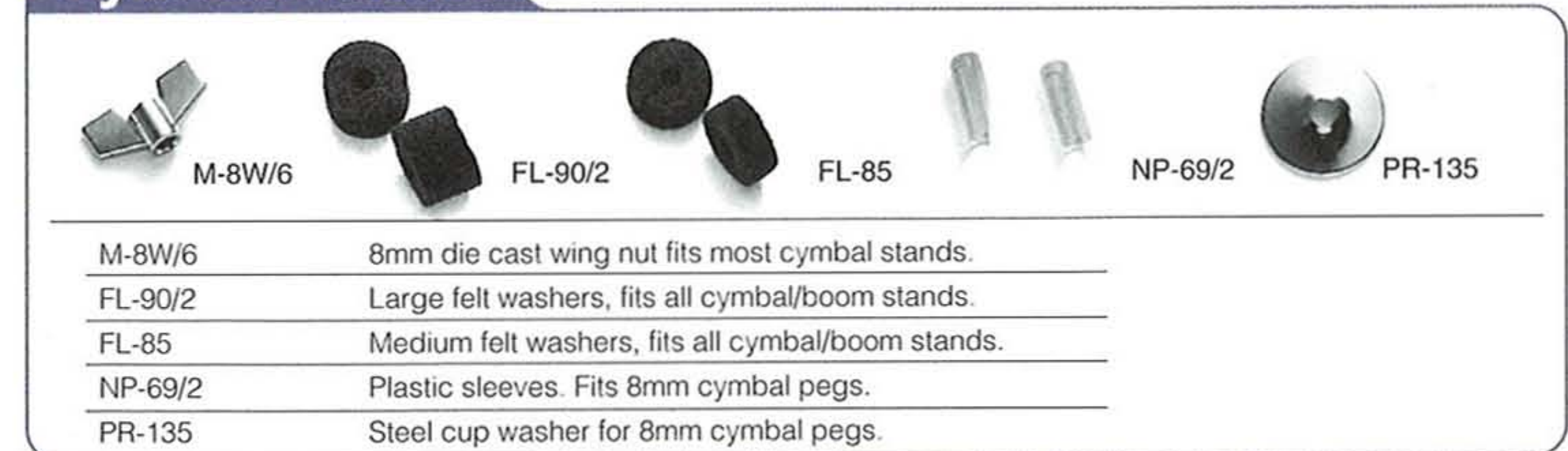

M-8W/6	8mm die cast wing nut fits most cymbal stands.
FL-90/2	Large felt washers, fits all cymbal/boom stands.
FL-85	Medium felt washers, fits all cymbal/boom stands.
NP-69/2	Plastic sleeves. Fits 8mm cymbal pegs.
PR-135	Steel cup washer for 8mm cymbal pegs.

Bolt and Nuts

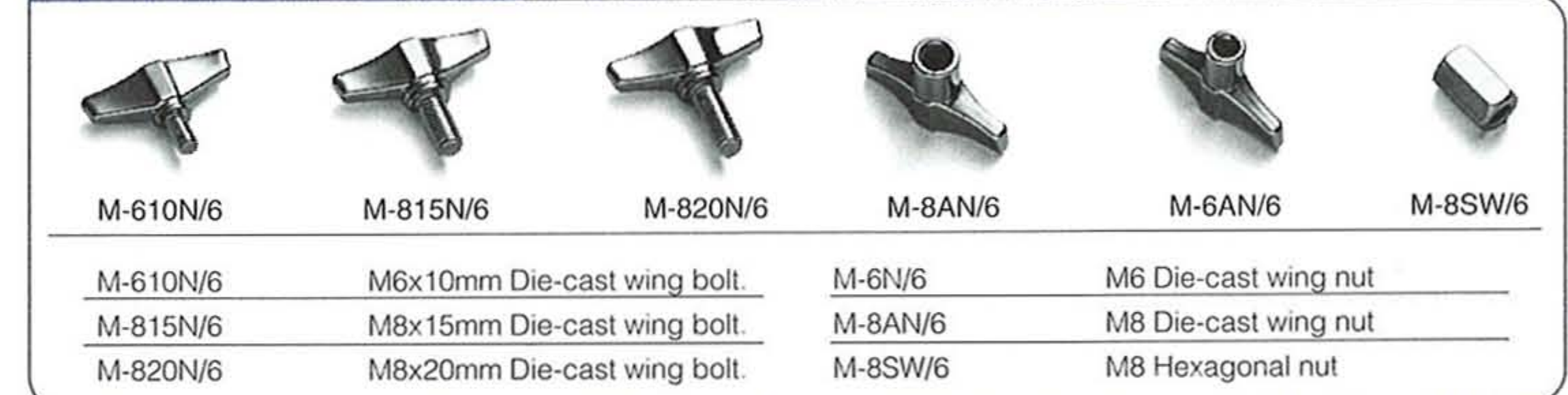

M-610N/6	M6x10mm Die-cast wing bolt.	M-6N/6	M6 Die-cast wing nut
M-815N/6	M8x15mm Die-cast wing bolt.	M-8AN/6	M8 Die-cast wing nut
M-820N/6	M8x20mm Die-cast wing bolt.	M-8SW/6	M8 Hexagonal nut

Rubber Tips

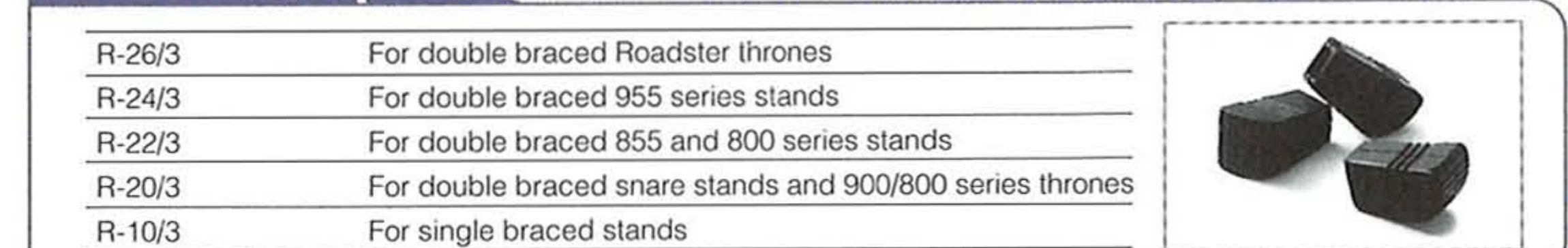

R-26/3	For double braced Roadster thrones
R-24/3	For double braced 955 series stands
R-22/3	For double braced 855 and 800 series stands
R-20/3	For double braced snare stands and 900/800 series thrones
R-10/3	For single braced stands

Practice Kits

Training Drum Kits



TK-100

The TK-100 is a compact practice kit with rack-type styling for flexibility and realistic positioning. The TK-100's rubber pads are extremely quiet and perfect for use in "sound-sensitive" environments.

Training Drum Pad

SD-50H

The SD-50 features Pearl's unique rubber pad surface with realistic rebound and near silent performance. The stand and pad use heavy-duty 8mm threading for superior durability and stability.

Bass Drum Pedal Training Pad

BD-10

The BD-10 bass pad is perfect for practicing at home or on the road. The wide pad accommodates double pedals and is specially formulated for extremely low noise and a realistic feel. The universal-fit "hoop" accepts all brands of pedals and adjusts to compensate for different floor surfaces. The BD-10 folds for compact transport.

Silencer Rubber Pad

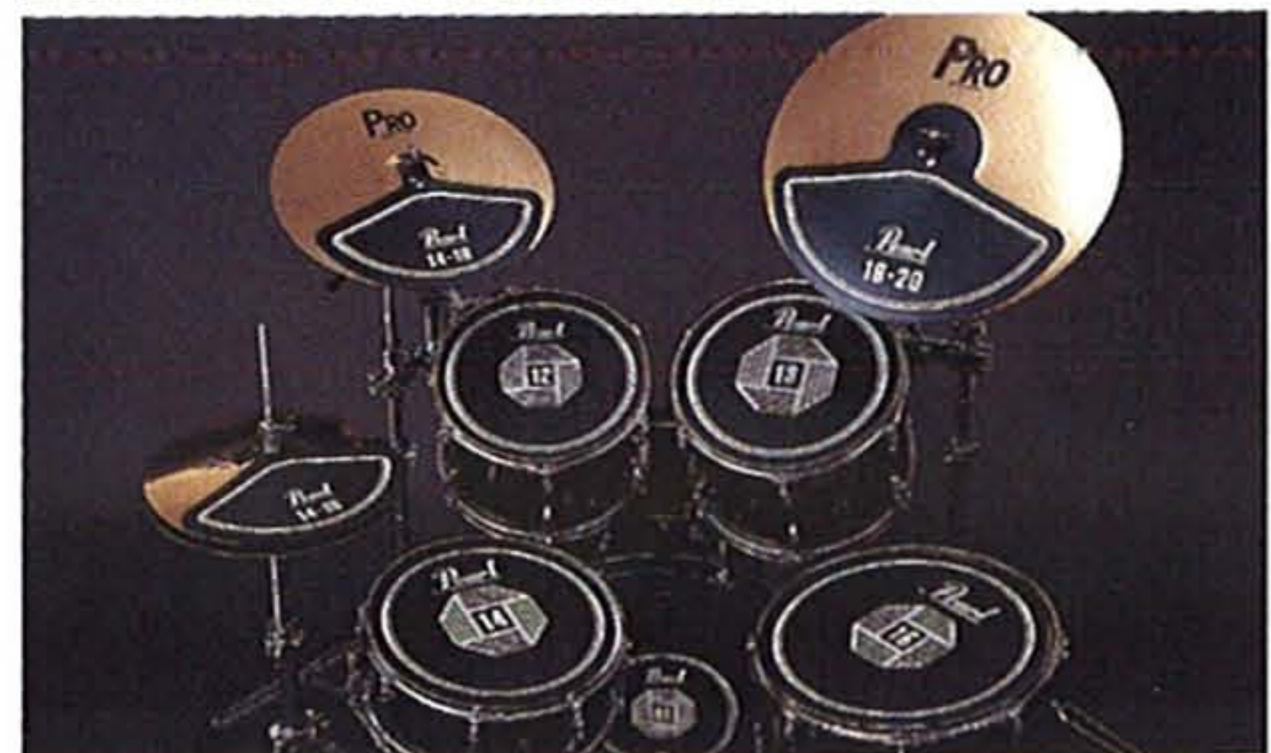

RP-50

Our RP-50 features five rubber discs for silent practicing on drumsets with 12", 13", and 16" toms, and 14" snare drum. A universal-fit bass pad with adjustable straps is also included. They remove easily for resumption of live play.

RP-40C

Our RP-40C silencers dramatically reduce the sound levels of your cymbals for silent practicing. Consists of two 18"/20" cymbal pads and a pair for 14" hi-hats.

Pearl

PERCUSSION

An artist puts his heart, mind and soul into every beat of every song he plays. His sound is complicated. Part instrument, part player, and part emotion. We make the drums that return all the emotions you give. The drums that help you create a sound as individual as you are. At Pearl, we've been producing the world's finest drums since the 1940's.

You've seen them on stages all across the world, played by the true stars of every type of music imaginable. We listen to players.

Both to what they say, and to the voice that speaks when they play. The instruments on the following pages represent our commitment to the percussionists of the world.

They are in fact their drums. They offer a sound and character that can set your emotions free, and a quality of instrument that only the largest manufacturer of percussion equipment in the world can deliver.

Whether you are a beginner, or a seasoned pro, a quality instrument will change the way you play forever.

If you have the heart, mind and soul of a player, then you have what it takes to play Pearl.



Bela Fleck

Future Man

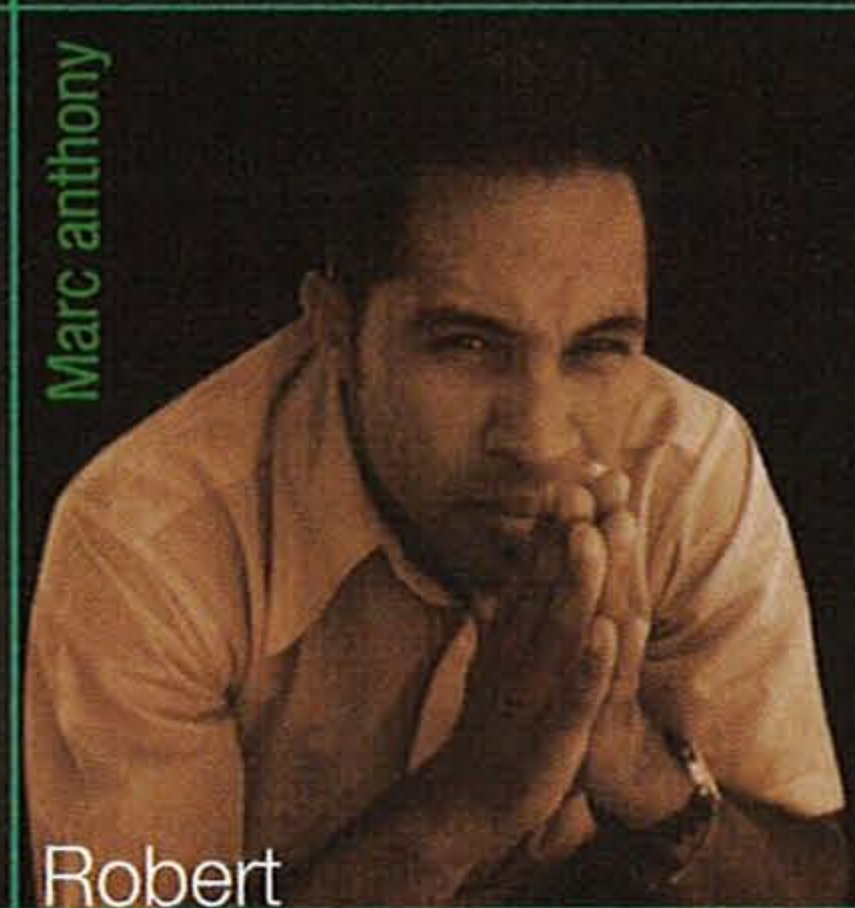

Marc Anthony

Robert Vilerá

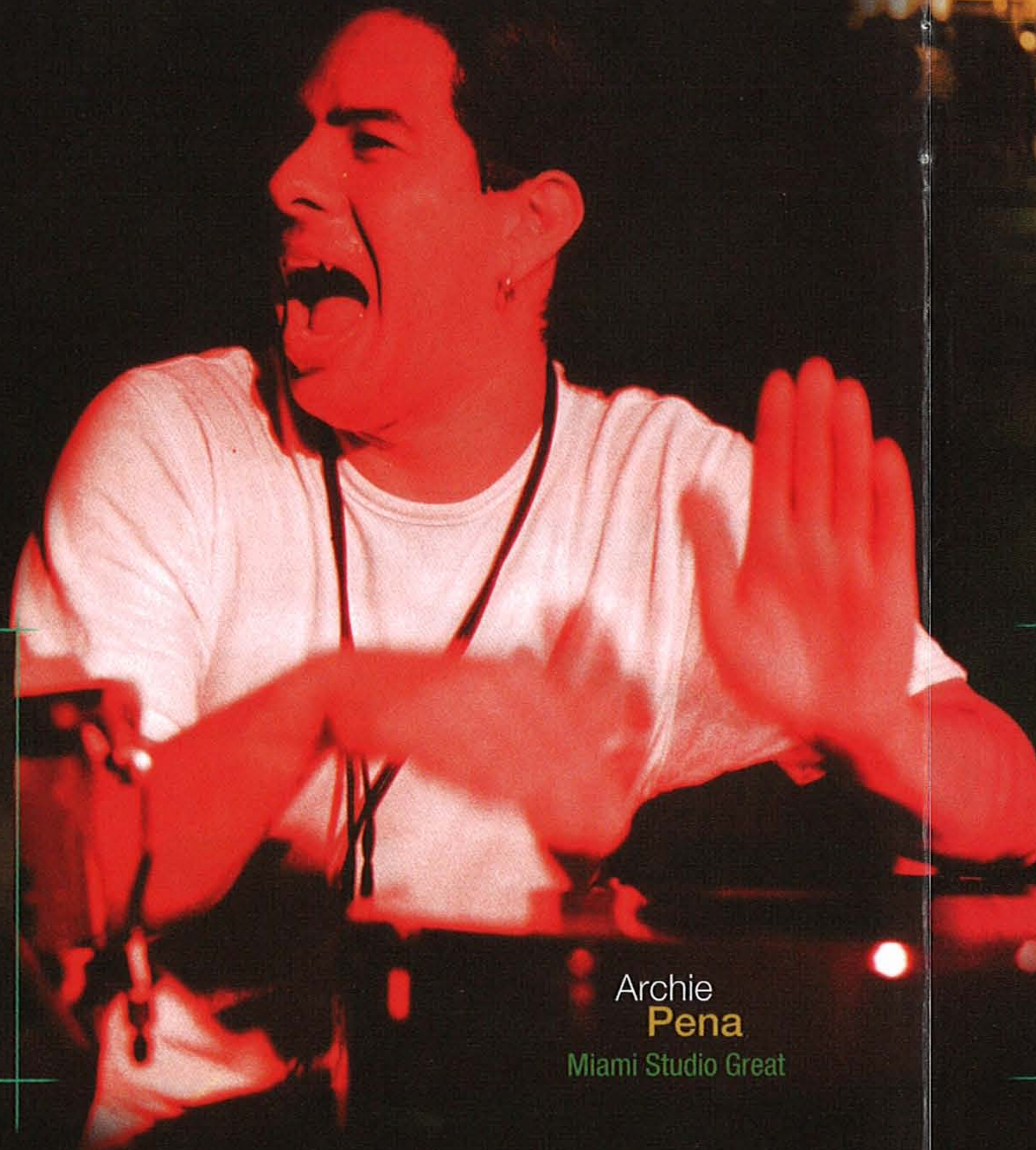

Archie Pena
Miami Studio Great



Lalo Davila
Percussion Educator and Clinician

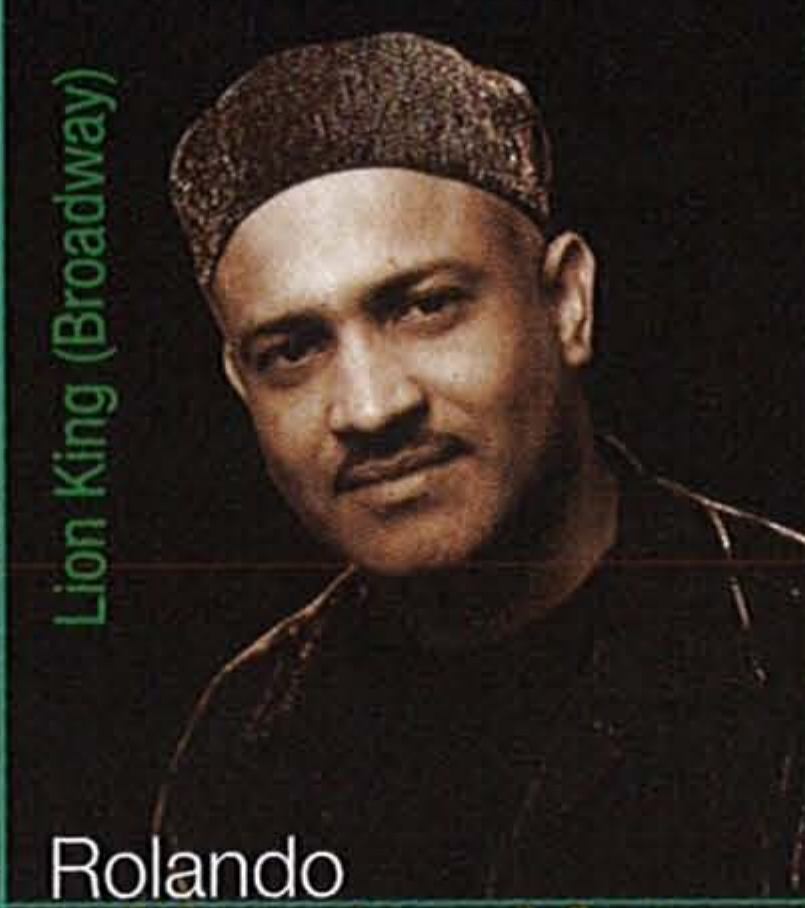

Lion King (Broadway)

Rolando Morales-Matos

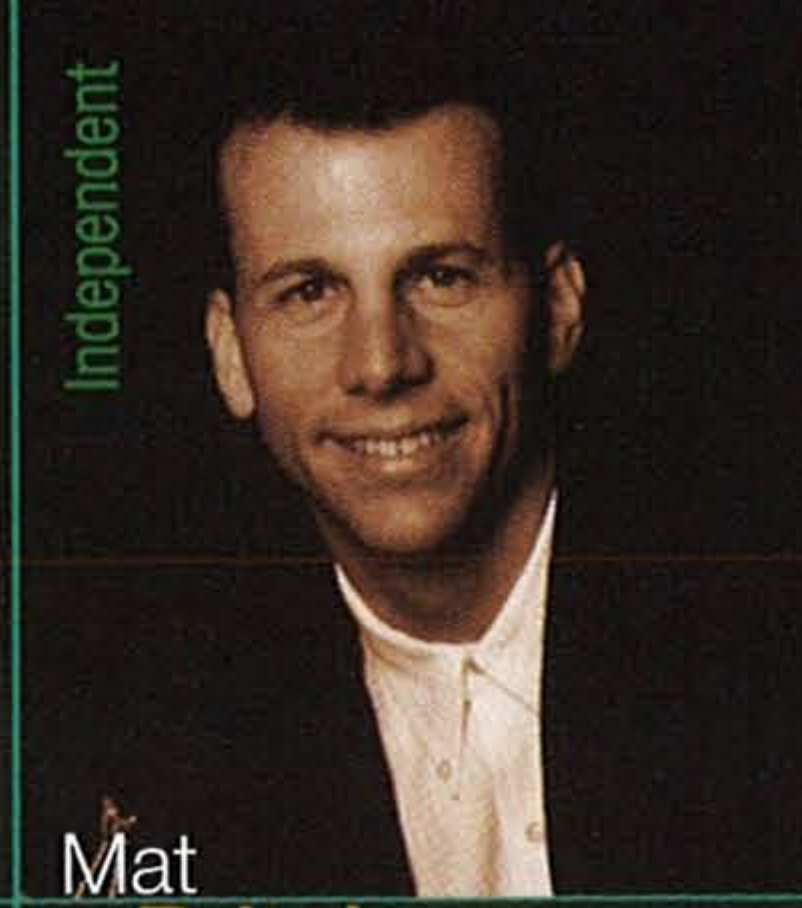

Independent

Mat Britain

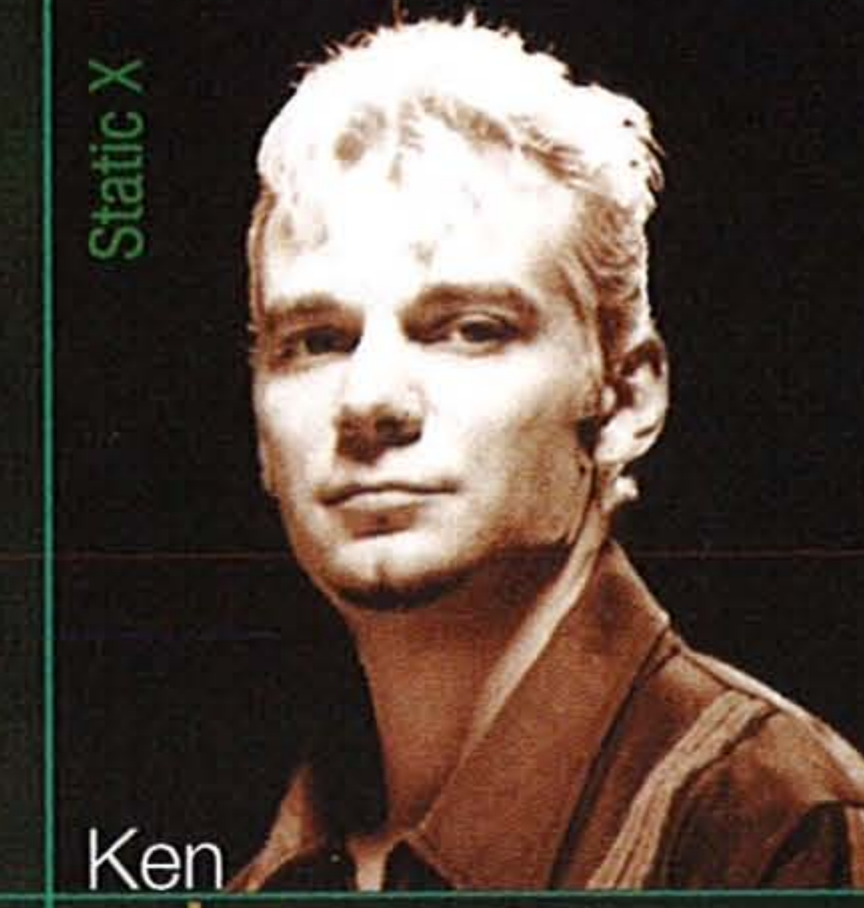

Static X

Ken Jay

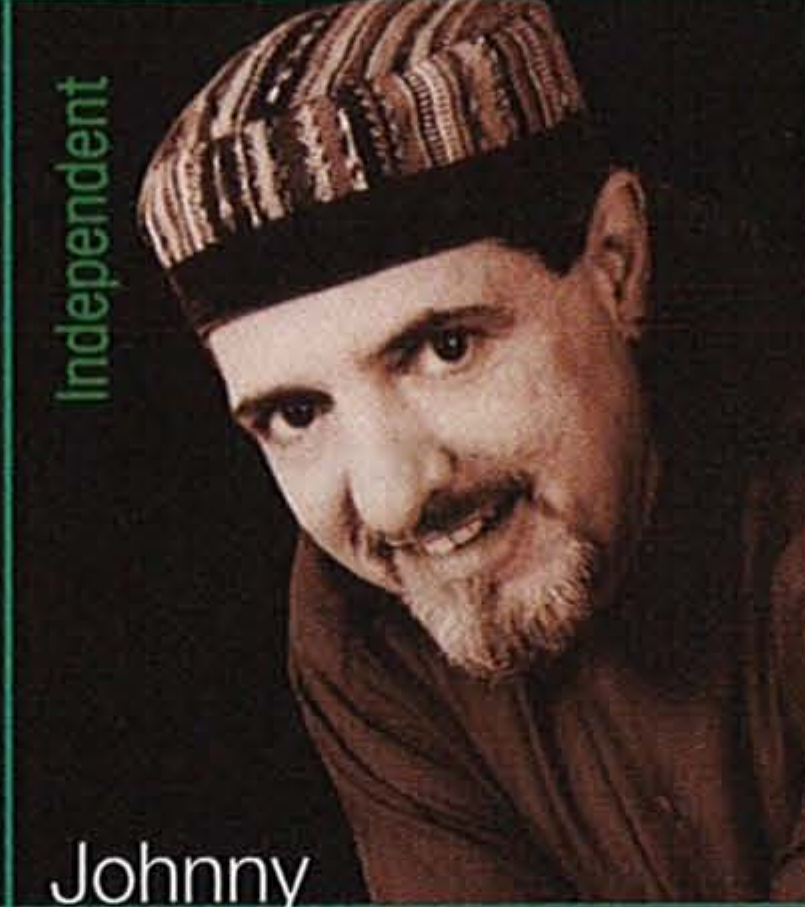

Independent

Johnny Conga

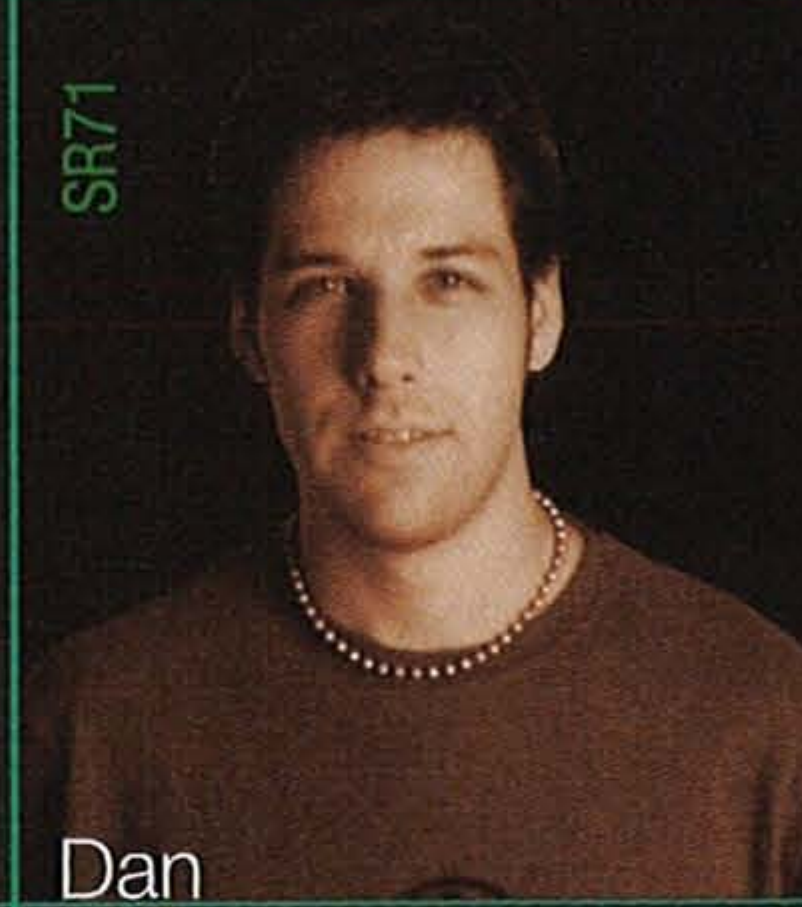

SR71

Dan Garvin

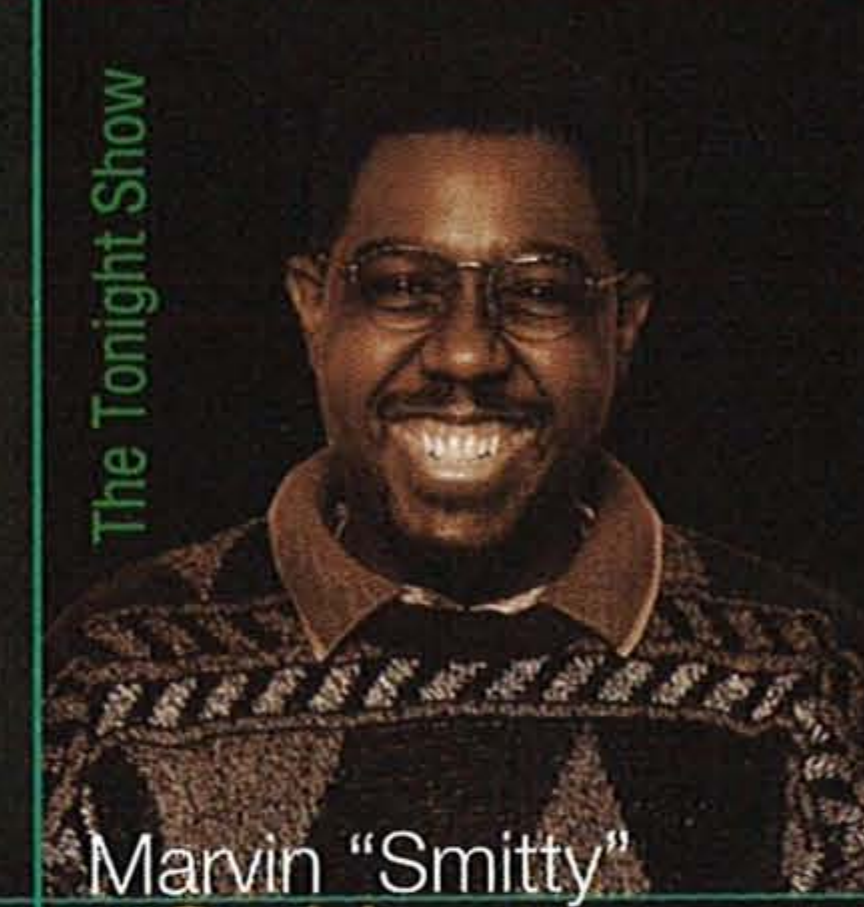

The Tonight Show

Marvin "Smitty" Smith

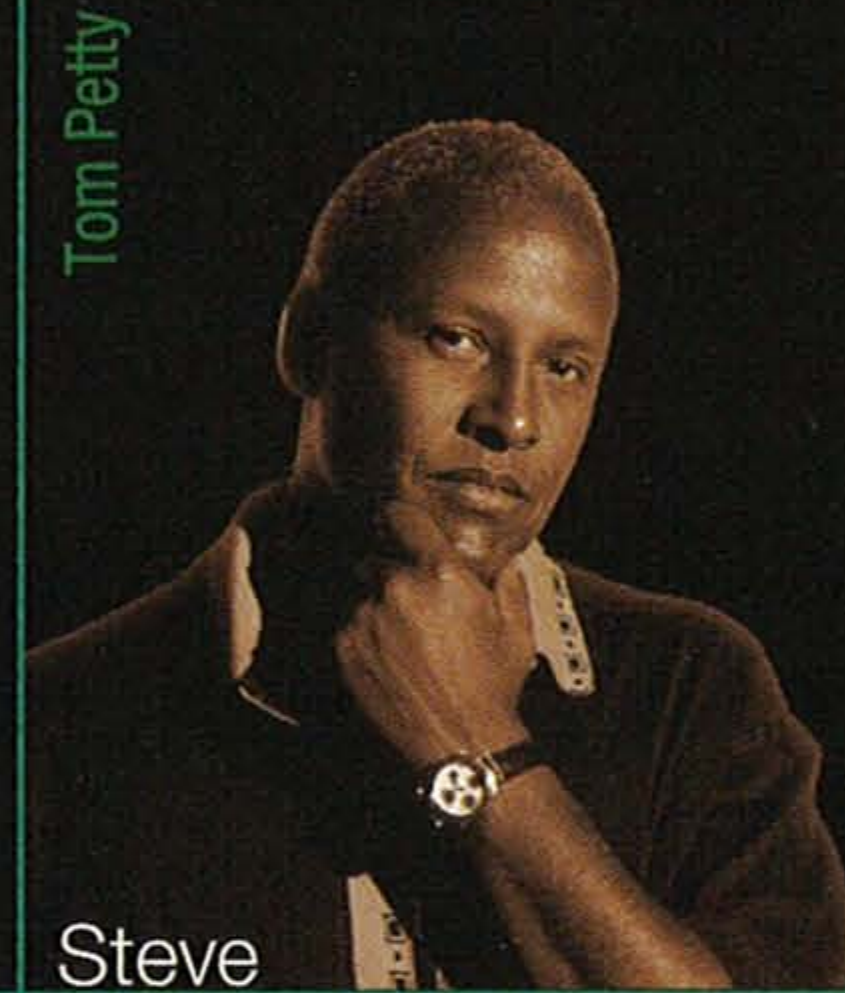

Tom Petty

Steve Ferrone



Niles Fisher



Eddie Conard

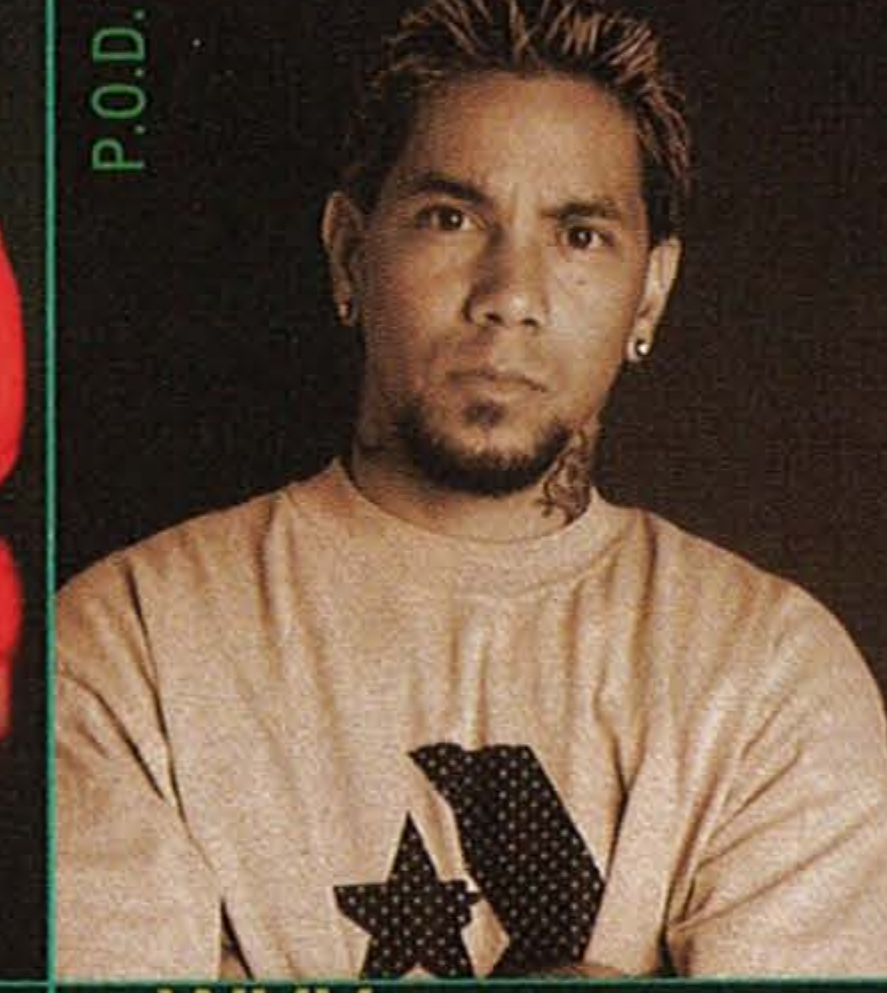

P.O.D.

WUV

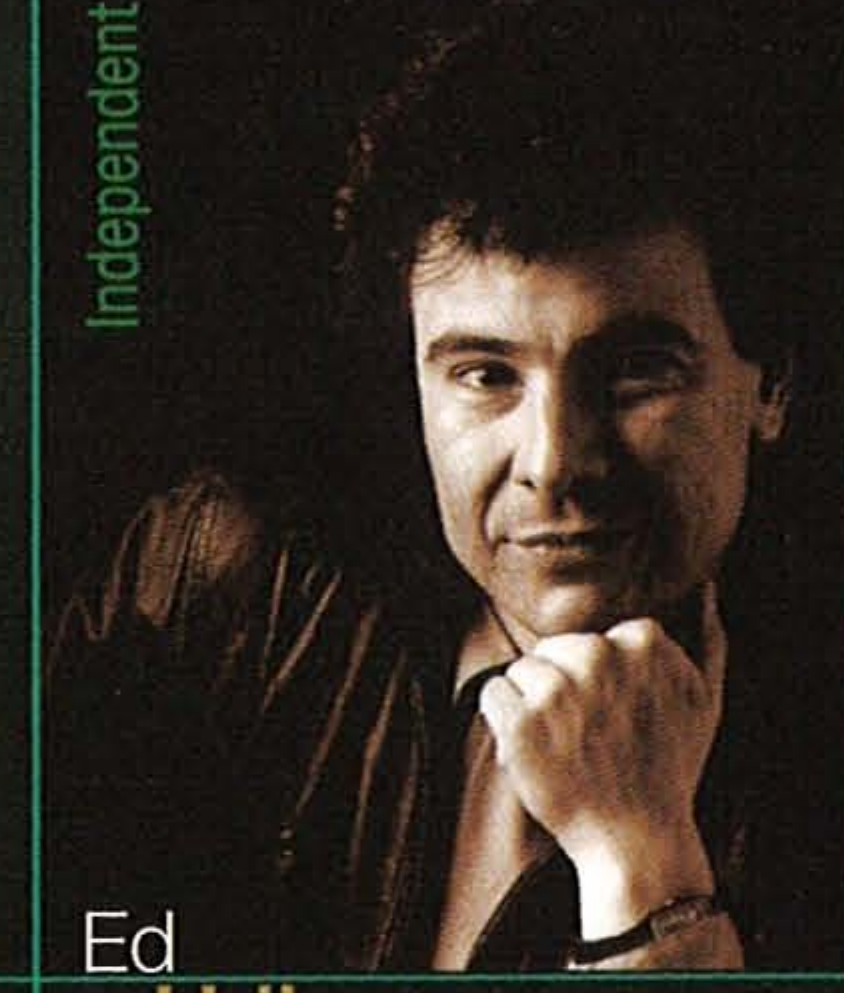

Independent

Ed Uribe

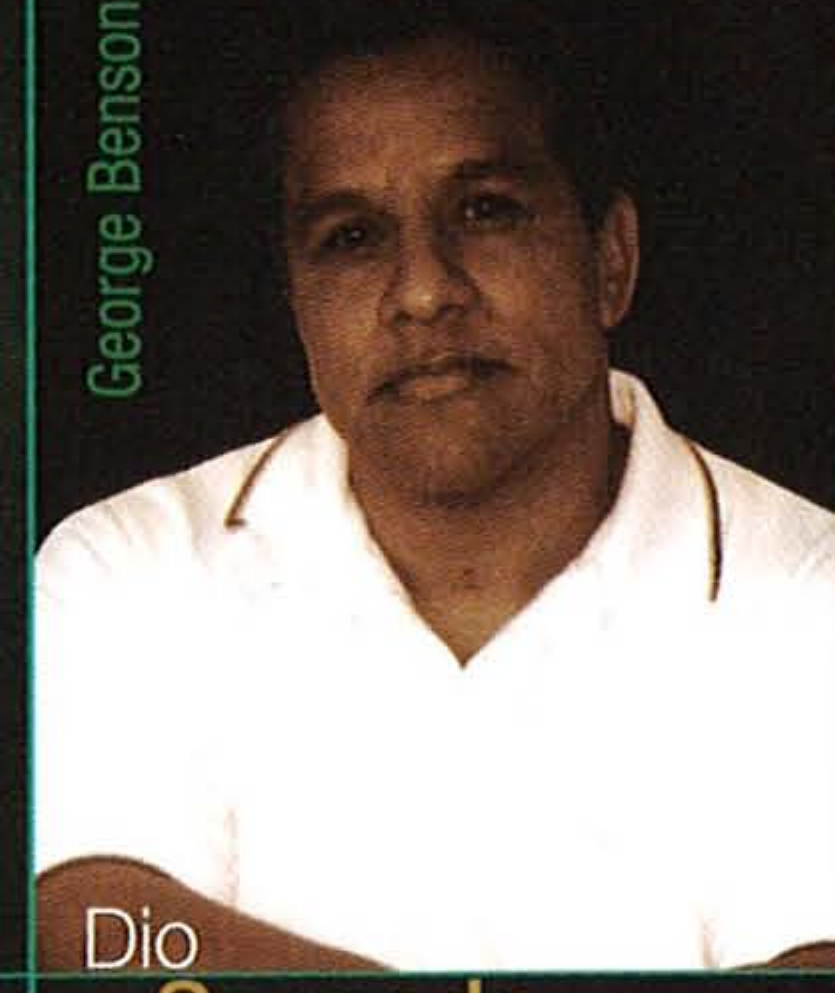

George Benson

Dio Saucedo



Richie Flores
Tropi-Jazz All Stars

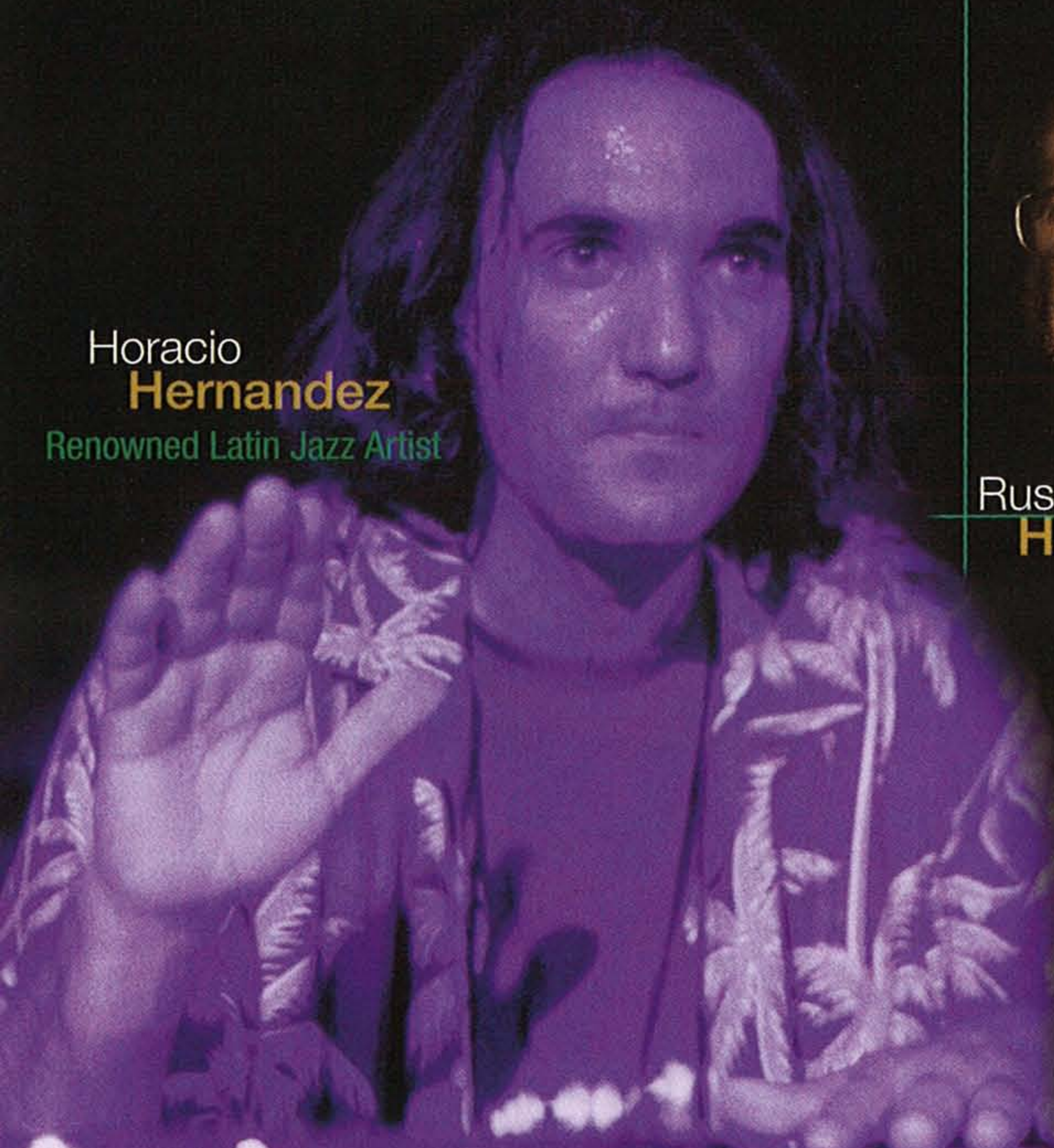

Horacio Hernandez
Renowned Latin Jazz Artist

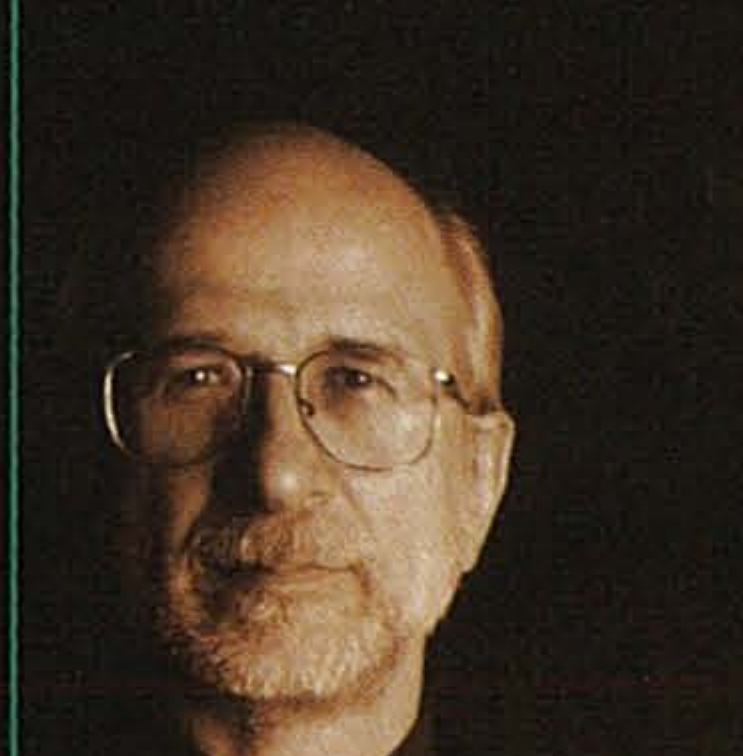

Russell Hartenberger



Bill Cahn

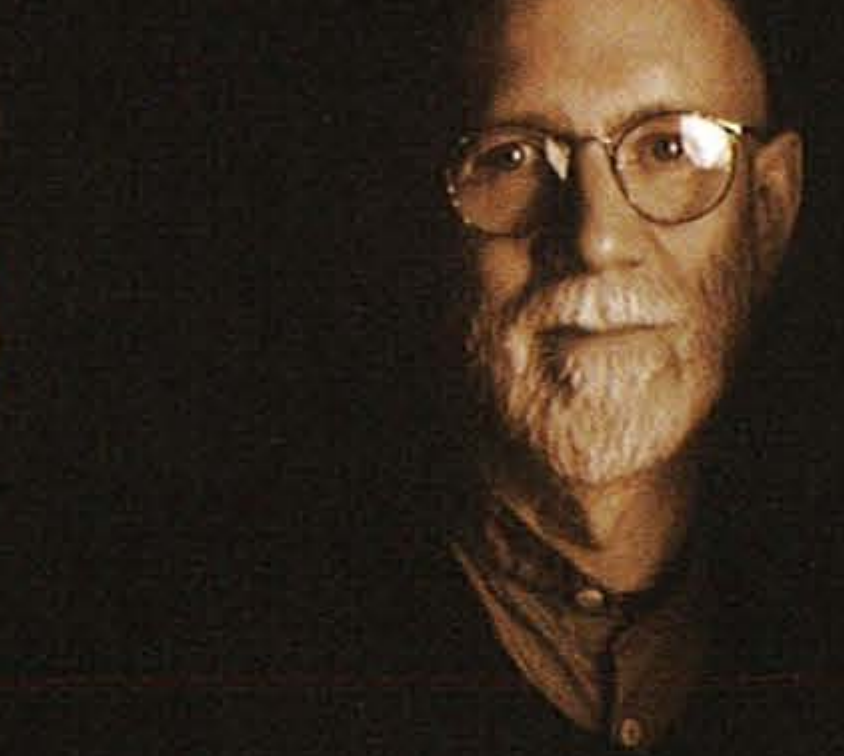

John Wyre



Bob Becker



Robin Engelman

Nexus



Nashville Studio

Glen Caruba

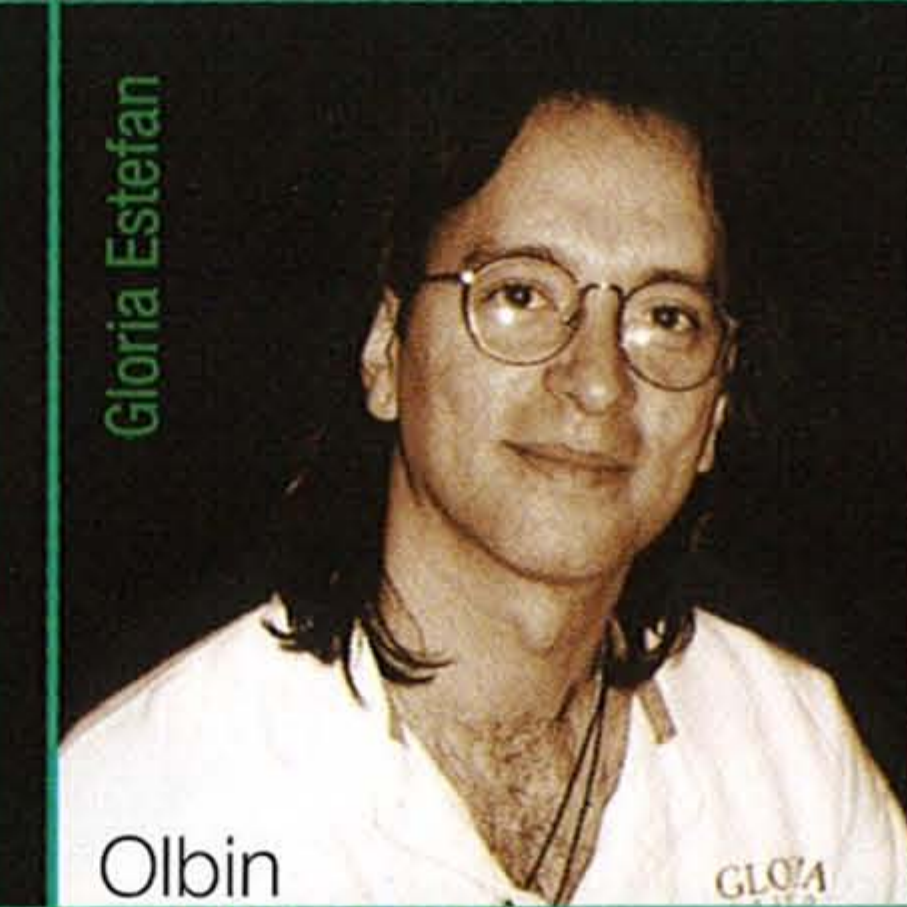

Gloria Estefan

Olbin Burgos

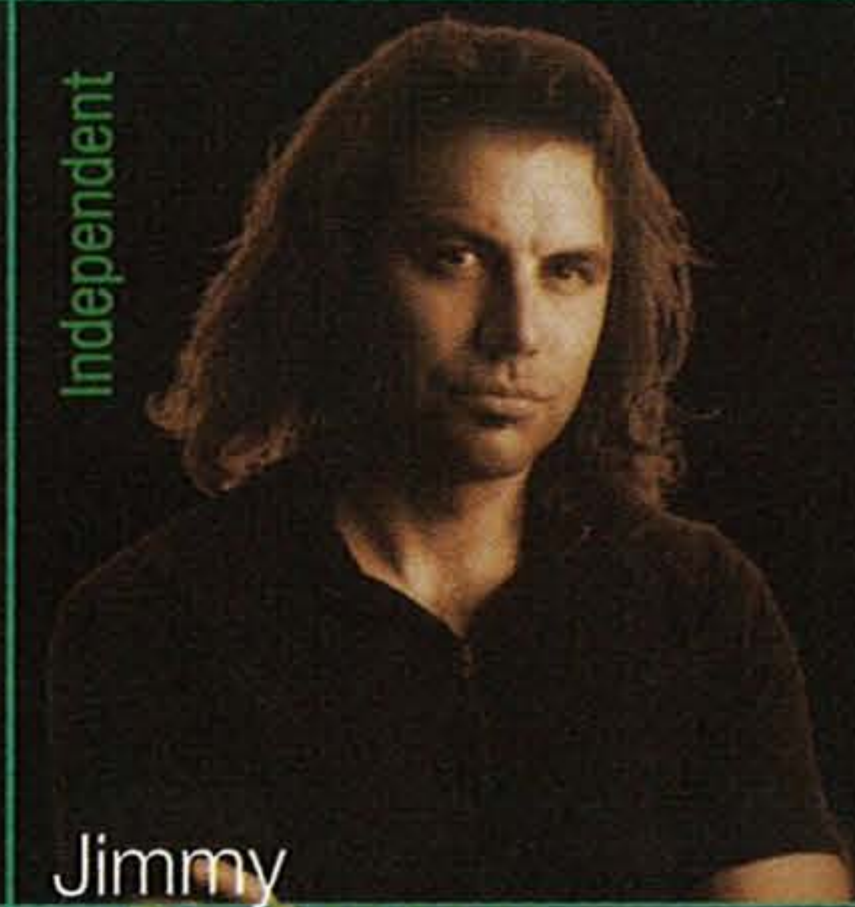

Independent

Jimmy DeGrasso

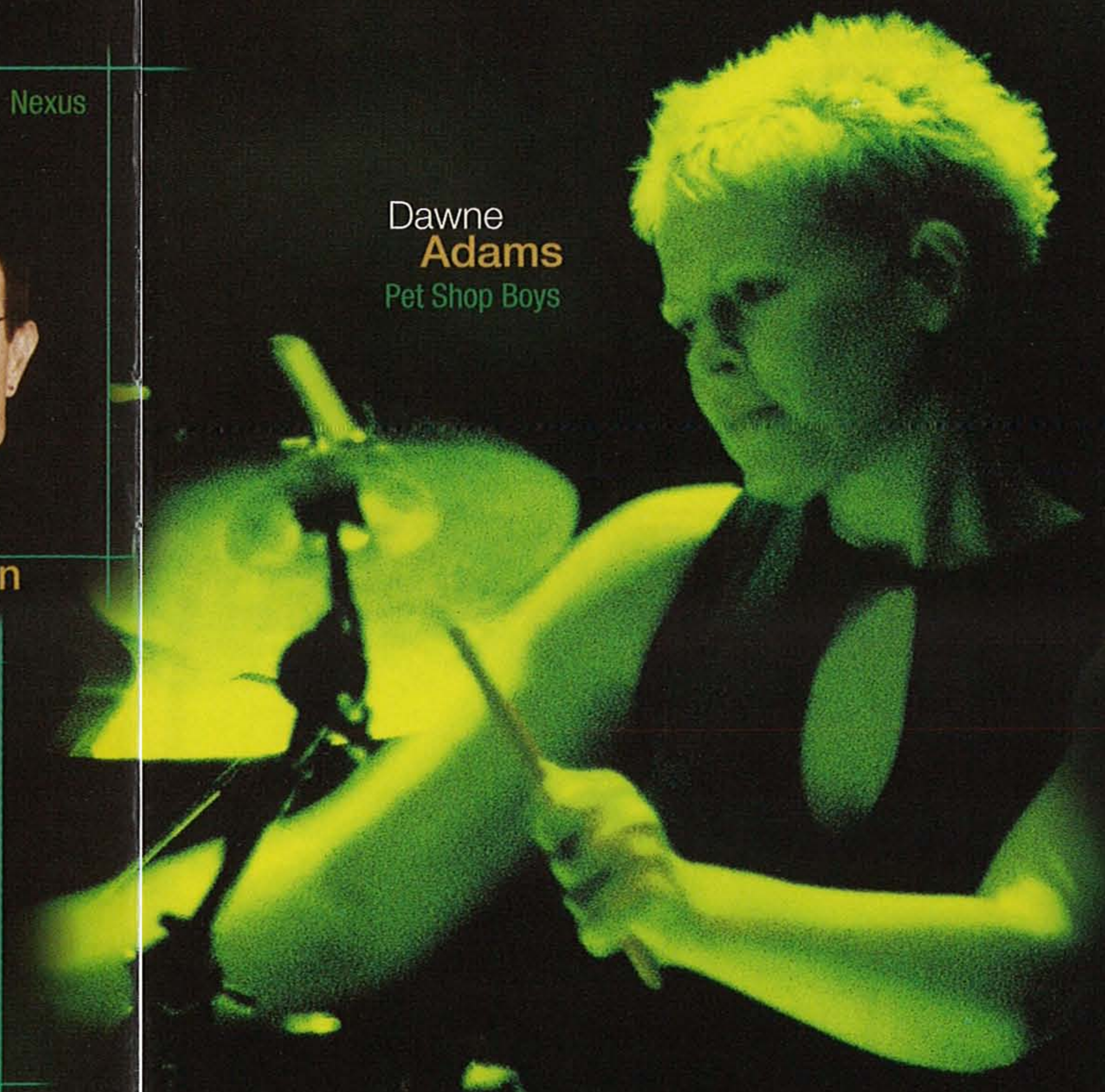

Dawne Adams
Pet Shop Boys

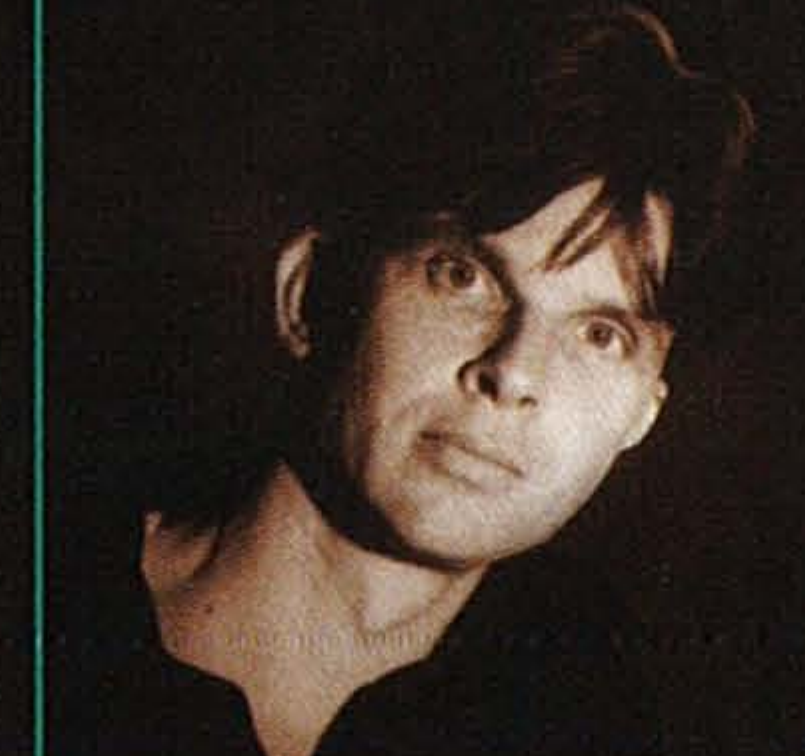

Bart Fermie

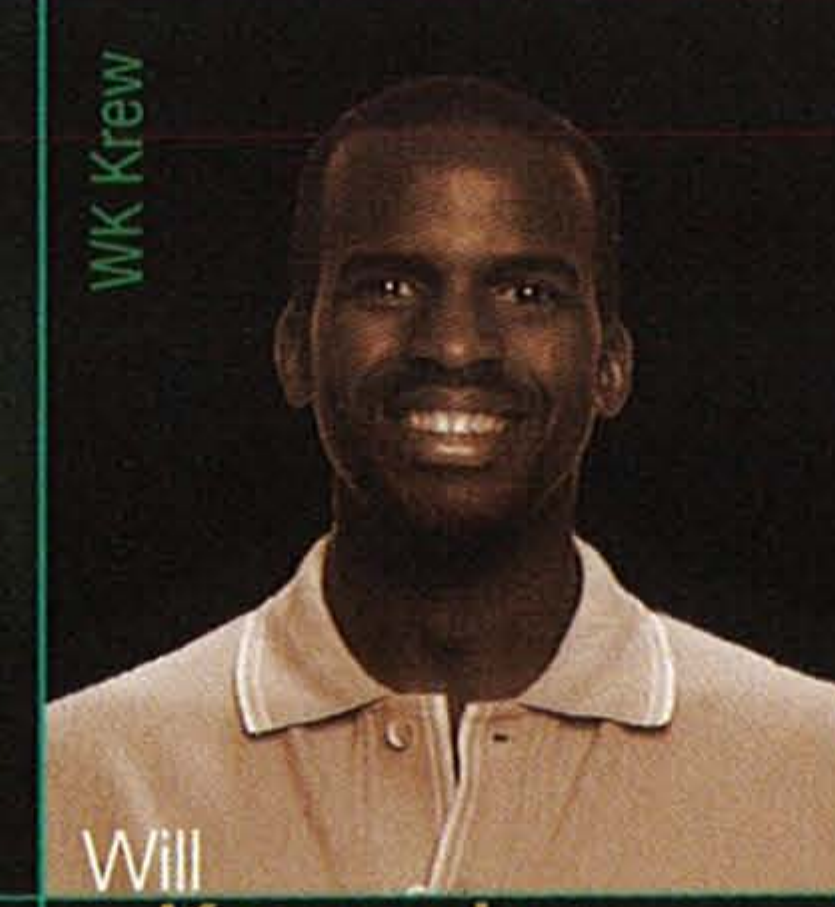

IWK Krew

Will Kennedy

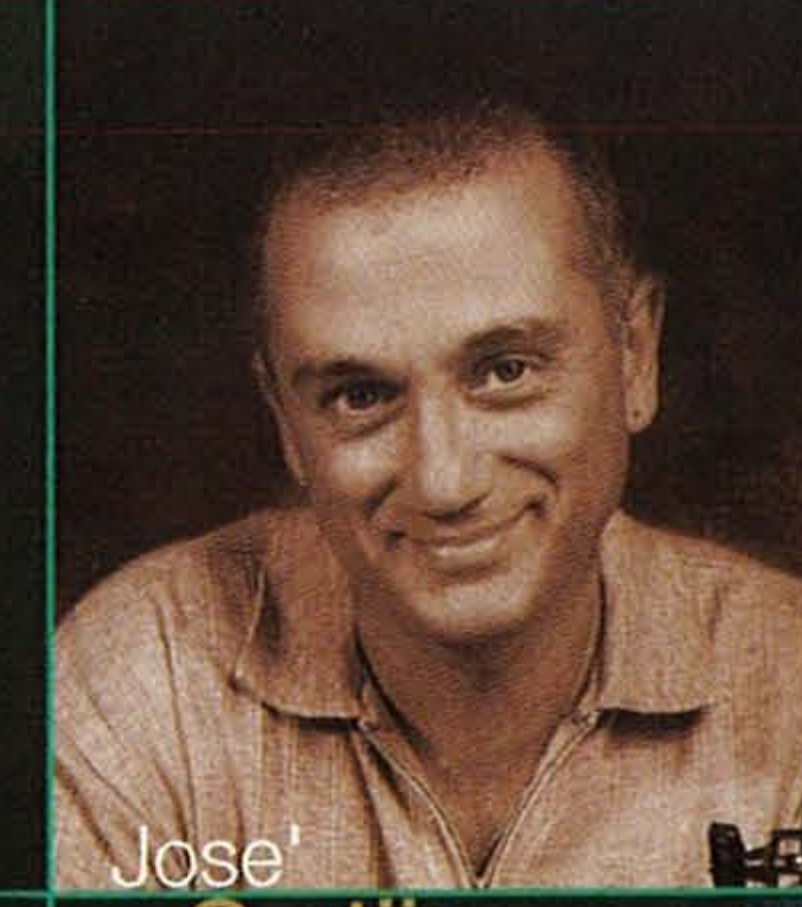

Jose Cortijo

Congas

Elite Wood Congas

Some of the top players in the world perform using our Elite Wood Congas as their live and studio instruments of choice. These Congas represent top of the line in every respect. Beautifully hand crafted shells of 100% aged Thai Oak and genuine Water Buffalo Heads help our Elite Wood Congas produce a tone steeped in tradition, and second to none. Their sound is extremely warm, sweet, and well rounded, with a perfect balance of both high and low end tones. The shell's exterior features a highly polished, durable finish in your choice of four beautiful see-through colors. Our polished solid steel Contour Crown Rims take the pain out of extended playing by providing a smooth, comfortable, contoured edge. Solid steel tension hooks and hardware plates with self-centering sleeves, keep the lugs centered and bind free at all times. This ensures the tuning process will be smooth, accurate and trouble free, time and time again. Our Elite Wood Congas are available in three sizes, 11", 11-3/4", and 12-1/2", but available with just one sound...awesome.



PCW-125DX 12-1/2" Elite Series Wood Tumba
PCW-110DX 11" Elite Series Wood Quinto
PCW-117DX 11-3/4" Elite Series Wood Conga

- #516 Tropical Blue
- #520 Raspberry Fizz
- #511 Natural
- #517 Island Shadow

Elite Fiberglass Congas

Elite Series Fiberglass Congas offer a precision formed fiberglass shell, uniquely shaped to provide a brighter tone, with increased volume, great projection, and excellent hi-end cut. Their sound is well balanced, full and rich, perfectly at home in most any playing situation. These drums have become some of the most popular instruments we offer due to the extra volume available to the player in live performance settings. Our Elite Series Fiberglass Congas also share all of the outstanding features of our Elite Wood Congas. Features like fully aged supreme quality Water Buffalo Heads for great response and tonal quality, and polished solid steel Contour Crown Rims, perfect for today's aggressive playing styles. High strength polished steel Tension Rods and hardware with a built in self centering sleeve help insure the claw stays perfectly centered during tuning for the ultimate in precision and extended durability. Elite Fiberglass Congas are available in three sizes, 11" Quinto, 11-3/4" Conga, and 12-1/2" Tumba, and are offered in both high gloss #602 Bistre Black as shown below or #607 Deep Orchid shown at left.



PCF-117DX 11-3/4" Elite Series Fiberglass Conga
PCF-110DX 11" Elite Series Fiberglass Quinto
PCF-125DX 12-1/2" Elite Series Fiberglass Tumba

- #602 Bistre Black
- #607 Deep Orchid



Conga Bag
PPB-100
Protect your Conga investment with one of our heavy weight nylon Conga Bags. One size fits all of our various Conga sizes including all Fiberglass and Primero Models.

Bongos

Elite Wood Bongos

Pearl Elite Series Wood bongos offer a beautiful, warm, traditional bongo tone, combined with the quality that only Pearl can provide. Our Elite Wood Bongos represent the ultimate Bongo in both sound and performance. Great features like an oversized Hembra for maximum bass response, prime Thai Oak shell for a warm, smooth tone, and polished heavy duty steel hardware for durability and tuning integrity, make our Elite Series an excellent choice for both the pro player and hobbyist alike. Our Contour Crown rims provide painless playability, and four beautiful color choices, including new Island Shadow shown here, insures they look as good as they sound.



- #516 Tropical Blue
- #520 Raspberry Fizz
- #511 Natural
- #517 Island Shadow

PBW-300DX
7" and 9" Elite Wood Bongos

Elite Fiberglass Bongos

For players seeking greater volume and projection, Pearl's Elite Series Fiberglass bongos have the answer. Fiberglass has long been a favorite of performing professionals due to the brightness and volume of the tone, and Pearl's Elite Series Fiberglass Bongos have the sound, features, and quality that put them way ahead of the pack. Our Elite Series Fiberglass Bongos share the same outstanding polished hardware and Contour Crowns and are available in Bistre Black and Deep Orchid as shown here to perfectly match our Elite Fiberglass Congas and Djembes.



- #602 Bistre Black
- #607 Deep Orchid

PBF-300DX
7" and 9" Elite Fiberglass Bongos

Timbales

Elite Timbales

Pearl Elite Timbales offer an exclusive, 7.5", extra deep, premium manufactured Brass Shell, with precision rolled bearing edges for an unbelievable tone that features exceptional warmth, cut and excellent cascara. Brass offers the warmth of wood, combined with the volume, projection and presence of metal, to create what many call the perfect Timbale voice. These incredible Timbales are perfect for the needs of the professional player, or any player that requires an uncompromising, authentic Timbale sound. Elite Timbales feature durable powder coated traditional steel hardware, lugs, and rims, and extra long reach, self centering tension nuts. This allows perfect rimshots and offers the ultimate in both tuning integrity and dependability. Elite Timbales are sold individually so you can select exactly the size combination that you desire. And for a truly winning combination, Pearl's QRS Multi-stand allows for quick mounting with endless positioning capabilities and the ability to add accessories like never before.



ETB-13 13" Brass Shell Timbale
ETB-14 14" Brass Shell Timbale
ETB-15 15" Brass Shell Timbale

Djembes

Elite Wood Djembes

Our Elite Wood djembe is perfect for both the professional player as well as the occasional drum circle enthusiast. Djembes are well known for their versatility, offering great highs, a rich full bodied tone and beautiful low end presence. With origins from western Africa, Djembes have become extremely popular today, showing up in all types of musical performances, from unplugged acoustic shows at local clubs, to stadium tours with some of the biggest names in music today. Our Elite Wood Djembe shell is pure 100% aged Thai Oak, featuring a smooth hourglass shape for a warm traditional tone exclusive to this instrument. Thinner, ultimate quality, true Goat Skin Heads help our Elite Wood Djembe to produce an extremely wide frequency response, allowing the drum to be the most versatile of all hand drums. Our polished steel Contour Crown Rims take the pain out of playing by offering a smooth edge, and our solid steel claws and hardware provide great tuning integrity. Our 12.5" Elite Wood Djembe is available in a choice of four lustrous colors shown below, and comes complete with carry strap.



PJW-340
12.5" Thai Oak Djembe with Strap.

- #516 Tropical Blue
- #520 Raspberry Fizz
- #511 Natural
- #517 Island Shadow

Elite Fiberglass Djembes

For players looking for a Djembe with more volume and brightness, without loosing the versatility and great tone these instruments offer, look no further than our Elite Fiberglass Djembes. Their precision, hand formed fiberglass shells with specially contoured shape, and genuine goat skin heads provide the widest dynamic range possible. Their tone offers rich low end, and their unique suspension-type center ring and polished steel Contour Crown hoop produces unmatched sustain. Elite Fiberglass Djembes are available in two sizes, 12.5" and 14", and two color choices, complete with carry strap.



PJF-320
12.5" Elite Fiberglass Djembe with Strap.



PJF-350
14" Elite Fiberglass Djembe with Strap.

- #602 Bistre Black
- #607 Deep Orchid

Cajons

Elite Tube Cajons

Elite Series Tube Cajons are an extremely exciting all new Pearl exclusive. These 28" tall, 100% S class Thai Oak tubes feature a thin oak playing surface instead of a traditional animal skin head. They are played like Congas, using all the same techniques, but their tonal quality is much different. Elite Series Tube Cajons offer an incredibly warm and resonant tone, with great bass response and cutting hi-end slaps. They are pre-tuned with no adjustment necessary. No other instrument sounds like a Tube Cajon, with many new artists finding them their instrument of choice. They are extremely versatile as a stand alone instrument and offer a perfect addition to any player's percussion set-up. Three sizes are available, 10", 12" and 14". Our Tube Cajons are also a dream come true when it comes time to transport your gear to a gig. All three size drums neatly nest inside one another, allowing three instruments to take up the space of only one during transport.



For compact travel our Elite Series Tube Cajons nest to allow three drums to take up the space of one.

PCJ-024 10", 12", 14" Set with Bag
PCJ-1012 10" & 12" Set
PCJ-1214 12" & 14" Set



PCJ-120 12" Elite Series Tube Cajon
PCJ-100 10" Elite Series Tube Cajon
PCJ-140 14" Elite Series Tube Cajon

Batas

Elite Wood Batas

Our double headed Batas are based upon ancient African designs and feature naturally finished 100% Thai Oak shells for great tone. Chrome plated conga style tuning brackets with extra strength claws and traditional rims, provide excellent tuning features. These prized ceremonial drums offer a great, warm, traditional tone. The smaller head of the Bata sounds similar to a Bongo, while the larger head has a Djembe type sound. Both drums are played together to create endless rhythmic patterns. Elite Batas are available in 3 sizes.



PBA-50 Oconcolo (small) Elite Bata
PBA-60 Itotele (medium) Elite Bata
PBA-70 Iya (large) Elite Bata

Elite Box Cajons

Pearl's all new Elite Series Box Cajon represents an entirely new concept for Box Cajons. We have taken a traditional Spanish style design and incorporated four tunable strings inside the drum which rest against the playing surface. This adds a great new depth and presence to the overall sound never before available with existing Box Cajons. The instrument is played while seated on the top of the box facing forward. The top right and left corners of the face plate are played with the Pearl logo designating the striking location for maximum bass response. The rear sound hole mixes the internal sound with the attack of the face plate. Our individually tunable strings act as snares across the face plate offering a wide variety of tone response. Pearl Elite Series Box Cajons are constructed of 100% Thai Oak with triangle bracing around the sound hole for strength and durability. The thin playing surface or face plate is bonded at the bottom and lower sides and screwed in place along the top to allow the compression edges to be adjusted for optimum sound. Elite Series Box Cajons are available only in #511, High Gloss Natural Oak.



PBC-511
Elite Series Box Cajon

The rear of the Elite Series Box Cajon features a sound hole to mix the internal sound of the drum with the attack of the striking surface.

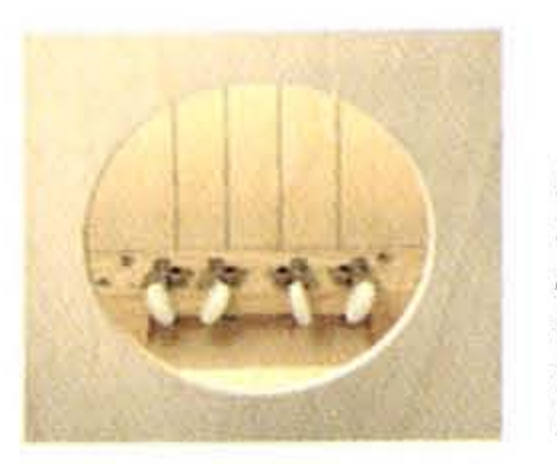

Four individually tunable strings act as snares adding a new dynamic to the overall sound of a traditional Spanish style Box cajon.

Congas

Primero Wood Congas

Our extremely popular, naturally finished Wood Primero Conga set is the perfect blend of cutting edge, high quality features, combined with outstanding value for the working percussionist. Primero Wood Conga sets offer a full size 10" and 11" Conga, featuring pure 100% Thai Oak construction for an extremely warm, rich tone, and come complete with a fully adjustable, sturdy, double braced twin conga stand. Black powder coated steel Contour Crown rims and high quality Water Buffalo heads, give these Congas the look and sound of Congas costing hundreds more. Primero Congas are available in #511 High Gloss Natural Oak.



PWC-201
10"/11" Thai Oak Conga Set with Stand.

PWC-201S
10"/11" Thai Oak Conga Set with Basket Stands. (Not Shown)

#602 Bistre Black
#610 Deco Blue

PFC-201
10"/11" Fiberglass Conga Set with Stand.

PFC-201S
10"/11" Thai Oak Conga Set with Basket Stands. (Not Shown)

Djembes

Primero Fiberglass Djembes

Our 9.5" Primero Fiberglass Djembe is the perfect portable drum for the weekend drum circle crowd. Djembes are more forgiving than any other hand percussion instrument allowing even the beginning percussionist to get great tone and playing enjoyment as they learn. Our Primero Fiberglass Djembe is an excellent hand drum featuring a precision laid fiberglass shell specifically designed to focus and transfer the energy generated by the head. Other features include black powder coated Contour Crown Rim, solid steel tension rods and genuine Goat skin head. Our Primero Fiberglass Djembe is available in two gel coat colors, and comes complete with carry strap.



PJF-310
9.5" Primero Fiberglass Djembe with Strap.

#602 Bistre Black
#610 Deco Blue

Mini's

Primero Mini Percussion

Pearl Percussion Mini's are miniature versions of our Primero Djembe, Conga and Bongos. Constructed from durable gel-coated Fiberglass and finished in 3 vibrant colors. Fully tunable and highly transportable. They're perfect for intimate gigs, picnics or for the young player who requires a manageable size while getting started in the exciting world of Hand Percussion.



PMD-1 #610

PMC-1 #603

PMB-1 #608

Primero Fiberglass Congas

If you need extra volume, cut, and projection from your Conga set, Primero Fiberglass is the only choice. Primero Fiberglass Twin Conga sets feature a 10" and 11" matched set of Congas with precision formed, supreme quality fiberglass shells. Powder coated black steel Contour Crown rims, genuine Water Buffalo heads, and sturdy, double braced twin Conga stand complete the package. For performance, sound, and price, you simply cannot find a better set of Congas.

Bongos

Primero Wood Bongos

Primero Bongos are based upon our top of the line Elite Series and they offer many of the same outstanding features as Bongos costing much, much more. Their 100% Thai Oak construction, proportional sized drums, and high quality heads, combine to produce a tone that is very warm and resonant with great response. Black powder coated Contour Crown rims and high strength steel tension rods ensure accurate tuning and dependability under any playing conditions. Primero Bongos are available in #511 High Gloss Natural Oak.



PWB-100 7"/8.5" Thai Oak Bongos.

Primero Fiberglass Bongos

Primero Fiberglass Bongos provide many of the same great features of our Elite Series Bongos. Couple this with added affordability and you have a winning combination of high quality and value. These Bongos also feature our Black powder coated Contour Crown rims and traditional Water Buffalo heads. Tuning is consistent and reliable thanks to high strength steel tension rods. A durable high luster gel coating insures years of service and great looks.



PFB-100 6"/7" Fiberglass Bongos.

#602 Bistre Black
#610 Deco Blue



PTF-5134
13"x14" fiberglass Shell Timbales/tilting stand

PTS-5134
13"x14" Steel Shell Timbales/tilting stand

#602 Bistre Black
#610 Deco Blue

Cowbells

Bala Cowbells

The All New Bala Cowbells from Pearl Percussion offer the professional percussionist a modern instrument that effortlessly exudes room penetrating energy with maximum resonance. From the first strike you will notice the pure, undiluted tone of a quality instrument, This sonic power is achieved via a synergy of metal alloys that sets Bala Cowbells apart from the rest. Not only are Bala Cowbells sonically appealing but also visually, with a smooth, virtually seamless design with a lustrous polished finish. Bala Cowbells are available as a mounted model or a classic hand-held. If you're looking for that traditional Salsa "Campana" sound or simply expanding your drumkit, look no further than Bala Cowbells.

Elite Series

Our Elite Series True Tone Cowbells feature advanced, sonic engineered shapes, with precision Argon welded seams, to produce a sound quality you've just got to hear to believe. Their tone is full, clear and bright, with excellent sustain. Their angled mounting bracket features an internal eyebolt that clamps against the mounting arm creating the most secure, easy to use mounting method available. Elite Cowbells are available in six sizes, including our Rock Bell, which features our exclusive PowerFlange edge formed into the bell. PowerFlange is a ridge at the opening of the bell that allows it to produce a dry, controlled, yet open tone with more volume and strength than bells with plastic strips attached. With PowerFlange, you'll never have to muffle your bell again to get that great Rock Cowbell sound.

Our Elite Series hand-held Agogo bell is an excellent performance bell. It offers an authentic Brazilian sound and tuning. You can play the Agogo bell traditionally with sticks, and you can also squeeze the flexible connecting handle to click the two bells together for an additional sound. The ECB-23 has all the same great features but in a mountable version.

Primero Series

If you're looking for both quality and excellent value, you will not find a better bell for your money than our Primero Series Cowbells. Great tone, superb volume, fully precision welded seams, and a sturdy mounting system make these bells a great addition to any percussion set-up. Primero bells are available in 4" and 6" sizes.

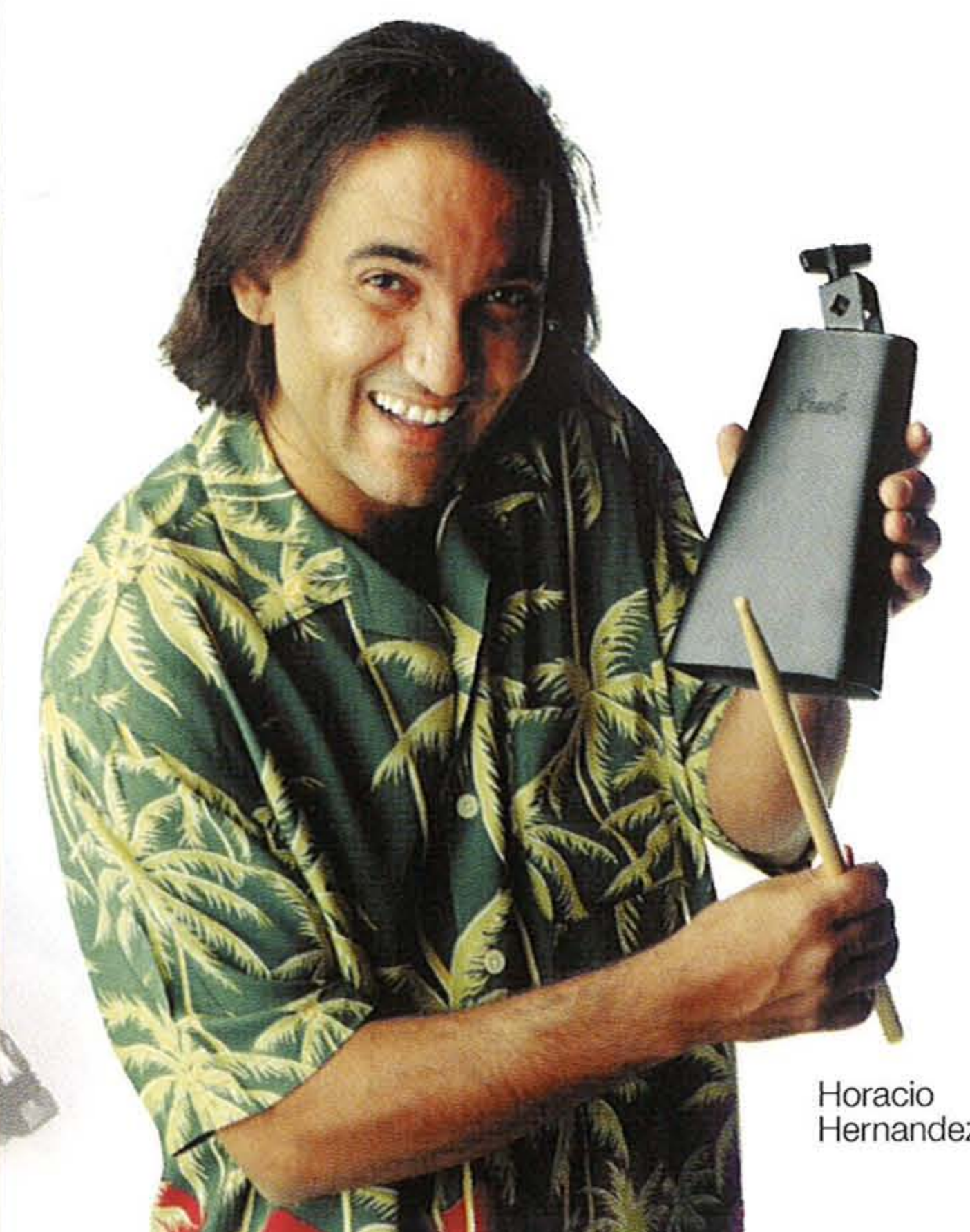

Horacio Hernandez



ECB-10 Rock Bell

ECB-9 Timbale Bell

ECB-6 Mambo Bell

ECB-5 Fusion Bell

ECB-3 Cha-Cha Bell

ECB-1 Chico Bell

PCB-6 Primero Bell

ECB-23 Mounted Agogo Bell

PCB-4 Primero Bell

ECB-22 Agogo Bell

BCM-10 Mounted Campana Bell

BCH-10 Hand-Held Campana Bell

Archie Pena

Timbales

Primero Timbales

Primero Timbales feature a precision formed smooth Chrome Plated Steel Shell offering a tone that is slightly drier than Brass, with great volume, projection and attack. The smooth continuous look of the shell is very reminiscent of traditionally made Timbales and is perfect for complicated cascara patterns and shell sticking. To compliment the look of the shell, drumset style lugs, tension rods and solid steel hoops are used to provide excellent tunability. Our Primero Timbale set features a 13" and 14" steel Timbale, and a sturdy Timbale stand featuring full height and tilt adjustments, dual drum bumpers, and a cowbell holder. A Pearl 5" cowbell and a pair of Timbale sticks are also included.

Flat Timbs

Primero Flat Timbs

Primero Flat Timbs are a great way to integrate percussion sounds into your drum kit set-up, or they can be used in a traditional percussion set-up to provide a much wider range of Timbale voices. Primero Flat Timbs are 3"x13", and are available with either Brass or Steel shells. They feature drumset style rims and lugs, and come complete with Pearl's patented Integrated Suspension System Mount.



PTB-313I
3"x13" Brass Shell Timb



PTE-313I
3"x13" Steel Shell Timb



Archie Pena

Shakers and Effects

Hand Held Percussion

We offer a full line of innovative hand percussion effects to help you create a wide variety of interesting and beautiful sounds and rhythms. Our Fiberglass Shekere is an outstanding instrument featuring a precision formed, traditional shaped, fiberglass shell for increased volume and projection. It is about half the weight of traditional Shekeres and has adjustable tension beads allowing you to vary the sound. Our new Egg Carton features three egg shakers in a translucent tube. The eggs can be played separately or all packed in the carton as a complete unit and played. Our new hi and low Agogo Pops are Agogo bells with an internal weighted striker that can be played like a shaker, gripped by the foam handle, or held and hit with a stick. Pearl aluminum Hex Ganzas are uniquely shaped shakers that produce three separate sounds by simply shaking them against different sides of the instrument. Their unique light tone can also produce a wah-wah effect.

The Shakerine, Mini Shakerine and Mini-Ganzeiro combine a shaker/ganza type sound with a Tambourine jingle sound. Both sounds can be played independently or together by varying the technique. The Shakerine features a full size wooden Tambourine with a Ganza handle. The Mini-Shakerine is a small square Ganza with a set of Tambourine jingles and the Mini-Ganzeiro is larger with drier Brazilian style jingles. Our new Ago-Shas are a combination of a Ganza and Agogo with built in striker. They are available in hi and low tone sizes and a double featuring both attached to a single Ganza. Play the Ganza or the Agogo separately or both together to create a host of sounds. Our Beaded Maracas feature Shekere style beads, comfortable foam handles, and a durable fiberglass body for an excellent sound with greater control. Our Basket Ganza is a 4"x9" woven instrument with fiberglass ends. Wooden sticks inside create a light, airy sound when shaken against the sides or ends. And nothing creates an airy sound like Pearl's new Windchimes. A sweep of the hand fills the room with a transcendental wash of sound. These chimes provide a male and female connection on opposing ends allowing them to be attached or "stacked" in sets of two or even three. Available in your choice of Aluminum or Gold finish and includes a striker.

Unlike fragile traditional organic Guiros, Pearl's Fiber Guiro is light-weight yet extremely durable and provides optimal projection due to its fiberglass construction. And with an included striker and two different playing surfaces you have a world of sonic possibilities in your hand.

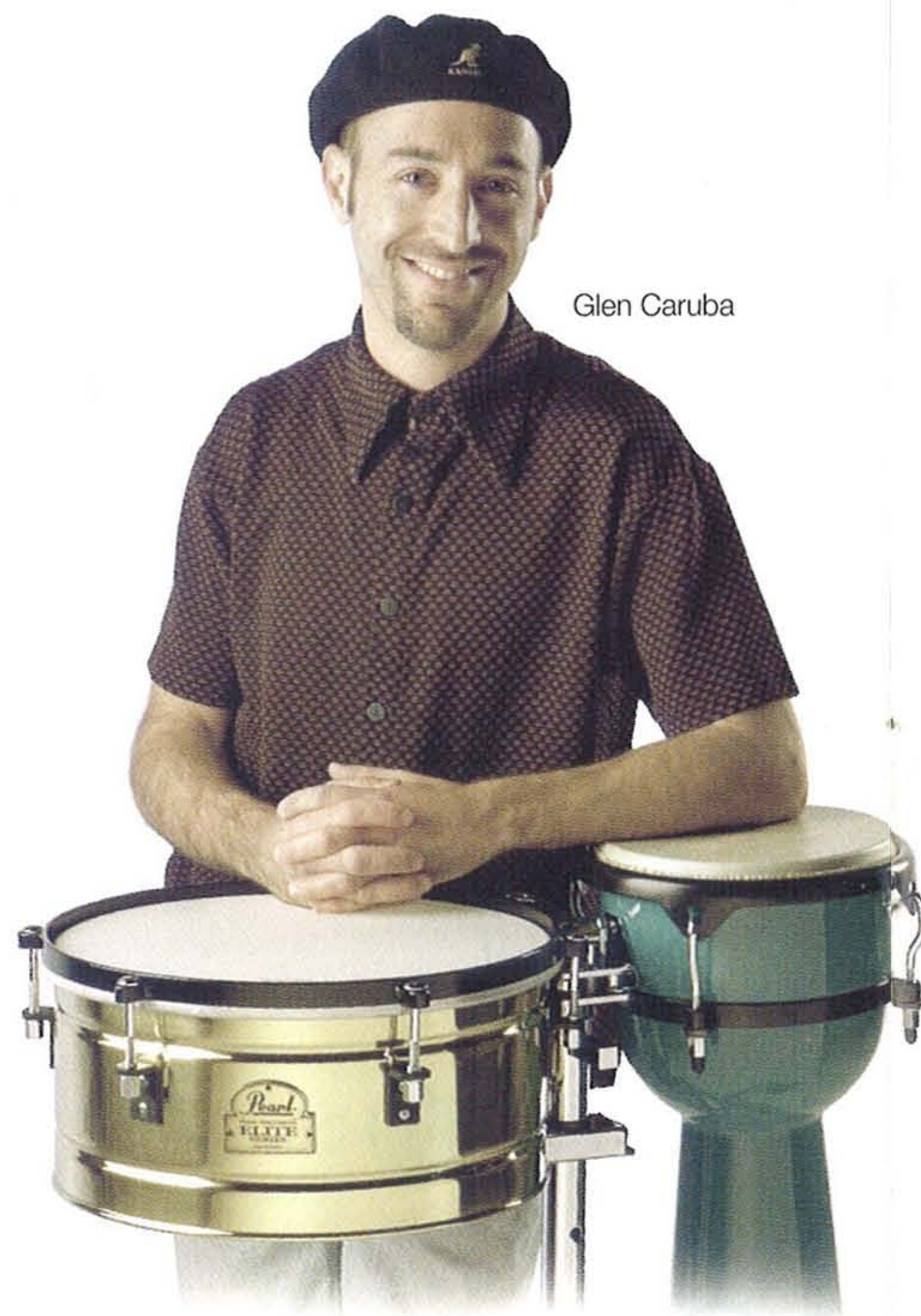

Glen Caruba



* Invented by Bart Femie

Stands

Quick Release System Multi-Stand

Pearl's all new QRS Multi-Stand represents the most exciting, most innovative hardware design in years, specifically for the percussionist of today. The Quick Release System allows easy, one handle mounting of a variety of different percussion instruments with no loose wingnuts, bolts or washers to ever keep up with again. You can mount practically any combination of instruments on the QRS stand and take full advantage of a multitude of adjustment possibilities which add up to the most sturdy, rock solid percussion stand on the market today. At the heart of the new QRS Multi-Stand is an all new spring loaded swing handle that offers one touch, secure clamping, for practically any instrument with an appropriate standard 2 hole mounting bracket. Specialty brackets are also available for attaching bongos and cowbells to turn the QRS Multi-Stand into the only stand you might ever need. The new QRS Multi-Stand offers complete height adjustability, 2 removable, fully adjustable drum supports mounted on its leg supports, and each leg of its ultra-sturdy leg tripod extends, allowing you to tilt the stand in any direction to achieve set-up possibilities never before available with traditional stands. Use the QRS Multi-Stand to mount your Congas, Timbales, Djembes, and Bongos in any combination imaginable. The all new QRS Multi-Stand is a percussionists dream come true.

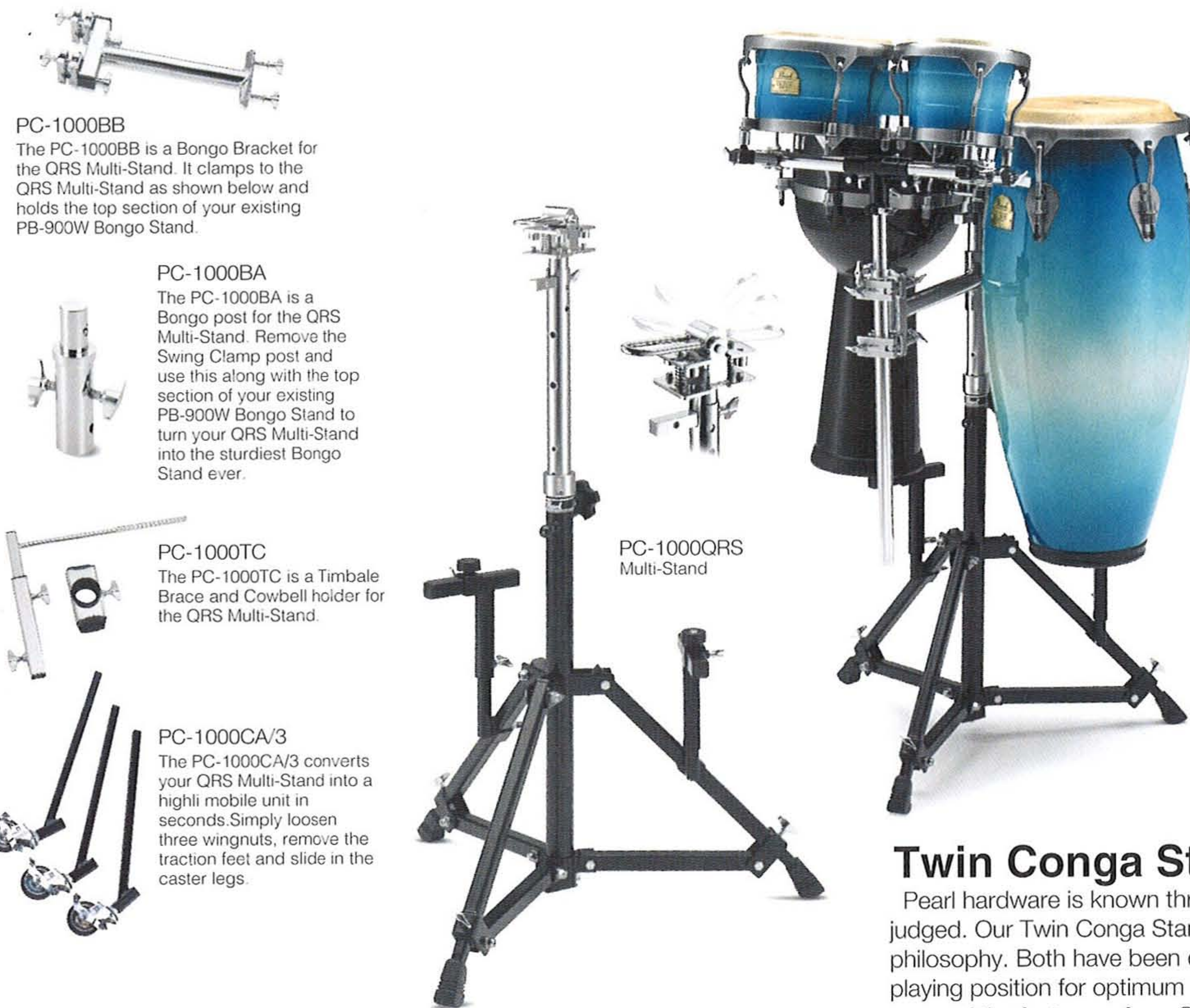

PC-1000BB
The PC-1000BB is a Bongo Bracket for the QRS Multi-Stand. It clamps to the QRS Multi-Stand as shown below and holds the top section of your existing PB-900W Bongo Stand.

PC-1000BA
The PC-1000BA is a Bongo post for the QRS Multi-Stand. Remove the Swing Clamp post and use this along with the top section of your existing PB-900W Bongo Stand to turn your QRS Multi-Stand into the sturdiest Bongo Stand ever.

PC-1000TC
The PC-1000TC is a Timbale Brace and Cowbell holder for the QRS Multi-Stand.

PC-1000CA/3
The PC-1000CA/3 converts your QRS Multi-Stand into a highly mobile unit in seconds. Simply loosen three wingnuts, remove the traction feet and slide in the caster legs.

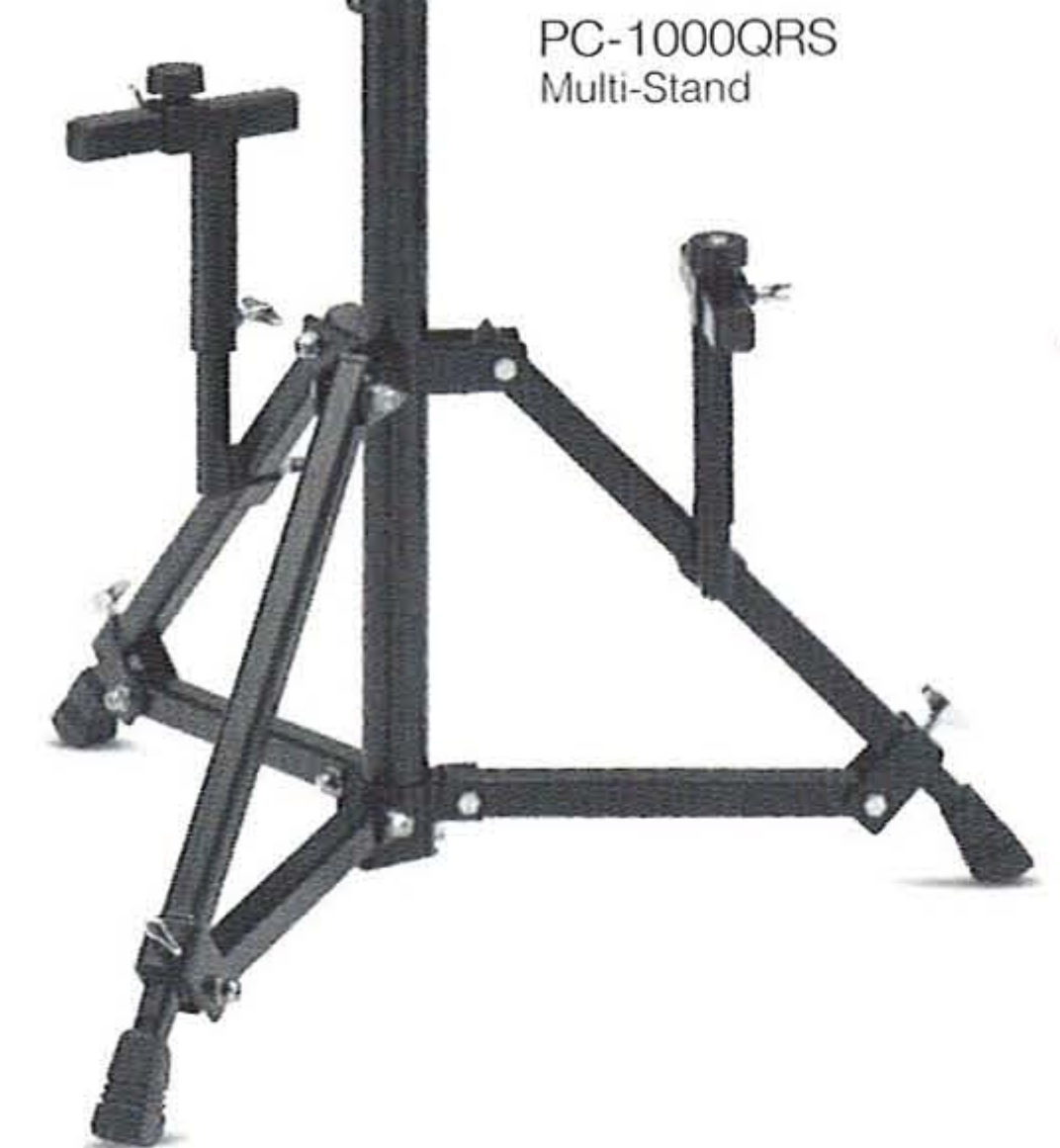

PC-1000QRS Multi-Stand

Twin Conga Stands

Pearl hardware is known throughout the drum industry as the standard by which all others are judged. Our Twin Conga Stands are two perfect examples of our rock solid, dependable design philosophy. Both have been designed to allow you to mount two full size Pearl Congas at the perfect playing position for optimum performance. Our super sturdy PC-950TW Twin Conga stand shares many of the features of our QRS Multi-Stand, but it is designed for traditional wingnut style Conga mounting. Full height adjustability, individually extendable tilting legs, adjustable drum supports, and a super sturdy heavy duty steel base are all outstanding features of the PC-950TW. Our PC-200W Twin Conga Stand provides great dependability at a very affordable price. It offers full height adjustments, a dual drum support, and sturdy double braced leg tripod.

ALL-Fit Stand

If you have the need to mount a variety of different drums, or just want a stand that does it all, there is no better choice than our PC-900 All-Fit Stand. The PC-900 holds Congas, Djembes, Cajons, and countless other drums with ease. Its widely adjustable tension strap design and individually telescoping legs, provide height and angle adjustments that open up a wide array of set-up positioning possibilities. Individual sliding drum supports are also provided on each leg support, and can be positioned inside or outside the drum's base for super sturdy mounting and grip of virtually any hand drum.

Bongo Stands

A great Bongo stand is a must for adding Bongos to your live percussion set-up. Our PB-900W Bongo Stand will fit virtually any Bongo set on the market. It grips them at the center connecting post and also provides great support at both ends under the tension bolts. Its unique, sturdy, adjustable design also allows you to tilt the Bongos for better set-up positioning. Our PB-700 Bongo stand is a great choice for both performance and value. It features a center gripping "L" clamp to securely mount your Bongos, and provides a single braced leg tripod and full height adjustability with a memory lock function to remember your set-up positions.



PC-950TW Heavy Duty Twin Conga Stand

PC-200W Primero Twin Conga Stand

PC-900 All-Fit Stand

PB-900W All-Fit Tilting Bongo Stand

PB-700 Lightweight Bongo Stand

HOLDERS and Accessories

Pearl's various holders and accessories make it easy to build an exciting percussion set-up as individual as your signature. PPS-31. The PPS-31 provides an easy, simple way to add a small cymbal to any stand. PPS-30. Our PPS-30 is a straight single post for mounting a cowbell or other accessory to most any stand. PPS-37. The PPS-37 is a 360° adjustable angle post with heavy duty, quick release clamp that provides great flexibility when mounting a Cowbell or accessory.

PTT-1212. Need a place to shelve your Sticks, Shakers, Ganzas and accessories while you're playing hand drums? Then you can't do without Pearl's new PTT-1212 Percussion Table. Comes complete with clamp for stand mounting and cutouts to keep your sticks from rolling off. PPS-51. Our PPS-51 is a Mini Rack with 2 posts for mounting Bells and accessories. PPS-52. Got more Bells? Then the 4 post PPS-52 is the answer. It provides 2 angled posts and 2 straight post for mounting Bells above and below the rack.

PPS-10. The PPS-10 and PPS-11 Stix Free allow you to play a Cowbell by hand to incorporate new rhythms while playing hand drums. Stix Free is a Pearl exclusive and easily mounts to the post of any cowbell holder. Available in 2 sizes, PPS-10 for small bells up to 5", and PPS-11 for larger size bells. PPS-15. The revolutionary PPS-15 provides a super sturdy Cowbell mount for your bass drum pedal. It allows you to play a clave or other cowbell beat with your foot while playing hand drums, Timbales or drumset. A great addition to any set-up.

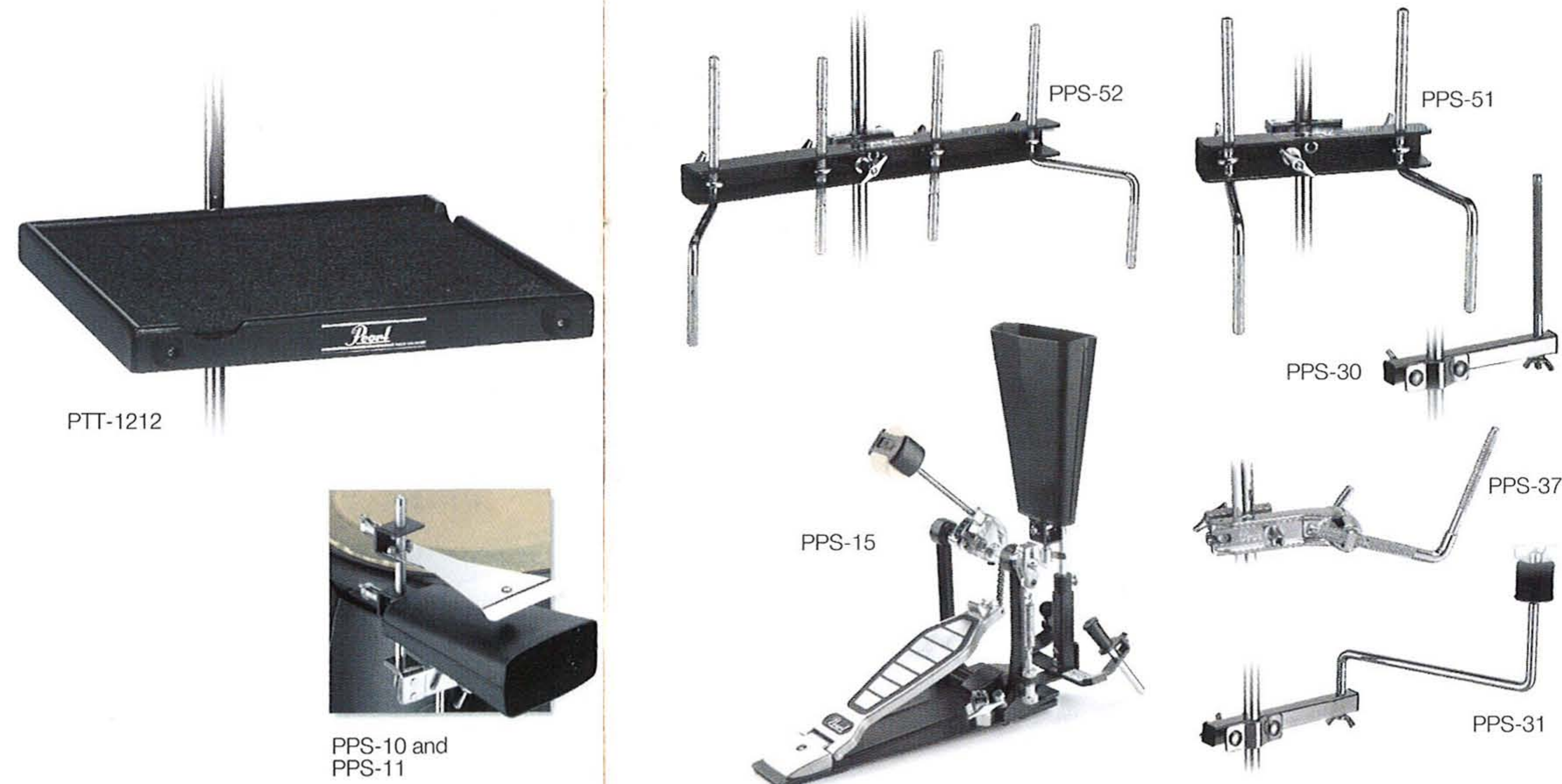

PTT-1212

PPS-10 and PPS-11