



Pearl DRUM PEDALS and HARDWARE



Pearl[®]

PowerShifter Eliminator Pedals

PowerShifter ELIMINATOR



Pearl's original PowerShifter pedal took the drumming world by storm soon after its release in 1996. Never before had a pedal offered such speed, power and smoothness, combined with the unheard ability to perfectly custom tailor the feel of the pedal specifically to each player's needs. The PowerShifter function was revolutionary, with no pedal before or since offering this amount of total control...until now.

Introducing the all new PowerShifter Eliminator from Pearl. If our original PowerShifter pedal was revolutionary, the all new Eliminator is simply extraordinary in every way. The all new PowerShifter Eliminator features our exclusive Interchangeable Cam System, providing 4 completely different drive cams from which to choose. From radically aggressive power to maximum finesse, and every nuance in between, one push of a button is all it takes to change from one cam to the next. This incredible Cam System effortlessly meets the needs of any player and any style of music. After choosing a cam, our PowerShifter function then allows you to move the footboard to further fine tune the feel and power of the pedal. PowerShifter Eliminator is available with your choice of either dual chain or belt drive systems. For players that prefer a belt drive over chain, PowerShifter Eliminator offers a belt drive model that features a new extremely strong, highly durable drive belt for a super smooth, solid feel, that no other pedal can match. With all these available options, any player can easily custom configure the pedal of their dreams.



Chain Drive

Pearl's double chain drive glides silently within the cam channel providing a super smooth, quiet, powerful precision feel. Since there are no sprockets involved, there is much less wear on the chain and less noise in the studio.

Belt Drive

Our newly designed Belt Drive provides a very comfortable, natural feel very similar to a direct drive system. We use a new extremely strong, highly durable drive belt, instead of a normal rubber strap, to provide maximum durability, strength, and stretch resistance.

- Interchangeable Cam System
- Wide Tension-Range Spring
- PowerShifter function
- New Footboard design
- Traction Plate with Traction Grips
- Quad Beater
- Floating Spring Pendulum
- Infinite Beater Angle with gauge
- Adjustable Height Footboard
- Adjustable Roller Cam Hoop Clamp
- Power Plate

P-2000C
PowerShifter Eliminator
CHAIN DRIVE
Pedal



P-2000B
PowerShifter Eliminator
BELT DRIVE
Pedal



- Interchangeable Cam System
- Wide Tension-Range Springs
- PowerShifter function
- New Footboard design
- Traction Plate with Traction Grips on both pedals
- Quad Beaters
- Floating Spring Pendulum
- Infinite Beater Angle with gauge
- Adjustable Height Footboards
- Adjustable Roller Cam Hoop Clamp
- Power Plate
- Aircraft Quality Aluminum Drive Shaft

P-2002B
PowerShifter Eliminator
BELT DRIVE
Double Pedals



P-2002C
PowerShifter Eliminator
CHAIN DRIVE
Double Pedals



- The Black Cam is factory installed on P-2000C PowerShifter Eliminator Chain Drive Pedals. In addition, three other cams: White, Blue, and Red are included.
- The Red Cam is factory installed on P-2000B PowerShifter Eliminator Belt Drive Pedals. In addition, three other cams: Black, White, and Blue are included.

- The Black Cams are factory installed on P-2002C PowerShifter Eliminator Chain Drive Double Pedals. In addition, White x 2, Blue x 2, and Red x 2 Cams are included.
- The Red Cams are factory installed on P-2002B PowerShifter Eliminator Belt Drive Double Pedals. In addition, Black x 2, White x 2, and Blue x 2, Cams are included.

Interchangeable Cam System

(US.PAT.6172291)

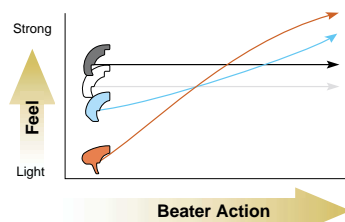

Our exclusive Cam System provides four interchangeable color-coded cams allowing you to quickly change the power and feel of the pedal to suit your individual playing needs. Changing from cam to cam is as simple as pushing the release button and snapping another cam in place.

Black
Linear Action Cam

This is Pearl's original sized "perfect circle" Cam design. It offers superior power and a very natural, perfectly well-balanced action and smooth feel.

White
Oversized Linear Cam

The White Cam is a slightly over sized "perfect circle" Cam. It offers a very natural, smooth action, with great power and balance, with a slightly lighter pedal feel.

Blue
Progressive Cam

This is the very popular "off-center" axis type cam design. It offers a lighter feel in the beginning that accelerates with speed and power upon impact.

Red
Radical Progressive Cam

The Red Cam features an extreme "off-center" axis design. It provides traditional action with great response to sensitive footwork and extreme power upon impact.

New Footboard Design

Our all new Footboard design offers perfect balance, great stability and extreme player comfort. By redesigning every aspect of the footboard, including spring tension, beater weight and pedal shape, we have created the most powerful feeling Bass Drum Pedal available.



Independent Traction Grips

Power Shifter Eliminator's all new Traction Plate footboard insert allows you to remove and reconfigure each individual traction grip to suit your exact playing requirements. From maximum grip to full slide, and every option in between, the choice is yours. The Traction Plate also reverses to focus the slide or grip surfaces to either the toe or heel of the pedal. (PAT. PEND.)



Wide Tension-Range Spring

Our all new counter spring has been designed to perfectly compliment the weight and balance of the footboard and beater assembly. It also offers a much wider range of adjustability allowing you to fine tune the pedal tension to suit your playing style.

Uni-pressure Spring Clamp

Our Uni-Pressure Spring Clamp System grips a full 360 degrees and allows infinite beater angle adjustments. Featuring a unique Floating Spring Pendulum design that is perfectly centered on the clamp, this system offers full precision bearing movement for unmatched smoothness.

PowerShifter Function

Our revolutionary PowerShifter function provides 3 positions to fine tune the power and feel of the pedal. By moving the footboard forward or back you change the chain or belt drive angle, thus changing the leverage to create a light, normal or strong feel. (US.PAT. 5574237)

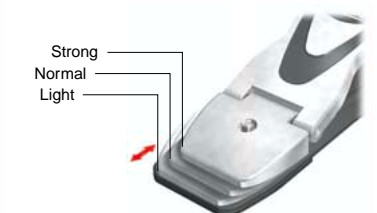

Quad Beater

Our original Quad Beater provides four different beater surfaces, each with its own distinct sound. You can choose from 2 hard plastic surfaces or 2 felt surfaces and either pinpoint or line contact with the head. You also have a sliding memory lock so you will always remember your perfect set-up. (US.PAT. 5610351)

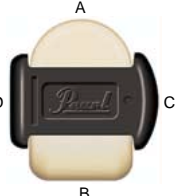

A: Face : Felt. Contact area : Spot. Sound : Warm with Sharp Attack
B: Face : Felt. Contact area : Line. Sound : Warm with Dull Attack
C: Face : Plastic. Contact area : Spot. Sound : Hard with Sharp Attack
D: Face : Plastic. Contact area : Line. Sound : Hard with Dull Attack

Footboard Adjustment

Footboard angle is easily adjusted completely independent of beater angle allowing you to further fine tune the feel and action of your pedal.

Roller Cam Hoop Clamp

Our redesigned Roller Cam Hoop Clamp multiplies each turn of the adjustment knob to speed the process of attaching the pedal to the hoop. It fits an extremely wide range of hoop thicknesses and offers the smoothest, most secure grip possible.

PowerShifter Drum Pedals

Pearl's PowerShifter pedals push the limits of existing pedal design, setting new standards for speed, power, and smoothness.

PowerShifter pedals can be custom tailored to alter the feel from light to heavy, echoing every nuance and inflection of the player at any tempo.

Our PowerPro pedal line feature a DuoBeat beater system and the same footboard design as its sibling, PowerShifter.

Our value packed P-70 pedal features a rugged belt-drive system and our DuoBeat beater system. Both PowerShifter and PowerPro twin pedals include all the benefits of their single pedal counter parts, including speed and smoothness, as well as providing excellent feel, stability, and positive action.

The low-mass aircraft quality aluminum drive shaft of our twin pedals, features precision universal joints for superb tracking, sensitivity and control.

Twin pedal conversions are also available for PowerShifter and PowerPro single pedals, and all models are available in either left or right handed versions.

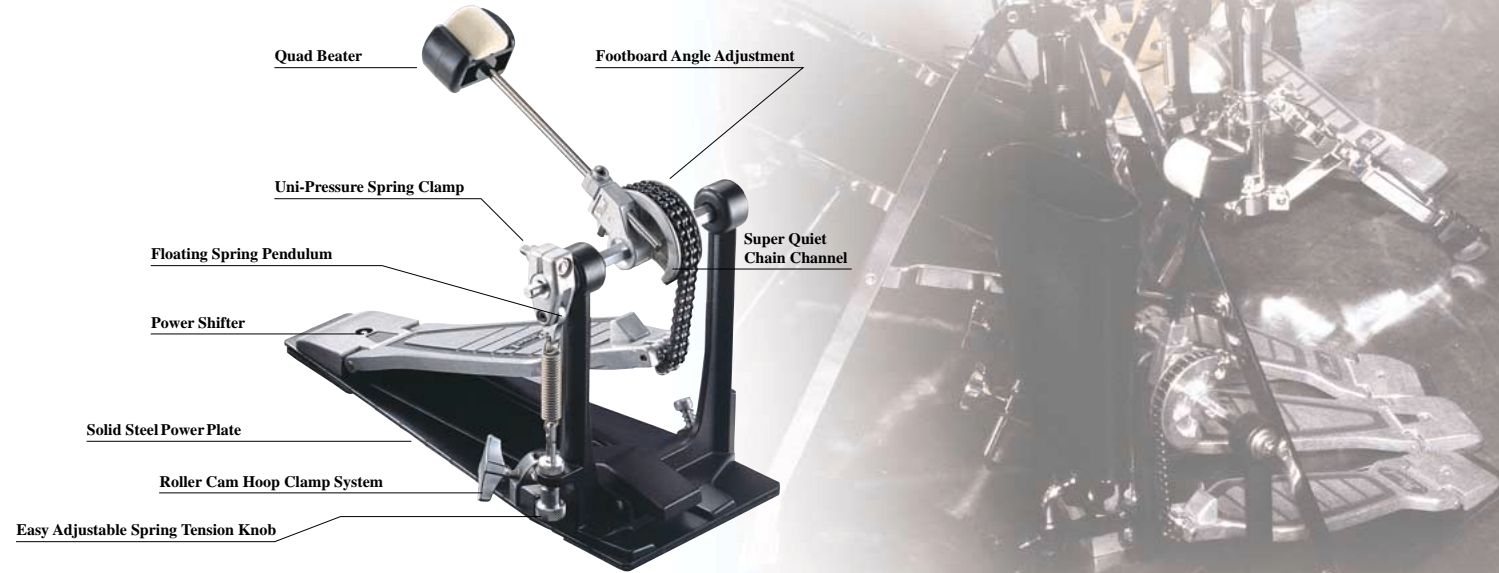

P-201P

- PowerShifter Function
- Quad Beater
- Double Chain Drive
- Floating Spring Pendulum
- Infinite Beater Angle
- Adjustable Height Footboard
- Roller Cam Hoop Clamp System
- PowerPlate



P-101

- Quad Beater
- Single Chain Drive
- Floating Spring Pendulum
- Infinite Beater Angle



P-101P

- PowerShifter Function
- Quad Beater
- Single Chain Drive
- Floating Spring Pendulum
- Infinite Beater Angle
- Roller Cam Hoop Clamp System
- PowerPlate



P-100

- "DuoBeat" Two Way Beater
- Single Chain Drive
- Spring Tension Adjustment
- Silent, Smooth Chain Channel



P-202TW

- PowerShifter Function
- 2 Quad Beaters
- Double Chain Drive on both pedals
- Floating Spring Pendulum
- Infinite Beater Angle
- 2 Adjustable Height Footboards
- Roller Cam Hoop Clamp
- PowerPlate
- Aircraft Quality Aluminum Drive Shaft

P-202TWL

Twin Pedal Complete for Left-handed Players

P-201TW

Twin Pedal Primary Side Only



P-100TW

- "DuoBeat" Two Way Beaters
- Single Chain Drive on both pedals
- Spring Tension Adjustment
- Roller Cam Hoop Clamp (main pedal only)
- Silent, Smooth Chain Channel
- PowerPlate
- Aircraft Quality Aluminum Drive Shaft

Power Shifter

Our revolutionary PowerShifter function is a major advancement in pedal technology. By "shifting" the footboard forward or back, the leverage and thus the feel of the pedal is altered from light, medium, and heavy to suit your personal playing style. (US.PAT. 5574237)

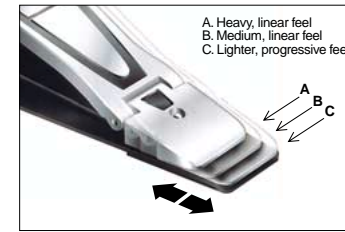

Super Quiet Chain Channel

All Pearl chain drive pedals feature toothless cams with felt-lined channels for efficient power transfer and totally silent operation, a must for recording. Single and double chain versions are available.

Uni-Pressure Spring Clamp

The Uni-Pressure Spring Clamp provides infinite beater angle adjustment for perfect stroke length and balance without changing spring tension.



Footboard Angle Adjustment

The chain on the P-201P adjusts to three positions to customize the footboard angle to your individual playing style without changing beater angle and spring tension.



Floating Spring Pendulum

The spring is attached directly in-line with the rocker cam (not off to the side) for maximum efficiency. The integrated spring roller features precision needle bearings and contributes to the Power Shifter / Power Pro's extraordinary smoothness and incredible speed. The spring is dampened with felt to assure silent action in all playing situations.

Quad Beater

Our patented Quad Beater features two plastic and two felt surfaces. One face of each pair produces a sharp attack; the other, a fat attack thus giving the Quad Beater four distinctly different sounds. The provided square Stop-Lock assures perfect head / beater alignment and quick sound changes. (US.PAT. 5610351)

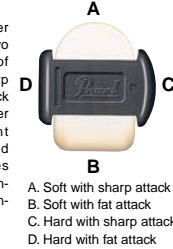

DuoBeat

The new DuoBeat Beater offers two different faces, plastic and felt, adding great versatility of sound over single beaters. It's like getting two beaters for the price of one.

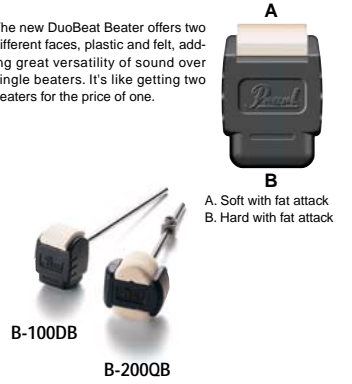

B-100DB

B-200QB

Pedal Stabilizer

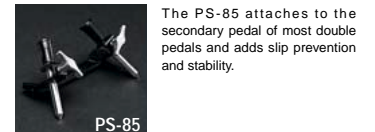

PS-85

The PS-85 attaches to the secondary pedal of most double pedals and adds slip prevention and stability.

Solid Steel Power Plate

The Power Plate adds rigidity and stability to focus 100% of your energy into the bass drum.

Easy Adjustable Spring Tension Knob

Our oversize spring tension knobs provide solid grip and easy adjustment without tools.



Eliminator Hi-Hat

Pearl's all new Eliminator Hi-Hat represents the smoothest, most natural feeling Hi-Hat drive system ever designed. This revolutionary Hi-Hat is a complete departure from normal Hi-Hats, offering feature after feature to set new standards for function, adjustability, and above all, playing comfort. The totally natural feel of our Eliminator Hi-Hat is centered around its new PosiLink Twin Cam Drive System. PosiLink's interchangeable Drive Cam and interactive double chain design, together with other outstanding features like our new Super-Grip Clutch, VariSet Footboard Angle Adjustment System, exciting Power-Shifter function, and reversible TractionPlate footboard, add up to a Hi-Hat that performs as if it were an extension of your thoughts.

PowerShifter ELIMINATOR

PosiLink Twin Cam Drive System

This completely new and exclusive Hi-Hat drive system utilizes two cams and two double link chains, working together, to provide the smoothest, quietest, most natural feeling Hi-Hat action ever imaginable. No other system can provide the extreme torque, natural response and tight, crisp Hi-Hat sound offered by this exciting innovation in Hi-Hat drive design. We've even replaced the normal felt washer on the lower pull rod return with a spring. This helps to further quieten the pedal when removing your foot, and adds greatly to the pedal response while playing. (PAT.PEND.)

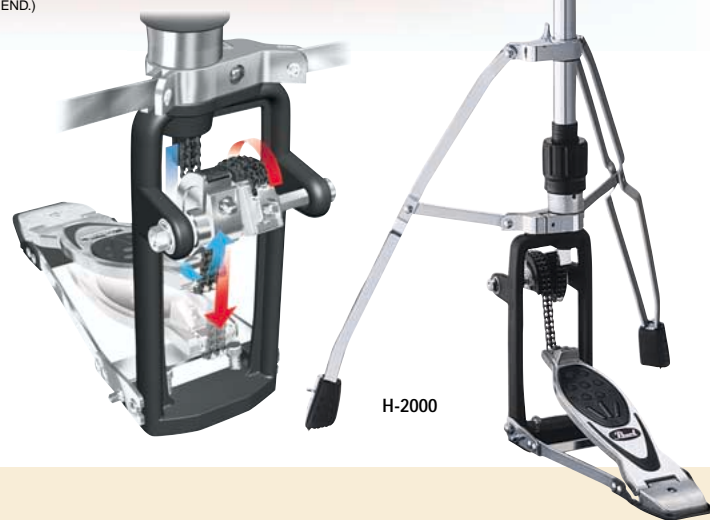

H-2000

Interchangeable Cam



You can easily custom tailor the response curve and action of the Eliminator Hi-Hat by choosing between four different cam options. Our Black Cam provides a smooth, constant, very natural linear action. Our White Cam is also Linear but with a slightly lighter feel. The Blue Cam accelerates with speed and power as it's played and our Red Cam is the most radical and aggressive. This system allows you to play as normal or as aggressive as you like and can be used to offset the feel of heavier cymbals. Each Eliminator Hi-Hat includes all four cams. (PAT. PEND.)

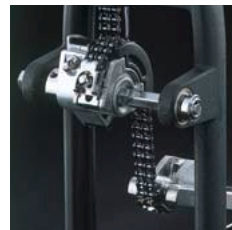

VariSet Footboard Angle Adjustment

Unlike "gear" type adjustment systems common with other Pedals and Hi-Hats, our VariSet system allows you to effortlessly rotate the pull cam to change the angle of the footboard offering a much wider range of angle adjustability. The pedal height can also be adjusted on the pedal cam side, allowing you to also quickly compensate for the difference in footboard heights produced by interchanging the cams.

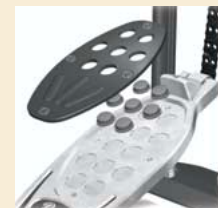

TractionPlate Footboard

This new concept in footboard design is shared with our Eliminator Bass Drum Pedal and allows you to remove and reconfigure each individual traction grip to suit your exact requirements. The TractionPlate is also reversible allowing you to position the slide or grip of the plate at either the front or rear of the pedal.



PowerShifter

This revolutionary function, first introduced on our now famous PowerShifter Bass Drum Pedal, allows you to move the footboard to one of three preset positions. This changes the angle of the pull chain and thus allows you to adjust the feel and action of the Hi-Hat from a light feel, to one with extreme power and torque.

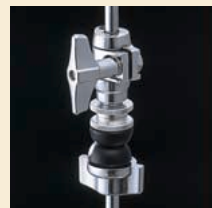

SuperGrip Clutch

Our all new SuperGrip Clutch design is the strongest, most dependable system available today. It features a completely solid upper and lower tunnel design with a center gripping hinge to hold your upper Hi-Hat Cymbal securely like no other clutch has ever done before. It also features a new die-cast wingnut designed to allow you to easily and securely tighten the cymbal.



Precision Spring Tension Dial

Eliminator's new Precision Spring Tension Dial is engineered with a multitude of exact steps allowing you to precisely and quickly dial in your optimum tension setting. This innovative system offers a far greater tension range and its exact locked-in steps will not slip or move under stress.

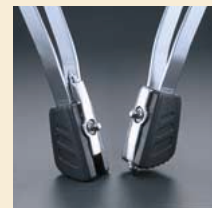

New Reversible Rubber / Spiked Tipped Feet

Our newly designed convertible rubber feet feature an attached steel spike that can quickly be rotated into place providing the ultimate in traction when needed.

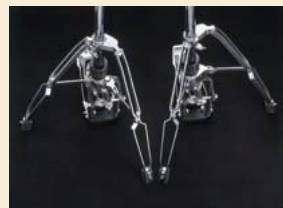

Swiveling Dual-Legs

Eliminator's new Swiveling Dual-Legs allow perfect positioning with Twin Bass Drum Pedals and other accessory pedals while still maintaining a firm, stable stance. Its offset post design also provides closer positioning with your snare drum while leaving the pedal in the normal playing position.

Hi-Hat Stands

All Pearl hi-hats feature internal pull springs for superior performance and speed. Unlike compression springs that rub causing friction and slowness, Pearl's pull springs are virtually friction free for silent operation, silky smoothness, and incredible speed. The H-985W Vari-Link Hi-Hat provides infinite footboard height adjustments for comfort and speed. The spring tension screw is conveniently positioned within easy reach for tension adjustments while playing. The clutch spacers and seat cup are specially formed from non-sound absorbing rubber to maximize cymbal clarity and projection. The H-885 features unique Roller Pulley System which requires half the effort of direct drive hi-hats, providing a lighter feel when using heavier cymbals, and also features full footboard angle adjustability. Both of the H-885 and H-855 features swiveling legs and reversible Spike/Rubber tips. The H-800W PowerPro Hi-Hat features double braced swiveling legs, adjustable spring tension, our CL-68 clutch, and is built to Pearl's legendary quality standards, offering a great value.

Hi-Hat Clutch



The CL-98P hi-hat clutch grips the pull rod at three points for dependable, slip-proof performance. Minimal contact rubber washers allow the cymbals to ring freely creating an open, lively sound, with clarity that must be heard to be believed.

Cymbal Seat



Our new rubber cymbal seat contacts the cymbal at only three points for a noticeable improvement in both resonance and clarity. Each contact is contoured to help keep the cymbal centered for a consistent sound. Standard on the H-985W.

Spike / Rubber Tips



The H-985W features reversible spike/rubber tip feet for slip-resistance on all types of flooring surfaces. The foot also rotates to allow precise adjustments for best stability.

Spike / Rubber Tips



The H-885 and H-855 Hi-Hats feature fixed position reversible spike/rubber tips for extra stability.

Spring Tension Adjustment



The H-985W's new spring tension adjustment system is ergonomically located for easy reach allowing adjustments while playing.

Vari-Link System



The Vari-Link System features an adjustable linkage for infinite footboard angle settings. The footboard angle can be set for optimum playing comfort and to match the height of double pedals providing quick transitions.

Swiveling Legs



Pearl hi-hats feature full swiveling legs making them perfect for use with double pedals and various other accessory foot pedal set-ups. Swiveling legs are standard on H-985W, H-885, H-855 and H-800W models.

Roller Pulley System



The H-885's Roller Pulley System is the smoothest Hi-Hat system available. Its dual rotating wheels swivel as they move to offer an amazingly light and swift action. The footboard angle is also completely adjustable for comfort. (US.PAT 5018426)



- Rubber Cymbal Seat
- Easy Reach Tension Adjustment Knob
- Vari-link footboard height adjustment System
- Omni-Pod Swiveling Legs
- Reversible Spike/Rubber Tipped Feet

H-985W

- Roller Pulley System
- Omni-Pod Swiveling Legs
- Adjustable Height Footboard
- Reversible Spike/Rubber Tipped Feet

H-885

- Omni-Pod Swiveling Legs
- Reversible Spike/Rubber Tipped Feet

H-855

- Omni-Pod Swiveling Double Braced Legs
- Adjustable Spring Tension

H-800W

- Double Braced Legs

H-70W

Closed Hat

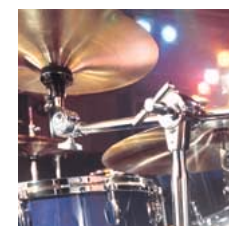

The new CLH-100 features a boom arm with stop-lock and Pearl's infinitely adjustable Uni-Lock tilter for ultra-precise positioning, versatility, and ease-of-use.



CLH-100

Optional Drop Clutch

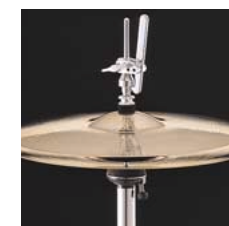

The DCL-90 Drop Clutch closes the hi-hats without foot pressure. This allows playing "two-footed" patterns and closed hats at the same time. Normal hi-hat play is resumed by simply stepping on the footboard.



DCL-90

Hi-Hat Attachment

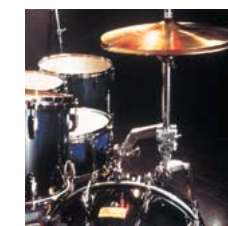

The HA-95L Hi-Hat attachment secures the hi-hat next to the bass pedal on double bass set-ups for easy reach and quick transitions.



HA-95L

Drum Thrones

Pearl's new top of the line Roadster thrones are made with the touring musician in mind. Their solid steel "PanHead" seat base promotes a lower center of gravity which in turn provides a more stable, totally secure, drumming foundation. All Pearl thrones now feature a new highly durable, die-cast seat clamping system for extra durability, and Roadster Thrones provide a super strong, one step locking collar to securely lock-in your height adjustment. Our Roadster D-220, D-150 and D-150S thrones feature a new super comfortable AirFlo fabric covered cushion that allows the seat to breathe, providing optimum comfort during those extended gigs. Our D-220C and D-150C feature a new plush seat top for the most luxurious comfort imaginable. Our Roadster D-150S provides a shorter height stance for players that like to sit low. Our standard series D-80 throne provides a sturdy double leg tripod, easy height adjustment and a smaller style bike seat designed of both speed and comfort. Our D-75 provides a round vinyl covered seat with all the same outstanding features as the D-80. Our D70W features double braced legs for maximum stability, and a vinyl covered round seat designed for comfort.



Plush seat top



AirFlo fabric cushion



NEW Roadster D-220C (Plush)
Height Adjusts from 440 - 600mm



NEW Roadster D-220 (AirFlo fabric)
Height Adjusts from 440 - 600mm



NEW Roadster D-150 (AirFlo fabric)
Height Adjusts from 450 - 610mm



NEW Roadster D-150S (AirFlo fabric)
Height Adjusts from 405 - 560mm



NEW Roadster D-150C (Plush)
Height Adjusts from 450 - 610mm



D-80
Height Adjusts from 430 - 680mm



D-75
Height Adjusts from 430 - 680mm



D-70W
Height Adjusts from 430 - 650mm



Redesigned Seat Clamping System

Our Roadster thrones feature a newly designed die-cast seat clamping system which offers strength, perfect stability, and security.



Newly designed Spiral Joint

Our D-220 and D-150 Roadster Thrones feature a new super strong one step locking collar for their twist post height adjustment.



Standard Height Adjustment Joint

Our D-80, D-75 and D-70W model Thrones feature a compression collar with nylon bushings for secure height adjustments. A stop-lock is provided for added slip resistance.

Snare Stands

Our top of the line S-985W Snare Stand features a dual pivoting Uni-Lock basket angle adjustment system for state of the art precision. Other features include oversized rubber snare grips, nylon sleeved pipe joint for smooth action, and sturdy double braced legs with reversible rubber/spike feet. Our S-885W offers all the outstanding features of the S-985W without the reversible spike feet. Our S-850 features a Uni-Lock basket tilter, oversized snare grips, nylon sleeved pipe joint and sturdy single braced legs.



- Dual Uni-Lock Basket Angle Adjustment system
- Reversible Rubber/Spike Feet
- Dual Uni-Lock Basket Angle Adjustment system
- Uni-Lock Basket Tilter
- Gear System Basket Tilter
- Gear System Basket Tilter



Dual Uni-Lock Basket Angle Adjustment System

The Uni-Lock System provides infinite angling for precise snare drum positioning. Our S-985W and S-885W feature dual-action Uni-Lock tilters for simultaneous fore/aft and left/right positioning for perfect drum placement every time.



Spike / Rubber Tips

The S-985W features spike tips for additional slip-resistance on any floor surface. Its reversible feet also pivot permitting the tips to remain perpendicular to the floor regardless of tripod spread.



Snare Basket Adapter

The SBA-1 fits onto the tips of any Pearl snare stands to accommodate 12" diameter snare drums. Sold in sets of three.

Cymbal Boom Stands & Cymbal Stands

Pearl cymbal and boom stands offer the unmatched quality and features that have made them the absolute finest available today. All 855 series stands feature our patented Uni-Lock infinitely adjustable tilters for precise cymbal positioning. 855 and 800 series boom stands are equipped with boom arm Stop-Locks for slip prevention and quick set-ups. For value, nothing beats our new PowerPro series Cymbal and Boom stands. The PowerPro B-800W and C-800W offer double braced legs, three sections, slim-line pipe joints, and superior Pearl quality at unbeatable pricing.



- Uni-Lock Tilter
- Uni-Lock Tilter
- Gear Tilter
- Gear Tilter

Boom / Straight Cymbal Stand

NEW BC-800W



Pearl's new BC-800W can be used as either a traditional straight cymbal stand, or as a boom stand, to double your options in positioning cymbals. The top section can be used in a vertical position as a normal straight cymbal stand or be adjusted into an angled position to turn it into a full featured boom stand.

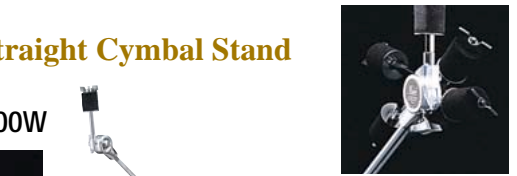

Uni-Lock Tilter

Our Uni-Lock Tilter features an internal "brake drum" type locking system for infinite angling possibilities and slip-proof dependability.



Boom Arm Stopper

All 855 series and 800 series boom stands feature Stop-Lock equipped boom arms for quick, repeatable set-ups and 100% slip-prevention.



Nylon Bushing Joint

All 855 series stands feature non-marring nylon bushings for slip-proof height settings and long-lasting beauty.



New SlimLine Joint

The Power Pro series stands feature our new SlimLine pipe joints for outstanding visual appeal and nylon sleeves to assure perfect vertical alignment of the all cymbal tubes.



- Uni-Lock Tilter
- Uni-Lock Tilter
- Gear Tilter
- Gear Tilter

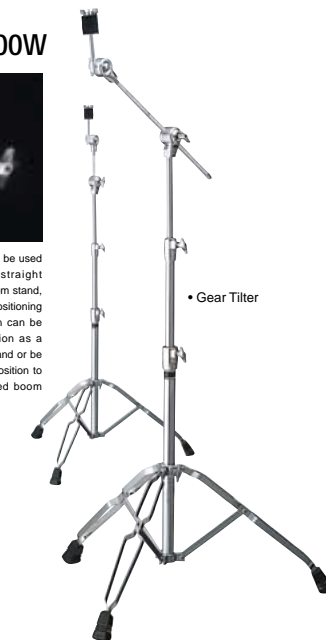

Tom Stands & Combination Stands

Pearl tom stands are available in both single and double braced versions with gear-type, or infinitely adjustable Uni-Lock tom holders. All models feature AX-35 clamps with quick release jaws for the most secure grip possible. Our T-980W provides sturdy double braced legs and comes complete with two top of the line TH-100S tom holders. Our T-900W offers the same stability, but features our patented TH-98S tom holders. Our T-800W stand features deep-gear tilters tom holders. Our TC-980W and TC-900W stands offer a combination to hold both a tom and a cymbal, providing an easy and compact alternative to the clutter of multiple single stands.

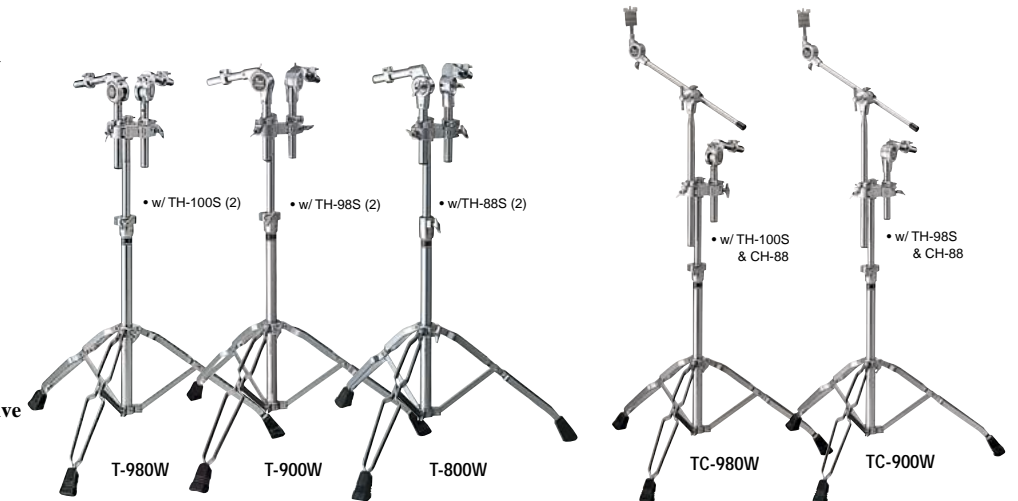

- w/ TH-100S (2)
- w/ TH-98S (2)
- w/ TH-88S (2)

- w/ TH-100S & CH-88
- w/ TH-98S & CH-88

Drum Racks



ICON Rack

Our patented non-slip square tube rack design has always separated Pearl from the pipe puzzle type designs offered by others. Our ICON Rack System provides independent control over the height of each tube and its square aluminum tube design insures your mounts will not spin or loosen after they're positioned. ICON also provides square stabilizer feet offering the most sturdy, rock solid rack on the market today.

DR-500
The DR-500 features three independently height adjustable sections: a front and two sides. Quick release couplers and memory clamps insure a quick, accurate set-up, time after time. Additional DR-500E extenders can be purchased, 1leg and one side, for double bass and custom set-ups. Includes four PC-50 pipe clamps.

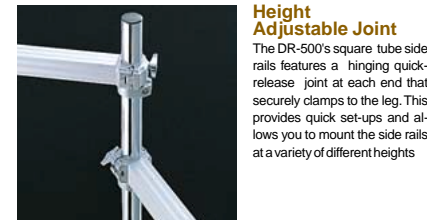

Height Adjustable Joint
The DR-500's square tube side rails features a hinging quick-release joint at each end that securely clamps to the leg. This provides quick set-ups and allows you to mount the side rails at a variety of different heights.



Pipe Clamps
PC-50 and PC-8 pipe clamps feature hinged quick release jaws for quick set-ups. Both accommodate 7/8" posts and SX-2 Stop-Locks. The reissued PC-10 features heavy-duty adjustable jaws capable of accommodating a wide range of tubing sizes.



Rack Joint
The RJ-50 is ideal for joining two DR-500L ICON racks together for double bass or extended set-up applications.



DR-80
The DR-80 is a lighter weight three section rack with fixed-height legs that folds for easy transport. Includes four newly designed PC-8 pipe clamps.

O.P.S.S OptiMount Suspension System

Our new OptiMount Suspension System attaches to the tom's tension rods and floats on rubber cushions, providing the ultimate in stability while allowing the drum to resonate fully unrestricted. With OptiMount, the mounting hardware is completely removed from the drum shell, providing a drastic improvement in resonance and sustain.



I.S.S Integrated Suspension System

Our standard I.S.S. mounts also remove all mounting hardware from the shell and clamp to the rim providing the quickest, easiest mounting system available today. (PATENTED / US.PAT 5544561)



Jungle Gig

The new JG-16 Jungle gig adapter from Pearl converts your floor tom into a bass drum without drilling any holes or making permanent changes to the shell. The new Jungle Gig adapter consists of two spurs, a height tube and a pedal mounting plate, and is intended to be used with the Pearl I.S.S. mount and BT-3 tom bracket. To make the conversion to an instant jungle - type drumset, it is as easy as turning the floor tom on its side, changing over the legs, fitting the bracket, then adding the toms and snare drum.



Cymbal Holders

Pearl's cymbal holders offer the easiest way to add cymbals to your rack set-up or adding extra cymbals to your standard set-up with stands. Our CH-88L offers a super long reach, our patented Uni-Lock internal braking system tilter, and an oversized counterweight perfect for long reach or heavier cymbals. Our CH-88 is the standard length version without counter weight and our CH-80 substitutes a deep gear tilter instead of Uni-Lock. Our CH-70 is perfect for adding splash and crash cymbals to any set and comes complete with an adapter clamp.



Tube Extender

TX-80
Our TX-80 Tube Extender allows you to increase the reach or height of any cymbal arm, tom arm or stand that uses a standard 7/8" diameter pipe. For a stand, simply remove your existing pipe, slide in the TX-80 and slide your existing pipe into the TX-80.

Tom Holders

Pearl tom holders are available with both our patented Uni-Lock (infinity adjustable) or gear-type tilters, and in both standard and short length versions. Our totally new TH-100 series Uni-Lock Multi-Directional Tom Holder provides a super smooth, gear-less continuous feel and rotates both horizontally and vertically without changing the height or rotation within the bass drum or tom stand mount. Our TH-100L, TH-98I and TH-88I feature short arms for use with OptiMount or I.S.S. equipped toms.



Training Pads

TK-100/ TK-200
The TK-100 is a compact practice kit with rack-type styling for flexibility and realistic positioning. The newly designed rubber pads are extremely quiet and perfect for use in "sound-sensitive" environments. The TK-200 is the double bass version and features two bass drum pads.



Silencer Pads

SD-50
The SD-50 features Pearl's newly designed rubber practice pad with realistic rebound and near silent performance. The stand and pad use heavy-duty 8mm threading for superior durability and stability.

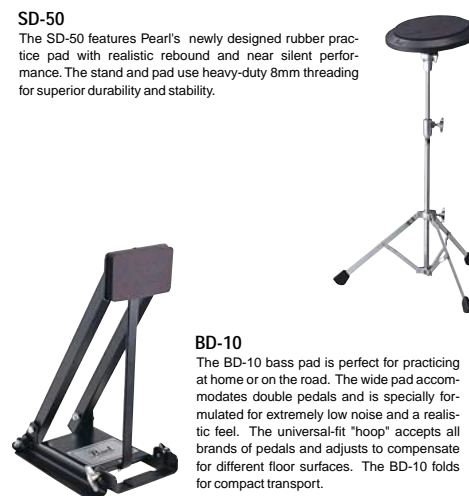

RP-50
Our RP-50 features five rubber discs for silent practicing on a traditional drumset. Sizes include 12", 13", 14", and 16" pads (to fit most drum sets) and universal-fit bass pad with adjustable straps.

RP-40C
Our RP-40C rubber cymbal pads quickly silence your cymbals and feature of a 14" hi-hat disc, and a crash and ride cymbal pad.

Adapters

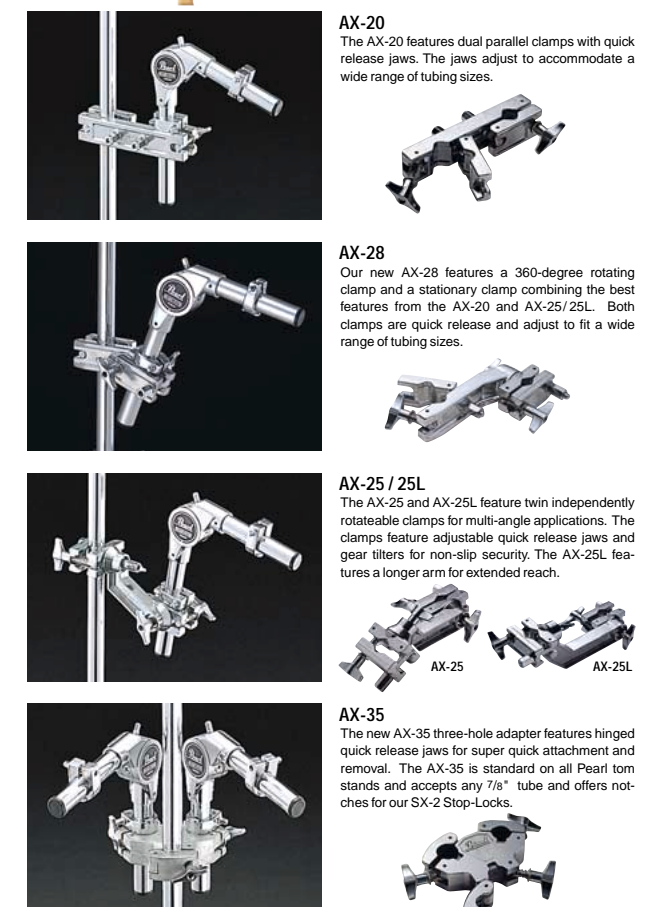

AX-20
The AX-20 features dual parallel clamps with quick release jaws. The jaws adjust to accommodate a wide range of tubing sizes.

AX-28
Our new AX-28 features a 360-degree rotating clamp and a stationary clamp combining the best features from the AX-20 and AX-25/25L. Both clamps are quick release and adjust to fit a wide range of tubing sizes.

AX-25 / 25L
The AX-25 and AX-25L feature twin independently rotatable clamps for multi-angle applications. The clamps feature adjustable quick release jaws and gear tilters for non-slip security. The AX-25L features a longer arm for extended reach.

AX-35
The new AX-35 three-hole adapter features hinged quick release jaws for super quick attachment and removal. The AX-35 is standard on all Pearl tom stands and accepts any 7/8" tube and offers notches for our SX-2 Stop-Locks.

Allen Shellenberger / Lit
Ashwin Sood / Sarah McLaughlin
Chad Sexton / 311
John Otto / Limp Bizkit
Jon Wysocki / Staind
Travis Barker / Blink 182
Virgil Donati / Planet X

Robby Ameen
Igor Cavalera / Sepultura
Dennis Chambers / Niacin
Jimmy DeGrasso / Megadeth
Steve Ferrone / Tom Petty
Omar Hakim / Chic, Madonna
Horacio Hernandez
Will Kennedy
Mike Mangini / Steve Vai
Darrin Mooney / Primal Scream
Jonathan Mover
Ian Paice / Deep Purple
Vinnie Paul / Pantera
Scott Rockenfield / QUEENSRÿCHE
Eric Singer / KISS
Chad Smith / Red Hot Chili Peppers
Marvin "Smitty" Smith / The Tonight Show
Tico Torres / Bon Jovi

On Tour with Pearl Hardware.

Pearl[®]

The best reason to play drums.

Products and specifications are subject to change without notice.
For more information on these or any Pearl product, visit your local authorized Pearl Dealer.
You can also visit us on the World Wide Web Site
www.pearldrums.com